

**TA-UNI 1-pipe (Kvs 1,5)
RVT/RVO**

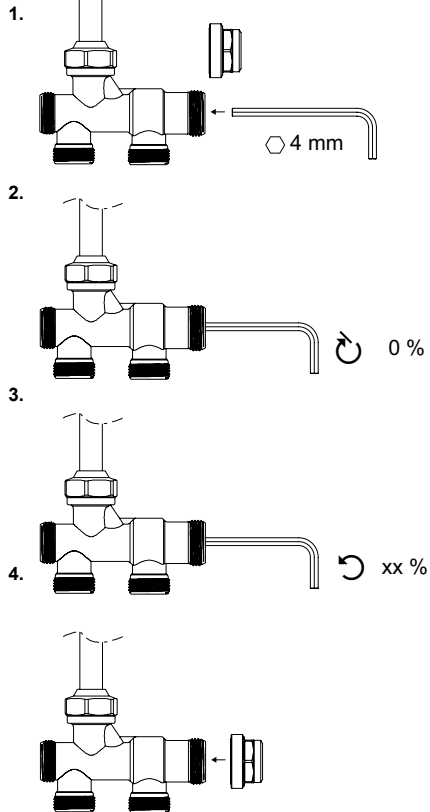

TA-UNI (1-pipe) – RVT						
%	0	10	20	30	40	-
Kv ΔT_{2K}	0,9	1,0	1,1	1,15	1,25	-
No.	**	2	2,75	3,5	*	-
TA-UNI (1-pipe) – RVO						
%	0	10	20	30	40	50
Kv	0,90	1,0	1,1	1,2	1,45	1,5
No.	**	2	2,75	3,25	5,25	*

*) Fullt öppen, Helt åpen, Täysin auki, Fully open
 **) Stängd, Stengt, Suljettu, Closed

**TA-UNI 2-pipe (Kvs 1,0)
Calypso TRV-3**

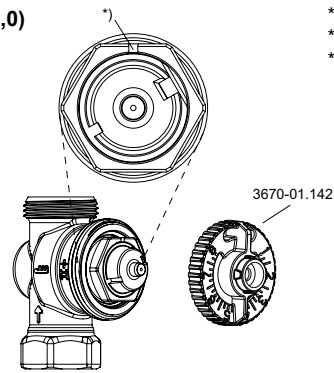

*) Index
 *) Merkki
 *) Indekspunkt

Q [m ³ /h]	100		150		200		250		300		350		400		450		500		550		600		650		700		750		800		850		900		950			
	ΔT [K]	5	10	15	5	10	15	5	10	15	5	10	15	5	10	15	5	10	15	5	10	15	5	10	15	5	10	15	5	10	15	5	10	15				
ΔP [kPa]	5	10	15	5	10	15	5	10	15	5	10	15	5	10	15	5	10	15	5	10	15	5	10	15	5	10	15	5	10	15	5	10	15	5	10	15		
	2,3	3,3	3,5	2,2	3,3	3,4	2,2	2,2	2,2	2,2	2,2	2,2	2,2	2,2	2,2	2,2	2,2	2,2	2,2	2,2	2,2	2,2	2,2	2,2	2,2	2,2	2,2	2,2	2,2	2,2	2,2	2,2	2,2	2,2	2,2	2,2		
	6	6	6	6	6	6	6	6	6	6	6	6	6	6	6	6	6	6	6	6	6	6	6	6	6	6	6	6	6	6	6	6	6	6	6	6		
	7	7	7	7	7	7	7	7	7	7	7	7	7	7	7	7	7	7	7	7	7	7	7	7	7	7	7	7	7	7	7	7	7	7	7	7		
	8	8	8	8	8	8	8	8	8	8	8	8	8	8	8	8	8	8	8	8	8	8	8	8	8	8	8	8	8	8	8	8	8	8	8	8	8	
	7	7	7	7	7	7	7	7	7	7	7	7	7	7	7	7	7	7	7	7	7	7	7	7	7	7	7	7	7	7	7	7	7	7	7	7	7	
	6	6	6	6	6	6	6	6	6	6	6	6	6	6	6	6	6	6	6	6	6	6	6	6	6	6	6	6	6	6	6	6	6	6	6	6	6	
	5	5	5	5	5	5	5	5	5	5	5	5	5	5	5	5	5	5	5	5	5	5	5	5	5	5	5	5	5	5	5	5	5	5	5	5	5	
	4	4	4	4	4	4	4	4	4	4	4	4	4	4	4	4	4	4	4	4	4	4	4	4	4	4	4	4	4	4	4	4	4	4	4	4	4	
	3	3	3	3	3	3	3	3	3	3	3	3	3	3	3	3	3	3	3	3	3	3	3	3	3	3	3	3	3	3	3	3	3	3	3	3	3	3
	2	2	2	2	2	2	2	2	2	2	2	2	2	2	2	2	2	2	2	2	2	2	2	2	2	2	2	2	2	2	2	2	2	2	2	2	2	2
	1	1	1	1	1	1	1	1	1	1	1	1	1	1	1	1	1	1	1	1	1	1	1	1	1	1	1	1	1	1	1	1	1	1	1	1	1	



10 kPa \approx 100 mbar \approx 1 mWS

*We reserve the right to introduce technical alterations
 without previous notice.*

303 445-20
 04.2020



**TA-UNI
 1-pipe/2-pipe**

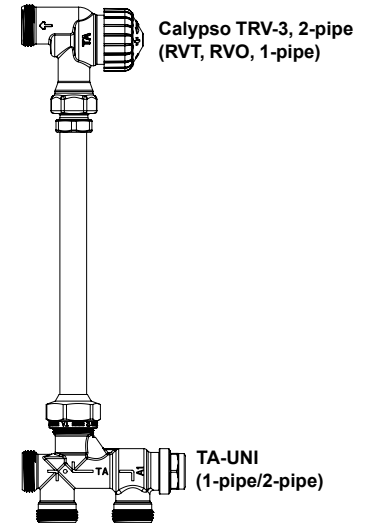
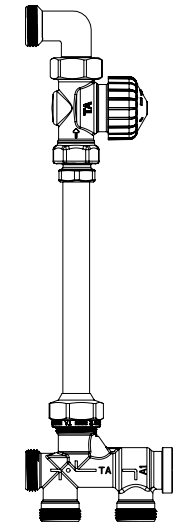

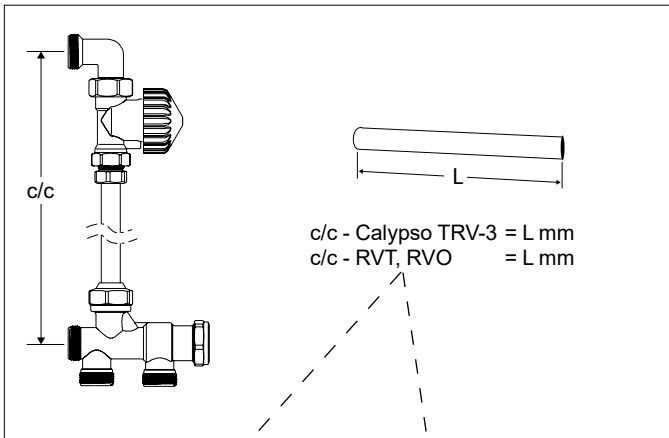
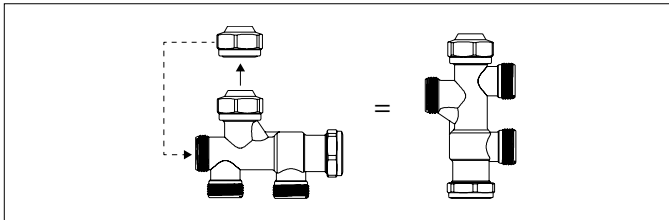
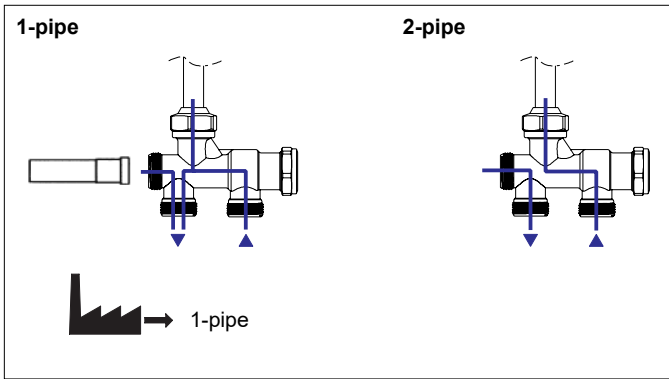

DN 10				
Calypso TRV-3	-80 mm	-43 mm		✓
RVT, RVO	-	-36 mm		-

