

PLANOX ECO

451219.009.19 | Surface-mounted damp-proof luminaires



Ceiling and wall luminaires
4051859431183
L 1700, B 66, H 71

ceiling mounting, pendant, wall (surface)
grey

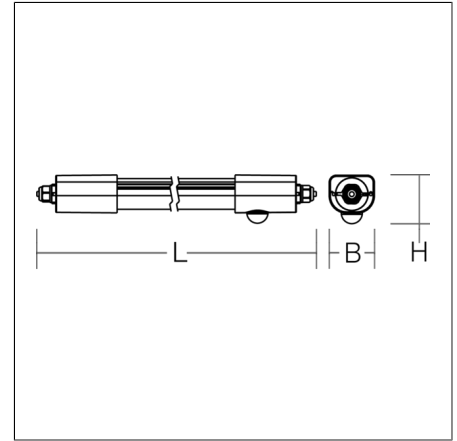

Moisture-proof luminaire with slim, flat housing. Side panels: plastic, grey polycarbonate, shockproof. Diffuser made of plastic (polycarbonate), opal, shockproof. Diffuser is extruded, prismatic inside and UV-resistant. Symmetrical light distribution. Homogeneous light distribution. Indirect light to illuminate the ceiling. Flexible installation thanks to sliding mounting brackets. Ideal for luminaire replacement. Ceiling mounting stainless steel brackets and triangular brackets for pendant mounting included in delivery. With integrated movement sensor. Converter encapsulated, integrated and permanently connected to the diffuser and side panel. Luminaire with integrated 4-phase through-wiring to connect multiple luminaires. Cable screw fittings for convenient wiring. Turn lock fastener on both sides for easy installation. Multi-Lumen: 2 steps adjustable luminous flux. Factory setting is "H" (high lumen). Luminaires with limited surface temperature in accordance with DIN EN 60598-2-24 for use in environments in which a deposit of conductive dust on the luminaire can be expected. Qualified for use in the food and drink industry.

Product specifications

Length L	1700 mm
Width B	66 mm
Height H	71 mm
Weight	1.02 kg
Light source	LED
Colour temperature	4000 K
Rated luminous flux	4700 lm, 6800 lm
System power	33 W, 54 W
System efficiency	126 lm/W 142 lm/W
Glare evaluation UGR (4H 8H)	24,9 26,2
Beam angle	down 177°/111° 180°/111° up 180°/107° 180°/105°
Rated life	50000 h (L80/B10)
Colour rendering index (CRI)	80
Colour tolerance	4
Photobiological safety according to EN 62471	Risk group 0
Driver	Converter
Control	on/off
Voltage	220 - 240 V / 50 Hz, 60 Hz
Luminaires on B10A fuse	8
Luminaires on B16A fuse	13
Luminaires on C10A fuse	13
Luminaires on C16A fuse	22
Inrush current / Inrush current duration	26.1 A / 100 µs
CIE Flux Code / CEN Flux Code	36 65 86 78 100
Type of protection	IP 66
Protection class	II
Filament test	750°C - 30 seconds
Impact resistance	IK08
Ambient temperature	-20 °C ... + 45 °C
Safety marks	D-mark
Test marks	
Conformity mark	CE, EAC, UKCA

PLANOX ECO

451219.009.19 | Surface-mounted damp-proof luminaires



Accessories



982180.000
Mounting brackets made of stainless steel (theft protection) for ceiling and wall mounting.



982179.009
End piece for turn lock fastener.

Spareparts



982429.009
Turn lock fastening.