

# INSTALLATION MANUAL

MONTAGEANLEITUNG  
INSTRUCTIONS DE MONTAGE  
ISTRUZIONI PER IL MONTAGGIO

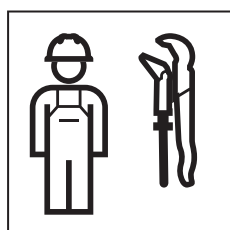

971.483.00.0(00)





### **WARNING**

#### **Augenverletzung und Schnittverletzung durch Glassplitter**

- ▶ Schutzbrille tragen
- ▶ Schnittfeste Handschuhe tragen
- ▶ Glaskanten und -flächen vor Beschädigungen schützen
- ▶ Glasplatte gegen Umfallen sichern
- ▶ Nur unbeschädigte Komponenten verarbeiten
- ▶ Befestigungsrahmen ohne mechanischen Verzug montieren, um Verspannungen der Glasplatte zu verhindern



### **WARNING**

#### **Eye damage and cuts from glass fragments**

- ▶ Wear protective goggles
- ▶ Wear cut-resistant gloves
- ▶ Protect glass edges and surfaces against damage
- ▶ Secure the glass plate against falling
- ▶ Only process components that are not damaged
- ▶ Mount the mounting frame without mechanical distortion to prevent tension on the glass plate



### **AVERTISSEMENT**

#### **Des éclats de verre peuvent atteindre les yeux ou causer des coupures**

- ▶ Porter des lunettes de protection
- ▶ Porter des gants anticoupure
- ▶ Protéger les arêtes et les surfaces en verre contre les dommages
- ▶ Sécuriser la plaque en verre pour l'empêcher de basculer
- ▶ N'installer que des composants non endommagés
- ▶ Monter le cadre de fixation sans distorsion mécanique afin d'éviter tout gauchissement de la plaque en verre



### **AVVERTENZA**

#### **Lesioni agli occhi e da taglio a causa di schegge di vetro**

- ▶ Indossare occhiali di protezione
- ▶ Indossare guanti antitaglio
- ▶ Proteggere dai danni i bordi e le superfici in vetro
- ▶ Fissare adeguatamente la lastra di vetro per evitarne la caduta
- ▶ Lavorare solo componenti integri
- ▶ Montare il telaio di fissaggio senza distorsione meccanica, per evitare deformazioni della lastra di vetro



### **WAARSCHUWING**

#### **Oogletsel en snijwonden door glassplinters**

- ▶ Beschermbril dragen
- ▶ Snijvaste handschoenen dragen
- ▶ Glasranden en glasoppervlakken beschermen tegen beschadiging
- ▶ Glasplaat beveiligen tegen omvallen
- ▶ Alleen onbeschadigde componenten verwerken
- ▶ Montageframe zonder mechanische kromtrekking monteren om spanning in de glasplaat te vermijden



## ADVERTENCIA

### Lesiones en los ojos y por cortes por esquirlas de vidrio

- ▶ Utilizar unas gafas de protección
- ▶ Utilizar unos guantes a prueba de cortes
- ▶ Proteger los bordes y superficies de vidrio frente a daños
- ▶ Asegurar la placa de vidrio frente a caídas
- ▶ Trabajar únicamente componentes libres de daños
- ▶ Montar el marco de fijación sin estiraje mecánico para evitar deformaciones en la placa de vidrio



## AVISO

### Lesão ocular e perigo de corte devido a estilhaços de vidro

- ▶ Utilizar óculos de proteção
- ▶ Utilizar luvas de proteção resistentes
- ▶ Proteger as bordas e as superfícies de vidro contra danos
- ▶ Fixar a placa de vidro contra quedas
- ▶ Processar apenas componentes não danificados
- ▶ Montar o aro de fixação sem estiragem mecânica para evitar tensões na placa de vidro



## ADVARSEL

### Øjenskader og snitsår på grund af glassplinter

- ▶ Brug beskyttelsesbriller
- ▶ Bær skærefaste handsker
- ▶ Beskyt glaskanter og -flader mod skader
- ▶ Sørg for, at glaspladen ikke kan vælte
- ▶ Forarbejd kun intakte komponenter
- ▶ Monter monteringsrammen uden mekanisk forskydning for at undgå opspænding af glaspladen



## ADVARSEL

### Øyeskader og kuttskader på grunn av glasskår

- ▶ Bruk vernebriller
- ▶ Bruk kuttsikre handsker
- ▶ Beskytt glasskanter og -flater mot skader
- ▶ Sikre at glassplaten ikke kan falle
- ▶ Bearbeid kun uskadde komponenter
- ▶ Monter monteringsrammen uten mekanisk forskyvning for å unngå spenninger i glassplaten



## VARNING

### Risk för ögonskador och skärsår på grund av glassplinter

- ▶ Använd skyddsglasögon
- ▶ Använd skärtåliga skyddshandskar
- ▶ Skydda glaskanter och -ytor mot skador
- ▶ Säkra glasplattan mot vältnings
- ▶ Använd endast intakta komponenter
- ▶ Montera monteringsrammen utan mekanisk distorsion för att förhindra förspänningar i glasplattan



## VAROITUS

### Lasinsirujen aiheuttamat silmävammat ja viiltohaavat

- ▶ Käytä suojalaseja
- ▶ Käytä viiltosuojakäsineitä
- ▶ Suojaa lasireunat ja -pinnat vaurioitumiselta
- ▶ Varmista lasilevy kaatumisen varalta
- ▶ Käsittele vain ehjiä osia
- ▶ Estä lasilevyyn kohdistuvat jännitykset asentamalla asennuskehys ilman mekaanista vetoa



## VIÐVÖRUN

### Hætta á augnskaða og skurðum vegna glerbrota

- ▶ Notið hlífðargleraugu
- ▶ Notið skurðarþolna hlífðarhanska
- ▶ Hlífið glerbrúnum og glerflötum við skemmdum
- ▶ Komið í veg fyrir að glerplatan detti
- ▶ Notið eingöngu óskemmda íhluti
- ▶ Setjið festirammann upp án vélrænnar truflunar til að koma í veg fyrir spennu í glerplötunni



## OSTRZEŻENIE

### Obrażenia oczu i obrażenia związane z przecięciem odłamkami szkła

- ▶ Zakładać okulary ochronne
- ▶ Nosić rękawice odporne na przecięcie
- ▶ Chronić krawędzie i powierzchnie szklane przed uszkodzeniem
- ▶ Zabezpieczyć płytę szklaną przed upadkiem
- ▶ Poddawać obróbce wyłącznie nieuszkodzone części
- ▶ Montować ramkę montażową bez mechanicznych zniekształceń, aby zapobiec odkształceniom płyty szklanej



## FIGYELMEZTETÉS

### Üvegszilánk okozta szemsérülés és vágott seb veszélye

- ▶ Viseljen védőszemüveget
- ▶ Viseljen vágásbiztos kesztyűt
- ▶ Óvja az üvegfelületet és az éleket a sérüléstől
- ▶ Biztosítsa az üveglapot eldőlés ellen
- ▶ Csak sértetlen komponenseket munkáljon meg
- ▶ A nyomólapprögztítő keretet mechanikai húzás nélkül szerelje, nehogy feszültség lépjen fel az üveglapban



## VAROVANIE

### Poranenie očí a rezné rany spôsobené úlomkami skla

- ▶ Používajte ochranné okuliare
- ▶ Používajte ochranné rukavice odolné proti porezaniu
- ▶ Sklenené hrany a plochy chráňte pred poškodením
- ▶ Sklenenú platňu zabezpečte proti pádu
- ▶ Na spracovanie používajte iba nepoškodené komponenty
- ▶ Upevňovací rám namontujte bez mechanickej deformácie tvaru, aby nedošlo k vytváraniu nadmerného vnútorného napätia sklenenej platne



## VÝSTRAHA

### Oční a řezná poranění skleněnými střepinami

- ▶ Noste ochranné brýle
- ▶ Noste rukavice odolné proti proříznutí
- ▶ Chraňte hrany a plochy skla před poškozením
- ▶ Zajistěte skleněnou desku proti skácení
- ▶ Zpracovávejte pouze nepoškozené komponenty
- ▶ Upevňovací rámeček namontujte bez mechanické deformace, abyste zamezili prnutí skleněné desky



## OPOZORILO

### Poškodbe oči in ureznine zaradi drobcov stekla

- ▶ Nosite zaščitna očala
- ▶ Nosite rokavice, odporne proti ostrim predmetom
- ▶ Steklene površine in robove zaščitite pred poškodbami
- ▶ Steklenu ploščo zaščitite pred padcem
- ▶ Uporabite samo nepoškodovane komponente
- ▶ Pritrdilni okvir namestite brez mehanskega napenjanja, da ne pride do napetosti v stekleni plošči



## UPOZORENJE

### Ozljede oka i porezotine krhotinama stakla

- ▶ Nosite zaštitne naočale
- ▶ Nosite rukavice otporne na porezotine
- ▶ Staklene rubove i površine zaštitite od oštećenja
- ▶ Staklenu ploču osigurajte od prevrtanja
- ▶ Obradujte samo neoštećene komponente
- ▶ Montažni okvir montirajte bez mehaničkog zatezanja kako bi se spriječilo naprezanje staklene ploče





## UPOZORENJE

**Povrede očiju i posekotine komadićima stakla**

- ▶ Nositi zaštitne naočare
- ▶ Nositi rukavice otporne na rezove
- ▶ Staklene ivice i površine zaštititi od oštećenja
- ▶ Staklenu ploču obezbediti od prevrtanja
- ▶ Obrađivati samo neoštećene komponente
- ▶ Montažni okvir montirati bez mehaničkog odlaganja da bi se sprečila zatezanja staklene ploče



## HOIATUS

**Klaasikildude tõttu silmavigastuste ja sisselõigete oht**

- ▶ Kanda kaitseprille
- ▶ Kanda vastupidavaid kindaid
- ▶ Kaitsta klaasiservi ja -pindu kahjustuste eest
- ▶ Kaitsta klaasplaati ümberkukkumise eest
- ▶ Töötada ainult kahjustamata osadega
- ▶ Monteerida kinnitusraamid ilma mehaanilise viivitusega, et vältida klaasplaadis tekkivaid pingeid



## BRĪDINĀJUMS

**Acu savainojumi un stikla lausku izraisīti griezumī**

- ▶ Nēsājiet aizsargbrilles
- ▶ Nēsājiet izturīgus cimodus
- ▶ Sargiet stikla malas un virsmas no bojājumiem
- ▶ Nodrošiniet stikla loksni pret nokrišanu
- ▶ Apstrādājiet tikai nebojātus komponentus
- ▶ Piemontējiet stiprinājuma rāmi bez mehāniskas stiepes, lai novērstu stikla loksnes nospiegojumu



## ĮSPĖJIMAS

**Akių sužeidimai ir stiklo duženų sukelti įpjovimai**

- ▶ Nešiokite apsauginius akinius
- ▶ Mūvėkite nuo įpjovimų apsaugančias pirštines
- ▶ Užtikrinkite, kad stiklo kraštai ir paviršius nebūtų pažeisti
- ▶ Pasirūpinkite, kad stiklo plokštė nenukristų
- ▶ Naudokite tik nepažeistus komponentus
- ▶ Tvirtinimo rėmą montuokite taip, kad būtų išvengta mechaninės deformacijos ir kad stiklo plokštės neveiktų įtempiai



## ПРЕДУПРЕЖДЕНИЕ

**Нараняване на очите и порязване поради стъклені парченца**

- ▶ Използвайте защитни очила
- ▶ Използвайте защитни ръкавици срещу порязване
- ▶ Пазете стъклените ръбове и повърхности от повреждане
- ▶ Подсигурете стъклената плоча против преобръщане
- ▶ Обработвайте само неповредени компоненти
- ▶ Монтирайте затегателните рамки без механично изкривяване, за да предотвратите деформация на стъклената плоча



## AVERTIZARE

**Leziuni la nivelul ochilor și plăgi prin tăiere din cauza cioburilor de sticlă**

- ▶ Utilizați ochelari de protecție
- ▶ Purtați mănuși de protecție cu rezistență la tăiere
- ▶ Protejați muchiile și suprafețele din sticlă împotriva deteriorării
- ▶ Asigurați placa de sticlă împotriva căderii
- ▶ Prelucrați numai componente care nu prezintă deteriorări
- ▶ Instalați rama de montare fără tensionare mecanică pentru a evita apariția unor tensionări la placa de sticlă



## ΠΡΟΕΙΔΟΠΟΙΗΣΗ

Τραυματισμός οφθαλμών και τραυματισμός κοπής από θραύσματα γυαλιού

- ▶ Φοράτε προστατευτικά γυαλιά
- ▶ Φοράτε γάντια προστασίας από κοπή
- ▶ Προστατεύετε τις γυάλινες ακμές και επιφάνειες από ζημιές
- ▶ Ασφαλιζετε την υαλόπλακα από πτώση
- ▶ Επεξεργάζεστε μόνο άθικτα στοιχεία
- ▶ Τοποθετείτε το πλαίσιο στήριξης χωρίς μηχανικές παραμορφώσεις, ώστε να αποτρέπεται η άσκηση τάσεων στην υαλόπλακα



## UYARI

Cam parçalanmalarından kaynaklanan göz ve kesik yaralanmaları

- ▶ Koruyucu gözlük kullanın
- ▶ Kesiğe karşı koruyucu eldiven kullanın
- ▶ Cam kenarlarını ve yüzeyini darbelere karşı koruyun
- ▶ Cam plakayı düşmeye karşı koruyun
- ▶ Sadece zarar görmemiş elemanları kullanın
- ▶ Cam plaka geriliminden korunmak için montaj çerçevesini monte ederken mekanik bozulmadan kaçının



## ΠΡΕΔΥΠΡΕΨΗ

Πовреждение глаз и порезы осколками стекла

- ▶ Использовать защитные очки
- ▶ Использовать прочные на разрез перчатки
- ▶ Защитить кромки и поверхности стекла от повреждений
- ▶ Зафиксировать стеклянную пластину от опрокидывания
- ▶ Работать только с неповрежденными компонентами
- ▶ Монтажную рамку устанавливать без механического перекоса для предотвращения деформации стеклянной пластинки



## ΠΟΠΕΡΕΔΨΗ

Травми очей і порізи уламками скла

- ▶ Носіть захисні окуляри
- ▶ Носіть стійкі до порізів рукавички
- ▶ Захистіть краї та поверхні скла від пошкоджень
- ▶ Зафіксуйте скляну панель від падіння
- ▶ Обробляйте лише непошкоджені компоненти
- ▶ Установіть монтажну рамку без механічних деформацій, щоб запобігти напрузі скляної панелі



## 警告

玻璃碎片会伤害眼睛和引起割伤

- ▶ 戴上防护眼镜
- ▶ 穿戴耐切割的手套
- ▶ 防止玻璃边缘和表面受到损伤
- ▶ 采取措施防止玻璃板翻倒
- ▶ 仅处理未受损的部件
- ▶ 安装固定框架时不可产生机械变形，以避免玻璃板承受张力作用



## تحذير

إصابة العينين ووقوع جروح قطعية جراء شظايا الزجاج

- ◀ احرص على ارتداء نظارة حماية العينين
- ◀ احرص على ارتداء قفازات مؤمنة ضد القطع
- ◀ احرص على حماية الحواف والأسطح الزجاجية من التعرض لأضرار
- ◀ احرص على تأمين اللوح الزجاجي من السقوط
- ◀ لا تتعامل إلا مع المكونات السليمة
- ◀ ركب أطر التثبيت بدون ترحيل ميكانيكي منعا لتعرض اللوح الزجاجي لشدة وتوترات

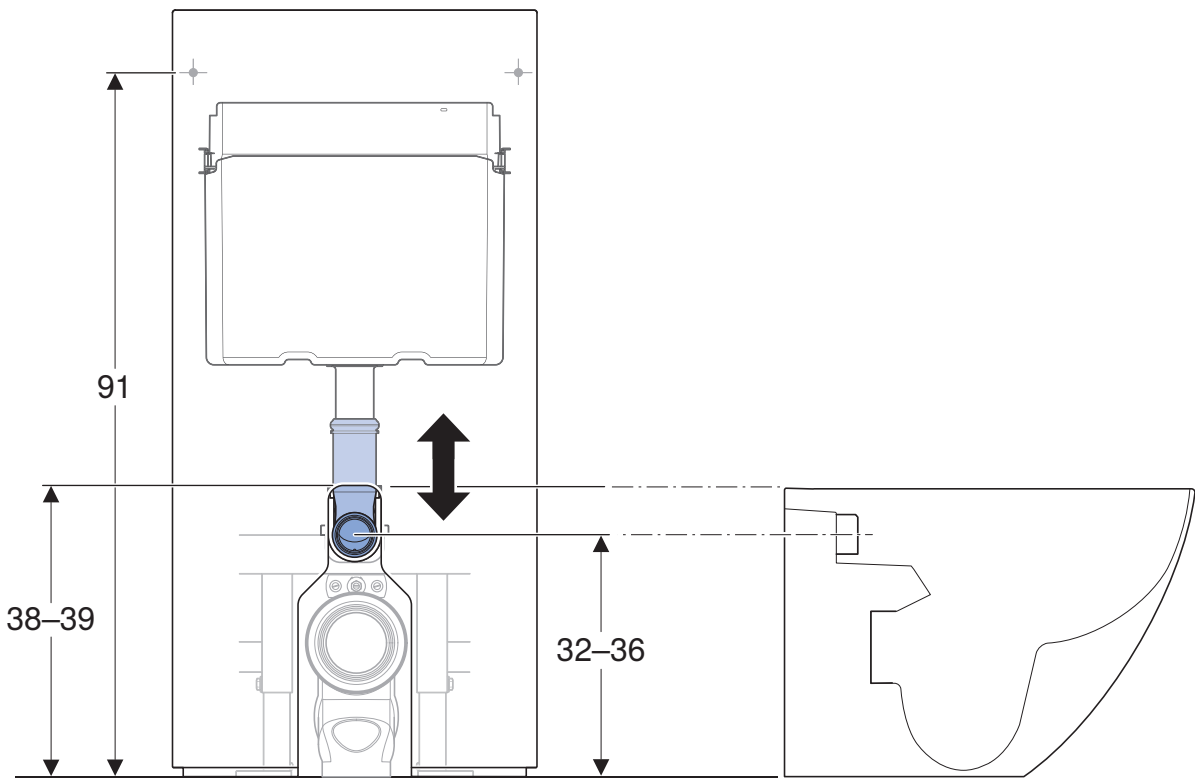
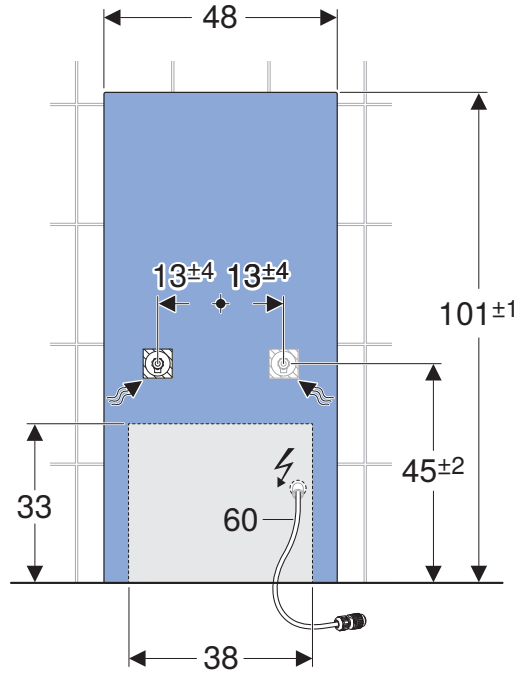
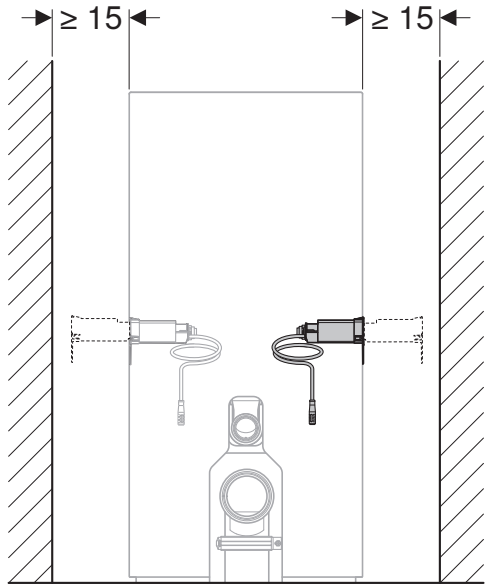

# 1

1

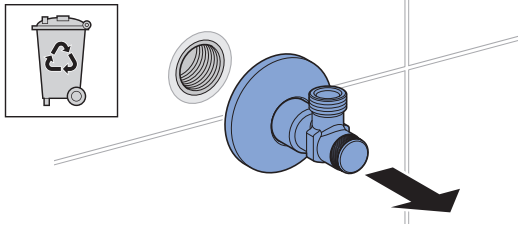

**i**

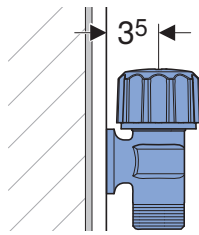

2

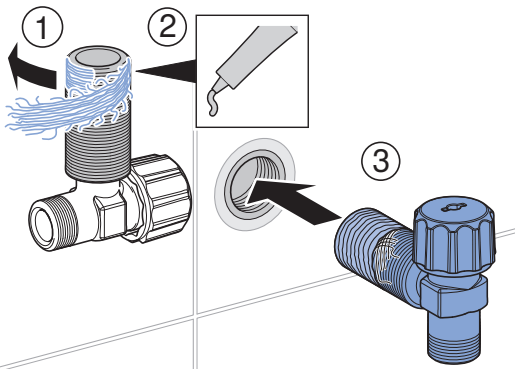

3

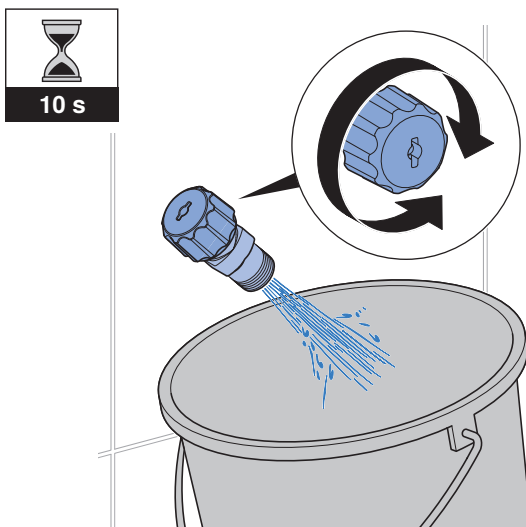

# 2

1

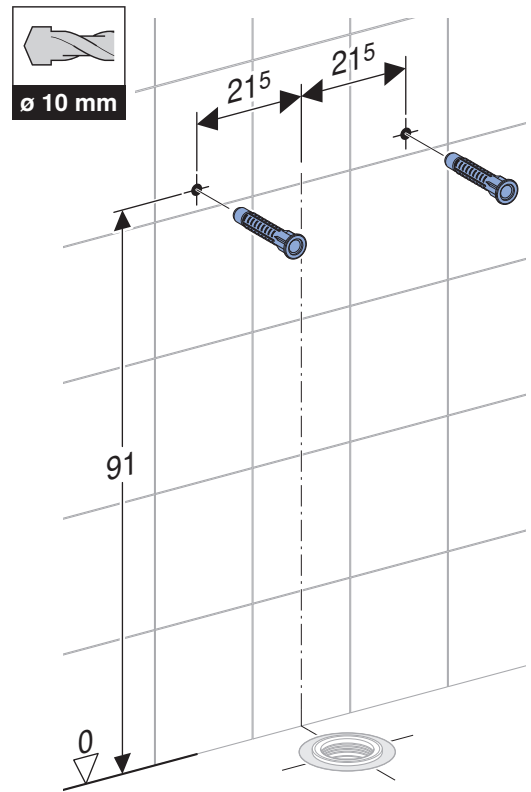

2

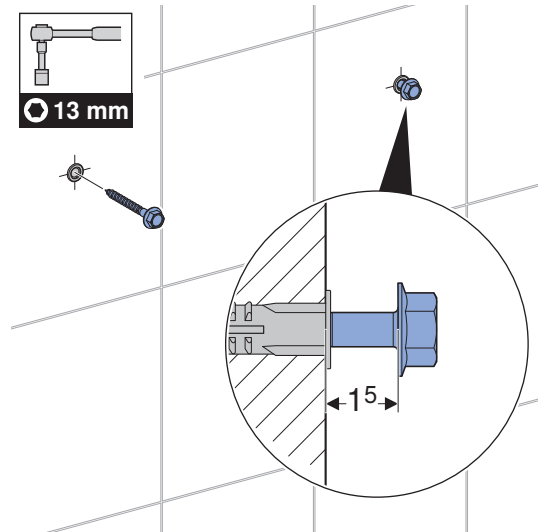

3

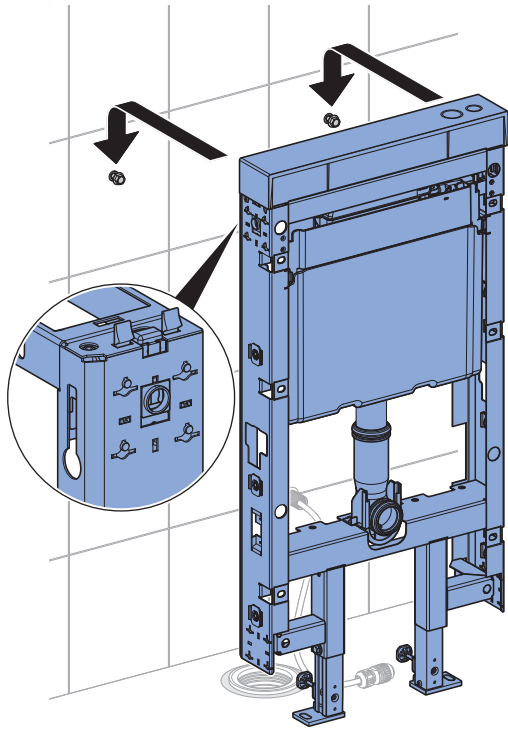

4

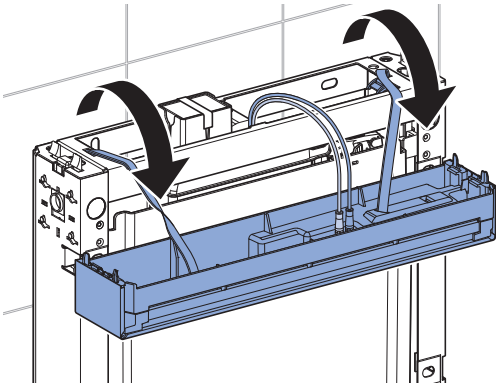

5

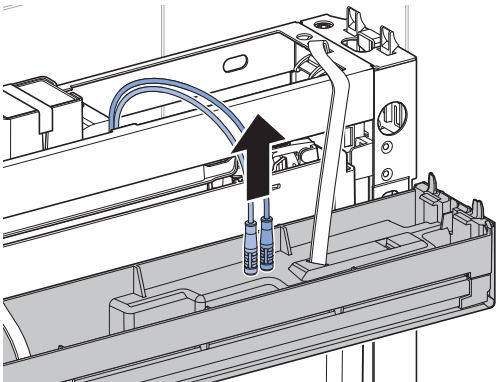

6

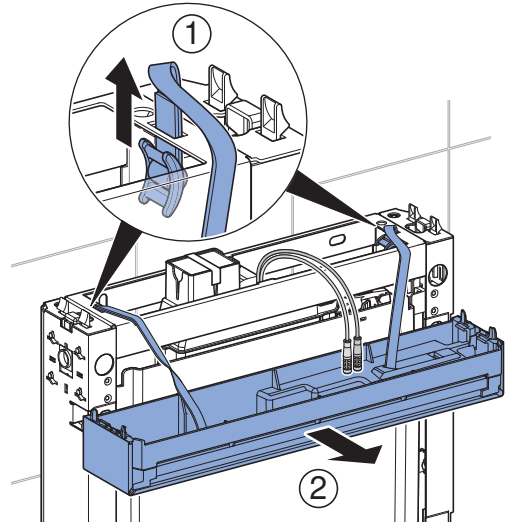

7

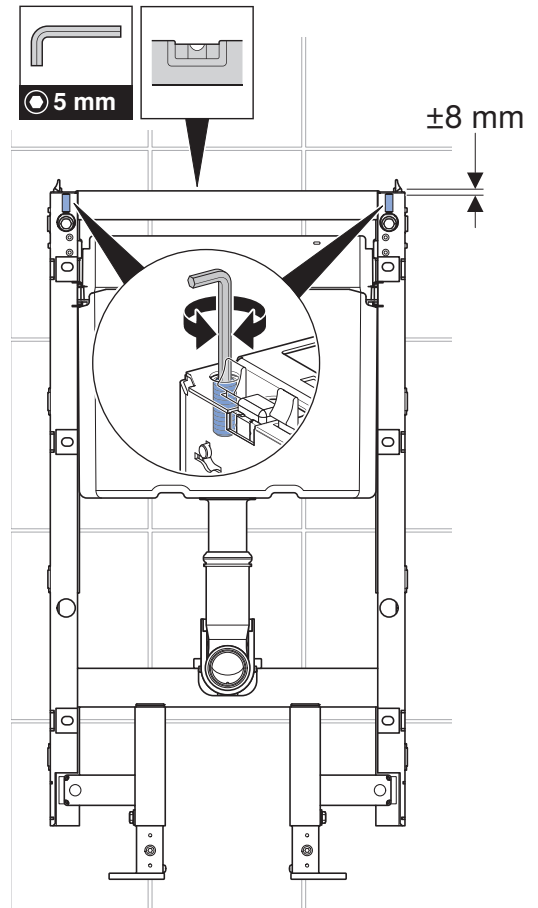

8

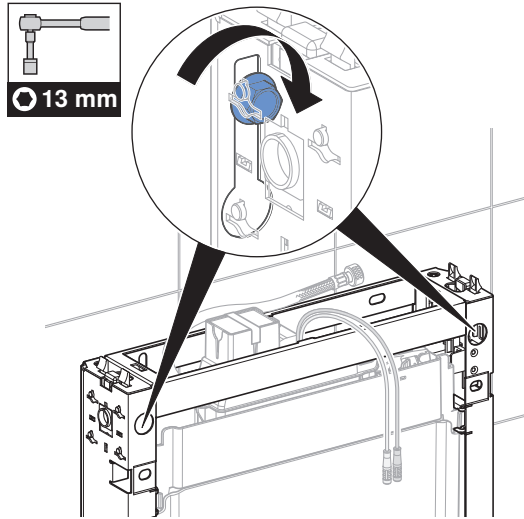

9

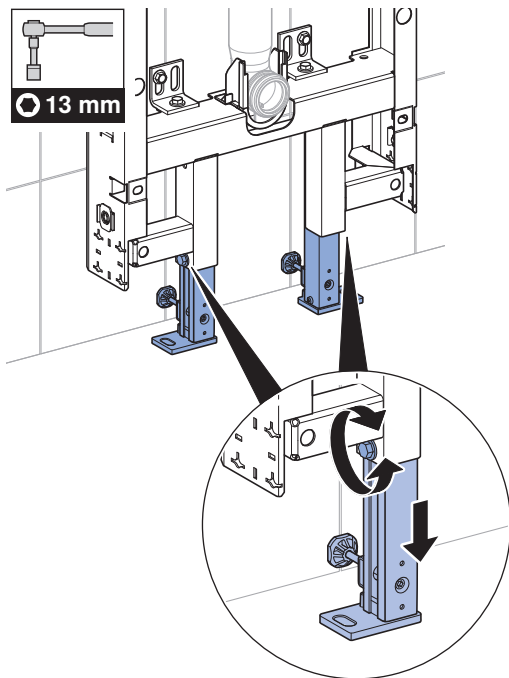

10

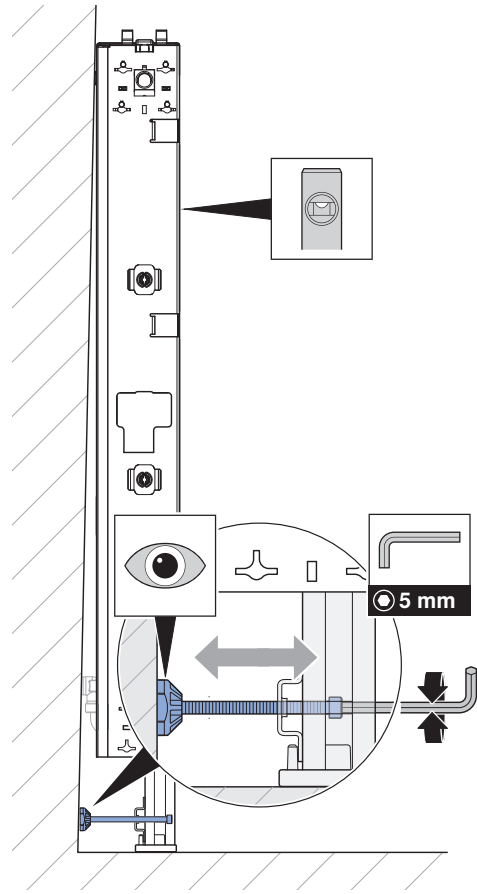

i

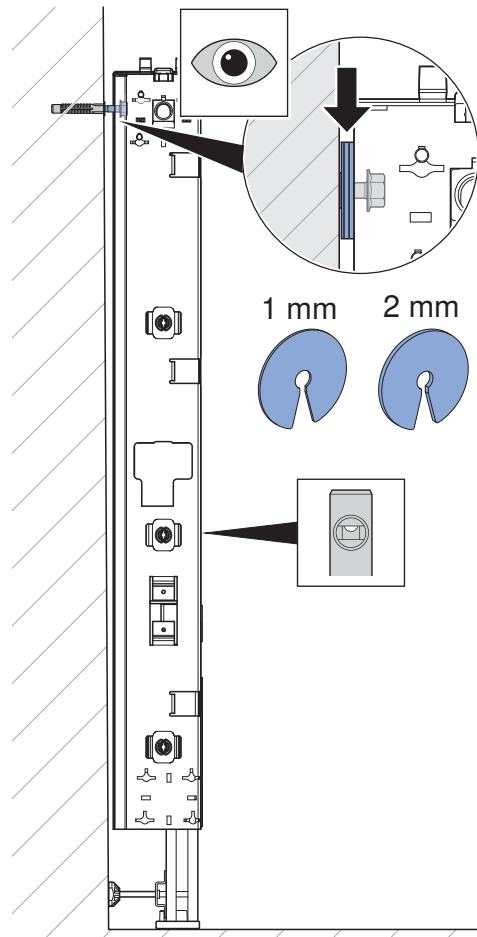

# 3

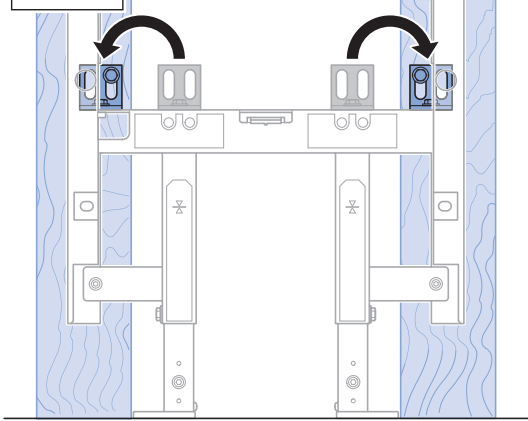
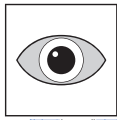

## 1

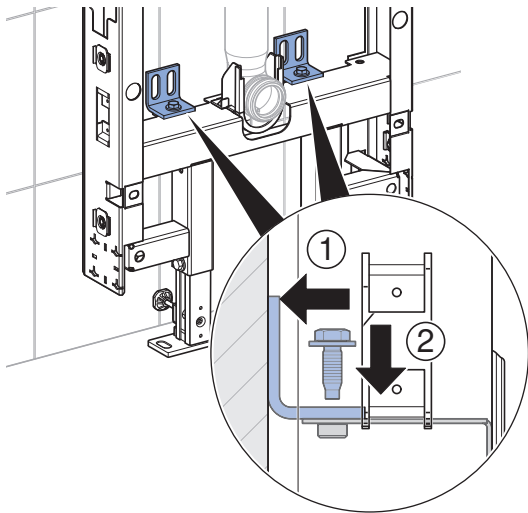

## 2

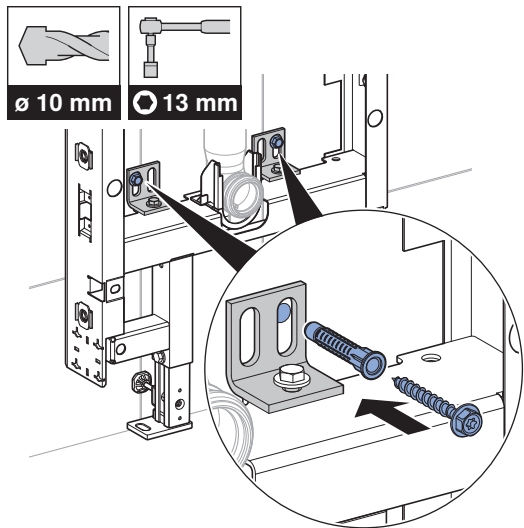

## 3

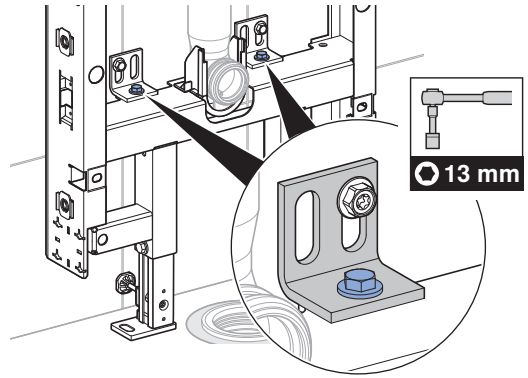

# 4

## 1

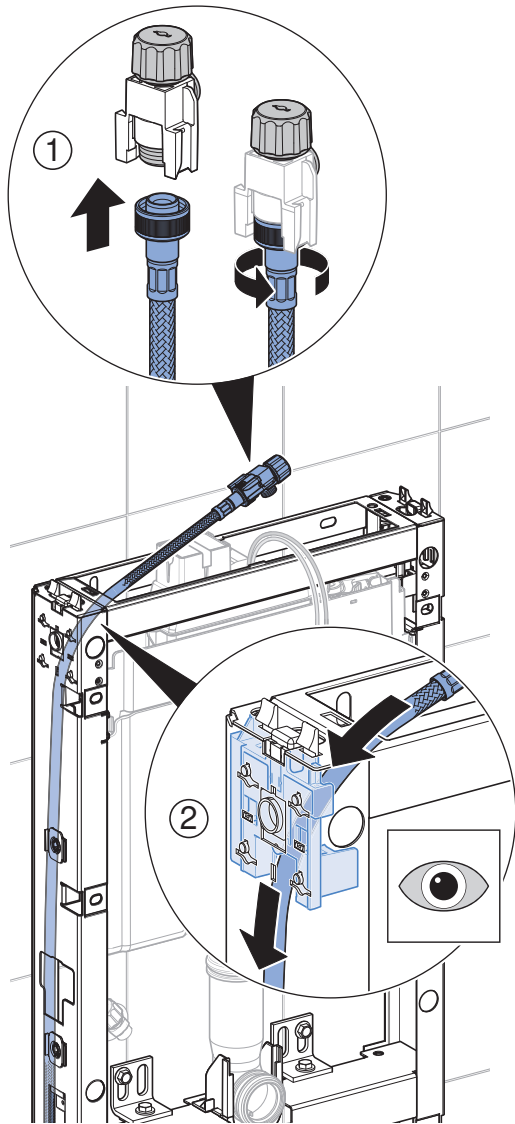

## 2

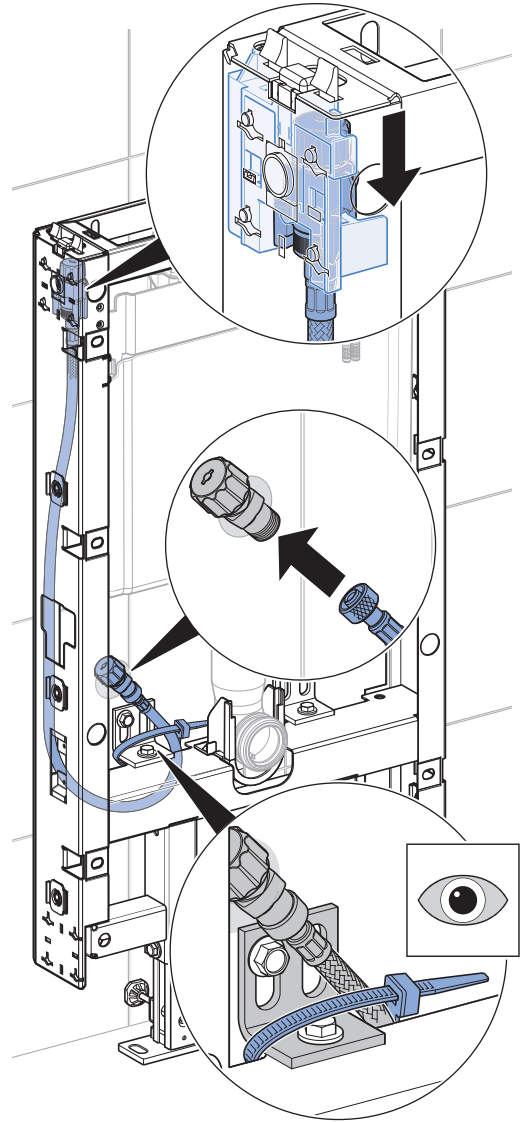

## 3

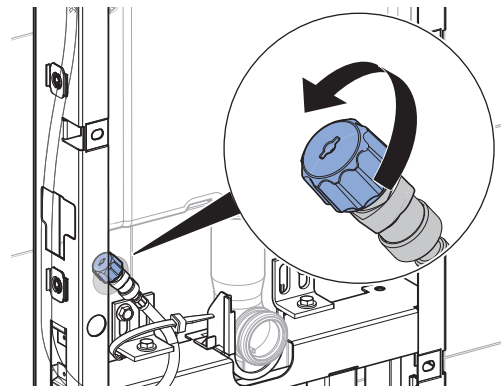



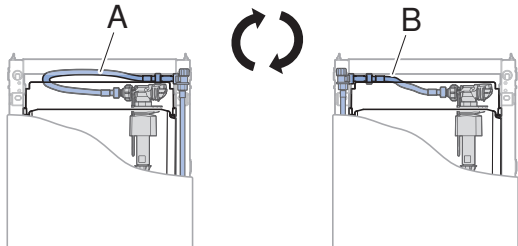
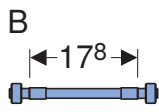
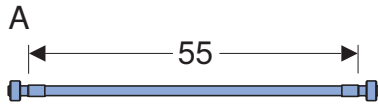

4

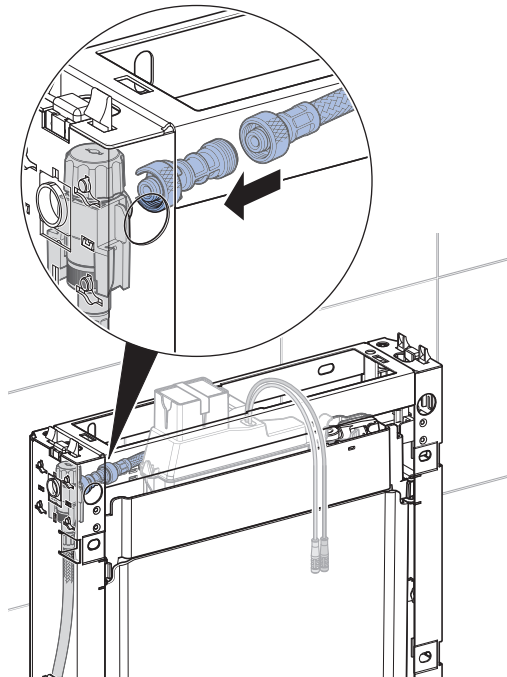

# 5

1

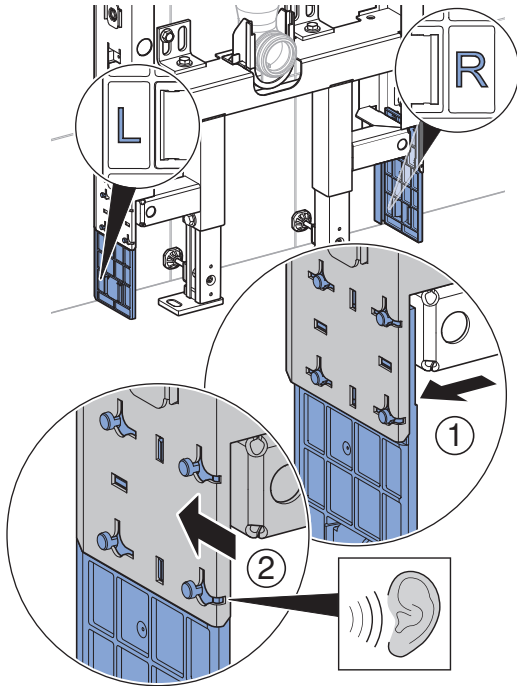

2

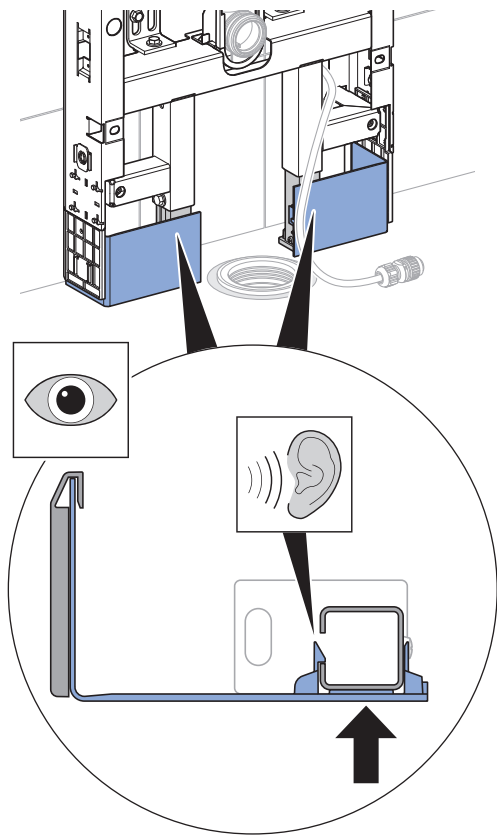

**i**

Monolith Plus

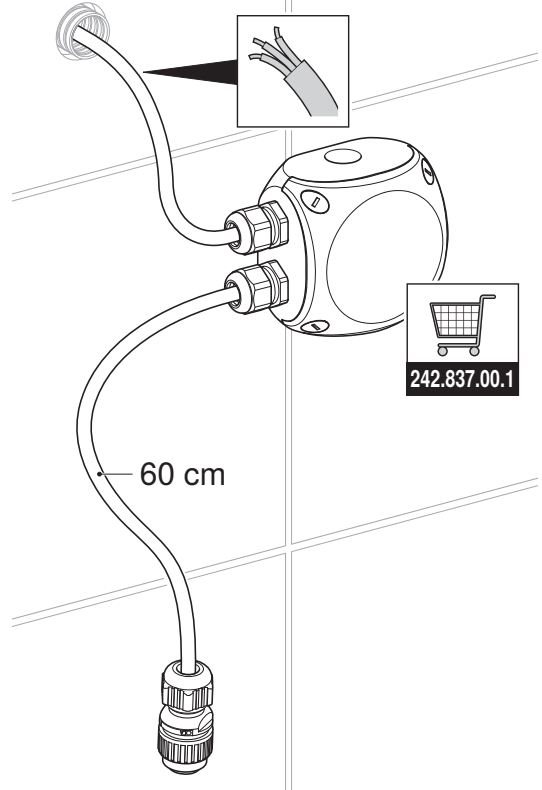

Installation Manual

# 6

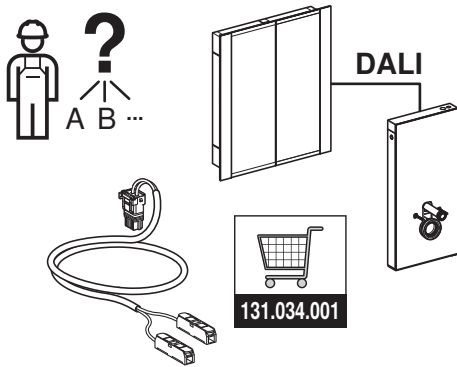
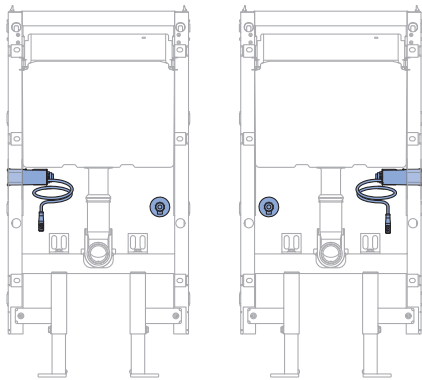

## 1

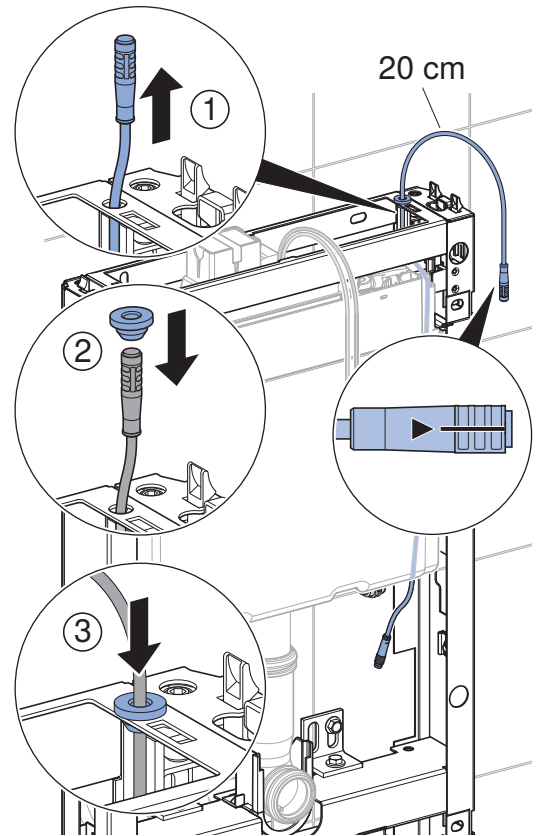

## 2

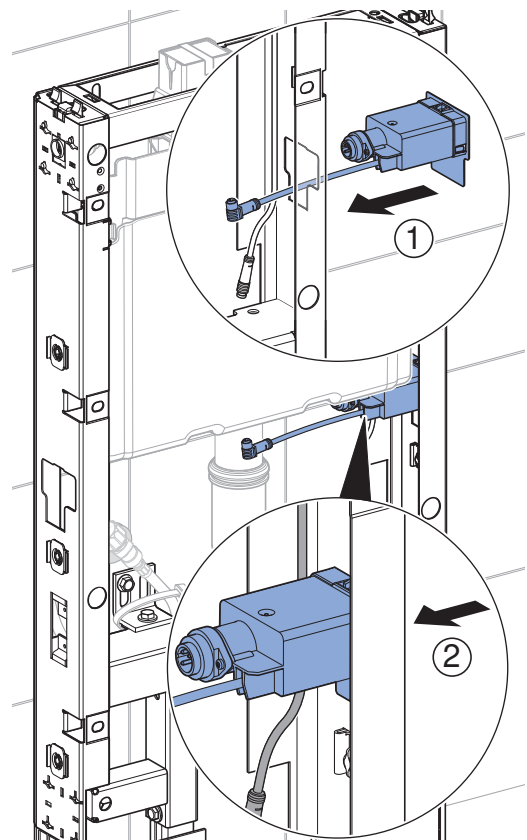

**i**

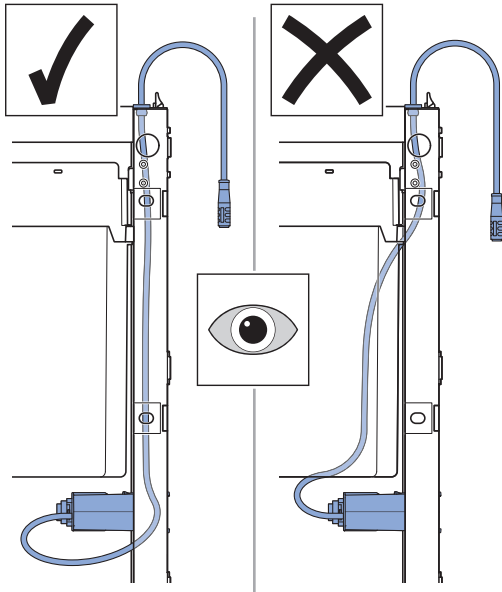

**5**

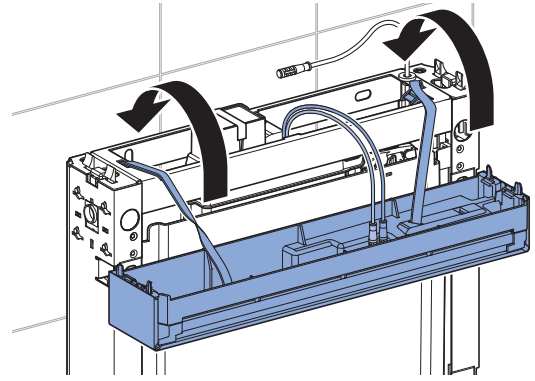

**6**

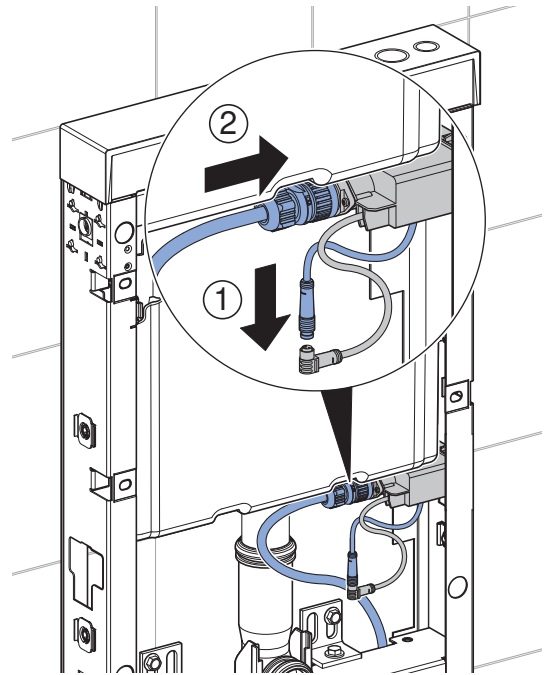

**3**

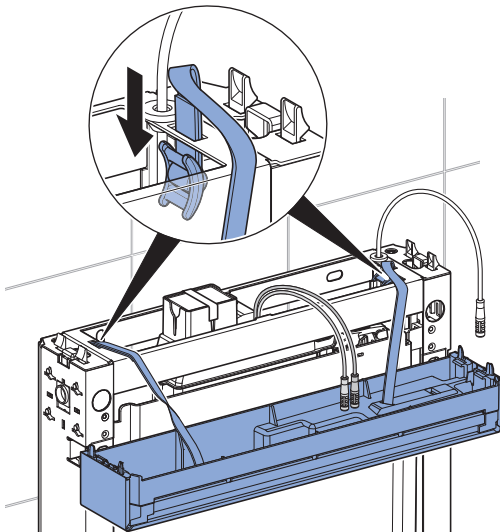

**4**

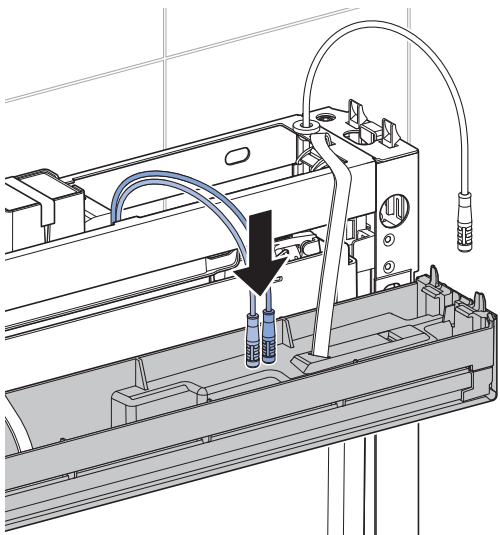

# 7

1

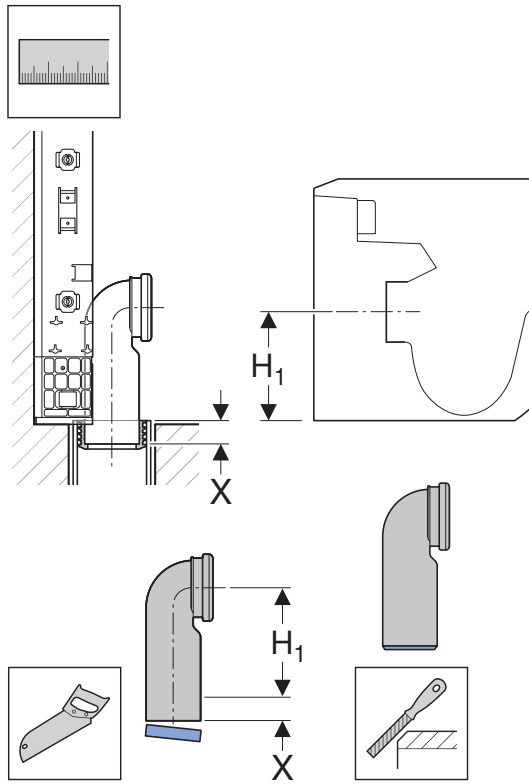

2

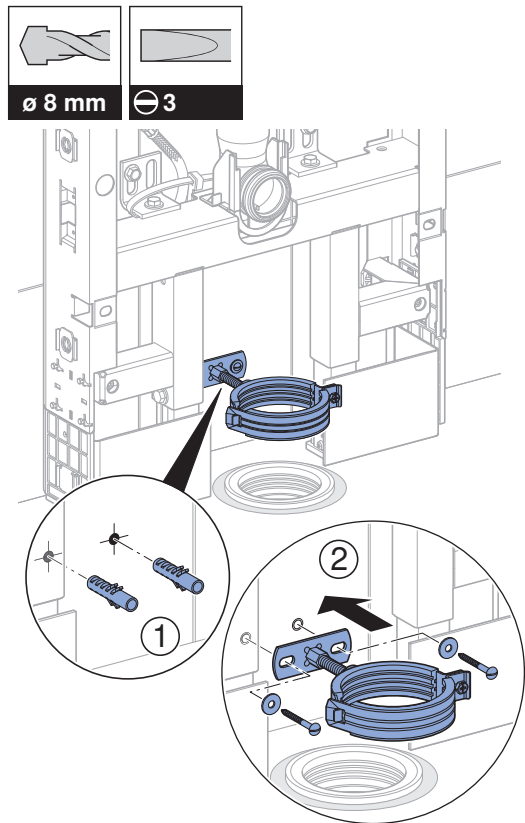

3

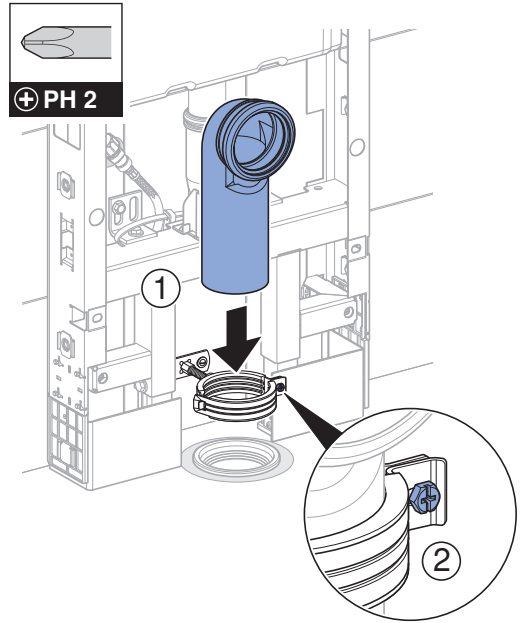

i

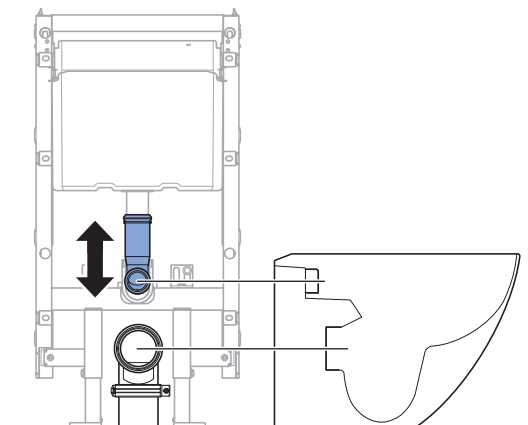

# 8

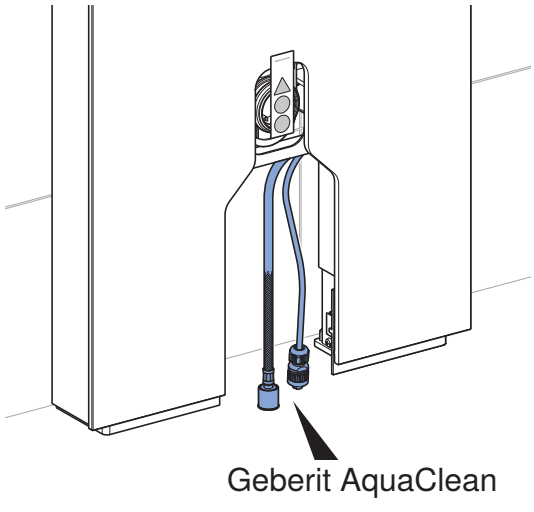

✓



# 1

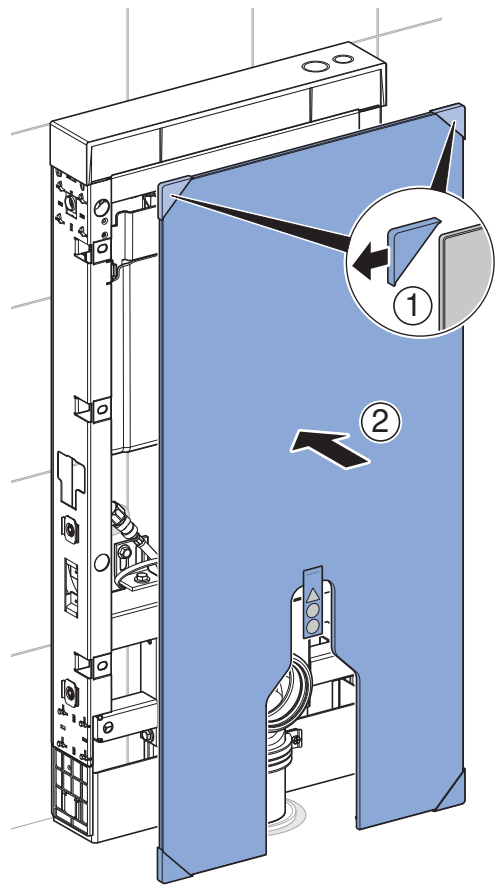

# 2

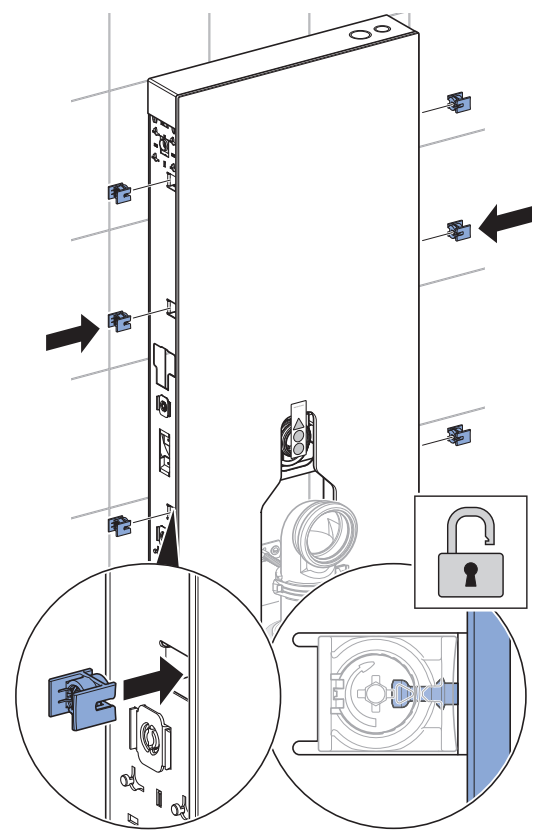

3

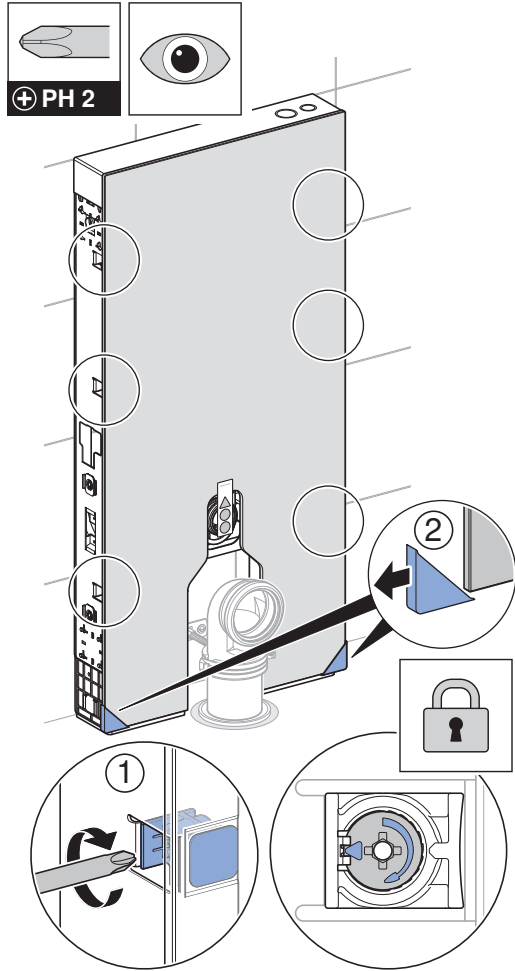

4

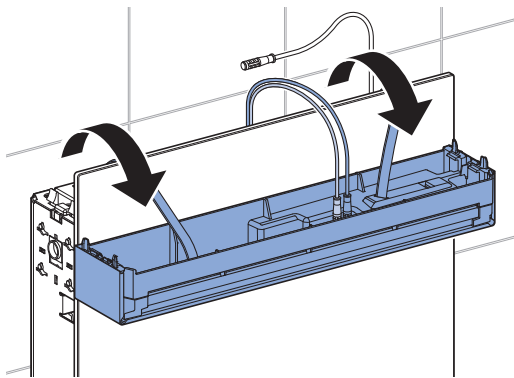

5

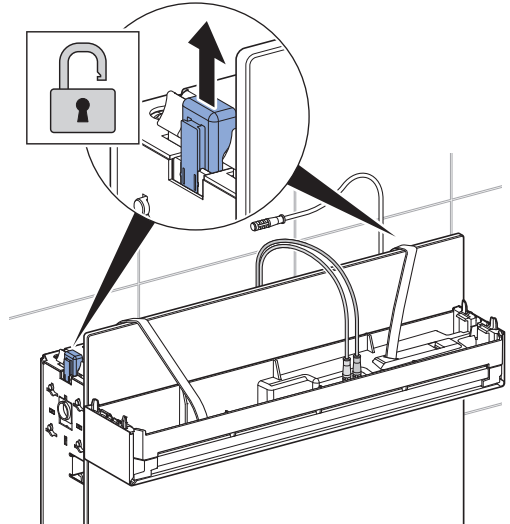

6

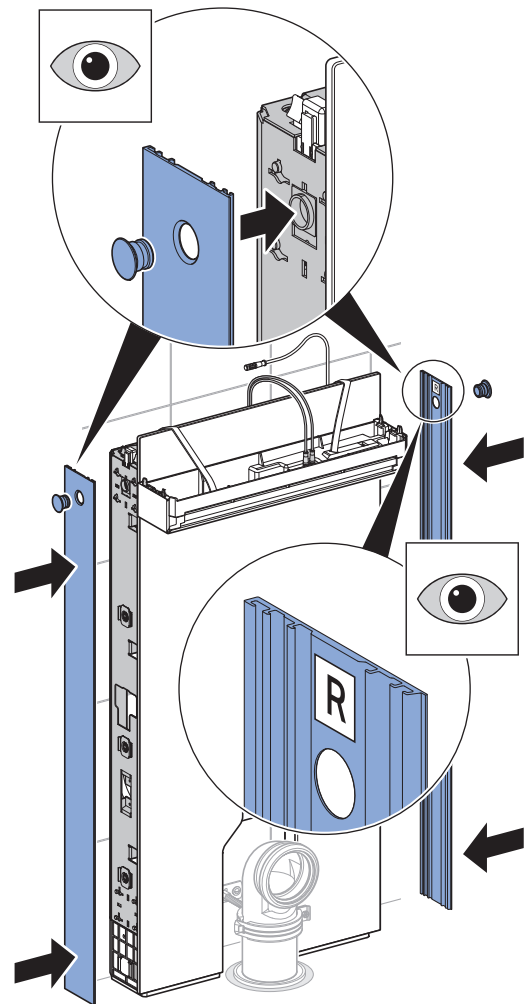

7

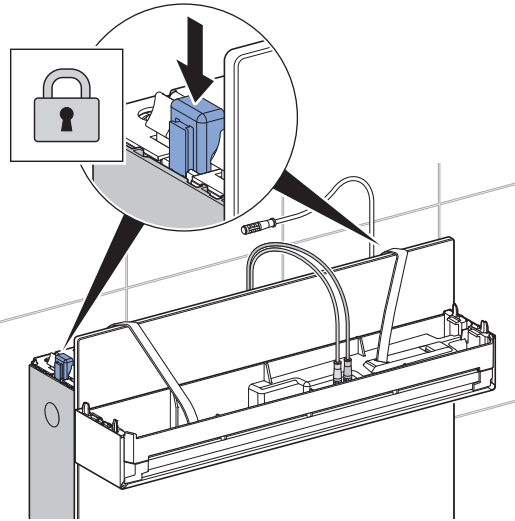

8

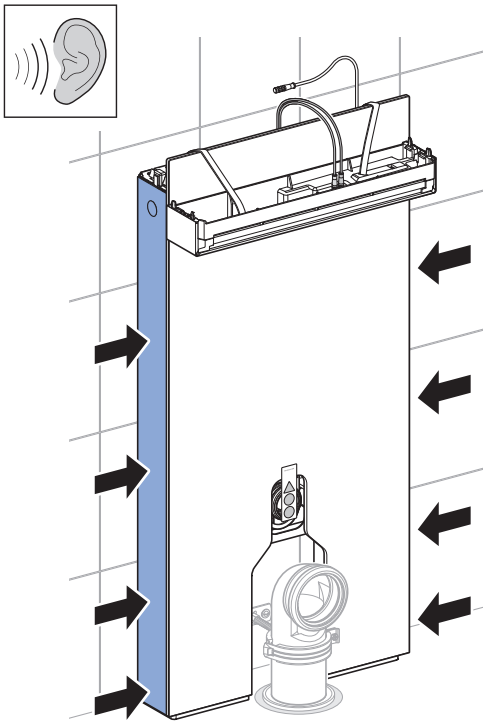

9

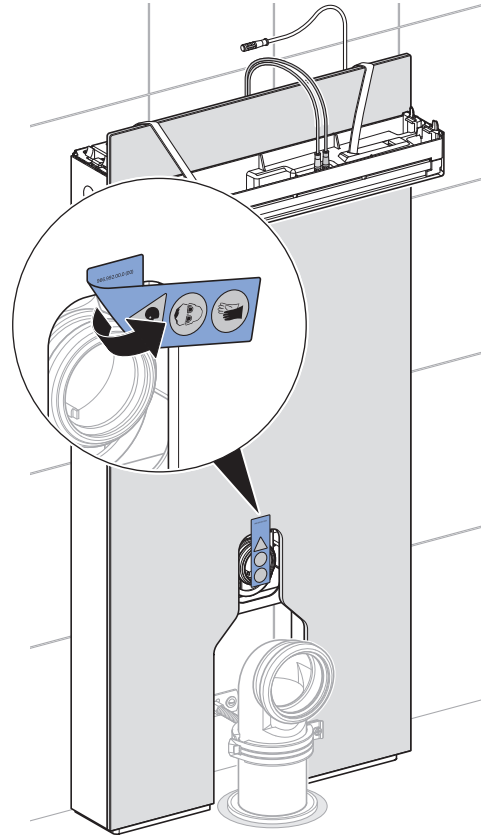



# 9

1

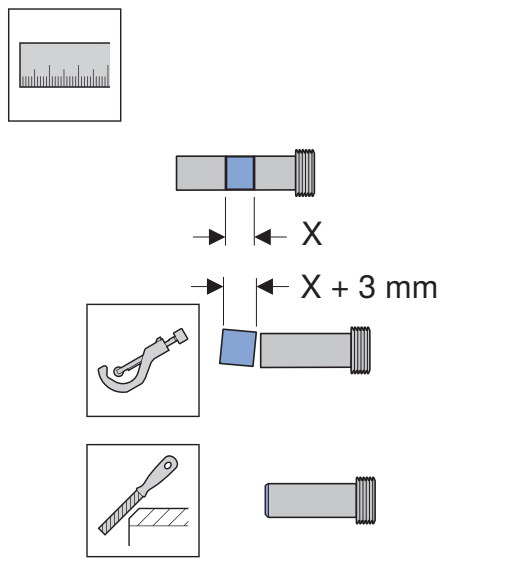
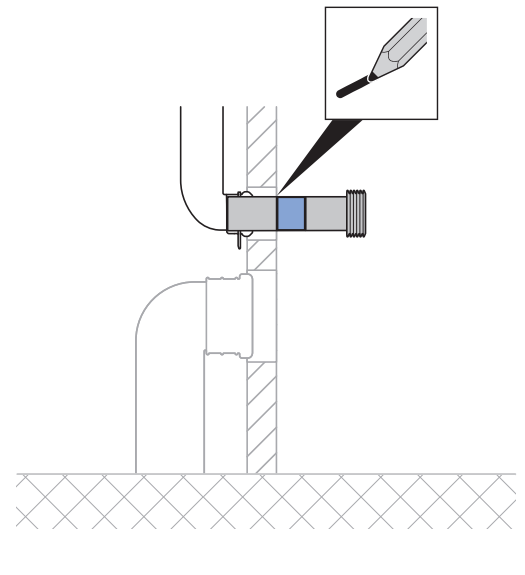
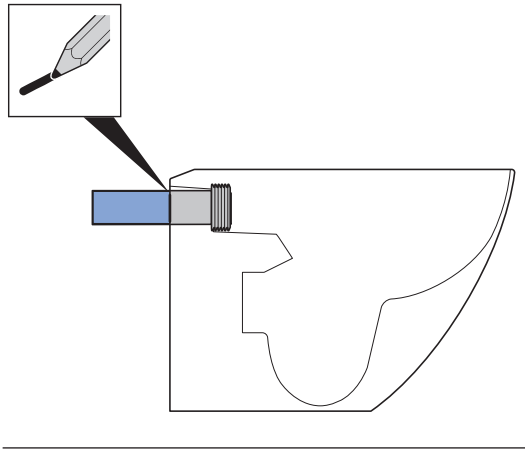

2

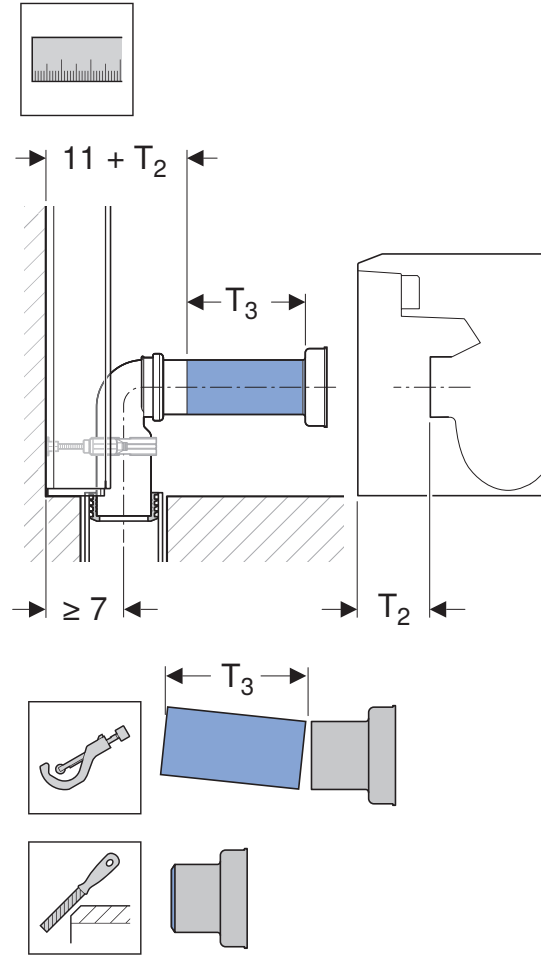

3

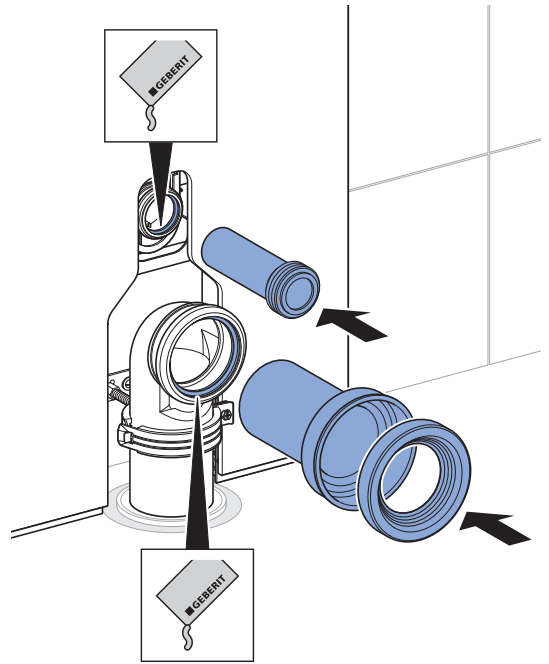

4

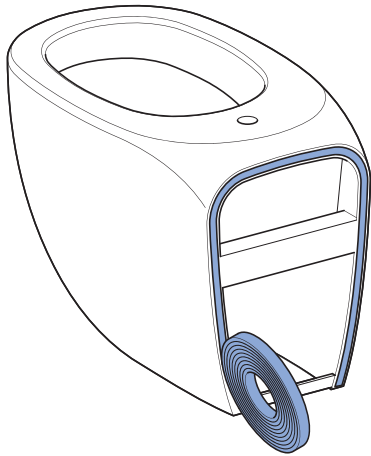

7

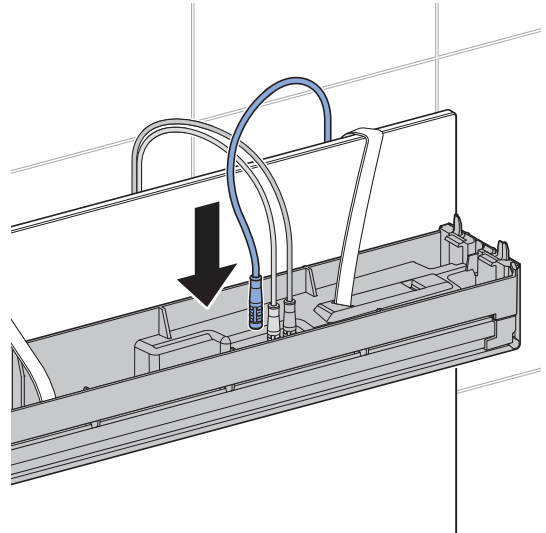

5

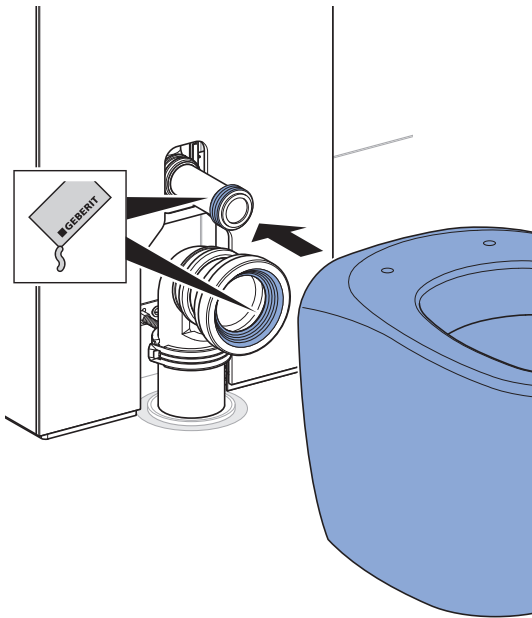

8

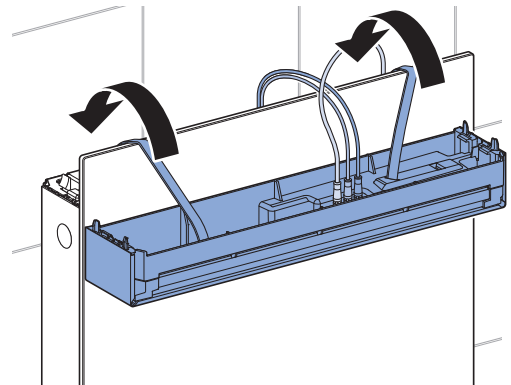

6

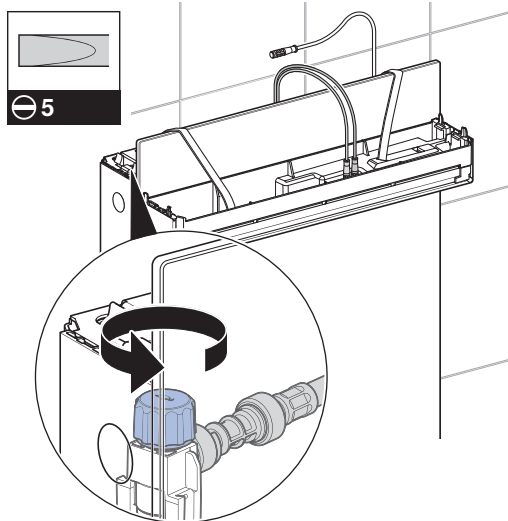

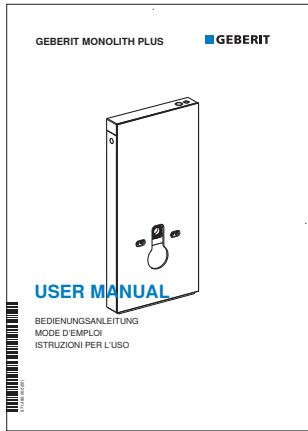



---

Geberit International AG  
Schachenstrasse 77, CH-8645 Jona  
documentation@geberit.com  
www.geberit.com