

Electronic switch insert

User Guide

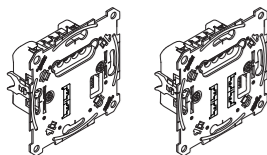

Electronic switch insert

Art. no. MEG5151-0000

Electronic switch insert, 2-gang

Art. no. MEG5152-0000

Necessary accessories

- To be completed with:
- Corresponding inserts (see function overview)

Accessories

- PlusLink Expander (Art. no. MEG5130-0001)
- PlusLink distributor (3 cycles) (Art. no. MEG5130-0001)

For your safety

DANGER
HAZARD OF ELECTRIC SHOCK, EXPLOSION, OR ARC FLASH.

Safe electrical installation must be carried out only by skilled professionals. Skilled professionals must prove profound knowledge in the following areas:

- Connecting to installation networks
- Connecting several electrical devices
- Laying electric cables
- Safety standards, local wiring rules and regulations

Failure to follow these instructions will result in death or serious injury.

DANGER
Risk of death from electric shock.

The outputs may carry an electrical current even when the device is switched off. Always disconnect the fuse in the incoming circuit from the supply before working on connected loads.

DANGER
Risk of death from electric shock.



The PlusLink carries an electrical current even when the device is switched off. Before working on the device, always disconnect it from the supply by means of the fuse in the incoming circuit. If one or more PlusLink lines are separately fused in your installation then they are not electrically isolated from one another. In this case, you should use the PlusLink Expander.

CAUTION
The device can become damaged.

The voltage difference between different phases can damage the device. Connect all connected devices of one or several PlusLink lines to the same phase or use a PlusLink terminal for cross-phase installation.

Getting to know the electronic switch insert

You can use the electronic switch insert (referred to below as the **insert**) to switch ohmic or inductive loads per channel:

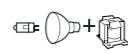
-  Incandescent lamps (ohmic load)
-  230 V halogen lamps (ohmic load)
-  Low-voltage halogen lamps with dimmable wound transformer (inductive load)

The insert is overload-proof and short-circuit-proof.

The insert also comes with one (1-gang insert) or two (2-gang insert) **PlusLink** inserts, with which you can control the channels from another location. The insert, completed with a module (see the function overview), is the receiving device and is controlled via **PlusLink (PL)** by the transmitting device.

Transmitting devices are, for instance:

- Central unit inserts (completed with relevant modules)
- Side controller Plus, 1-gang/2-gang
- Mechanical push-buttons
- External sensors

To be able to use the PlusLink, you require a separate core in your installation.

i The total length of cable sections in a PL line is not allowed to exceed 100 m (when a 3-core cable is used).

CAUTION
The insert can become damaged.

- Always operate the insert in compliance with the specified technical data.
- Operate the insert only on a sinusoidal mains voltage.
- Switching socket-outlets is prohibited. The risk of overloading and the risk of unsuitable loads being connected is too high.
- If a terminal is used for looping, the insert must be protected with a 6 A circuit breaker.

Function overview of the 1-gang insert completed with corresponding modules

Module:	Function:
Push-button module Basic, 1-gang	• switching on/off
Push-button module Basic, 2-gang	• switching on/off • Calling up and saving lightscenes
Push-button module Comfort, 1-gang	• switching on/off • Staircase lighting function
Push-button module Comfort, 2-gang	• switching on/off • Calling up and saving lightscenes • Staircase lighting function
Connected push-button module, 1-gang	• Switching on/off • Additional app functions ¹
Connected push-button module, 2-gang	• Switching on/off • Calling up and saving lightscenes • Additional app functions ¹
ARGUS 180 flush-mounted sensor module	• Brightness dependent staircase lighting function
ARGUS 180 flush-mounted sensor module with switch	• Brightness dependent staircase lighting function • Permanently switching staircase lighting on/off
Display timer module	• Switching on/off manually • Time-controlled switching on/off • Evaluating DCF timer

¹ For more information about the app and the app functions, please read the instructions for the corresponding module.

Function overview of the 2-gang insert complete with corresponding modules

Module:	Function:
Push-button module Basic, 1-gang	• Switching both channels on/off together
Push-button module Basic, 2-gang	• Switching both channels on/off separately
Push-button module Comfort, 1-gang	• Switching both channels on/off together • Staircase lighting function
Push-button module Comfort, 2-gang	• Switching both channels on/off separately • Staircase lighting function (both channels together)
Connected push-button module, 1-gang	• Switching both channels on/off together • Additional app functions ¹
Connected push-button module, 2-gang	• Switching both channels on/off separately • Additional app functions ¹
ARGUS 180 flush-mounted sensor module	• Brightness dependent staircase lighting function • Brightness independent staircase lighting function
ARGUS 180 flush-mounted sensor module with switch	• Brightness dependent staircase lighting function • Brightness independent staircase lighting function • Permanently switching staircase lighting on/off
Display timer module	• Manually switching on/off both channels at the same time • Time-controlled switching on/off of both channels separately or together • Evaluating DCF timer

¹ For more information about the app and the app functions, please read the instructions for the corresponding module.

Installing the insert

i If you do not install the device in a single, standard flush mounting box, the maximum permissible load is reduced due to the restricted heat dissipation:

Load reduced by	when installed
25 %	in hollow walls *
30 %	Several installed together in combination *
50 %	in 1-gang or 2-gang surface-mounted housing in 3-gang surface-mounted housing

* If several factors apply, add the load reductions together.

Wiring the insert (1-gang) for the application required

Insert as stand-alone device

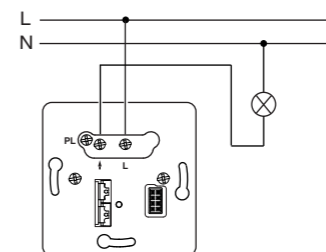

Two inserts connected in parallel

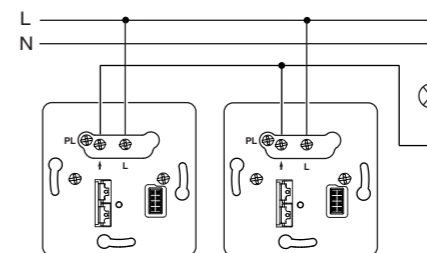

Insert with mechanical push-button via PlusLink

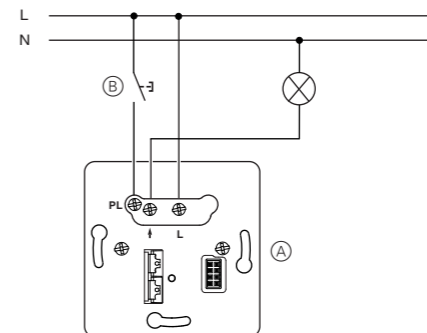

- (A) Electronic switch insert
- (B) Mechanical push-button (toggle mode)

Insert in combination with transmitting device via PlusLink (here shown with side controller Plus)

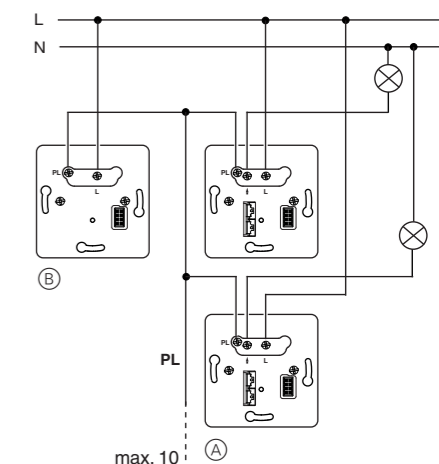

- (A) Electronic switch insert
- (B) Side controller Plus, 1-gang/2-gang (transmitting device)

Wiring the insert (2-gang) for the application required

i If you connect loads on only one channel on a 2-gang insert, then it must be channel 1.

Insert as stand-alone device

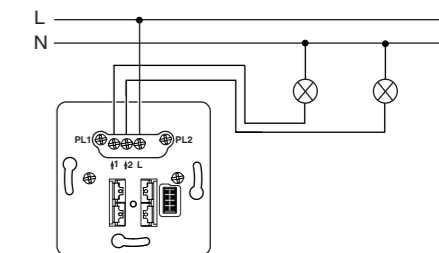

Insert with mechanical push-buttons via PlusLink

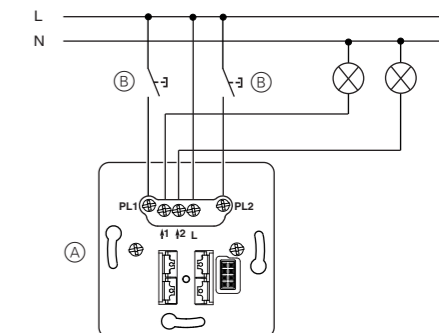

- (A) Electronic switch insert, 2-gang
- (B) Mechanical push-buttons (toggle mode)

Insert in combination with transmitting devices via PlusLink
(here shown with side controller Plus)

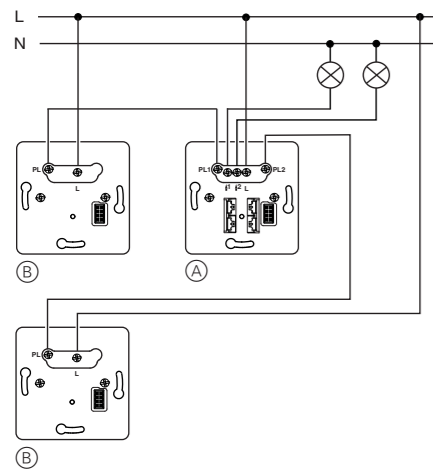

- (A) Electronic switch insert, 2-gang
- (B) Side controller Plus, 1-gang/2-gang (transmitting device)

Installing the device

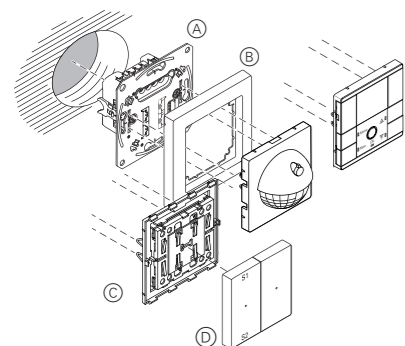

- (A) Electronic switch insert, 1-gang/2-gang
- (B) Frame
- (C) Module (see function overview)
- (D) Rockers for module

Operating the insert

i The insert is shown here in operation in combination with a push-button module. More details on how to operate the various modules can be found in the relevant operating instructions.

Switching loads on/off (1-gang insert)

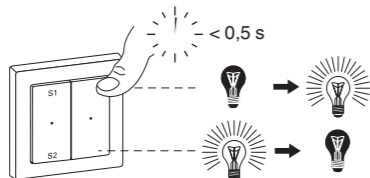

Switching loads on/off (2-gang insert)

- Right push-button: Channel 1
- Left push-button: Channel 2

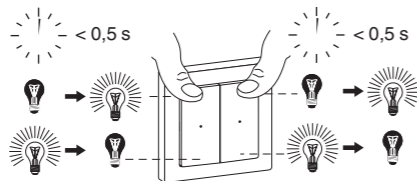

Calling up lightscenes (1-gang insert)

(only for push-button module, 2-gang)

Standard scenes

All devices are delivered from the factory with presettings for a lightscene.

- S1: Light on
- S2: Light off

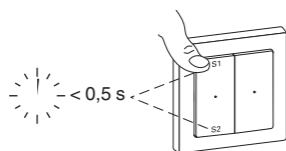

Controlling loads from another location with transmitting devices via PlusLink.
For example:

- Central unit insert with module
- Side controller Plus, 1-gang/2-gang
- Mechanical push-button
- External sensor

Example operation 1:

When the push-button module on the central unit insert is pressed, all loads in the PL line are controlled together.

- Short push-button action (<math>< 0.5 \text{ s}</math>): turn on/off

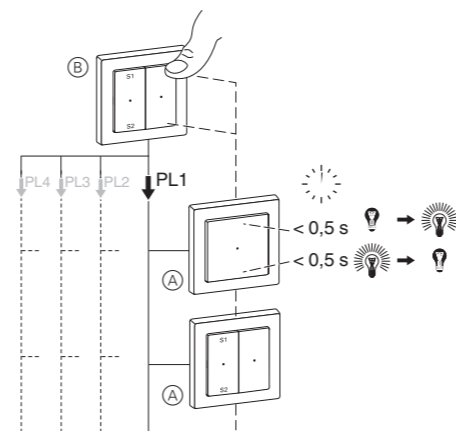

- (A) Electronic switch insert in PL line 1
- (B) Central unit insert with module

Example operation 2:

i When a mechanical push-button is used, we recommend connecting only one insert. With two or more inserts, simultaneous switching of the loads is no longer guaranteed.

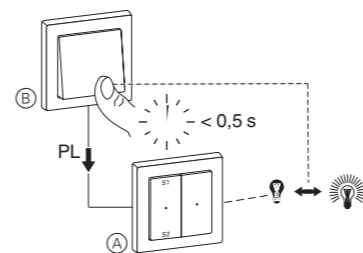

- (A) Electronic switch insert
- (B) Mechanical push-button

What should I do if there is a problem?

The device regularly switches off during operation

- Allow the device to cool down and reduce the connected load.

The load cannot be switched back on.

- Allow the device to cool down and reduce the connected load.
- Rectify any possible short circuits.
- Renew defective loads.

Technical data

Nominal voltage: AC 220/230 V ~, 50/60 Hz

MEG5151-0000
Switching capacity: 50-420 VA
Outputs: 1

MEG5152-0000
Switching capacity per channel: 50-220 VA
Outputs: 2

Neutral conductor: not required
Connecting terminals: Screw terminals for max. 2x 2.5 mm² or 2x 1.5 mm²

Protection: 16 A circuit breaker
Properties:
• Short-circuit-proof
• Overload-proof

 Dispose of the device separately from household waste at an official collection point. Professional recycling protects people and the environment against potential negative effects.

Merten GmbH

Fritz-Kotz-Str. 8
51674 Wiehl - Germany
se.com/contact

