

Low noise electronic step relays



Call and reset switches for bathrooms



Bathroom lighting control



Bedroom light control



Living room light control



Office lighting control



13
SERIES

Type 13.01 - Electronic step Bistable or monostable relay
 - Selectable Step or Monostable operation
 - Suitable for SELV applications and available also for supply 12 and 24 V AC/DC

Type 13.81 - Low noise electronic step relay Rail mount, 1 Pole

Type 13.91 - Low noise electronic step relay and timing step relay Switch box mount, 1 Pole
 - Fixed time (10 minutes) timing function selectable
 - Can be mounted behind blanking plates, as widely used in residential wiring systems such as; BTicino: Axolute, Matix, Living and Magic, Gewiss: GW24, Vimar: Plana and Idea ...

- Use with 3 or 4 wire connection, with automatic recognition by the relay
- Control input can be continuously applied
- Longer mechanical and electrical life, and much quieter than electromechanical step relays
- "Zero crossing" load switching
- 35 mm rail (EN 60715) mount
- Cadmium free contact material

13.01/13.81/13.91
Box clamp



* With DC Bistable function: (12...13.2)V DC
For outline drawing see page 13



- 1 CO (SPDT)
- Step or monostable relay
- According to EN 60601-1 2 x MOOP
- 35 mm rail (EN 60715) mount
- 35 mm wide



- 1 NO (SPST-NO)
- 35 mm rail (EN 60715) mount
- 17.5 mm wide



- 1 NO (SPST-NO)
- Step relay and timing step relay (10 minutes)
- For mounting within residential switch boxes

| Contact specification | | 1 CO (SPDT) | | 1 NO (SPST-NO) | | 1 NO (SPST-NO) | |
|---|--|-----------------------|-------------|---------------------------|--|---------------------------|--|
| Contact configuration | | 1 CO (SPDT) | | 1 NO (SPST-NO) | | 1 NO (SPST-NO) | |
| Rated current | A | 16 | | 16 | | 10 | |
| Inrush current/specific energy (I ² t) | A/A ² s | 120/3.9 | | 209/16.5 | | 170/9 | |
| Rated voltage/Maximum switching voltage | V AC | 250/400 | | 230/— | | 230/— | |
| Rated load AC1 | VA | 4000 | | 3700 | | 2300 | |
| Rated load AC15 (230 V AC) | VA | 750 | | 750 | | 450 | |
| Nominal lamp rating: | | | | | | | |
| | 230 V incandescent/halogen W | 2500 | | 3000 | | 800 | |
| | fluorescent tubes with electronic ballast W | 1000 | | 1500 | | 500 | |
| | fluorescent tubes with electromagnetic ballast W | 750 | | 1000 | | 350 | |
| | LED 230 V W | 120 | | 300 | | 200 | |
| | LED surface luminaires W | 250 | | 600 | | 250 | |
| | LED strips W | 2000 | | 3200 | | 2000 | |
| | LV halogen or LED with electronic ballast W | 400 | | 1000 | | 300 | |
| Minimum switching load | mW (V/mA) | 1000 (10/10) | | 1000 (10/10) | | 1000 (10/10) | |
| Standard contact material | | AgSnO ₂ | | AgSnO ₂ | | AgSnO ₂ | |
| Supply specification | | | | | | | |
| Nominal voltage (U _N) | V AC (50/60 Hz) | 110...125 | 230...240 | 230 | | 230 | |
| | V DC/AC (50/60 Hz) | 12 | 24 | — | | — | |
| Rated power | VA (50/60 Hz)/W | 2.5/2.5 | | 3/1.2 | | 2/1 | |
| Operating range | V AC (50/60 Hz) | 90...130 | 184...253 | (0.8...1.1)U _N | | (0.8...1.1)U _N | |
| | V DC/AC (50/60 Hz) | 10.8*...13.2 | 20.6...33.6 | — | | — | |
| Technical data | | | | | | | |
| Electrical life at rated load in AC1 | cycles | 100 · 10 ³ | | 100 · 10 ³ | | 100 · 10 ³ | |
| Maximum impulse duration | | Continuous | | Continuous | | Continuous | |
| Dielectric strength between: | open contacts V AC | 1000 | | 1000 | | 1000 | |
| | supply - contacts V AC | 4000 | | — | | — | |
| Ambient temperature range | °C | -10...+60 | | -10...+60 | | -10...+50 | |
| Protection category | | IP 20 | | IP 20 | | IP 20 | |
| Approvals (according to type) | | CE UK EAC | | CE UK EAC | | CE UK EAC | |

Low noise electronic multifunction step relays

Type 13.61.0.024.0000 - Electronic multifunction step relays Set and reset feature

- Reset feature, for centralized off command
- Set feature, for centralized on command

Type 13.61.8.230.000x - Electronic multifunction step relays Reset feature

- Reset feature, for centralized off command

Type 13.62.8.230.0001 - Electronic multifunction step relays Reset feature

- Reset feature, for centralized off command
- In case of power failure, when power is restored, the output returns to the state it was in before the power failure

- 12...24 V AC/DC and 110...240 V AC supply versions
- Control input can be continuously applied
- "Zero-crossing" load switching
- Much quieter than electromechanical step relays
- 35 mm rail (EN 60715) mount
- Cadmium free contact material

13.61/13.62
Box clamp



For outline drawing see page 13

Contact specification

| Contact configuration | | 1 CO (SPDT) | 1 NO (SPST-NO) | 2 NO (DPST-NO) |
|---|--------------------|--------------------|--------------------|--------------------|
| Rated current | A | 16 | 16 | 10 |
| Inrush current/specific energy (I ² t) | A/A ² s | 120/3.9 | 209/16.5 | 142/5.5 |
| Rated voltage/ Maximum switching voltage | V AC | 250/400 | 250/400 | 230/— |
| Rated load AC1 | VA | 4000 | 4000 | 2300 |
| Rated load AC15 (230 V AC) | VA | 750 | 750 | 450 |
| Nominal lamp rating: | | | | |
| 230 V incandescent/halogen W | | 2500 | 3000 | 1000 |
| fluorescent tubes with electronic ballast W | | 1000 | 1500 | 500 |
| fluorescent tubes with electromagnetic ballast W | | 750 | 1000 | 350 |
| LED 230 V W | | 120 | 300 | 150 |
| LED surface luminaires W | | 250 | 600 | 200 |
| LED strips W | | 2000 | 3200 | 2000 |
| LV halogen or LED with electronic ballast W | | 400 | 1000 | 300 |
| Minimum switching load | mW (V/mA) | 1000 (10/10) | 1000 (10/10) | 1000 (10/10) |
| Standard contact material | | AgSnO ₂ | AgSnO ₂ | AgSnO ₂ |

Supply specification

| | | | | |
|-----------------------------------|--------------------|-------------|-----------|-----------|
| Nominal voltage (U _N) | V AC (50/60 Hz) | — | 110...240 | 110...240 |
| | V DC/AC (50/60 Hz) | 12...24 | — | — |
| Rated power AC/DC | VA (50/60 Hz)/W | 1/0.5 | 3.2/1 | 3.2/1 |
| Operating range | V AC (50/60 Hz) | — | 90...264 | 90...264 |
| | V DC/AC (50/60 Hz) | 10.2...26.4 | — | — |

Technical data

| | | | | |
|--------------------------------------|------------------------|-----------------------|-----------------------|-----------------------|
| Electrical life at rated load in AC1 | cycles | 100 · 10 ³ | 100 · 10 ³ | 100 · 10 ³ |
| Maximum impulse duration | | Continuous | Continuous | Continuous |
| Dielectric strength between: | open contacts V AC | 1000 | 1000 | 1000 |
| | supply - contacts V AC | 2000 | 2000 | — |
| Ambient temperature range | °C | -10...+60 | -10...+60 | -10...+60 |
| Protection category | | IP 20 | IP 20 | IP 20 |

Approvals (according to type)



13.61.0.024.0000



- 1 CO (SPDT)
- Reset feature, for centralized off command (3s)
- Set feature, for centralized on command
- Multifunction:
 - step relay (RI)
 - timing step relay (30 s...20 min) (IT)
 - monostable (RM)
 - light ON
- 35 mm rail (EN 60715) mount
- 17.5 mm wide

13.61.8.230.000x



- 1 NO (SPST-NO)
- Reset feature, for centralized off command:
 - reset 3s (13.61-0000)
 - reset 1s (13.61-0001)
- Functions:
 - step relay (RI)
 - timing step relay (30 s...20 min) (IT)
 - monostable (RM)
 - light ON
- 35 mm rail (EN 60715) mount
- 17.5 mm wide

NEW

13.62.8.230.0001



- Output: double pole breaking (L and N)
- In case of a power failure, when power is restored, the output returns to the state it was in before the power failure
- Terminal Reset for central OFF (1s)
- Functions:
 - step relay (RI)
 - timing step relay (IT)
 - step relay with power failure restoration (RIm)
 - timing step relay with power failure restoration (ITm)
- 35 mm rail (EN 60715) mount
- 17.5 mm wide

**Type 13.11 - Call & Reset Relay
Rail mount, 1 Pole**

- Call relay with reset command suitable for residential and commercial applications: public bathroom, hospital, hotel

**Type 13.12 - Call & Reset Relay
Rail mount, 2 Pole**

- Call relay with reset command suitable for residential and commercial applications: public bathroom, hospital, hotel

**Type 13.31 - Electromechanical monostable relay
Switch box mount, 1 Pole**

- Can be mounted behind blanking plates, as widely used in residential wiring systems such as; BTicino: Axolute, Matix, Living e Magic, Gewiss: GW24, Vimar: Plana e Idea ...

- 35 mm rail (EN 60715) or flange mount
- Cadmium free contact material

13.11/13.12/13.31
Box clamp



* During impulse only.

For outline drawing see page 13



- 1 CO (SPDT)
- Call relay with reset command
- 35 mm rail (EN 60715) mount
- 17.5 mm wide



- 1 CO (SPDT) + 1 NO (SPST-NO)
- Call relay with reset command
- 35 mm rail (EN 60715) mount
- 17.5 mm wide



- 1 NO (SPST-NO)
- Interposing monostable relay
- For mounting within residential switch boxes

Contact specification

| Contact configuration | 1 CO (SPDT) | 1 CO (SPDT) + 1 NO (SPST-NO) | 1 NO (SPST-NO) |
|--|---------------------------|------------------------------|---------------------------|
| Rated current A | 12 | 8 | 12 |
| Inrush current/specific energy (I ² t) A/A ² s | — | — | 170/9 |
| Rated voltage/ Maximum switching voltage V AC | 250/400 | 250/400 | 250/400 |
| Rated load AC1 VA | 3000 | 2000 | 3000 |
| Rated load AC15 (230 V AC) VA | 750 | 400 | 450 |
| Nominal lamp rating: | | | |
| 230 V incandescent/halogen W | — | — | 800 |
| fluorescent tubes with electronic ballast W | — | — | 400 |
| fluorescent tubes with electromagnetic ballast W | — | — | 300 |
| 230 V LED W | — | — | 200 |
| LED surface luminaires W | — | — | 250 |
| LED strips W | — | — | 2000 |
| LV halogen or LED with electronic ballast W | — | — | 300 |
| Minimum switching load mW (V/mA) | 500 (5/5) | 300 (5/5) | 1000 (10/10) |
| Standard contact material | AgNi | AgNi | AgSnO ₂ |
| Supply specification | | | |
| Nominal voltage (U _N) V AC (50/60 Hz) | 230...240 | 12 - 24 | 12 - 230 |
| V DC | — | 12 - 24 | 24 |
| Rated power AC/DC VA (50 Hz)/W | 1.7/0.7* | 3/2.5* | 1/0.4 |
| Operating range AC (50 Hz) | (0.8...1.1)U _N | (0.8...1.1)U _N | (0.8...1.1)U _N |
| DC | — | (0.8...1.1)U _N | (0.8...1.1)U _N |
| Technical data | | | |
| Electrical life at rated load in AC1 cycles | 100 · 10 ³ | 100 · 10 ³ | 70 · 10 ³ |
| Maximum impulse duration | 10 s (100 ms minimum) | 10 s (100 ms minimum) | Continuous |
| Dielectric strength between: open contacts V AC | 1000 | 1000 | 1000 |
| supply - contacts V AC | 2000 | 2000 | 2000 |
| Ambient temperature range °C | -10...+60 | -10...+60 | -10...+60 |
| Protection category | IP 20 | IP 20 | IP 20 |

Approvals (according to type)



Ordering information

Example: multifunction, 2 NO (DPST-NO), 10 A, 110...240 V AC supply.

| | | | |
|---|--|--|---|
| <p>Series _____</p> <p>Type _____</p> <p>0 = Step/Monostable, 35 mm rail (EN 60715) mount, 35 mm wide</p> <p>1 = Call & Reset relay, 35 mm rail (EN 60715) mount, 17.5 mm wide</p> <p>3 = Monostable relay, switch box mounting</p> <p>6 = Multifunction relay, 35 mm rail (EN 60715) mount, 17.5 mm wide</p> <p>8 = Modular step relay, 35 mm rail (EN 60715) mount, 17.5 mm wide</p> <p>9 = Step relay and timing step relay, switch box mounting</p> <p>No. of poles _____</p> <p>1 = 1 CO</p> <p>1 = 1 NO</p> <p>2 = 1 CO + 1 NO</p> <p>2 = Double pole breaking (13.62)</p> <p>Supply version _____</p> <p>0 = AC (50/60 Hz)/DC</p> <p>8 = AC (50/60 Hz)</p> <p>9 = DC</p> <p>Supply voltage _____</p> <p>012 = 12 V AC</p> <p>012 = 12 V AC/DC</p> <p>024 = 24 V DC</p> <p>024 = 24 V AC/DC</p> <p>024 = 12...24 V AC/DC</p> <p>125 = 110...125 V AC</p> <p>230 = 230...240 V AC</p> <p>230 = 110...240 V AC</p> <p>230 = 230 V AC</p> | <p>1 3 . 6 2 . 8 . 2 3 0 0 0 0 1</p> | <p>A: Contacts material</p> <p>0 = Standard</p> <p>4 = Standard AgSnO₂ (only for 13.31)</p> <p>B: Contact circuit</p> <p>0 = Standard</p> <p>3 = Standard NO (only for 13.31)</p> <p>Codes / Supply voltage</p> <p>13.01.0.012.0000 (12 V AC/DC)</p> <p>13.01.0.024.0000 (24 V AC/DC)</p> <p>13.01.8.125.0000 (110...125 V AC)</p> <p>13.01.8.230.0000 (230...240 V AC)</p> <p>13.11.8.230.0000 (230...240 V AC)</p> <p>13.12.0.012.0000 (12 V AC/DC)</p> <p>13.12.0.024.0000 (24 V AC/DC)</p> <p>13.31.8.012.4300 (12 V AC)</p> <p>13.31.9.024.4300 (24 V DC)</p> <p>13.31.8.230.4300 (230 V AC)</p> <p>13.61.8.230.0000 (110...240 V AC)</p> <p>13.61.8.230.0001 (110...240 V AC)</p> <p>13.61.0.024.0000 (12...24 V AC/DC)</p> <p>13.62.8.230.0001 (110...240 V AC)</p> <p>13.81.8.230.0000 (230 V AC)</p> <p>13.91.8.230.0000 (230 V AC)</p> | <p>0 = Type 13.61 (Reset 3s)</p> <p>1 = Type 13.61 and 13.62 (Reset 1s)</p> |
|---|--|--|---|

Technical data

| Insulation | | 13.01.8 | 13.01.0 | 13.11 - 13.12 | 13.31 - 13.61 | 13.62 | 13.81 - 13.91 | |
|---|-----------------|-----------------|-----------------|---------------------------------------|-----------------|-----------------|-----------------|-------|
| Dielectric strength | | | | | | | | |
| between control circuit and supply | V AC | 4000 | — | — | — | — | — | |
| between control circuit and contacts | V AC | 4000 | 4000 | — | — | — | — | |
| between R-S-A2 and contacts | V AC | — | — | 2000 | — | — | — | |
| between supply and contacts | V AC | 4000 | 4000 | — | 2000 | — | — | |
| between open contacts | V AC | 1000 | 1000 | 1000 | 1000 | 1000 | 1000 | |
| Other data | | 13.01 | | 13.11 - 13.12 | 13.31 | 13.61 - 13.62 | 13.81 | 13.91 |
| Power lost to the environment | | | | | | | | |
| without contact current | W | 2.2 | | — | 0.4 | 1 | 1.2 | 0.7 |
| with rated current | W | 3.5 | | 1.5 | 1.6 | 1.8 | 2 | 1.8 |
| Max cable length for push-button connection | m | 100 | | 100 | — | 200 | 200 | 100 |
| Max. no. of illuminated push-button | (≤1mA) | — | | — | — | 10* | 15 | 12 |
| Terminals | | 13.01 | | 13.11 - 13.12 - 13.31 - 13.62 - 13.81 | | 13.61 - 13.91 | | |
| Max. wire size | | solid cable | stranded cable | solid cable | stranded cable | solid cable | stranded cable | |
| | mm ² | 1 x 6 / 2 x 4 | 1 x 6 / 2 x 2.5 | 1 x 6 / 2 x 4 | 1 x 4 / 2 x 2.5 | 1 x 4 / 2 x 2.5 | 1 x 4 / 2 x 2.5 | |
| | AWG | 1 x 10 / 2 x 12 | 1 x 10 / 2 x 14 | 1 x 10 / 2 x 12 | 1 x 12 / 2 x 14 | 1 x 12 / 2 x 14 | 1 x 12 / 2 x 14 | |
| Screw torque | Nm | 0.8 | | | 0.8 | | | |

* For 8.230 version.

K

Functions for types 13.01, 13.11, 13.12, 13.81, 13.91

| Type | Functions | |
|----------------|-----------|---|
| 13.01 | | Monostable. On closure of a switch between terminals (B2-B3) the output contact will close, and remain so, until the switch opens. |
| | | Step relay (bistable). After every impulse (B1-B2), the output contact changes state - alternately switching from open to closed and vice versa. |
| 13.11 13.12 | | Call and Reset relay. On momentary closure of the Set switch (S), the output contact closes. Only a momentary closure of the Reset switch (R) will open the output contact. |
| 13.81 | | (RI) Step relay. After every impulse, the output contact changes state - alternately switching from open to closed and vice versa. |
| 13.91 | | (RI) Step relay. After every impulse, the output contact changes state - alternately switching from open to closed and vice versa. |
| | | (IT) Timing step relay. On initial impulse the output contact closes and timing starts for the pre-set duration (fixed 10 min); On expiry of the time delay, the output contact opens. During the timing period it is possible to immediately open the contact with a further impulse. |

Operating mode setup for type 13.91

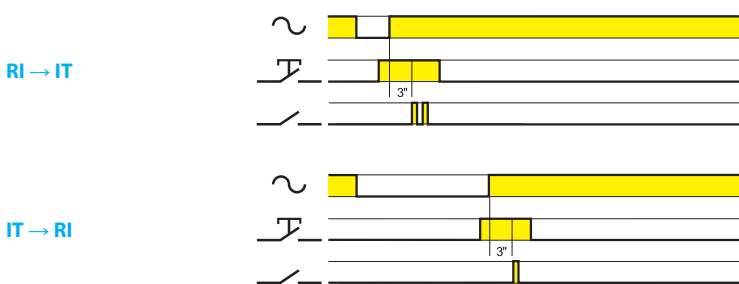

- Remove the supply voltage
- Press the control button
- Apply the supply to the relay, keeping the button closed.
After 3 second, the light will flash twice to indicate the selection of the "IT" function, or flash once for "RI" function.

Functions for type 13.61

| Type | Functions |
|-------------|---|
| 13.61.8.230 | <p>(RM) Monostable. On closure of a switch between terminal 3 and Line (or Neutral, in case of 3-wire connection) the output contact will close, and remain so, until the switch opens. * $T \geq 1s$. - Type 13.61.8.230.0001</p> |
| | <p>(IT) Timing step relay. On initial impulse the output contact closes and timing starts for the pre-set duration T; On expiry of the time delay, the output contact opens. During the timing period it is possible to immediately open the contact with a further impulse. Switch-off delay time: 30 s...20 min. * $T \geq 1s$. - Type 13.61.8.230.0001</p> |
| | <p>(RI) Step relay. After every impulse, the output contact changes state - alternately switching from open to closed and vice versa. * $T \geq 1s$. - Type 13.61.8.230.0001</p> |
| | <p>Light ON. With this function set - the output contact stays permanently closed. * $T \geq 1s$. - Type 13.61.8.230.0001</p> |
| 13.61.0.024 | <p>(RM) Monostable. On closure of a switch between terminal 3 and Line (or Neutral, in case of 3-wire connection) the output contact will close, and remain so, until the switch opens. * $T \geq 1s$. - Type 13.61.0.024.0001</p> |
| | <p>(IT) Timing step relay. On initial impulse the output contact closes and timing starts for the pre-set duration T; On expiry of the time delay, the output contact opens. During the timing period it is possible to immediately open the contact with a further impulse. Switch-off delay time: 30 s...20 min.</p> |
| | <p>(RI) Step relay. After every impulse, the output contact changes state - alternately switching from open to closed and vice versa.</p> |
| | <p>Light ON. With this function set - the output contact stays permanently closed.</p> |

Functions for type 13.62

| Type | Functions |
|-------------|--|
| 13.62.8.230 | <p>(RI) Step relay. After every impulse, the output contact changes state - alternately switching from open to closed and vice versa.</p> |
| | <p>(RI)m Step relay with power failure restoration. After every impulse, the output contact changes state - alternately switching from open to closed and vice versa. In case of power failure, when power is restored, the output returns to the state it was in before the power failure.</p> |
| | <p>(IT) Timing step relay. On initial impulse the output contact closes and timing starts for the pre-set duration T; On expiry of the time delay, the output contact opens. During the timing period it is possible to immediately open the contact with a further impulse. Switch-off delay time: 30 s...20 min.</p> |
| | <p>(IT)m Timing step relay with power failure restoration. On initial impulse the output contact closes and timing starts for the pre-set duration T; On expiry of the time delay, the output contact opens. During the timing period it is possible to immediately open the contact with a further impulse. Switch-off delay time: 30 s...20 min. In case of a power failure, when power is restored, the output returns to the state it was in before the power failure.</p> |

Wiring diagrams

Type 13.01
Step wiring diagram

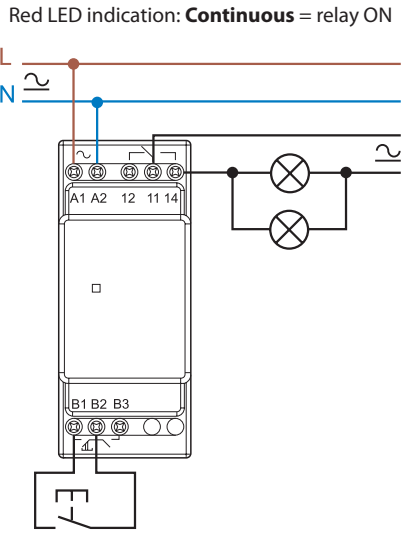

Type 13.01
Monostable wiring diagram

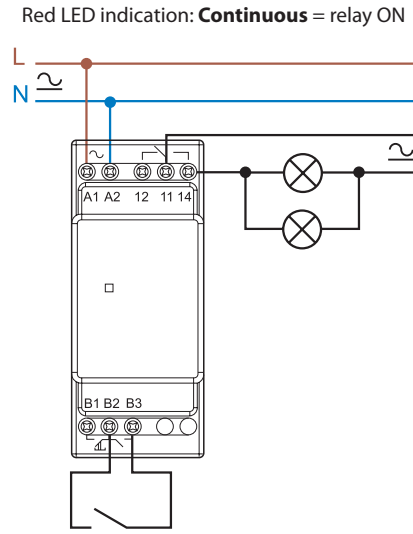

Type 13.11
Call & reset relay

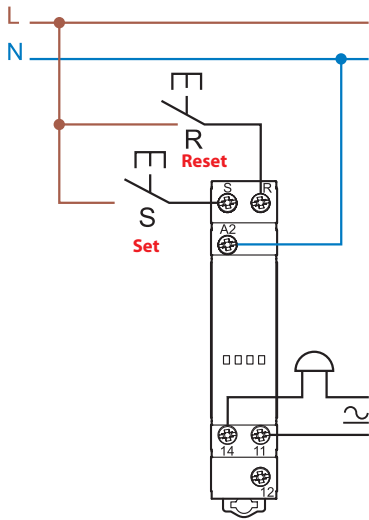

Type 13.12
Call & reset relay

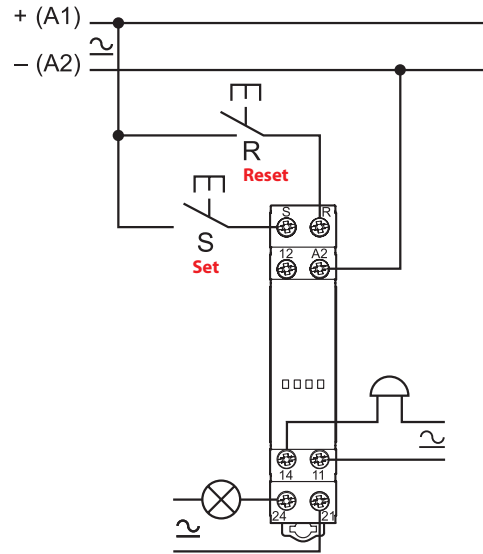

Type 13.31
Connection

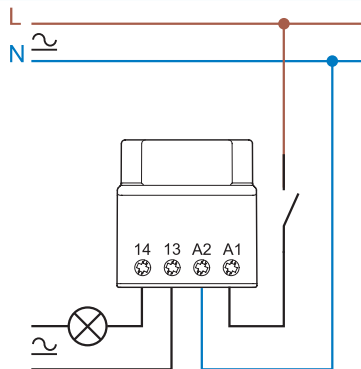

K

Wiring diagrams

Type 13.61.8.230
3 wire connection

Red LED indication: **Continuous** = relay ON; **Flashing** = relay OFF

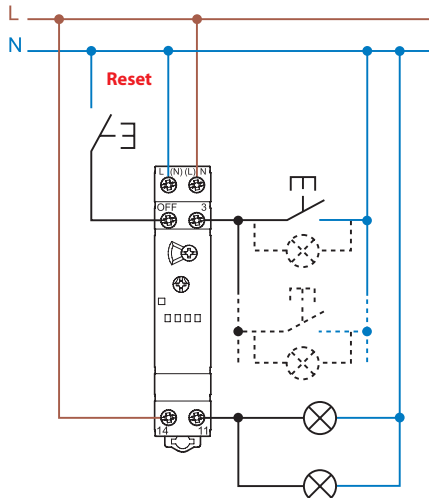

Maximum 10 mA illuminated push-buttons

Type 13.61.8.230
4 wire connection

Red LED indication: **Continuous** = relay ON; **Flashing** = relay OFF

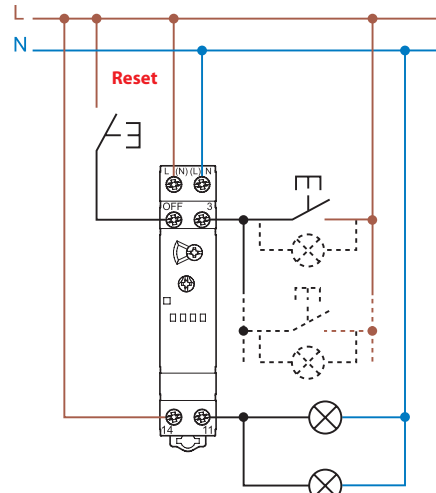

Maximum 10 mA illuminated push-buttons

Type 13.61.0.024
4 wire connection

Red LED indication: **Continuous** = relay ON; **Flashing** = relay OFF

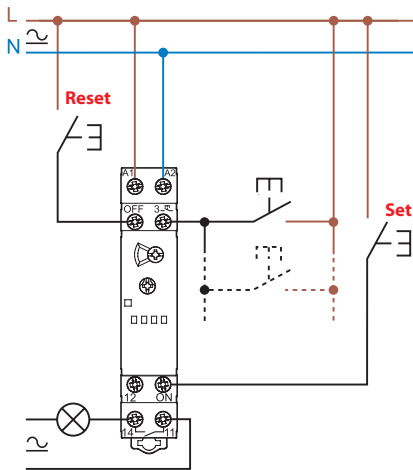

Type 13.62.8.230
4 wire connection

Red LED indication: **Continuous** = relay ON; **Flashing** = relay OFF

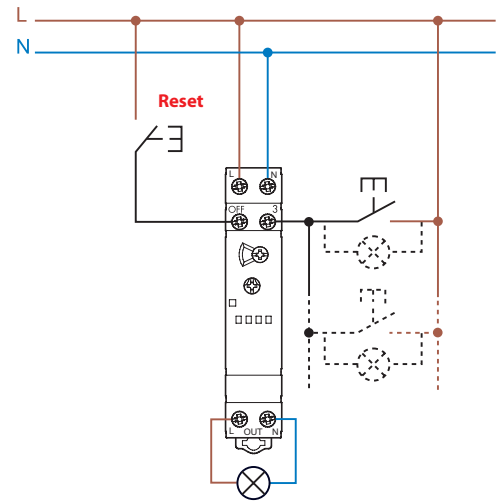

Type 13.61.8.230 - Examples of multiple 4 wire connection with centralized reset push-button

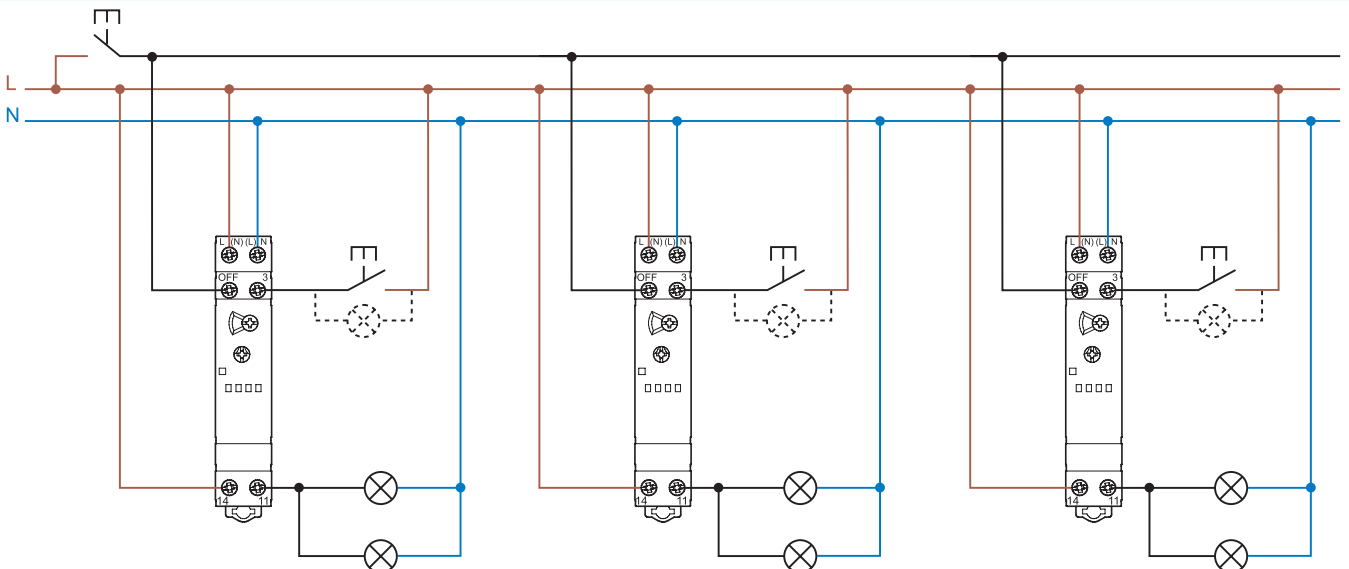

Wiring diagrams

Type 13.81

3 wire connection

Red LED indication: **Continuous** = relay ON; **Flashing** = relay OFF

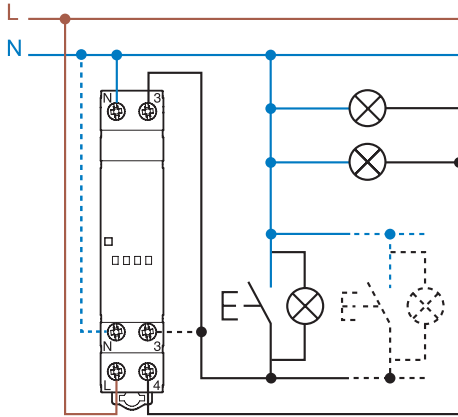

Maximum 15 mA illuminated push-buttons

Type 13.81

4 wire connection

Red LED indication: **Continuous** = relay ON; **Flashing** = relay OFF

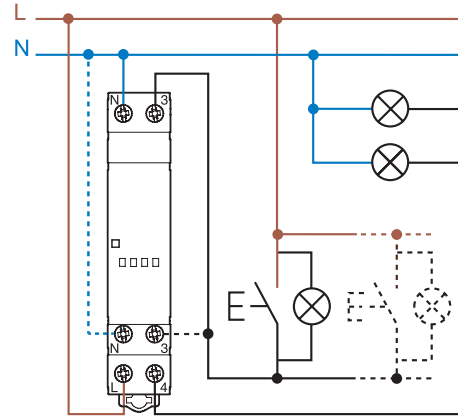

Maximum 15 mA illuminated push-buttons

Type 13.91

3 wire connection

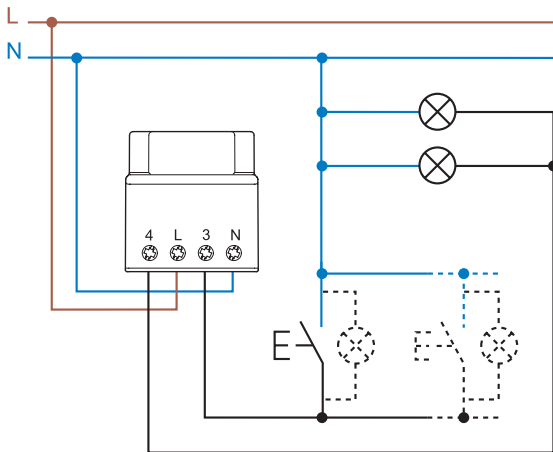

Maximum 12 mA illuminated push-buttons

Type 13.91

4 wire connection

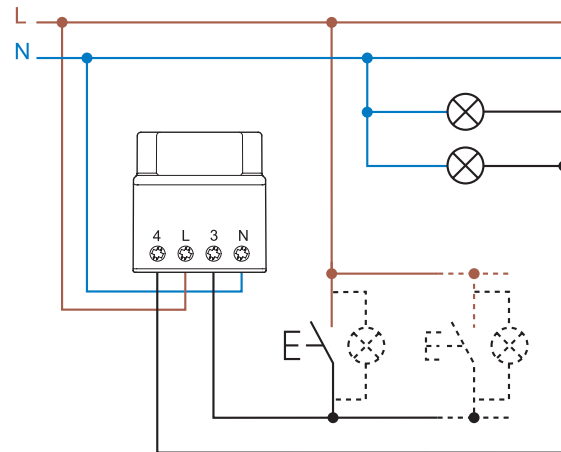

Maximum 12 mA illuminated push-buttons

Outline drawings

Type 13.01
Box clamp

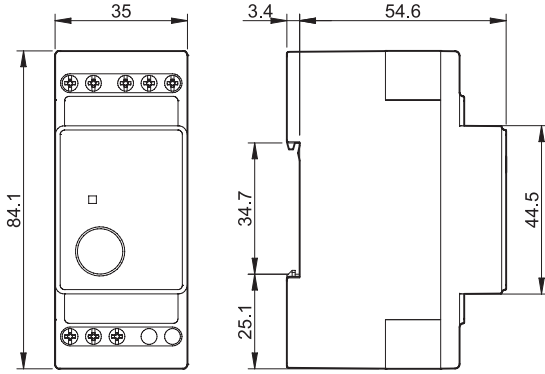

Type 13.11
Box clamp

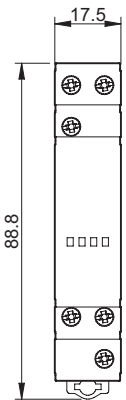

Type 13.12
Box clamp

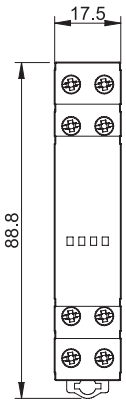

Type 13.61.0.024.0000
Box clamp

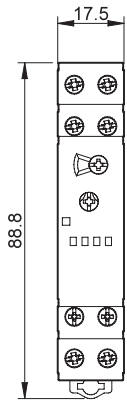

Type 13.61.8.230.000x
Box clamp

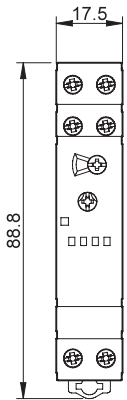

Type 13.62
Box clamp

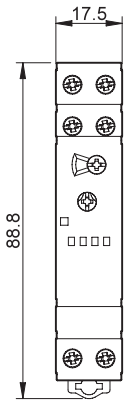

Type 13.81
Box clamp

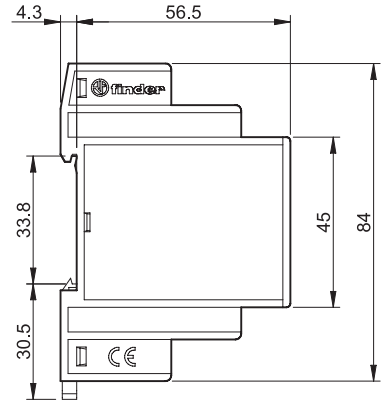
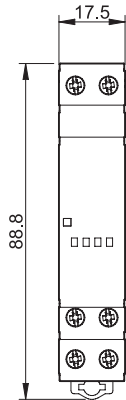

Type 13.31/13.91
Box clamp

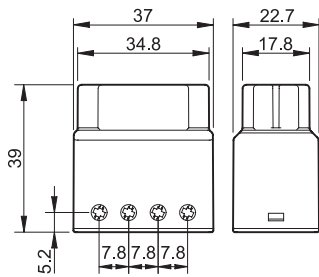

Accessories



011.01

Adaptor for panel mounting, for Type 13.01, 35 mm wide

011.01

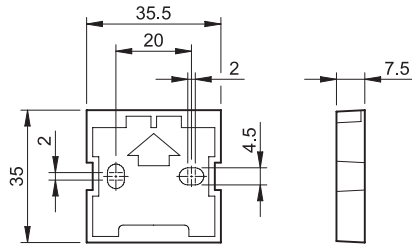

020.01

Adaptor for panel mounting, for Types 13.11, 13.12, 13.61, 13.62 and 13.81, 17.5 mm wide

020.01

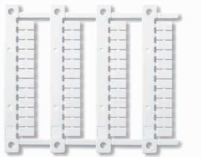
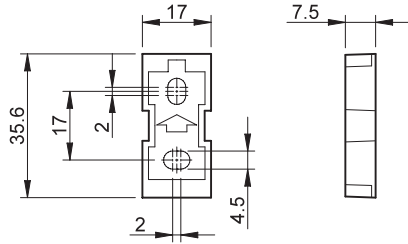

060.48

Sheet of marker tags (CEMBRE Thermal transfer printers) for relays Types 13.11, 13.12, 13.61, 13.62 and 13.81 (48 tags), 6 x 12 mm

060.48



013.00

Push-button phase/neutral converter. Use this with a pre-existing neutral wired push-button when retro fitting a device designed only for phase connected push-buttons. This avoids any radical change to the existing wiring.

013.00

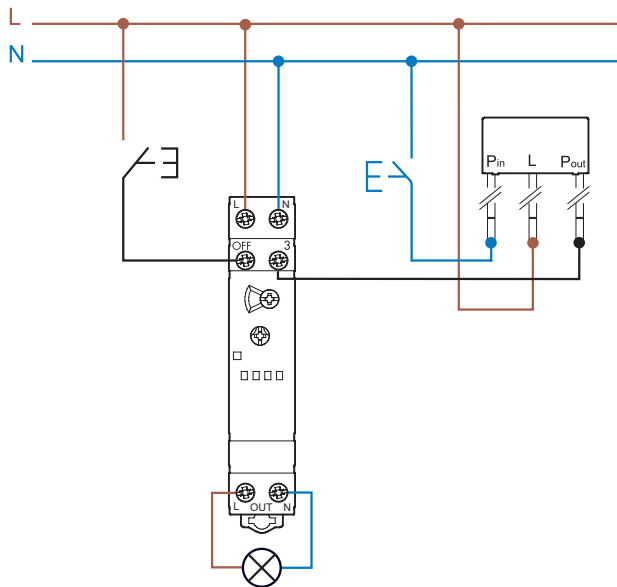

K



013.26

Adaptor for panel mounting, for Types 13.31, 13.91

013.26

