

## BROADWAY LINEAR LUMINAIRE INSTRUCTIONS

Issue 01 March 2026

### Thank you for your purchase

For best results, have this light fitting installed by a qualified electrician, following these instructions. Keep this leaflet for future reference.

### Safety

- Mains powered – installation must comply with building and electrical regulations.
- Always switch off and isolate the power before installation or maintenance.



### Need Help?

For advice or accessories, contact us at the address above. Please have the product name, model, and purchase details ready.

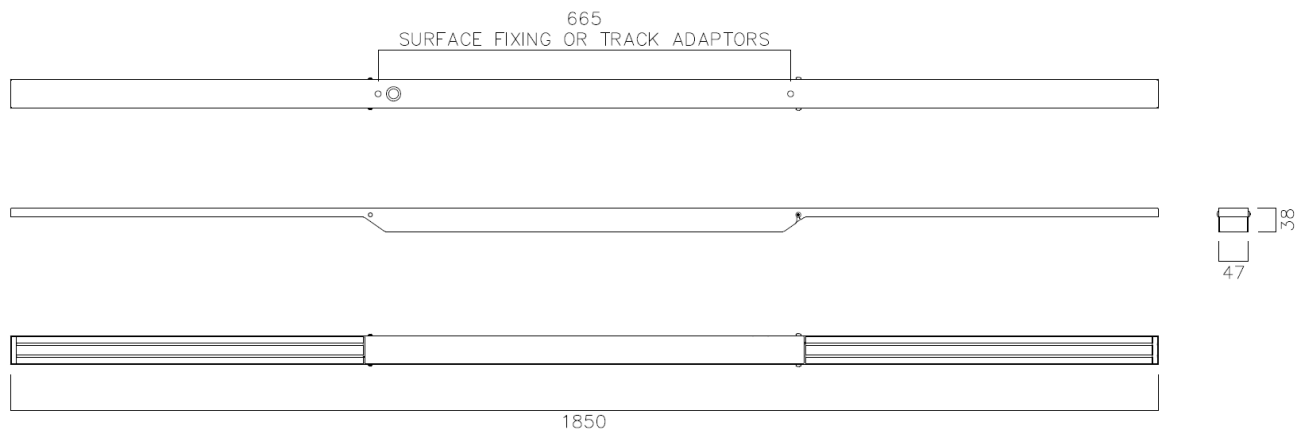

### INSTALLATION

- Unplug the power supply before installation of the luminaire
- Once track adaptors are installed on to the Broadway fitting, install the fitting into compatible track. Ensure correct direction and wiring into the track to align with the fitting.

### MAINTENANCE

1. Gentle cleaning of the diffuser should be carried out at regular intervals so as not impair photometric performance of the luminaire.

### DD DIMMING VERSIONS

#### TYPE OF DIMMING

This product uses an LED driver that is capable of 2 methods of dimming:

#### DALI

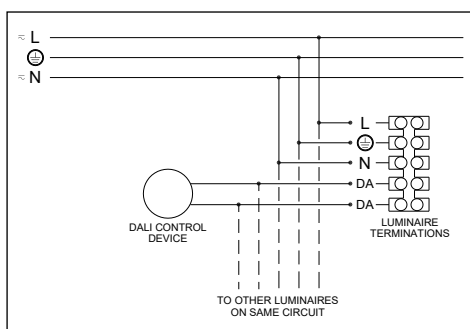

#### SWITCH-DIM

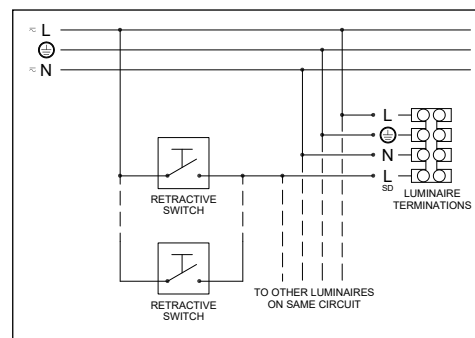

### REMOTE DRIVER WIRING

Power supply & signal wires input for luminaires with remote mounted LED drivers (i.e. driver not inside luminaire).

**Important: The make of LED driver will need to be identified so the correct wiring can be followed.**

Dimming via a Digital Addressable Lighting Interface.

**Further input may be required from your lighting controls provider.**

Dimming via a retractive switch.

**Different makes of control gear should never be actuated by the same retractive switch in an installation. There is a risk of a conflict in what you are asking the ballast to do.**

### INTERNAL DRIVER WIRING

Power supply & signal wires input for luminaires with built in LED driver & where there is a terminal block present

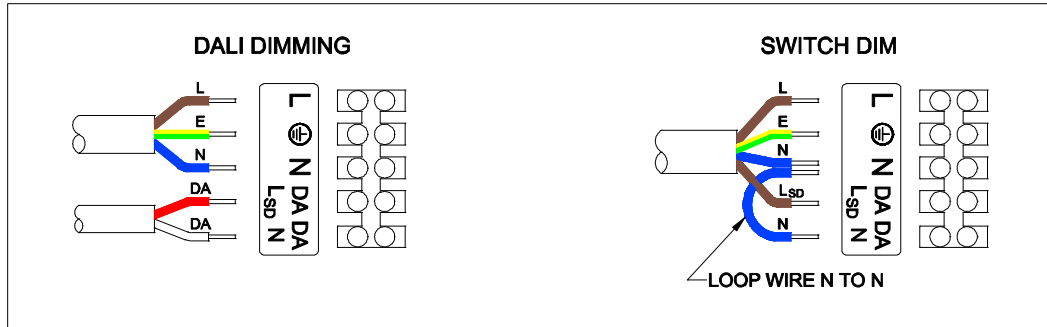

Note: L<sub>SD</sub> = Switch Dim Live