

Universal

# MaxiFit

Wide Tolerance Range

Mechanical Pipe Fitting Technology

**NOW  
INCLUDES  
MaxiFit  
Plus**



**VIKING JOHNSON™**

PIONEERS IN PIPE SOLUTIONS

**CRANE**

BUILDING SERVICES & UTILITIES



## Overview

# A Versatile Solution for Pipe Jointing

MaxiFit universal pipe couplings are designed to accommodate plain ended pipes with different outside diameters. One fitting is able to connect a wide variety of pipe materials including steel, ductile iron, PVC, cast iron, GRP and asbestos cement pipes amongst others. The range includes the following product lines

- MaxiFit Plus – DN50 – DN150
- MaxiFit small diameter – DN40 – DN300
- MaxiFit large diameter – DN350 – DN700

The MaxiFit range is designed and manufactured under quality management systems to BS EN ISO 9001 and meets the requirements of the UK Water Regulations & EN 14525.

### Wide Tolerance

With up to 34mm tolerance on the pipe OD it not only eases installation but can reduce the need for expensive and time consuming trial holes, reduce stock holding and increase stock turn over. MaxiFit is an adaptable and economic solution to most pipe connections.

All products in the range have a test pressure of 24bar on water (9bar on gas) and are suitable for 16bar working pressure for water (6bar on gas).

### Extensive Range

The expansive range is available in sizes DN40 up to DN700 and includes MaxiFit couplings & MaxiFit Xtra long sleeved couplings, MaxiStep reducing couplings, MaxiDaptor flange adaptors, MaxiCap, MaxiThread End Cap, & MaxiFit Large Diameter couplings & flange adaptors. New to range is MaxiFit Plus couplings and flange adaptors.

### Quick & Efficient Installation

The versatile range is pre-assembled with an innovative gasket which has 'slide easy' ribs that reduce friction on pipes at the upper tolerance range of the fitting, providing maximum sealing pressure, even on scored, pitted and corroded pipe surfaces. The captive non-rotating bolt heads require just a single spanner to install with just one standard bolt torque across the range. The MaxiFit Plus range offers better access to bolts when installing, even in narrow and congested trench conditions.



MaxiThread  
MaxiStep  
MaxiDaptor  
MaxiFit Plus Flange Adaptor  
MaxiFit Coupling  
Large Diameter MaxiFit Coupling  
Large Diameter MaxiDaptor  
MaxiFit Plus Coupling

### Pipe Materials



**MaxiFit can also be used as a repair product - see the MaxiFit Repair brochure for more information.**

# MaxiFit Plus Range

## Product Design Benefits

### Optimised Gasket Design

A unique gasket with distinctive circumferential ribs provides a 'slide easy' fit for maximum sealing on scored, corroded or pitted pipe.

### Excellent Corrosion & Damage Resistance

Coated in black Rilsan Nylon 11 which is WRAS listed and has excellent resistance to impact, abrasion, weathering and chemicals. It also has good thermal stability and flexibility to accommodate for rough site handling.

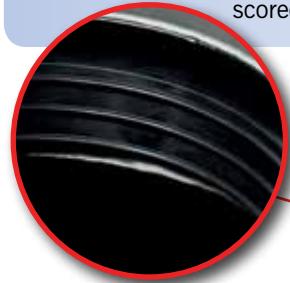

### Flexible Fit

Flared end to the sleeve forms a deep gasket chamber to give maximum possible pipe adjustment.

### Simple Installation

Unique 3 bolt system for quicker and easier installation even in a narrow trench by using readily available hand tools.

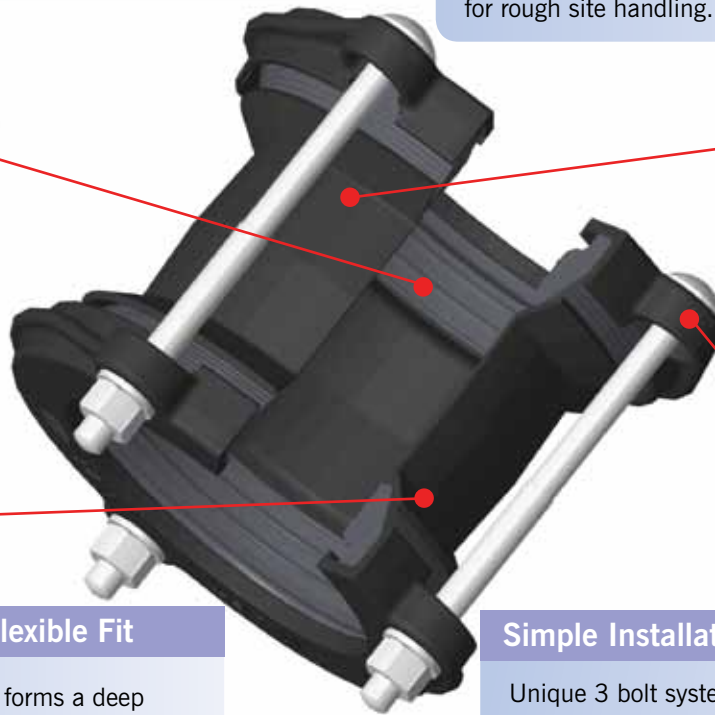

Couplings & Flange Adaptors

Wide Tolerance

## Customer Benefits

- ▶ Unique three bolt design that allows quicker installation thereby reducing trench risk, available in sizes DN65, DN80 and DN100
- ▶ MaxiFit Plus offers better leverage for torque
- ▶ Better access to bolts especially when installing in narrow or harsh trench conditions
- ▶ Design life expectancy of 50 years, established by rigorous 'Accelerated Age Testing' which subjects product to working pressure at 80°C for 1000 hours
- ▶ Lighter product for easier handling, storage and shipping, thereby reducing costs. MaxiFit Plus available in sizes DN50 to DN150
- ▶ Wide tolerance permits lower stock holding
- ▶ All models accommodate angularity between pipes, allowing for normal pipeline movement caused by ground settlement\*
- ▶ A rigorous bolt torque test is completed to confirm that the bolt, end ring and adaptor body are capable of withstanding bolt over-tightening to 1.5 times maximum recommended torque

**Note:**  
\*Angularity - Couplings and reducing couplings: offer a maximum of 6° degrees total angular deflection. Flange Adaptors: offer a maximum of 3° degrees total angular deflection; these figures are calculated when using the product on maximum pipe outside diameters. Larger degrees of angular deflection are achievable when product is fitted on smaller pipe outside diameters.

# MaxiFit Plus DN50 – DN150

## Specifications

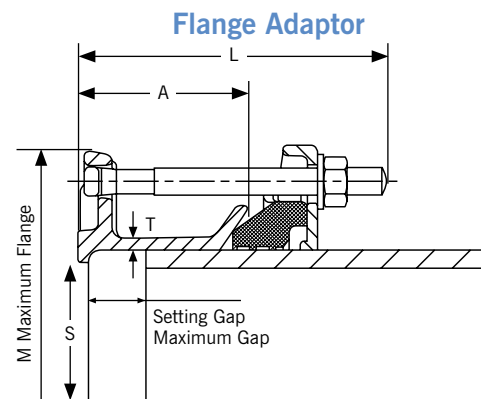
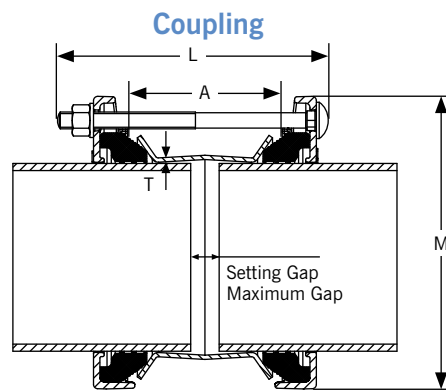

### MaxiFit Plus Couplings & End Caps

Nominal Size (mm)	Size Range (mm)		Diameter (mm) M	Overall Length (mm) L	Sleeve Length x Thickness (A) x (T)	Sleeve	Setting Gap (mm)		Bolts No-Dia X Length	Gasket Mould	Weight Kg	MaxiCap Available
	Min	Max					Min	Max				
DN50	57	74	154.5	190	95 x 3	Steel	20	40	4-M12x180	12392/1	2.7	✓
DN65	63	85	173.5	190	95 x 4.5	Ductile Iron	20	40	3-M12x180	12392/2	3.6	✓
DN65	63	85	173.5	190	95 x 3	Steel	20	40	3-M12x180	12392/2	3.2	✓
DN80	85	107	195.5	190	95 x 4.5	Ductile Iron	20	40	3-M12x180	12392/3	4.1	✓
DN80	85	107	195.5	190	95 x 3	Steel	20	40	3-M12x180	12392/3	3.7	✓
DN100	107	132	224.5	190	95 x 4.5	Ductile Iron	20	40	3-M12x180	12392/4	5.0	✓
DN100	107	132	224.5	190	95 x 3	Steel	20	40	3-M12x180	12392/4	4.5	✓
DN125	132	158	254.5	190	95 x 3	Steel	20	40	4-M12x180	12392/6	5.2	✓
DN150	158	184	280.5	190	95 x 3	Steel	20	40	4-M12x180	12392/7	6	✓

### MaxiFit Plus Flange Adaptors

Nominal Size (mm)	Size Range (mm)		Diameter (mm) M	Bore (mm) S	Overall Length (mm) L	Sleeve Length x Thickness (A) x (T)	Flange Drilling	Setting Gap (mm)		Bolts No-Dia X Length	Gasket Mould	Weight Kg
	Min	Max						Min	Max			
DN65	63	85	196.9	75	124	75 x 5	60 PN10:16, 65 PN10:16, 80 PN10:16, 3" BS10 Table ADE, 2.5" ANSI125, 3" ANSI125, 80 AS2129 CD, 80 AS4087 16	20	40	3-M12 x 115	12392/2	3.6
DN80	85	107	202.5	101	124	75 x 5	80 PN10:16, 3" ANSI125, 3.5" BS10 Table AD, 3.5" BS10 Table E	20	40	3-M12 x 115	12392/3	3.8
DN100	107	132	228	121	134	75 x 5	100 PN10:16, 4" BS10 Table AD, 4" BS10 Table E, 4" AWWAC207 D, 100 AS2129 CD, 100 AS4087 16	20	40	3-M12 x 125	12392/4	4.7

**Note:**

For other sizes of flange adaptors, please see MaxiDapter Flange Adapter section.

\*Angularity - Couplings and reducing couplings: offer a maximum of 6° degrees total angular deflection. Flange Adaptors: offer a maximum of 3° degrees total angular deflection; these figures are calculated when using the product on maximum pipe outside diameters. Larger degrees of angular deflection are achievable when product is fitted on smaller pipe outside diameters.

### Materials & Relevant Standards

**End Ring and Adaptor Body**

Ductile Iron to BS EN 1563 Symbol EN GJS-450-10

**Centre Sleeve**

Sleeve material is rolled Steel to BS EN10025-2 grade S275 or Ductile Iron to BS EN1563 symbol EN GJS-450-10 Compliance with EN 14525

**Gasket**

EPDM compound Grade E to BS EN 681-1, Type WA, WC  
Nitrile compound to Grade G BS EN 682, Type G

**Tee Bolts/Bolts**

Steel to BS EN ISO 898-1 Property Class 4.8

**Bolt Torque/Spanner**

Bolt torque 55-65Nm, Spanner size A/F 19mm

**Nuts**

Steel to BS EN 4190 Grade 4

**Washers**

Stainless Steel to BS 1449:Part 2 Grade 304S15 Standard

The full MaxiFit Range consists of:

- MaxiFit Plus
- MaxiFit
- MaxiFit Xtra
- MaxiStep
- MaxiDaptor
- MaxiFit Large Diameter
- MaxiCap
- MaxiThread End Cap

For further info visit:  
[www.vikingjohnson.com](http://www.vikingjohnson.com)

# MaxiFit Range

## Product Design Benefits

### Optimised Gasket Design

A unique gasket with distinctive circumferential ribs provides a 'slide easy' fit for maximum sealing on scored, corroded or pitted pipe.

### Excellent Corrosion & Damage Resistance

Coated in black Rilsan Nylon 11 which is WRAS listed and has excellent resistance to impact, abrasion, weathering and chemicals. It also has good thermal stability and flexibility to accommodate for rough site handling.

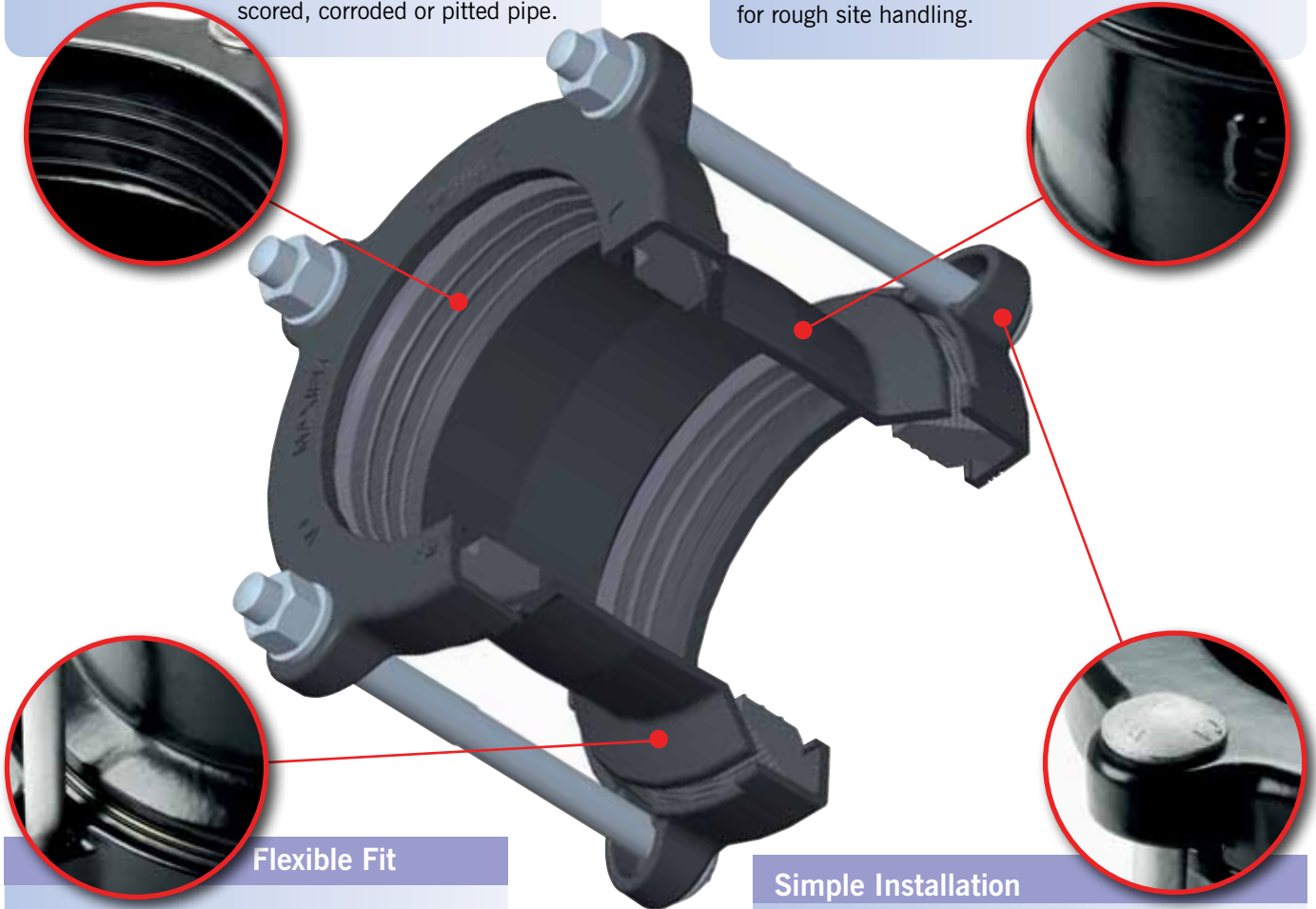

### Flexible Fit

Flared end to the sleeve forms a deep gasket chamber to give maximum possible pipe adjustment.

### Simple Installation

Captive, non-rotating bolt heads require just a torque wrench to install.

Couplings & Flange Adaptors

Wide Tolerance

## Customer Benefits

- ▶ Design life expectancy of 50 years, established by rigorous 'Accelerated Age Testing' which subjects product to working pressure at 80°C for 1000 hours.
- ▶ Wide tolerances permit lower stock holding.
- ▶ All models accommodate angularity between pipes which allows for normal pipeline movement caused by ground settlement. Couplings and reducing couplings allowing for 6° total angular deflection 3° total on the flange adaptors.
- ▶ A rigorous bolt torque test is completed to confirm that the bolt, end ring and adaptor body are capable of withstanding bolt over-tightening to 1.5 times maximum recommended torque.

# MaxiFit, MaxiFit Xtra & MaxiStep

## Product Design Benefits

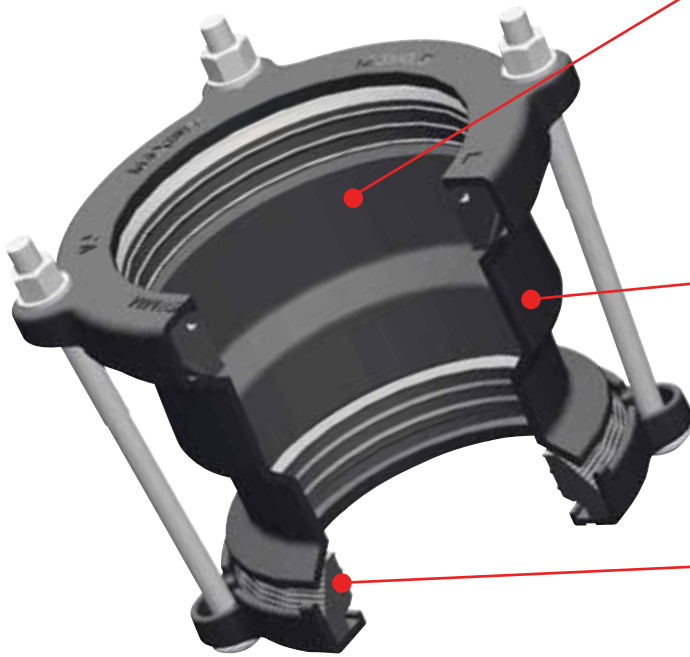

### Simple Installation

Available as standard and long sleeved versions, the MaxiFit Xtra simplifies the installation further, allowing for greater cutting tolerances and a greater pipe insertion depth - sealing beyond corrosion damaged pipe ends to create a safe and permanent repair.

### Excellent Repair Product

MaxiStep reducing couplings are designed to provide transitions between pipes of different nominal bores simplifying installations when repairing old pipe with new.

### Accommodates Pipe Movement

All models accommodate angularity between pipes which allows for normal pipeline movement due to ground settlement. Couplings and reducing couplings allow for 6° total angular deflection.

# MaxiDaptor

## Product Design Benefits

### Ultimate Flexibility

All cast flanges have multi drilling including; BS EN 1092-1, ISO 7005 1:1992, (PN10/16), BS10: 1962 (Table ADE), ANSI/AWWA.

### Exceptional Sealing Capabilities

Flanges have an extended sealing face.

### Accommodates Pipe Movement

All models accommodate angularity between pipes which allows for normal pipeline movement caused by to ground settlement. Flange adaptors have a total angular deflection of 3°.

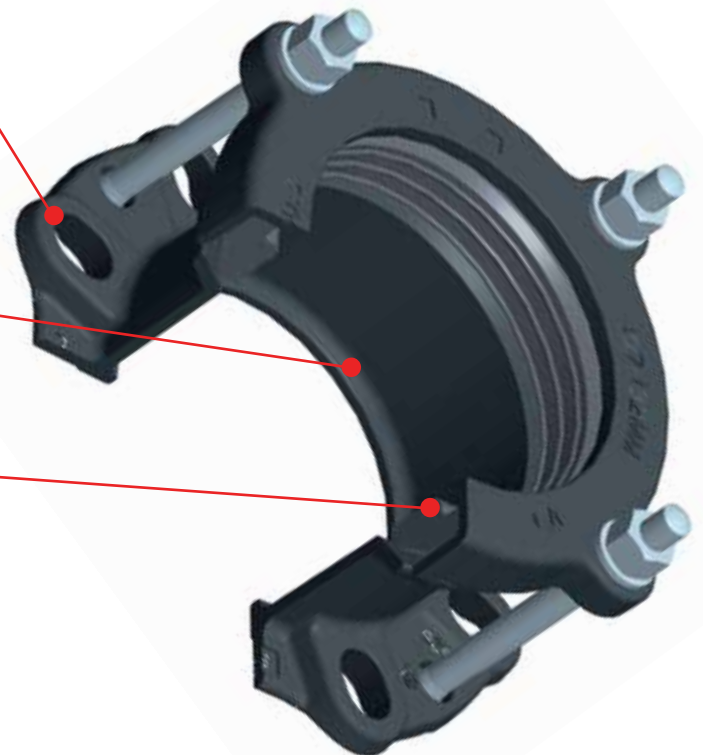

# MaxiFit & MaxiFit Xtra Couplings & End Caps

## Specifications

Working Pressure = 16bar (water)  
6bar (gas)

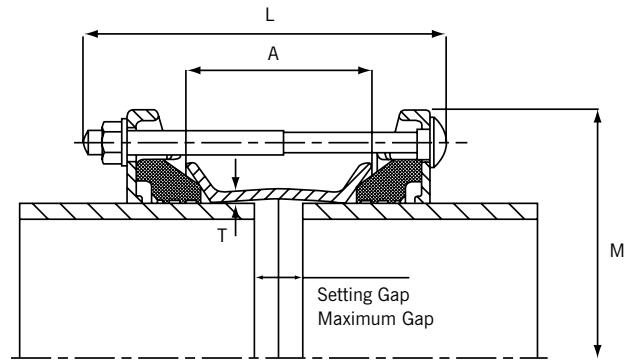

## Coupling

### Coupling - Standard Sleeve (MaxiFit)

Nominal Size (mm)	Size Range (mm)		Diameter (mm)	Overall Length (mm)		Sleeve Length x Thickness		Setting Gap (mm)		Bolts No.-Dia x Length	Gasket Mould No.	Weight (kg)	MaxiCap Available	Maximum Threaded Outlet	MaxiFit Plus Available
	Min	Max		M	L	(A) x (T)	Min	Max							
DN40	47.9	59.5	149.5	190.0	100.0 x 4.5	20.0	40.0	2-M12 x 180	1637	3.1					
DN50	57.0	74.0	154.5	190.0	95.0 x 4.5	20.0	40.0	4-M12 x 180	12392/1	3.0	✓	1"	✓		
DN65	63.0	85.0	173.5	190.0	95.0 x 4.5	20.0	40.0	4-M12 x 180	12392/2	3.6	✓	1"	✓		
DN80	85.0	107.0	195.5	190.0	95.0 x 4.5	20.0	40.0	4-M12 x 180	12392/3	4.1	✓	2"	✓		
DN100	107.0	132.0	224.5	190.0	95.0 x 4.5	20.0	40.0	4-M12 x 180	12392/4	5.0	✓	2"	✓		
DN125	132.0	158.0	254.5	190.0	95.0 x 5.0	20.0	40.0	4-M12 x 180	12392/6	6.1	✓	2"	✓		
DN150	158.0	184.0	280.5	190.0	95.0 x 5.0	20.0	40.0	4-M12 x 180	12392/7	7.0	✓	2"	✓		
DN175	189.0	212.0	306.5	230.0	130.0 x 5.0	25.0	50.0	4-M12 x 220	12392/9	9.4	✓	2"			
DN200	218.0	244.0	342.5	230.0	130.0 x 5.0	25.0	50.0	4-M12 x 220	12392/10	10.9	✓	2"			
DN225	243.0	269.0	367.5	230.0	130.0 x 5.0	25.0	50.0	6-M12 x 220	12392/11	12.4	✓	2"			
DN250	266.0	295.0	399.5	230.0	130.0 x 5.0	25.0	50.0	6-M12 x 220	12392/12	14.6	✓	2"			
DN300	315.0	349.0	462.5	230.0	130.0 x 5.0	25.0	50.0	8-M12 x 220	12392/14	19.4	✓	2"			

### Coupling - Long Sleeve (MaxiFit Xtra)

DN50	57.0	74.0	154.5	285.0	200.0 x 5.5	20.0	140.0	4-M12 x 275	12392/1	4.6	✓	1"			
DN65	63.0	85.0	173.5	285.0	190.0 x 5.5	20.0	130.0	4-M12 x 275	12392/2	5.2	✓	1"			
DN80	85.0	107.0	195.5	285.0	200.0 x 5.5	20.0	140.0	4-M12 x 275	12392/3	6.3	✓	2"			
DN100	107.0	132.0	224.5	285.0	190.0 x 5.5	20.0	130.0	4-M12 x 275	12392/4	7.2	✓	2"			
DN125	132.0	158.0	254.5	285.0	190.0 x 6.0	20.0	130.0	4-M12 x 275	12392/6	9.0	✓	2"			
DN150	158.0	184.0	280.5	285.0	190.0 x 6.0	20.0	130.0	4-M12 x 275	12392/7	10.3	✓	2"			
DN175	189.0	212.0	306.5	285.0	190.0 x 6.0	25.0	110.0	4-M12 x 275	12392/9	12.1	✓	2"			
DN200	218.0	244.0	342.5	285.0	190.0 x 6.0	25.0	110.0	4-M12 x 275	12392/10	14.1	✓	2"			
DN225	243.0	269.0	367.5	350.0	250.0 x 6.0	25.0	165.0	6-M12 x 340	12392/11	18.6	✓	2"			
DN250	266.0	295.0	399.5	350.0	250.0 x 6.0	25.0	165.0	6-M12 x 340	12392/12	21.4	✓	2"			
DN300	315.0	349.0	462.5	350.0	240.0 x 6.0	25.0	155.0	8-M12 x 340	12392/14	27.0	✓	2"			

## Materials & Relevant Standards

### End Ring and Adaptor Body/Centre Sleeve

Ductile Iron to BS EN 1563 Symbol EN GJS-450-10

### Gasket

EPDM compound Grade E to BS EN 681-1, Type WA, WC

Nitrile compound to Grade G BS EN 682, Type G

### Tee Bolts/Bolts

Steel to BS EN ISO 898-1 Property Class 4.8

### Bolt Torque/Spanner

Bolt torque 55-65Nm, Spanner size A/F 19mm

### Nuts

Steel to BS EN 4190 Grade 4

### Washers

Stainless Steel to BS 1449:Part 2 Grade 304S15 Standard

Every effort has been made to ensure that the information contained in this publication is accurate at the time of publishing. Crane Ltd assumes no responsibility or liability for typographical errors or omissions or for any misinterpretation of the information within the publication and reserves the right to change without notice.

# MaxiStep Reducing Couplings

## Specifications

Working Pressure = 16bar (water)  
6bar (gas)

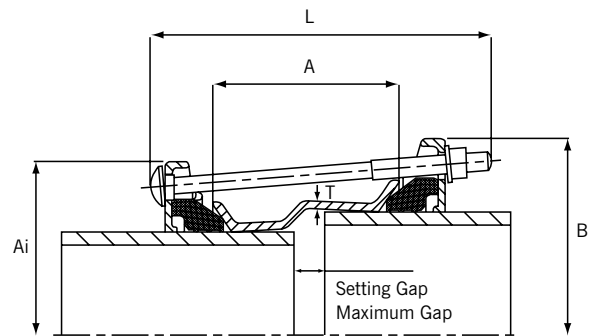

## Reducing Coupling

Nom Size	Size Range (mm)				Diameter (mm)		Overall Length (mm)	Sleeve Length x Thickness	Setting Gap (mm)		Bolts No.-Dia x Length	Gasket Mould No.		Weight (kg)
	Min	Max	Min	Max	Ai	B			Min	Max		Small End	Large End	
50/65	57.0	74.0	63.0	85.0	154.5	173.5	210.0	110.0 x 4.5	20.0	40.0	4-M12 x 200	12392/1	12392/2	3.5
50/80	57.0	74.0	85.0	107.0	154.5	195.5	210.0	110.0 x 4.5	20.0	40.0	4-M12 x 200	12392/1	12392/3	3.9
65/80	63.0	85.0	85.0	107.0	173.5	195.5	210.0	110.0 x 4.5	20.0	40.0	4-M12 x 200	12392/2	12392/3	4.2
80/100	85.0	107.0	107.0	132.0	195.5	224.5	210.0	110.0 x 4.5	20.0	40.0	4-M12 x 200	12392/3	12392/4	4.8
100/125	107.0	132.0	132.0	158.0	224.5	254.5	220.0	120.0 x 4.5	20.0	40.0	4-M12 x 210	12392/4	12392/6	6.2
125/150	132.0	158.0	158.0	184.0	254.5	280.5	220.0	120.0 x 5.0	20.0	40.0	4-M12 x 210	12392/6	12392/7	7.2
150/175	158.0	184.0	189.0	212.0	280.5	306.5	230.0	130.0 x 5.0	25.0	50.0	4-M12 x 220	12392/7	12392/9	8.8
175/200	189.0	212.0	218.0	244.0	306.5	342.5	230.0	130.0 x 5.0	25.0	50.0	4-M12 x 220	12392/9	12392/10	10.4
200/225	218.0	244.0	243.0	269.0	342.5	367.5	230.0	130.0 x 5.0	25.0	50.0	6-M12 x 220	12392/10	12392/11	12.2
225/250	243.0	269.0	266.0	295.0	367.5	399.5	230.0	130.0 x 5.0	25.0	50.0	6-M12 x 220	12392/11	12392/12	13.7

## Materials & Relevant Standards

### End Ring and Adaptor Body/Centre Sleeve

Ductile Iron to BS EN 1563 Symbol EN GJS-450-10

### Gasket

EPDM compound Grade E to BS EN 681-1, Type WA, WC

Nitrile compound to Grade G BS EN 682, Type G

### Tee Bolts/Bolts

Steel to BS EN ISO 898-1 Property Class 4.8

### Bolt Torque/Spanner

Bolt torque 55-65Nm, Spanner size A/F 19mm

### Nuts

Steel to BS EN 4190 Grade 4

### Washers

Stainless Steel to BS 1449:Part 2 Grade 304S15 Standard

Every effort has been made to ensure that the information contained in this publication is accurate at the time of publishing. Crane Ltd assumes no responsibility or liability for typographical errors or omissions or for any misinterpretation of the information within the publication and reserves the right to change without notice.



# MaxiDaptor Flange Adaptors

## Specifications

Working Pressure = 16bar (water)  
6bar (gas)

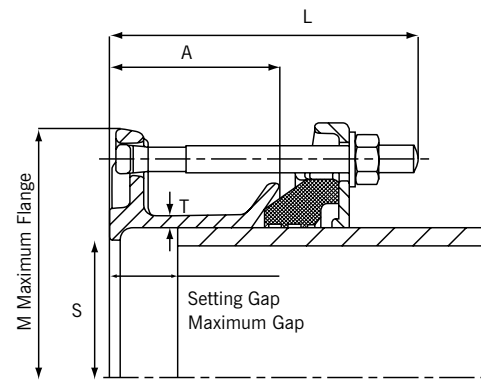

## Flange Adaptor

Nom Size	Size Range (mm)		Diameter (mm)	Bores (mm)	Overall Length (mm)	Sleeve Length x Thickness	Flange Drilling	Setting Gap (mm)		Bolts No.-Dia x Length	Gasket Mould No.	Weight (kg)	MaxiFit Plus Available
	Min	Max	M	S	L	(A) x (T)		Min	Max				
50	57.0	74.0	163.4	59.0	124.0	75.0 x 5.0	50 PN10:16, 2.5" BS10 Table ADE, 2" ANSI125	20.0	40.0	4-M12 x 115	12392/1	2.7	
65	63.0	85.0	196.9	75.0	124.0	75.0 x 5.0	60 PN10:16, 65 PN10:16, 80 PN10:16, 3" BS10 Table ADE, 2.5" ANSI125, 3" ANSI125 80 AS2129 CD, 80 AS4087 16	20.0	40.0	4-M12 x 115	12392/2	3.5	✓
80	85.0	107.0	202.5	101.0	124.0	75.0 x 5.0	80 PN10:16, 3" ANSI125, 3.5" BS10 Table AD, 3.5" BS10 Table E	20.0	40.0	4-M12 x 115	12392/3	3.7	✓
100	107.0	132.0	228.0	121.0	134.0	75.0 x 5.0	100 PN 10:16, 4" BS10 Table AD, 4" BS10 Table E, 4" AWWA C207 D, 100 AS2129 CD, 100 AS4087 16	20.0	40.0	4-M12 x 125	12392/4	4.4	✓
125	132.0	158.0	281.5	150.0	134.0	75.0 x 5.0	125 PN10:16, 150 PN10:16 5" BS10 Table A, 5" BS10 Table DE, 6" BS10 Table A, 6" BS10 Table D, 6" BS10 Table E, 6" AWWA C207 D, 125 AS2129 CD, 150 AS2129 CD, 125 AS4087 16, 150 AS4087 16	20.0	40.0	4-M12 x 125	12392/6	5.6	
150	158.0	184.0	281.2	173.0	134.0	75.0 x 5.0	150 PN10:16, 6" BS10 Table A, 6" BS10 Table D, 6" AWWA C207 D, 150 AS4087 16, 150 AS2129 CD,	20.0	40.0	4-M12 x 125	12392/7	6.0	
175	189.0	212.0	336.5	202.0	133.0	75.0 x 5.0	200 PN10:16, 8" BS10 Table AD, 8" AWWA C207 D, 200 AS2129 CD, 200 AS4087 16	25.0	40.0	4-M12 x 125	12392/9	8.3	
200	218.0	244.0	337.8	225.0	134.0	75.0 x 5.0	200 PN10:16, 8" BS10 Table AD, 8" AWWA C207 D, 200 AS2129 CD	25.0	40.0	4-M12 x 125	12392/10	8.3	
225	243.0	269.0	401.5	252.0	144.0	85.0 x 5.0	250 PN10:16, 250 AS4087 16	25.0	50.0	6-M12 x 135	12392/11	10.9	
250	266.0	295.0	402.1	277.0	146.0	85.0 x 5.0	250 PN10:16, 250 AS4087 16	25.0	50.0	6-M12 x 135	12392/12	11.4	
300	315.0	349.0	457.8	329.0	155.0	100.0 x 5.0	300 PN10:16, 12" BS10 Table D, 300 AS2129 CD	25.0	60.0	6-M12 x 145	12392/14	14.8	

## Materials & Relevant Standards

### End Ring and Adaptor Body/Centre Sleeve

Ductile Iron to BS EN 1563 Symbol EN GJS-450-10

### Gasket

EPDM compound Grade E to BS EN 681-1, Type WA, WC

Nitrile compound to Grade G BS EN 682, Type G

### Tee Bolts/Bolts

Steel to BS EN ISO 898-1 Property Class 4.8

### Bolt Torque/Spanner

Bolt torque 55-65Nm, Spanner size A/F 19mm

### Nuts

Steel to BS EN 4190 Grade 4

### Washers

Stainless Steel to BS 1449:Part 2 Grade 304S15 Standard

Every effort has been made to ensure that the information contained in this publication is accurate at the time of publishing. Crane Ltd assumes no responsibility or liability for typographical errors or omissions or for any misinterpretation of the information within the publication and reserves the right to change without notice.

United Kingdom - Lancashire

# Hodder Aqueduct

MaxiStep Reducing Coupling - DN700

## Project

Relining & Cleaning Scheme -  
The 28 mile Hodder Aqueduct  
was originally constructed in  
1925 by Flyde Water Board to  
supply water to Blackpool from  
Stocks reservoir.

## Client

United Utilities



# MaxiFit Large Diameter

## Product Design Benefits

### Simple to Fit

All Large Diameter MaxiFit, MaxiStep & MaxiDaptor products (DN350 – DN700) have a long sleeve length as standard; this is a major benefit to the installer, allowing for greater cutting tolerances and a greater pipe insertion depth sealing beyond corrosion damaged pipe ends to create a safe and permanent repair.

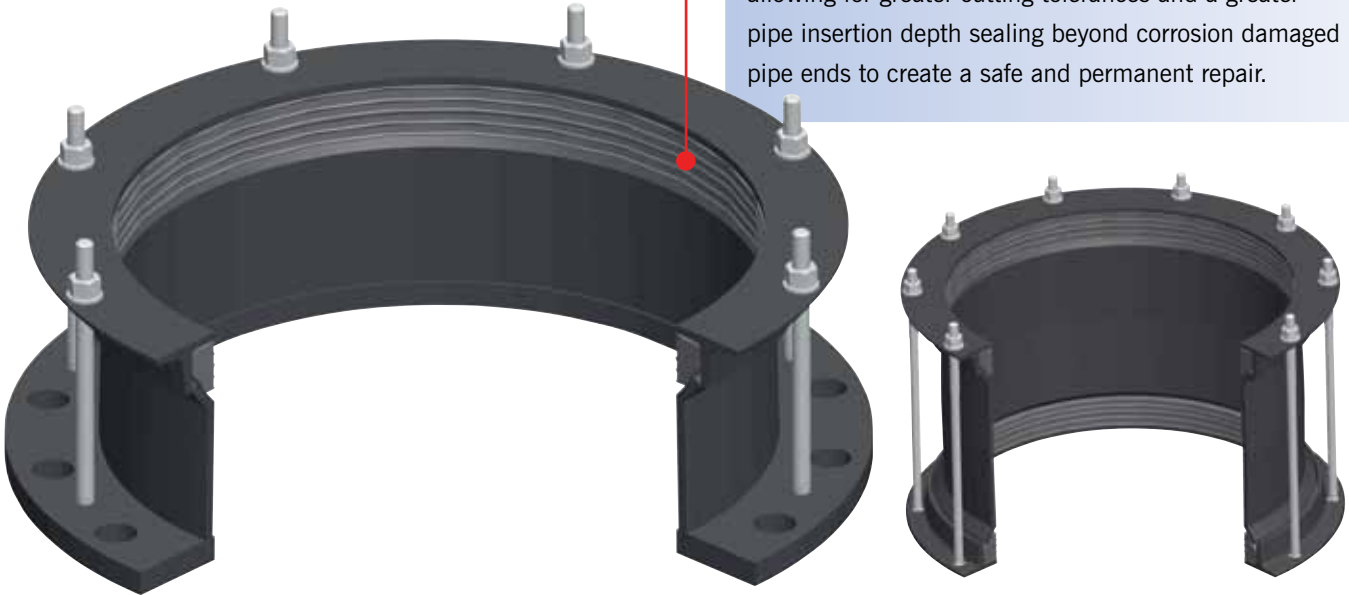

# MaxiCap & MaxiThread End Cap

## Product Design Benefits

Designed for testing and blanking off a pipe end, although the assembly must have suitable external support to prevent movement under pressure. Alternatively, the MaxiCap provides a connection between a plain ended and a threaded pipe.

### Dual Purpose

The MaxiCap end cap fits inside the end ring to the MaxiFit and can be drilled and tapped to form an outlet (up to 2" depending on size).

### Enables Testing On-Site

Converts product to cap end for testing and blanking off (Although the assembly must have suitable external support to prevent movement under pressure).

### Connects to Threaded Pipe

The MaxiThread threaded end cap is designed to provide a connection between plain-ended and threaded pipe. Outlets are available with 1", 1.25" and 1.5" BSP threads. It is constructed with a MaxiFit coupling body with one standard end ring and one threaded end ring.

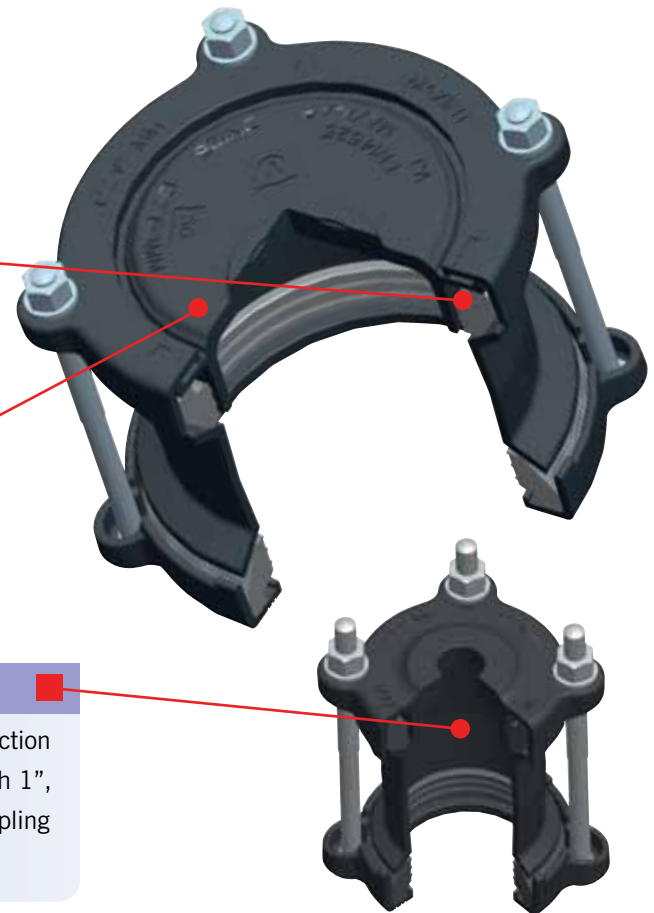

# MaxiFit Large Diameter Couplings

## Specifications

1 = Sleeve 2 = End Ring  
3 = Gasket 4 = Bolts, Nuts & Washer

Working Pressure = 16bar (water)  
6bar (gas)

## Coupling

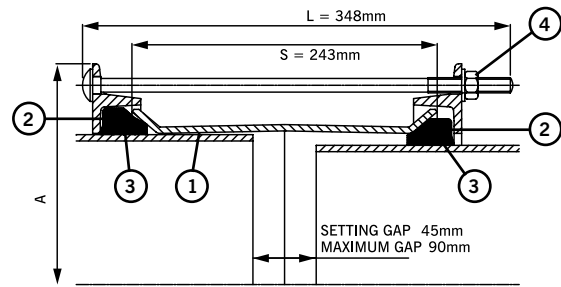

OD Range		Dimensions	Gasket Mould No.	Bolts No.-Dia x Length	Weight (kg)
Min (mm)	Max (mm)	End Ring Diameter A (mm)			
351.0	368.0	478.0	6002	8-M12 x 340	30.1
374.5	391.5	501.5	1659	8-M12 x 340	31.9
386.0	403.0	513.0	6035	8-M12 x 340	32.6
394.3	411.3	521.5	1766	8-M12 x 340	33.2
404.8	421.8	532.0	1767	8-M12 x 340	34.0
412.0	429.0	539.0	6023	10-M12 x 340	35.1
418.2	435.2	545.0	1784	8-M12 x 340	34.9
425.0	442.0	552.0	1662	8-M12 x 340	35.5
434.5	451.5	561.5	1768	10-M12 x 340	37.0
439.0	456.0	566.0	6036	10-M12 x 340	37.3
447.2	464.2	574.0	1769	10-M12 x 340	37.9
455.0	472.0	582.0	6003	10-M12 x 340	38.5
467.0	484.0	594.0	6073	10-M12 x 340	39.3
476.0	493.0	603.0	1770	10-M12 x 340	39.9
487.0	504.3	614.5	1771	10-M12 x 340	40.7
492.0	509.0	619.0	6037	10-M12 x 340	41.1
501.9	518.9	629.0	1772	10-M12 x 340	41.8
510.0	527.0	637.0	6004	10-M12 x 340	42.3
515.0	532.0	642.0	6024	10-M12 x 340	42.8
527.0	544.0	654.0	1773	12-M12 x 340	44.1
540.1	557.1	667.0	1774	10-M12 x 340	44.5
546.0	563.0	673.0	6038	12-M12 x 340	45.5
555.3	572.3	682.5	1775	12-M12 x 340	46.1
565.0	582.0	692.0	1776	12-M12 x 340	46.8
582.2	599.2	709.0	1777	12-M12 x 340	48.0
593.0	610.0	720.0	6021	12-M12 x 340	48.8
601.0	618.0	728.0	6020	12-M12 x 340	49.4
613.0	630.0	740.0	6019	12-M12 x 340	50.3
618.0	635.0	745.0	6025	12-M12 x 340	50.6
630.0	647.0	757.0	1778	14-M12 x 340	52.0
645.2	662.2	772.0	1779	14-M12 x 340	53.0
654.0	671.0	781.0	6039	14-M12 x 340	53.8
662.0	679.0	789.0	1780	14-M12 x 340	54.3
675.0	692.0	802.0	6005	14-M12 x 340	55.2
689.0	706.0	816.0	10511/49	14-M12 x 340	56.3
695.0	712.0	822.0	6063	14-M12 x 340	56.7
710.0	727.0	837.0	6075	14-M12 x 340	57.7

## Materials & Relevant Standards

### Sleeve

Rolled Steel to BS EN 10025-2 Grade S275

### End Ring

Rolled Steel to BS EN 10025-2 Grade S275

### Gasket

EPDM Grade "E" to BS EN 681-1 Type WA WRAS Listed

### Bolt Torque / Spanner

**Bolt torque** - 55-65Nm / **Spanner size** - A/F 19mm

### Bolts, Nuts & Washer

**Bolts** - Steel to BS EN ISO 898-1 Property Class 4.8

**Nuts** - Steel to BS EN 4190 Grade 4

**Washer** - Stainless Steel to BS 1449:Part 2 Grade 304 S15

### Coating

**Sleeve & End Ring** = Rilsan Nylon 11 to WIS 4-52-01 Part 1

**Bolts & Nuts** = Sheraplex to WIS 4-52-03

Every effort has been made to ensure that the information contained in this publication is accurate at the time of publishing. Crane Ltd assumes no responsibility or liability for typographical errors or omissions or for any misinterpretation of the information within the publication and reserves the right to change without notice.

# MaxiStep Large Diameter Expanded Sleeve Stepped Couplings

## Specifications

1 = Sleeve 2 = End Ring  
3 = Gasket 4 = Bolts, Nuts & Washer

Working Pressure = 16bar (water)  
6bar (gas)

## Expanded Sleeve Stepped Coupling

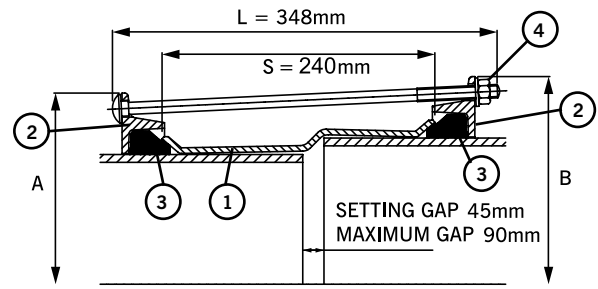

OD Range				Gasket Mould No.		Bolts No. - Dia x Length	Dimensions		Weight (kg)
Small End		Large End		Small End	Large End		End Ring Diameter		
Min (mm)	Max (mm)	Min (mm)	Max (mm)				Small End A (mm)	Large End B (mm)	
374.5	391.5	394.3	411.3	1659	1766	8-M12 x 340	501.5	521.5	32.1
374.5	391.5	404.8	421.8	1659	1767	8-M12 x 340	501.5	532.0	32.4
374.5	391.5	418.2	435.2	1659	1784	10-M12 x 340	501.5	545.0	33.1
386.0	403.0	412.0	429.0	6035	6023	10-M12 x 340	513.0	539.0	33.6
394.3	411.3	418.2	435.2	1766	1784	10-M12 x 340	521.5	545.0	34.1
404.8	421.8	418.2	435.2	1767	1784	10-M12 x 340	532.0	545.0	34.7
404.8	421.8	425.0	442.0	1767	1662	10-M12 x 340	532.0	552.0	34.8
425.0	442.0	434.5	451.4	1662	1768	10-M12 x 340	552.0	561.5	36.3
425.0	442.0	447.2	464.2	1662	1769	10-M12 x 340	552.0	574.0	36.5
425.0	442.0	455.0	472.0	1662	6003	10-M12 x 340	552.0	582.0	36.6
439.0	456.0	467.0	484.0	6036	6073	10-M12 x 340	566.0	594.0	37.8
455.0	472.0	467.0	484.0	6003	6073	10-M12 x 340	582.0	594.0	38.7
476.0	493.0	487.3	504.3	1770	1771	10-M12 x 340	603.0	614.5	40.1
476.0	493.0	501.9	518.9	1770	1772	10-M12 x 340	603.0	629.0	40.4
476.0	493.0	510.0	527.0	1770	6004	10-M12 x 340	603.0	637.0	40.5
492.0	509.0	510.0	527.0	6037	6004	10-M12 x 340	619.0	637.0	41.4
492.0	509.0	527.0	544.0	6037	1773	12-M12 x 340	619.0	654.0	42.2
501.9	518.9	527.0	544.0	1772	1773	12-M12 x 340	629.0	654.0	42.8
510.0	527.0	527.0	544.0	6004	1773	12-M12 x 340	637.0	654.0	43.1
527.0	544.0	540.1	557.1	1773	1774	12-M12 x 340	654.0	667.0	44.3
527.0	544.0	555.3	572.3	1773	1775	12-M12 x 340	654.0	682.5	44.6
527.0	544.0	566.5	583.5	1773	1776	12-M12 x 340	654.0	693.5	44.8
527.0	544.0	573.0	590.0	1773	6129	12-M12 x 340	654.0	700.0	44.9
527.0	544.0	582.2	599.2	1773	1777	12-M12 x 340	654.0	709.0	45.1
546.0	563.0	590.5	607.5	6038	6074	12-M12 x 340	673.0	717.5	46.3
598.0	615.0	630.0	647.0	6130	1778	14-M12 x 340	725.0	757.0	50.3
601.0	618.0	630.0	647.0	6020	1778	14-M12 x 340	728.0	757.0	50.4
601.0	618.0	645.2	662.2	6020	1779	14-M12 x 340	728.0	772.0	50.7
618.0	635.0	630.0	647.0	6025	1778	14-M12 x 340	745.0	757.0	51.3
630.0	647.0	645.2	662.2	1778	1779	14-M12 x 340	757.0	772.0	52.3
630.0	647.0	654.0	671.0	1778	6039	14-M12 x 340	757.0	781.0	52.4
630.0	647.0	662.0	679.0	1778	1780	14-M12 x 340	757.0	789.0	52.6
630.0	647.0	675.0	692.0	1778	6005	14-M12 x 340	757.0	802.0	52.8
654.0	671.0	710.0	727.0	6039	6075	14-M12 x 340	781.0	837.0	54.7
733.0	750.0	741.0	758.0	10511/46	10511/51	16-M12 x 340	860.0	868.0	60.1

## Materials & Relevant Standards

### Make Up Ring Sleeve

Mild Steel to BS EN 10025-2 Grade S275  
Rolled Steel to BS EN 10025-2 Grade S275

### End Ring

Rolled Steel to BS EN 10025-2 Grade S275

### Gasket

EPDM Grade "E" to BS EN 681-1 Type WA WRAS Listed

### Bolt Torque / Spanner

Bolt torque - 55-65Nm / Spanner size - A/F 19mm

### Bolts, Nuts & Washer

Bolts - Steel to BS EN ISO 898-1 Property Class 4.8

Nuts - Steel to BS EN 4190 Grade 4

Washer - Stainless Steel to BS 1449:Part 2 Grade 304 S15

### Coating

Sleeve & End Ring = Rilsan Nylon 11 to WIS 4-52-01 Part 1

Bolts & Nuts = Sheraplex to WIS 4-52-03

Every effort has been made to ensure that the information contained in this publication is accurate at the time of publishing. Crane Ltd assumes no responsibility or liability for typographical errors or omissions or for any misinterpretation of the information within the publication and reserves the right to change without notice.

# MaxiStep Large Diameter Make Up Ring Stepped Couplings

## Specifications

Working Pressure = 16bar (water)  
6bar (gas)

- 1 = Make Up Ring Sleeve
- 2 = End Ring
- 3 = Gasket
- 4 = Stud, Nut & Washer

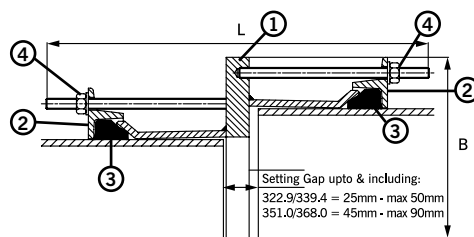

## Make Up Ring Stepped Couplings

OD Range				Gasket Mould		Studs		Dimensions		Weight (Kg)
Small End		Large End		Small End	Large End	Small End No.-Dia x Length	Large End No.-Dia x Length	Overall Diameter B (mm)	Overall Length L (mm)	
Min (mm)	Max (mm)	Min (mm)	Max (mm)							
315.0	332.0	351.0	368.0	1738	6002	8-M12 x 125	8-M12 x 205	478	326	39.3
315.0	332.0	367.0	384.0	1738	6097	8-M12 x 125	8-M12 x 190	494	316	45.6
315.0	332.0	374.5	391.5	1738	1659	8-M12 x 125	8-M12 x 205	502	335	47.3
315.0	332.0	404.8	421.8	1738	1767	8-M12 x 125	8-M12 x 205	532	335	53.1
315.0	332.0	418.2	435.2	1738	1784	8-M12 x 125	10-M12 x 205	545	337	58.6
322.9	339.4	374.5	391.5	1657	1659	8-M12 x 125	8-M12 x 205	502	331	46.7
351.0	368.0	367.0	384.0	6002	6097	8-M12 x 205	8-M12 x 205	494	410	43.7
351.0	368.0	374.5	391.5	6002	1659	8-M12 x 205	8-M12 x 205	502	410	44.9
351.0	368.0	394.3	411.3	6002	1766	8-M12 x 205	8-M12 x 205	522	410	48.1
351.0	368.0	527.0	544.0	6002	1773	8-M12 x 205	12-M12 x 205	654	423	96.0
367.0	384.0	374.5	391.5	6097	1659	8-M12 x 205	8-M12 x 205	502	410	44.2
374.5	391.5	412.0	429.0	1659	6023	8-M12 x 205	10-M12 x 205	539	410	54.0
374.5	391.5	425.0	442.0	1659	1662	8-M12 x 205	10-M12 x 205	552	411	56.6
394.3	411.3	404.8	421.8	1766	1767	8-M12 x 205	8-M12 x 205	532	410	47.1
394.3	411.3	425.0	442.0	1766	1662	8-M12 x 205	10-M12 x 205	552	410	50.8
394.3	411.3	447.2	464.2	1766	1769	8-M12 x 205	10-M12 x 205	574	415	59.6
404.8	421.8	434.5	451.5	1767	1768	8-M12 x 205	10-M12 x 205	562	420	51.9
404.8	421.8	439.0	456.0	1767	6036	8-M12 x 205	10-M12 x 205	566	415	56.9
404.8	421.8	447.2	464.2	1767	1769	8-M12 x 205	10-M12 x 205	574	415	58.6
404.8	421.8	467.0	484.0	1767	6073	8-M12 x 205	10-M12 x 205	594	415	62.8
412.0	429.0	425.0	442.0	6023	1662	10-M12 x 205	10-M12 x 205	552	410	50.0
418.2	435.2	434.5	451.5	1784	1768	10-M12 x 205	10-M12 x 205	562	411	51.3
418.2	435.2	455.0	472.0	1784	6003	10-M12 x 205	10-M12 x 205	582	415	59.4
425.0	442.0	476.0	493.0	1662	1770	10-M12 x 205	10-M12 x 205	603	411	63.2
425.0	442.0	487.0	504.0	1662	1771	10-M12 x 205	10-M12 x 205	615	411	65.7
425.0	442.0	527.0	544.0	1662	1773	10-M12 x 205	12-M12 x 205	654	392	81.6
425.0	442.0	555.3	572.3	1662	1775	10-M12 x 205	12-M12 x 205	683	421	92.3
425.0	442.0	565.0	582.0	1662	1776	10-M12 x 205	12-M12 x 205	692	422	95.9
439.0	456.0	527.0	544.0	6036	1773	10-M12 x 205	12-M12 x 205	654	419	78.7
447.2	464.2	476.0	493.0	1769	1770	10-M12 x 205	10-M12 x 205	603	410	56.7
447.2	464.2	487.0	504.3	1769	1771	10-M12 x 205	10-M12 x 205	615	415	63.7
447.2	464.4	455.0	472.0	1769	6003	10-M12 x 205	10-M12 x 205	582	411	52.9
476.0	493.0	527.0	544.0	1770	1773	10-M12 x 205	12-M12 x 205	654	415	69.7
492.0	509.0	555.3	572.3	6037	1775	10-M12 x 205	12-M12 x 205	683	416	76.1
501.9	518.9	540.1	557.1	1772	1774	10-M12 x 205	12-M12 x 205	667	411	69.7
527.0	544.0	598.0	615.0	1773	6130	12-M12 x 205	12-M12 x 205	725	413	83.9
527.0	544.0	601.0	618.0	1773	6020	12-M12 x 205	12-M12 x 205	728	417	85.2
527.0	544.0	630.0	647.0	1773	1778	12-M12 x 205	14-M12 x 205	757	422	101.0
527.0	544.0	645.2	662.2	1773	1779	12-M12 x 205	14-M12 x 205	772	423	108.0
527.0	544.0	675.0	692.0	1773	6005	12-M12 x 205	14-M12 x 205	802	412	122.0
565.0	582.0	582.2	599.2	1776	1777	12-M12 x 205	12-M12 x 205	709	401	67.0
565.0	582.0	601.0	618.0	1776	6020	12-M12 x 205	12-M12 x 205	728	415	76.5
566.5	583.5	601.0	618.0	1776	6020	12-M12 x 205	12-M12 x 205	728	415	76.5
582.2	599.2	601.0	618.0	1777	6020	12-M12 x 205	12-M12 x 205	728	410	69.1
582.2	599.2	630.0	647.0	1777	1778	12-M12 x 205	14-M12 x 205	757	421	83.2
598.0	615.0	630.0	647.0	6130	1778	14-M12 x 205	14-M12 x 205	757	411	80.0
601.0	618.0	630.0	647.0	6020	1778	14-M12 x 205	14-M12 x 205	757	411	79.5
601.0	618.0	675.0	692.0	6020	6005	14-M12 x 205	14-M12 x 205	802	419	99.0
630.0	647.0	689.0	706.0	1778	10511/49	14-M12 x 205	14-M12 x 205	816	418	94.9
630.0	647.0	710.0	727.0	1778	6075	14-M12 x 205	14-M12 x 205	837	420	106.0

## Materials & Relevant Standards

### Make Up Ring Sleeve

Mild Steel to BS EN 10025-2 Grade S275  
Rolled Steel to BS EN 10025-2 Grade S275

### End Ring

Rolled Steel to BS EN 10025-2 Grade S275

### Gasket

EPDM Grade "E" to BS EN 681-1 Type WA WRAS Listed

### Bolt Torque / Spanner

Bolt torque - 55-65Nm / Spanner size - A/F 19mm

### Bolts, Nuts & Washer

Bolts - Steel to BS EN ISO 898-1 Property Class 4.8

Nuts - Steel to BS EN 4190 Grade 4

Washer - Stainless Steel to BS 1449:Part 2 Grade 304 S15

### Coating

Sleeve & End Ring = Rilsan Nylon 11 to WIS 4-52-01 Part 1

Bolts & Nuts = Sheraplex to WIS 4-52-03

Every effort has been made to ensure that the information contained in this publication is accurate at the time of publishing. Crane Ltd assumes no responsibility or liability for typographical errors or omissions or for any misinterpretation of the information within the publication and reserves the right to change without notice.

# MaxiDaptor Large Diameter Flange Adaptor PN10

## Specifications

- 1 = Make Up Ring Sleeve
- 2 = End Ring
- 3 = Gasket
- 4 = Stud, Nut & Washer

Working Pressure = 16bar (water)  
6bar (gas)

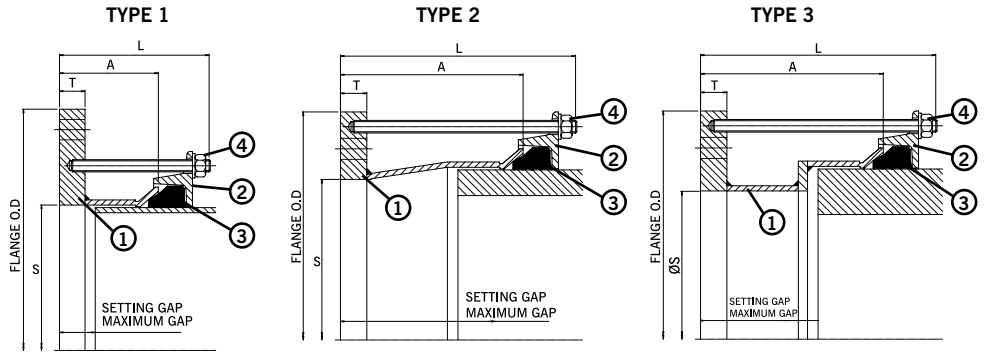

## Flange Adaptor PN10

OD Range		Flange Details						Type	Sleeve Length A (mm)	Overall Length L (mm)	Gasket Mould No.	Studs No.-Dia x Length	Setting Gap		Weight (kg)
Min (mm)	Max (mm)	Nom.	Drilling	Flange Diameter OD (mm)	Flange Bore S (mm)	Flange Thickness T (mm)	Min (mm)						Max (mm)		
351.0	368.0	300	PN10	478.0	300.0	18	3	205	298	6002	6-M12 x 290	130	153	36.6	
351.0	368.0	350	PN10	505.0	350.0	18	1	120	218	6002	8-M12 x 205	45	68	27.4	
351.0	368.0	350	PN10	505.0	370.0	18	1	120	218	6002	8-M12 x 205	45	68	28.9	
367.0	384.0	300	PN10	494.0	300.0	18	3	235	313	6097	6-M12 x 305	160	183	41.4	
367.0	384.0	350	PN10	505.0	350.0	18	1	120	213	6097	8-M12 x 205	45	68	29.5	
374.5	391.5	300	PN10	501.0	300.0	18	3	205	298	1659	6-M12 x 290	130	153	41.2	
374.5	391.5	350	PN10	505.0	350.0	18	1	120	213	1659	8-M12 x 205	45	68	29.8	
374.5	391.5	350	PN10	505.0	393.5	18	1	120	218	1659	8-M12 x 205	45	68	26.2	
374.5	391.5	400	PN10	565.0	393.5	25	1	120	218	1659	8-M12 x 205	45	68	39.4	
394.3	411.3	350	PN10	522.0	350.0	18	2	205	303	1766	8-M12 x 290	130	153	37.4	
394.3	411.3	350	PN10	505.0	397.5	18	2	205	303	1766	8-M12 x 290	130	153	33.5	
394.3	411.3	400	PN10	565.0	400.0	25	1	120	220	1766	8-M12 x 205	45	68	39.3	
394.3	411.3	400	PN10	565.0	413.5	25	1	120	220	1766	8-M12 x 205	45	68	37.6	
404.8	421.8	350	PN10	532.0	350.0	18	3	235	313	1767	8-M12 x 305	160	183	44.3	
404.8	421.8	400	PN10	565.0	400.0	18	1	120	213	1767	8-M12 x 205	45	68	33.4	
404.8	421.8	400	PN10	565.0	424.0	18	1	120	218	1767	8-M12 x 205	45	68	31.2	
418.2	435.2	400	PN10	565.0	400.0	18	1	120	213	1784	8-M12 x 205	45	68	33.8	
418.2	435.2	400	PN10	565.0	437.0	18	1	120	218	1784	8-M12 x 205	45	68	30.4	
425.0	442.0	350	PN10	552.0	350.0	18	3	235	313	1662	8-M12 x 305	160	183	48.5	
425.0	442.0	400	PN10	565.0	400.0	18	1	120	218	1662	8-M12 x 205	45	68	34.1	
425.0	442.0	400	PN10	565.0	444.0	18	1	120	218	1662	8-M12 x 205	45	68	30.0	
434.4	451.4	400	PN10	565.0	400.0	18	2	205	298	1768	8-M12 x 290	130	153	40.4	
434.4	451.4	400	PN10	565.0	448.0	18	2	205	298	1768	8-M12 x 290	130	153	35.9	
447.2	464.2	400	PN10	575.0	400.0	18	2	205	298	1769	8-M12 x 290	130	153	41.9	
447.2	464.2	400	PN10	575.0	448.0	18	2	205	298	1769	8-M12 x 290	130	153	37.4	
455.0	472.0	400	PN10	582.0	400.0	18	3	240	333	6003	8-M12 x 325	165	188	48.7	
455.0	472.0	450	PN10	615.0	450.0	23	1	120	213	6003	10-M12 x 205	45	68	42.0	
455.0	472.0	450	PN10	615.0	474.0	23	1	120	218	6003	10-M12 x 205	45	68	38.9	
467.0	484.0	400	PN10	594.0	400.0	23	3	205	303	6073	8-M12 x 290	130	153	54.7	
467.0	484.0	450	PN10	615.0	450.0	23	1	120	218	6073	10-M12 x 205	45	68	42.4	
476.0	493.0	400	PN10	603.0	400.0	23	3	240	338	1770	8-M12 x 325	170	193	60.6	
476.0	493.0	450	PN10	615.0	450.0	23	1	120	218	1770	10-M12 x 205	45	68	42.7	
476.0	493.0	450	PN10	615.0	495.0	23	1	120	218	1770	10-M12 x 205	45	68	36.7	
476.0	493.0	500	PN10	670.0	495.0	25	1	120	218	1770	10-M12 x 205	45	68	49.0	
487.3	504.3	400	PN10	615.0	400.0	23	3	245	338	1771	8-M12 x 325	170	193	63.8	
487.3	504.3	450	PN10	615.0	450.0	23	2	205	303	1771	10-M12 x 290	130	153	49.8	
487.3	504.3	450	PN10	615.0	499.0	23	2	205	303	1771	10-M12 x 290	130	153	43.2	

## Materials & Relevant Standards

### Flange Adaptor Body

Mild Steel to BS EN 10025-2 Grade S275

### End Ring

Rolled Steel to BS EN 10025-2 Grade S275

### Gasket

EPDM Grade "E" to BS EN 681-1 Type WA WRAS Listed

### Bolt Torque / Spanner

Bolt torque - 55-65Nm / Spanner size - A/F 19mm

### Studs, Nuts & Washer

Studs - Steel to BS EN ISO 898-1 Property Class 4.8

Nuts - Steel to BS EN 4190 Grade 4

Washer - Stainless Steel to BS 1449:Part 2 Grade 304 S15

### Coating

Flange Adaptor Body & End Ring = Rilsan Nylon 11 to WIS 4-52-01 Part 1

Bolts & Nuts = Sheraplex to WIS 4-52-03

Every effort has been made to ensure that the information contained in this publication is accurate at the time of publishing. Crane Ltd assumes no responsibility or liability for typographical errors or omissions or for any misinterpretation of the information within the publication and reserves the right to change without notice.

# MaxiDaptor Large Diameter Flange Adaptor PN10

## Specifications

- 1 = Adaptor Body
- 2 = End Ring
- 3 = Gasket
- 4 = Stud, Nut & Washer

Working Pressure = 16bar (water)  
6bar (gas)

## Flange Adaptor PN10

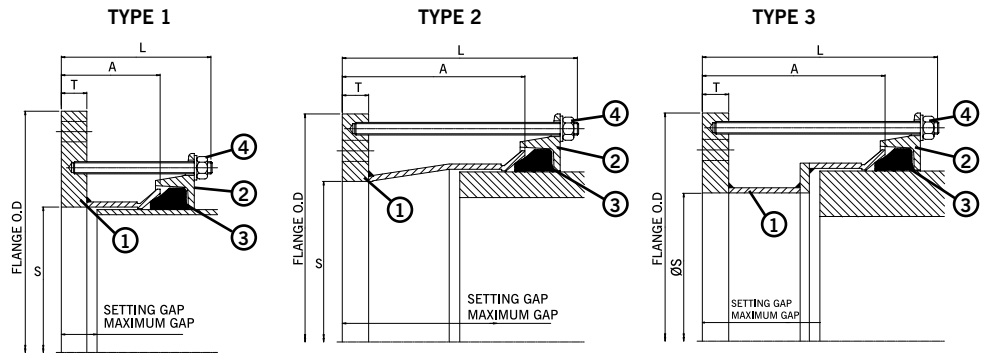

OD Range		Flange Details									Gasket Mould No.	Studs No.-Dia x Length	Setting Gap		Weight (kg)
Min (mm)	Max (mm)	Nom.	Drilling	Flange Diameter OD (mm)	Flange Bore S (mm)	Flange Thickness T (mm)	Type	Sleeve Length A (mm)	Overall Length L (mm)	Min (mm)			Max (mm)		
487.3	504.3	500	PN10	670.0	500.0	23	1	120	218	1771	10-M12 x 205	45	68	46.4	
492.0	509.0	500	PN10	670.0	511.0	23	1	120	218	6037	10-M12 x 205	45	68	45.0	
501.9	518.9	450	PN10	630.0	450.0	23	2	205	303	1772	10-M12 x 290	130	153	52.3	
501.9	518.9	450	PN10	615.0	485.5	23	2	205	303	1772	10-M12 x 290	130	153	47.6	
501.9	518.9	500	PN10	670.0	500.0	23	1	120	218	1772	10-M12 x 205	45	68	47.0	
501.9	518.9	500	PN10	670.0	521.0	23	1	120	218	1772	10-M12 x 205	45	68	43.9	
510.0	527.0	450	PN10	637.0	450.0	23	2	205	303	6004	10-M12 x 290	130	153	53.9	
510.0	527.0	450	PN10	637.0	494.0	23	2	205	303	6004	10-M12 x 290	130	153	48.0	
510.0	527.0	500	PN10	670.0	500.0	23	1	120	220	6004	10-M12 x 205	45	68	47.2	
527.0	544.0	500	PN10	670.0	500.0	23	1	120	218	1773	10-M12 x 205	45	68	47.8	
527.0	544.0	500	PN10	670.0	546.0	23	1	120	218	1773	10-M12 x 205	45	68	47.1	
540.1	557.1	450	PN10	667.0	450.0	23	3	250	338	1774	10-M12 x 325	175	198	71.2	
540.1	557.1	500	PN10	670.0	500.0	23	2	205	303	1774	10-M12 x 290	130	153	55.0	
540.1	557.1	500	PN10	670.0	550.0	23	2	205	303	1774	10-M12 x 290	130	153	47.6	
555.3	572.3	500	PN10	684.0	500.0	23	2	205	303	1775	10-M12 x 290	130	153	58.2	
555.3	572.3	500	PN10	684.0	550.0	23	2	205	303	1775	10-M12 x 290	130	153	50.8	
566.5	583.5	500	PN10	694.0	500.0	23	2	205	303	1776	10-M12 x 290	130	153	60.5	
566.5	583.5	500	PN10	694.0	550.0	23	2	205	303	1776	10-M12 x 290	130	153	53.1	
582.2	599.2	500	PN10	709.0	500.0	23	3	205	303	1777	10-M12 x 290	130	153	72.6	
582.2	599.2	500	PN10	670.0	540.0	23	3	205	303	1777	10-M12 x 290	130	153	64.5	
582.2	599.2	600	PN10	780.0	600.0	25	1	120	218	1777	10-M12 x 205	45	68	59.1	
601.0	618.0	500	PN10	728.0	500.0	23	3	255	338	6020	10-M12 x 325	180	203	81.3	
601.0	618.0	600	PN10	780.0	600.0	25	1	120	218	6020	10-M12 x 205	45	68	59.8	
618.0	635.0	600	PN10	780.0	600.0	23	1	120	218	6025	10-M12 x 205	45	68	57.5	
630.0	647.0	600	PN10	780.0	600.0	23	1	120	218	1778	10-M12 x 205	45	68	58.0	
630.0	647.0	600	PN10	780.0	649.0	23	1	120	218	1778	10-M12 x 205	45	68	49.4	
645.2	662.2	600	PN10	780.0	600.0	23	2	205	303	1779	10-M12 x 290	130	153	66.8	
645.2	662.2	600	PN10	780.0	649.0	23	2	205	303	1779	10-M12 x 290	130	153	58.1	
662.0	679.0	600	PN10	790.0	600.0	23	2	205	298	1780	10-M12 x 290	130	153	69.3	
662.0	679.0	600	PN10	790.0	653.0	23	2	205	303	1780	10-M12 x 290	130	153	60.0	
675.0	692.0	600	PN10	802.0	600.0	23	2	205	303	6005	10-M12 x 290	130	153	72.3	
675.0	692.0	600	PN10	802.0	653.0	23	2	205	303	6005	10-M12 x 290	130	153	63.0	
689.0	706.0	600	PN10	816.0	600.0	23	3	260	338	10511/49	10-M12 x 325	185	210	90.3	
695.0	712.0	700	PN10	895.0	714.0	23	1	120	218	6063	12-M12 x 205	45	68	66.1	
699.0	716.0	700	PN10	895.0	718.0	23	1	120	218	10511/50	12-M12 x 205	45	68	65.5	

## Materials & Relevant Standards

### Flange Adaptor Body

Mild Steel to BS EN 10025-2 Grade S275

### End Ring

Rolled Steel to BS EN 10025-2 Grade S275

### Gasket

EPDM Grade "E" to BS EN 681-1 Type WA WRAS Listed

### Bolt Torque / Spanner

Bolt torque - 55-65Nm / Spanner size - A/F 19mm

### Studs, Nuts & Washer

Studs - Steel to BS EN ISO 898-1 Property Class 4.8

Nuts - Steel to BS EN 4190 Grade 4

Washer - Stainless Steel to BS 1449:Part 2 Grade 304 S15

### Coating

Flange Adaptor Body & End Ring = Rilsan Nylon 11 to WIS 4-52-01 Part 1

Bolts & Nuts = Sheraplex to WIS 4-52-03

Every effort has been made to ensure that the information contained in this publication is accurate at the time of publishing. Crane Ltd assumes no responsibility or liability for typographical errors or omissions or for any misinterpretation of the information within the publication and reserves the right to change without notice.



# MaxiDaptor Large Diameter Flange Adaptor PN16

## Specifications

- 1 = Adaptor Body
- 2 = End Ring
- 3 = Gasket
- 4 = Stud, Nut & Washer

Working Pressure = 16bar (water)  
6bar (gas)

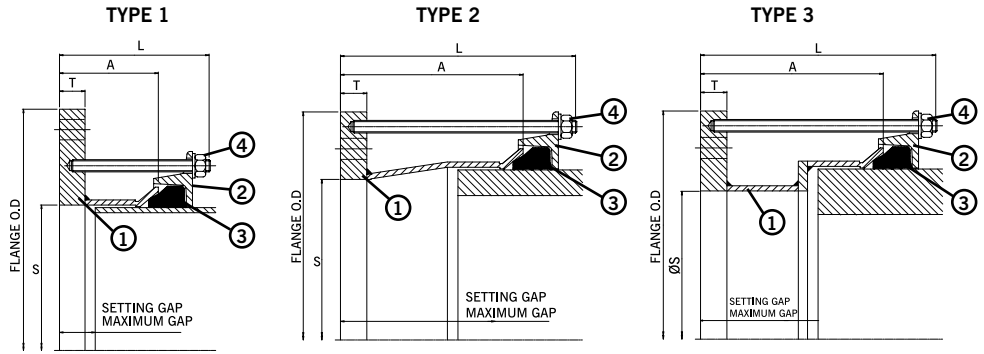

## Flange Adaptor PN16

OD Range		Flange Details								Gasket Mould No.	Studs No.-Dia x Length	Setting Gap		Weight (kg)
Min (mm)	Max (mm)	Nom.	Drilling	Flange Diameter OD (mm)	Flange Bore S (mm)	Flange Thickness T (mm)	Type	Sleeve Length A (mm)	Overall Length L (mm)			Min (mm)	Max (mm)	
348.5	365.5	350	PN16	520.0	367.5	18	2	120	218	6008	8-M12 x 205	45	68	28.5
351.0	368.0	300	PN16	478.0	300.0	18	3	240	333	6002	6-M12 x 325	165	188	38.5
351.0	368.0	300	PN16	478.0	329.0	18	3	240	333	6002	6-M12 x 325	165	188	36.5
351.0	368.0	350	PN16	520.0	370.0	18	1	120	218	6002	8-M12 x 205	45	68	28.6
374.5	391.5	300	PN16	502.0	300.0	18	3	240	333	1659	6-M12 x 325	160	183	43.1
374.5	391.5	350	PN16	520.0	350.0	18	1	120	218	1659	8-M12 x 205	45	68	31.0
374.5	391.5	350	PN16	520.0	393.5	18	1	120	218	1659	8-M12 x 205	45	68	27.5
374.5	391.5	400	PN16	580.0	393.5	25	1	120	218	1659	8-M12 x 205	45	68	41.6
394.3	411.3	350	PN16	522.0	350.0	18	2	205	298	1766	8-M12 x 290	130	153	37.1
394.3	411.3	350	PN16	520.0	397.5	18	2	205	303	1766	8-M12 x 290	130	153	33.1
394.3	411.3	400	PN16	580.0	413.5	25	1	120	220	1766	8-M12 x 205	45	68	39.8
404.8	421.8	400	PN16	580.0	400.0	18	1	120	213	1767	8-M12 x 205	45	68	34.9
404.8	421.8	400	PN16	580.0	424.0	18	1	120	218	1767	8-M12 x 205	45	68	32.8
418.2	435.2	400	PN16	580.0	437.0	18	1	120	218	1784	8-M12 x 205	45	68	32.0
425.0	442.0	400	PN16	580.0	400.0	18	1	120	218	1662	8-M12 x 205	45	68	35.7
425.0	442.0	400	PN16	580.0	444.0	18	1	120	218	1662	8-M12 x 205	45	68	31.6
434.4	451.4	400	PN16	580.0	448.0	18	2	205	303	1768	8-M12 x 290	130	153	37.4
447.2	464.2	400	PN16	580.0	400.0	18	2	205	303	1769	8-M12 x 290	130	153	42.2
447.2	464.2	400	PN16	580.0	448.0	18	2	205	303	1769	8-M12 x 290	130	153	37.7
455.0	472.0	400	PN16	582.0	400.0	18	2	205	298	6003	8-M12 x 290	130	153	42.6
455.0	472.0	450	PN16	640.0	450.0	23	1	120	218	6003	10-M12 x 205	45	68	46.0
455.0	472.0	450	PN16	640.0	474.0	23	1	120	218	6003	10-M12 x 205	45	68	42.8
462.5	479.5	400	PN16	590.0	440.0	25	2	205	303	10511/40	8-M12 x 290	130	153	45.7
467.0	484.0	450	PN16	640.0	486.0	23	1	120	218	6073	10-M12 x 205	45	68	41.6
476.0	493.0	400	PN16	603.0	400.0	23	3	255	338	1770	8-M12 x 325	180	203	60.8
476.0	493.0	450	PN16	640.0	495.0	23	1	120	218	1770	10-M12 x 205	45	68	40.7
487.3	504.3	450	PN16	640.0	506.5	23	1	120	218	1771	10-M12 x 205	45	68	39.4
487.3	504.3	500	PN16	715.0	506.5	23	1	120	218	1771	10-M12 x 205	45	68	53.2
501.9	518.9	450	PN16	640.0	485.5	23	2	205	303	1772	10-M12 x 290	130	153	48.7
501.9	518.9	500	PN16	715.0	500.0	23	1	120	218	1772	10-M12 x 205	45	68	54.7
501.9	518.9	500	PN16	715.0	521.0	23	1	120	218	1772	10-M12 x 205	45	68	51.7
510.0	527.0	450	PN16	640.0	494.0	23	2	205	303	6004	10-M12 x 290	130	153	47.9
510.0	527.0	500	PN16	715.0	500.0	23	1	120	218	6004	10-M12 x 205	45	68	54.9
527.0	544.0	500	PN16	715.0	500.0	23	1	120	218	1773	10-M12 x 205	45	68	55.6
527.0	544.0	500	PN16	715.0	546.0	23	1	120	218	1773	10-M12 x 205	45	68	48.8
540.1	557.1	500	PN16	715.0	559.0	23	1	120	218	1774	10-M12 x 205	45	68	47.2
555.3	572.3	500	PN16	715.0	550.0	23	2	205	303	1775	10-M12 x 290	130	153	56.0
555.3	572.3	600	PN16	840.0	649.5	25	1	120	218	1775	10-M12 x 205	45	68	62.3

## Materials & Relevant Standards

### Flange Adaptor Body

Mild Steel to BS EN 10025-2 Grade S275

### End Ring

Rolled Steel to BS EN 10025-2 Grade S275

### Gasket

EPDM Grade "E" to BS EN 681-1 Type WA WRAS Listed

### Bolt Torque / Spanner

**Bolt torque** - 55-65Nm / **Spanner size** - A/F 19mm

### Studs, Nuts & Washer

**Studs** - Steel to BS EN ISO 898-1 Property Class 4.8

**Nuts** - Steel to BS EN 4190 Grade 4

**Washer** - Stainless Steel to BS 1449:Part 2 Grade 304 S15

### Coating

**Flange Adaptor Body & End Ring** = Rilsan Nylon 11 to WIS 4-52-01 Part 1

**Bolts & Nuts** = Sheraplex to WIS 4-52-03

Every effort has been made to ensure that the information contained in this publication is accurate at the time of publishing. Crane Ltd assumes no responsibility or liability for typographical errors or omissions or for any misinterpretation of the information within the publication and reserves the right to change without notice.

# MaxiDaptor Large Diameter Flange Adaptor PN16

## Specifications

- 1 = Adaptor Body
- 2 = End Ring
- 3 = Gasket
- 4 = Stud, Nut & Washer

Working Pressure = 16bar (water)  
6bar (gas)

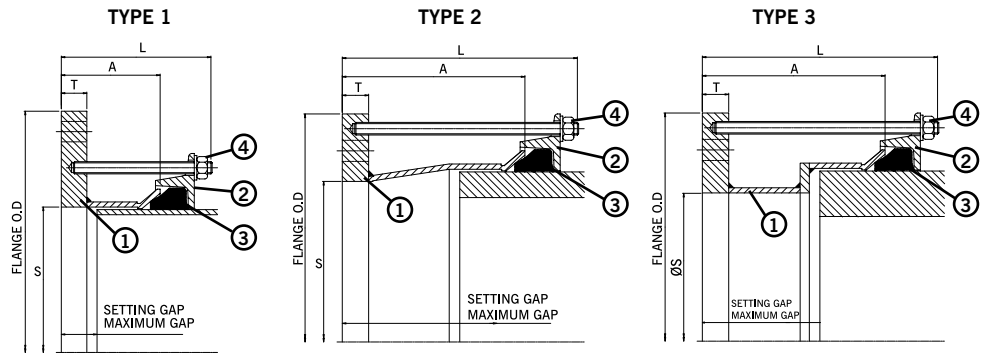

## Flange Adaptor PN16 Continued

OD Range		Flange Details								Gasket Mould No.	Studs No.-Dia x Length	Setting Gap		Weight (kg)
Min (mm)	Max (mm)	Nom.	Drilling	Flange Diameter OD (mm)	Flange Bore S (mm)	Flange Thickness T (mm)	Type	Sleeve Length A (mm)	Overall Length L (mm)			Min (mm)	Max (mm)	
566.5	583.5	500	PN16	715.0	500.0	23	2	205	303	1776	10-M12 x 290	130	153	63.6
566.5	583.5	500	PN16	715.0	550.0	23	2	205	303	1776	10-M12 x 290	130	153	56.2
582.2	599.2	500	PN16	715.0	560.0	23	3	205	303	1777	10-M12 x 290	130	153	60.4
582.2	599.2	600	PN16	840.0	601.0	25	1	120	218	1777	10-M12 x 205	45	68	72.5
601.0	618.0	600	PN16	840.0	600.0	25	1	120	218	6020	10-M12 x 205	45	68	73.4
601.0	618.0	600	PN16	840.0	620.0	25	1	120	218	6020	10-M12 x 205	45	68	69.7
613.0	630.0	600	PN16	840.0	632.0	23	1	120	218	6019	10-M12 x 205	45	68	64.4
618.0	635.0	600	PN16	840.0	637.0	23	1	120	218	6025	10-M12 x 205	45	68	63.6
630.5	647.5	600	PN16	840.0	600.0	23	1	120	218	1778	10-M12 x 205	45	68	70.6
630.5	647.5	600	PN16	840.0	649.5	23	1	120	218	1778	10-M12 x 205	45	68	61.8
645.2	662.2	600	PN16	840.0	664.0	23	1	120	218	1779	10-M12 x 205	45	68	59.7
662.0	679.0	600	PN16	840.0	681.0	23	1	120	218	1780	10-M12 x 205	45	68	57.1
675.0	692.0	600	PN16	840.0	653.0	23	2	205	303	6005	10-M12 x 290	130	153	70.6

## Materials & Relevant Standards

### Flange Adaptor Body

Mild Steel to BS EN 10025-2 Grade S275

### End Ring

Rolled Steel to BS EN 10025-2 Grade S275

### Gasket

EPDM Grade "E" to BS EN 681-1 Type WA WRAS Listed

### Bolt Torque / Spanner

Bolt torque - 55-65Nm / Spanner size - A/F 19mm

### Studs, Nuts & Washer

**Studs** - Steel to BS EN ISO 898-1 Property Class 4.8

**Nuts** - Steel to BS EN 4190 Grade 4

**Washer** - Stainless Steel to BS 1449:Part 2 Grade 304 S15

### Coating

**Flange Adaptor Body & End Ring** = Rilsan Nylon 11 to WIS 4-52-01 Part 1

**Bolts & Nuts** = Sheraplex to WIS 4-52-03

Every effort has been made to ensure that the information contained in this publication is accurate at the time of publishing. Crane Ltd assumes no responsibility or liability for typographical errors or omissions or for any misinterpretation of the information within the publication and reserves the right to change without notice.

# MaxiDaptor Large Diameter Flange Adaptor ANSI Flange Drilling

## Specifications

- 1 = Adaptor Body
- 2 = End Ring
- 3 = Gasket
- 4 = Stud, Nut & Washer

Working Pressure = 16bar (water)  
6bar (gas)

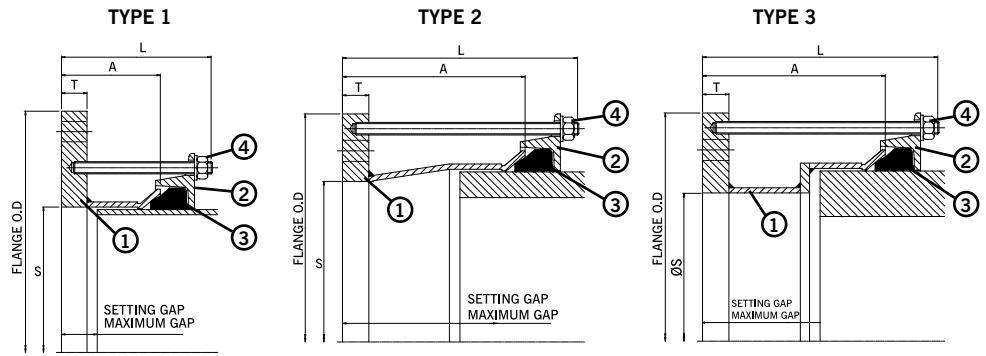

## Flange Adaptor ANSI

OD Range		Flange Details								Gasket Mould No.	Studs No.-Dia x Length	Setting Gap		Weight (kg)
Min (mm)	Max (mm)	Nom.	Drilling	Flange Diameter OD (mm)	Flange Bore S (mm)	Flange Thickness T (mm)	Type	Sleeve Length A (mm)	Overall Length L (mm)			Min (mm)	Max (mm)	
351.0	368.0	14"	ANSI150	533.0	370.0	25	1	120	218	6002	6-M12 x 205	45	68	35.9
374.5	391.5	14"	ANSI150	533.0	393.5	25	1	120	218	1659	6-M12 x 205	45	68	34.0
386.0	403.0	14"	ANSI150	533.0	397.5	25	2	205	218	6035	6-M12 x 290	130	153	39.0
394.3	411.3	14"	ANSI150	533.0	397.5	25	2	205	218	1766	6-M12 x 290	130	153	39.2
404.8	421.8	16"	ANSI150	597.0	424.0	25	1	120	218	1767	8-M12 x 205	45	68	42.2
425.0	442.0	16"	ANSI150	597.0	444.0	25	1	120	218	1662	8-M12 x 205	45	68	40.3
434.4	451.4	16"	ANSI150	597.0	453.5	25	1	120	303	1768	8-M12 x 205	45	68	39.4
439.0	456.0	16"	ANSI150	597.0	458.0	25	1	120	303	6036	8-M12 x 205	45	68	39.0
447.2	464.2	16"	ANSI150	597.0	448.0	25	2	205	303	1769	8-M12 x 290	130	153	46.3
455.0	472.0	16"	ANSI150	597.0	448.0	25	2	205	303	6003	8-M12 x 290	130	153	46.4
455.0	472.0	18"	ANSI150	635.0	474.0	25	1	120	303	6003	8-M12 x 205	45	68	44.0
487.3	504.3	18"	ANSI150	635.0	499.0	25	2	205	303	1771	8-M12 x 290	130	153	47.8
492.0	509.0	18"	ANSI150	635.0	499.0	25	2	205	303	6037	8-M12 x 290	130	153	47.8
501.9	518.9	18"	ANSI150	635.0	499.0	25	2	205	303	1772	8-M12 x 290	130	153	48.0
510.0	527.0	18"	ANSI150	637.0	499.0	25	2	205	303	6004	8-M12 x 290	130	153	48.6
527.0	544.0	20"	ANSI150	698.0	546.0	25	1	120	303	1773	10-M12 x 205	45	68	47.9
540.1	557.1	20"	ANSI150	698.0	550.0	25	2	205	303	1774	10-M12 x 290	130	153	54.4
546.0	563.0	20"	ANSI150	698.0	550.0	25	2	205	303	6038	10-M12 x 290	130	153	54.8
555.3	572.3	20"	ANSI150	698.0	550.0	25	2	205	303	1775	10-M12 x 290	130	153	55.0
565.0	582.0	20"	ANSI150	698.0	550.0	25	2	205	303	1776	10-M12 x 290	130	153	55.1
582.2	599.2	20"	ANSI150	709.0	550.0	25	2	205	303	1777	10-M12 x 290	130	153	57.8
601.0	618.0	24"	ANSI150	813.0	620.0	25	1	120	218	6020	10-M12 x 205	45	68	63.3
630.0	647.0	24"	ANSI150	813.0	649.0	25	1	120	303	1778	10-M12 x 205	45	68	58.7
645.2	662.2	24"	ANSI150	813.0	653.0	25	2	205	303	1779	10-M12 x 290	130	153	66.7
654.0	671.0	24"	ANSI150	813.0	653.0	25	2	205	303	6039	10-M12 x 290	130	153	66.9
662.0	679.0	24"	ANSI150	813.0	653.0	25	2	205	303	1780	10-M12 x 290	130	153	67.0
675.0	692.0	24"	ANSI150	813.0	653.0	25	2	205	303	6005	10-M12 x 290	130	153	67.3

## Materials & Relevant Standards

### Flange Adaptor Body

Mild Steel to BS EN 10025-2 Grade S275

### End Ring

Rolled Steel to BS EN 10025-2 Grade S275

### Gasket

EPDM Grade "E" to BS EN 681-1 Type WA WRAS Listed

### Bolt Torque / Spanner

Bolt torque - 55-65Nm / Spanner size - A/F 19mm

### Studs, Nuts & Washer

**Studs** - Steel to BS EN ISO 898-1 Property Class 4.8

**Nuts** - Steel to BS EN 4190 Grade 4

**Washer** - Stainless Steel to BS 1449:Part 2 Grade 304 S15

### Coating

**Flange Adaptor Body & End Ring** = Rilsan Nylon 11 to WIS 4-52-01 Part 1

**Bolts & Nuts** = Sheraplex to WIS 4-52-03

Every effort has been made to ensure that the information contained in this publication is accurate at the time of publishing. Crane Ltd assumes no responsibility or liability for typographical errors or omissions or for any misinterpretation of the information within the publication and reserves the right to change without notice.

# United Kingdom - Canterbury

# South East Water

MaxiFit Couplings - DN500



## Project

MaxiFit Couplings were used for the emergency repair of a mains pipe in Canterbury. It meant thousands of customers in the city had either no water or low water pressure.

## Client

South East Water





46-48 WILBURY WAY  
HITCHIN, HERTFORDSHIRE  
SG4 0UD. UNITED KINGDOM  
TELEPHONE: +44 (0)1462 443322  
FAX: +44 (0)1462 443311  
EMAIL: [info@vikingjohnson.com](mailto:info@vikingjohnson.com)

[www.vikingjohnson.com](http://www.vikingjohnson.com)

*Every effort has been made to ensure that the information contained in this publication is accurate at the time of publishing. Crane Ltd assumes no responsibility or liability for typographical errors or omissions or for any misinterpretation of the information within the publication and reserves the right to change without notice.*



ISO 14001 • EMS 51874



ISO 9001 • FM 00311



To visit our Video Library go to:  
[www.youtube.com/user/CraneBSU](http://www.youtube.com/user/CraneBSU)

- Designed and manufactured under quality management systems in accordance with BS EN ISO 9001.
- Environmental Management System accredited to ISO 14001.
- For full terms and conditions, please visit our website.

DR7976\_04\_2015

PIONEERS IN PIPE SOLUTIONS



[www.cranesbu.com](http://www.cranesbu.com)

