

## V4250

### Alwa Sampling Valve with Handwheel Sampling valve for chemical and microbiological parameters

#### Product specification sheet

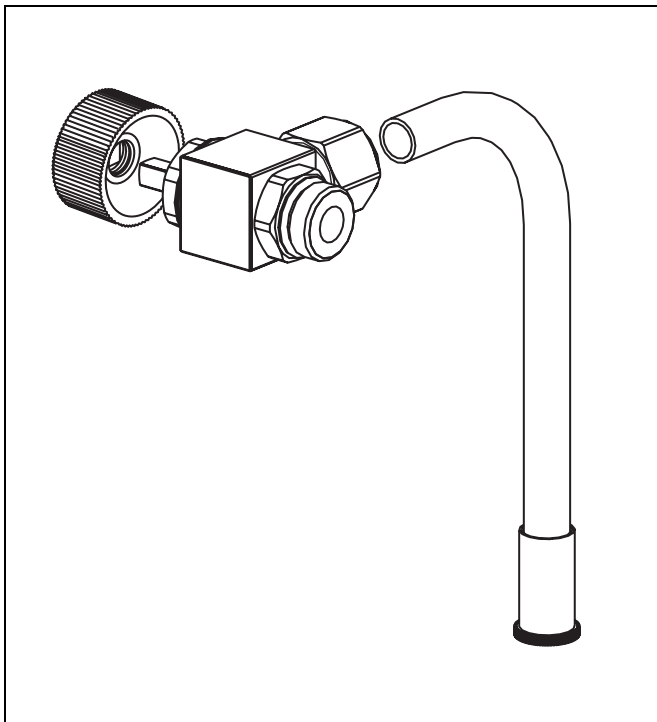

#### Construction

The sampling valve consists of:

- Red bronze housing
- Red bronze piston
- Dezincification resistant brass nut
- Dezincification resistant brass sleeve nut
- Handwheel made of plastic
- Protection cap made of plastic
- Stainless steel outlet pipe
- EPDM gaskets

#### Application

Sampling valve for chemical and microbiological parameters in drinking, bathing and swimming pool water.

Suppliers of drinking water for public use have to commission an annual investigations of water to prevent Legionella occurrence according German regulations TrinW §§4, 14 (6) and 19 (7) and Appendix 4.

There are defined sampling locations for the determination of drinking water system contamination by Legionella.

#### Special Features

- May be retrofitted to any Alwa F/KFR/R fittings from DN15 to DN80
- Valve body and outlet bend may be rotated through 360° and hence may be aligned in any direction
- Outlet volume may be regulated and the valve may be shut off by means of an allen key
- Certificate regarding suitability for sampling in accordance with VDI 6023 and German water regulations
- Correct sampling procedure possible
- A sampling valve for all types of sampling
- All parameters to be determined may be taken at one point
- Horizontal and vertical mounting possible
- Sampling equipment is simple to operate and may be flame sterilised
- Stable, long, stainless steel outlet bend generates a straight water jet
- Valve body and parts in contact with the medium in red bronze
- High quality, hygienic EPDM seat seal with German health ministry plastics and water approval

#### Range of Application

Medium The sampling valve was developed for usage in cold or hot drinking water systems, swimming pools and bathing water systems.

The sampling valve should be used for investigation of Legionella contamination at determined locations in potable water systems.

#### Technical Data

Operating temperature maximum 90 °C

Nominal pressure PN16

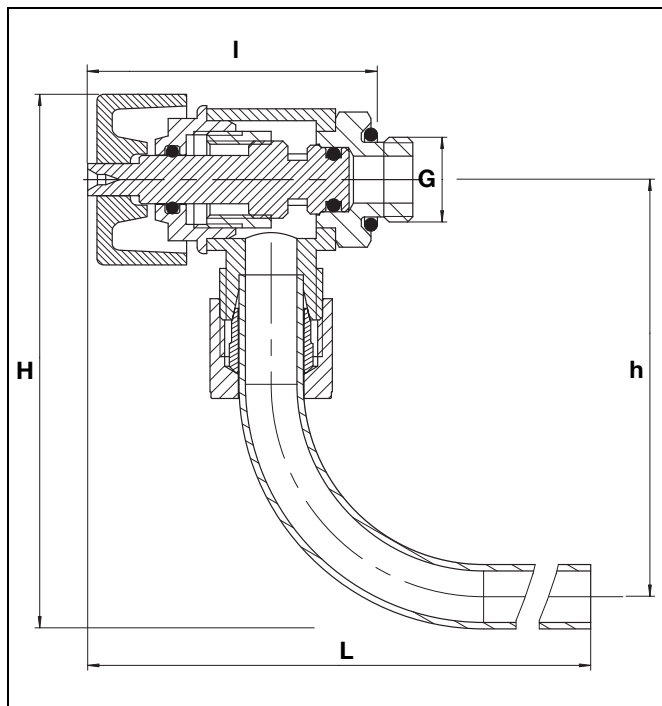

Connection size		DN 6	DN 10
	G		1/4
Dimensions	mm		
	L	153.5	153.5
	I	44	44
	H	82.8	82.8
	h	64.8	64.8

### Installation Guidelines

- Positioning of the sampling location must be determined by the person carrying out sampling. The defined positions must be identified in the plan for sampling locations in drinking water systems.
- The sampling valve can be installed horizontally or vertically to any valve with testing lobes.
- Insure the piping system is pressure-free before installing the sampling valve
- The valve housing is only tightened at closed position due to possibility to align valve to right position during installation.
- Please check for closed condition after installing.

### Method of Operation

Operators who supply drinking water to the public must commission tests for legionella once a year.

There are often no suitable sampling valves in the drinking water system, so that sampling takes an unnecessarily long time and cannot always be carried out correctly.

The sampling valve may be fitted horizontally or vertically on any Alwa F/KFR/R fitting with a drain plug.

A flame is applied around the fitting to disinfect the stainless steel outlet pipe. The sampling valve can be regulated and the flow volume regulated with an allen spanner.

The sample is taken beneath the installation. Splashing is minimised by the form of the outlet pipe.

The stainless steel outlet tube can be swung out of the operating area to either side.

### Options

V4250A008H Sampling valve with handwheel green, connection size G<sup>1/4</sup> for building valves up to DN25

V4250A010H Sampling valve with handwheel green, connection size G<sup>3/8</sup> for building valves from DN32 to DN80

V4250A008P Sampling valve with handwheel black, connection size G<sup>1/4</sup> for building valves up to DN25

V4250A010P Sampling valve with handwheel black, connection size G<sup>3/8</sup> for building valves from DN32 to DN80

### Spare Parts

Handwheel green (5 pieces) VS4250H

Handwheel black (5 pieces) VS4250P

### Automation and Control Solutions

Honeywell GmbH  
 Hardhofweg  
 74821 MOSBACH  
 GERMANY  
 Phone: (49) 6261 810  
 Fax: (49) 6261 81309  
<http://ecc.emea.honeywell.com>

Manufactured for and on behalf of the  
 Environmental and Combustion Controls Division  
 of Honeywell Technologies Sàrl, Z.A. La Pièce 16,  
 1180 Rolle, Switzerland by its Authorised Representative Honeywell GmbH

EN0H-1816GE23 R1014  
 Subject to change  
 © 2014 Honeywell GmbH

**Honeywell**