

Light is OSRAM



SubstiTUBE® Advanced HF – ST5A-1.5m-26W-HF

Preliminary Datasheet



Innovative LED-lamp, easy and safe to use in ECG installations as direct retrofit. Energy saving potential of up to 50% by replacing 1.5 m T5 fluorescent tubes. Instant 100% light without flickering. No mercury.

Applicable in warehouses, cold storage, supply rooms, corridors, industry, stairways, garages, etc; for applications with high operating hours.

Technical operating data

Product	Color	Colortemp. [K]	Lum. Flux [lm]	Voltage [V] / Frequency [Hz] / Input current [mA]	Power [W]	Radiance-Angle [°]
ST5A-1.5m-26W-865-HF	Cool Daylight	6500 K	3920	220 - 240 V / 50 / 60 Hz / 295 mA	26 W	180 °
ST5A-1.5m-26W-840-HF	Cool White	4000 K	3920			

All Data are related to the entire lamp. Due to the special conditions of the manufacturing processes of LED the typical data of technical parameters can only reflect statistical figures and do not necessarily correspond to the actual parameters of each single product which could differ from the typical data.

Technical Features

- Full-glass LED lamp in T5 shape with G5 socket
- Weight: 185g
- For operation at ECG; no modification necessary
- Direct Retrofit for ECG luminaires by replacement of lamp
- High color homogeneity
- Powerfactor > 0.9
- Up to 60,000 h lifetime
- Switching cycles > 200.000
- Color Rendering Index (CRI) > 80
- Overpower, overheat and short circuit protected
- Not for operation with CCG, not dimmable
- RoHS-conformity, no mercury
- Energy Efficiency Class: A++

Minimum / Maximum ratings

	Maximum temperature at Tc test point	Storage temperature Ts	Ambient temperature Ta
ST5A-1.5m- HF	-20° ... 65°C	-20° ... 80°C	-20° ... 45°C

Drawings

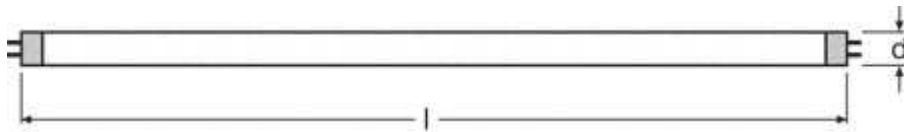

Product	l	d
ST5A-1.5m-HF	1449 mm	17 mm

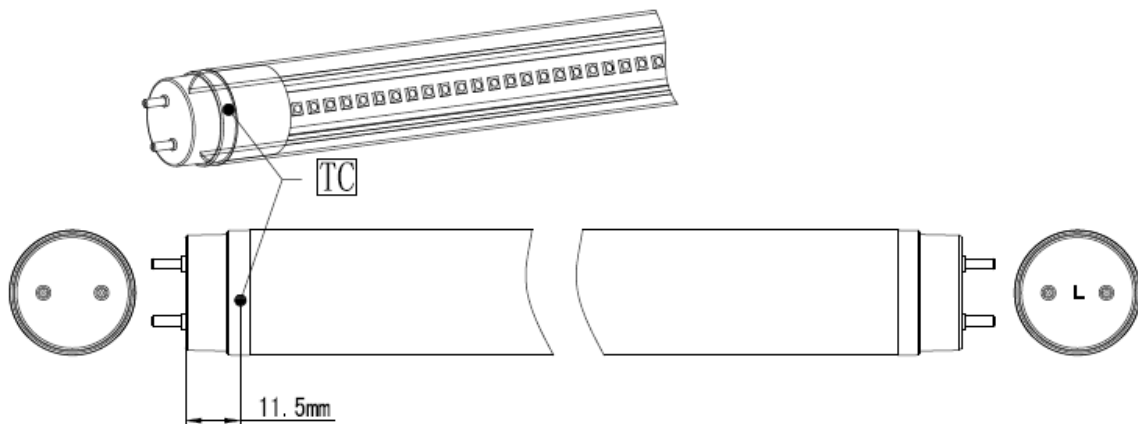

VDE in preparation



Safety and Application notes

- Use SubstiTUBE[®] Advanced HF luminaires which do **not** have any starter.
- SubstiTUBE[®] Advanced HF is designed for general lighting service and must not be damaged or operated in a damaged condition.
- Since only the lamp is replaced, no constructive modification to the luminaire is necessary.
- SubstiTUBE[®] Advanced HF is compatible with ECGs of various brand manufacturers. For further information regarding the tested ECGs a compatibility list can be found on the following page.
- The compatibility list is based upon testing conducted by the manufacturer in a lab simulated environment, and the results can vary in certain field applications due to a number of factors. OSRAM does not take over any responsibility, warranty or liability that these results can also be achieved by using the devices under other conditions, or when using successor models of the tested devices, or different models of the same manufacturer. In case of non-observance of the instructions, safety risks like overheating of SubstiTUBE[®] or ECG may occur in rare cases.
- SubstiTUBE[®] Advanced HF emits light only with a limited angle, not like a fluorescent tube with 360° output.
- This lamp may not be suitable for use in all applications where a traditional fluorescent lamp has been used.
- The temperature range of this lamp is more restricted.
- Due to the characteristic light distribution of SubstiTUBE[®] Advanced HF, the resulting luminaire light characteristic is likely to change. It is not guaranteed that e.g. standards for lighting at working places will be complied to after replacement. A photometric check of the installation is recommended.
- Luminous flux and power consumption will change in dependency of used ballast.
- The effective energy savings depend on the efficiency of the luminaire setup to be replaced and should be considered individually in each case.
-  The SubstiTUBE[®] Advanced HF is protected according to IP20. Applications with external risk of moisture and dust can be served with an adequately protected luminaire.
- Photobiological safety of lamps and lamp systems according to IEC 62471:
Risk group: Exempt
- SubstiTUBE[®] Advanced HF is designed for standard lamp-holders. Some lamp-holders, e.g. push-in fixing without a rotor, are not suitable for SubstiTUBE[®] Advanced UO HF.



Lamp suitable for high frequency operation (HF)



Lamp not suitable for emergency operation



Dimming not allowed

Kompatibilitätsliste

		SubstiTUBE Advanced T5 1.5m 26W HF
OSRAM	QTP5 1X49	1x
OSRAM	QTP5 2X49	2x
OSRAM	QT-FIT5 1X49	1x
OSRAM	QT-FIT5 2X49	2x
Philips	HF-P 249 TL5 HO III 220-240V 50/60Hz IDC	2x
Philips	HF-S 249 TL5 II 220-240V 50/60Hz	2x
Philips	HF-S 149 TL5 II 220-240V 50/60Hz	1x
Philips	HF-Performer Intelligent 2 28/35/49/80 TL5 EII 220-240V	2x
Philips	HF-Performer Intelligent 1 28/35/49/54 TL5 220-240V	1x
Philips	HF-Performer Intelligent 1 28/35/49/80 TL5 EII 220-240V	1x
Philips	HF-Performer Intelligent 2 28/35/49/54 TL5 220-240V	2x
Tridonic	PC 1x49 T5 PRO Ip	1x
Tridonic	PC 2x49 T5 PRO Ip	2x
Tridonic	PC 1x49 T5 TOP Ip	1x
Tridonic	PC 2x49 T5 TOP Ip	2x
Tridonic	PC 1/49 T5 INDUSTRY	1x
Tridonic	PC 2/49 T5 INDUSTRY	2x
Helvar	EL1x49s	1x
BAG	BCS49.1FX-11/220-240	1x
BAG	BCS49.2FX-11/220-240	2x

Installation Instructions for ECG

Below an example for typical lamp holder types is described

- Make sure that the supply voltage is disconnected (1).
- Turn the conventional lamp 90° (2) and take it out of the socket carefully (3).
- Insert SubstiTUBE® Advanced HF into socket (4) and locate into position by turning 90° (5).
- Activate tube by pushing the two safety buttons (6), (7).
- Connect SubstiTUBE® Advanced HF to supply voltage (8).
- Check light emission direction (9).

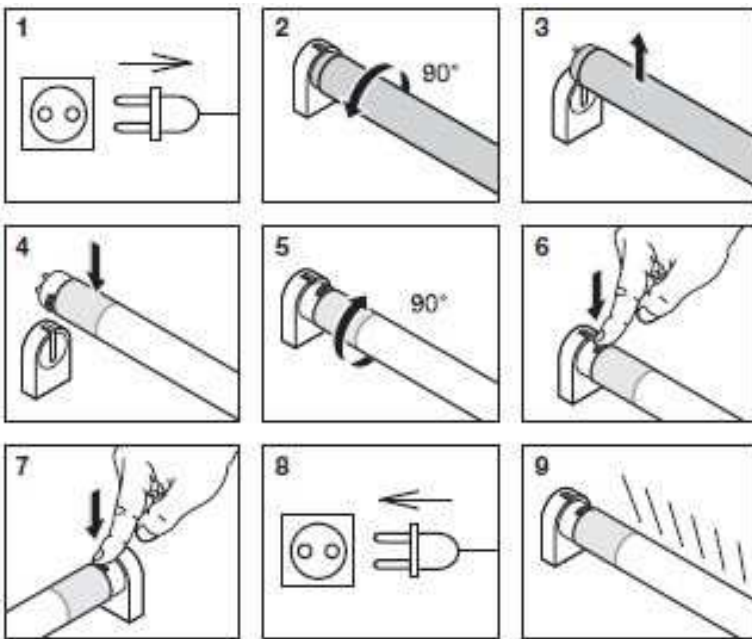

Ordering guide

Product name	Light color	EAN*	S-Unit**
ST5A-1.5m-26W-865-HF	Cool Daylight / 6500 K	4052899956681	25 x 1
ST5A-1.5m-26W-840-HF	Cool White / 4000 K	4052899956674	

* EAN: Ordering number per single module

** S-Unit: Lamps per shipping unit

Sales and Technical Support

Sales and technical support is given by the local OSRAM subsidiaries.

On our worldwide homepage all OSRAM subsidiaries are listed with complete address and phone numbers.

Further Information

➤ Downloads: Eulumdat /IES files, CE declaration

www.osram.com/SubstiTUBE

OSRAM GmbH

Head Office:

Marcel-Breuer-Strasse 6
80807 Munich, Germany
Phone +49 89 6213-0
www.osram.com

