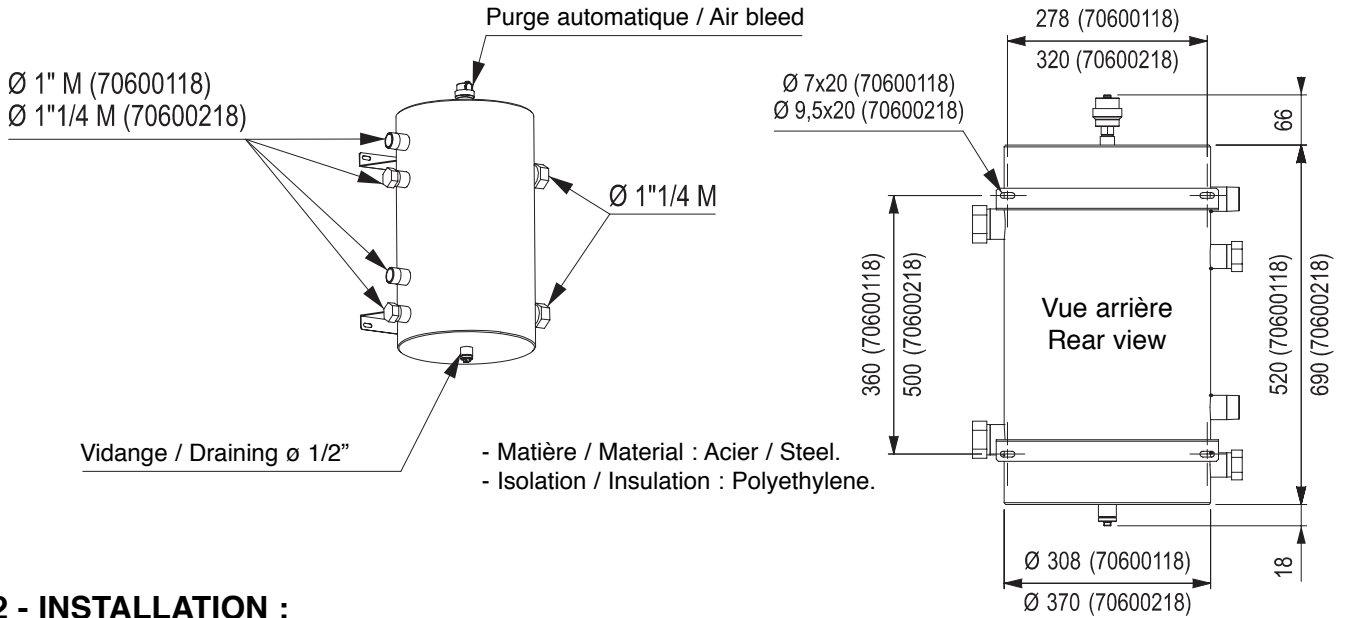
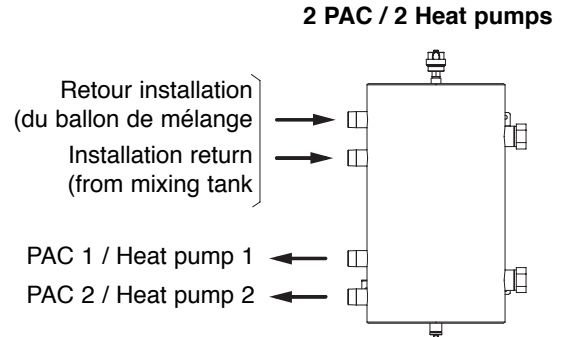
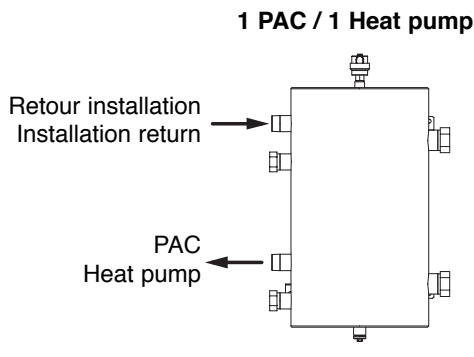

1 - DESCRIPTION :

2 - INSTALLATION :
2.1 - BALLON TAMPON / BUFFER TANK

2.2 - BALLON MÉLANGE / MIXING TANK
