



BESKRIVELSE

P102/0

Kraftig kuglehane med fuldt gennembløb.
 Pres x mufte. Blåt T-greb.
 Med boring i kugle for legionella- og frostsikring ved åben tilstand.

TEA overfladebehandling.

I henhold til EN 1254/7 og EN13828 standarder.

DIMENSIONER

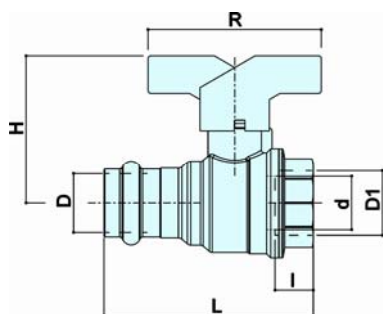

D [mm]	15	18	22	28
d	15	15	20	25
H	46	46	55,5	65
L	73,5	75	82	95,5
R	58	58	65	75
I	17	17	18	21,5
D1 (Rp)	1/2"	3/4"	3/4"	1"
Acc.	1	1	2	3
g	220	330	350	600

Alle varianter er i overensstemmelse med ISO 7/1 eller ISO 228 standarder.

MATERIALER



Ventilhus CuZn36Pb2As Cw602N (DIN 50930 part.6)
TEA-belægning

Kugle CuZn39Pb3 Cw614N (DIN 50930 part.6)
Diamantslebet og TEA-belægning

Spindel CuZn36Pb2As Cw602N (DIN 50930 part.6)

Pakdåse CuZn39Pb3 Cw614N (DIN 50930 part.6)
Justerbar

Pakninger PTFE

O-ringe 2 x EPDM
PTFE pakning

Greb Aluminium

VARIANTER

P102 Pres x pres, blå T-greb
 P102/0 Pres x M, blå T-greb
 P102/1 Pres x N, blå T-greb
 P102/3 Pres x forskrunding, blå T-greb

GREBSVARIANTER

P100 Grønt stål-greb
 P102 Blåt T-greb
 P102T Plastik-greb

Godkendelser



TRYKTABSDIAGRAM

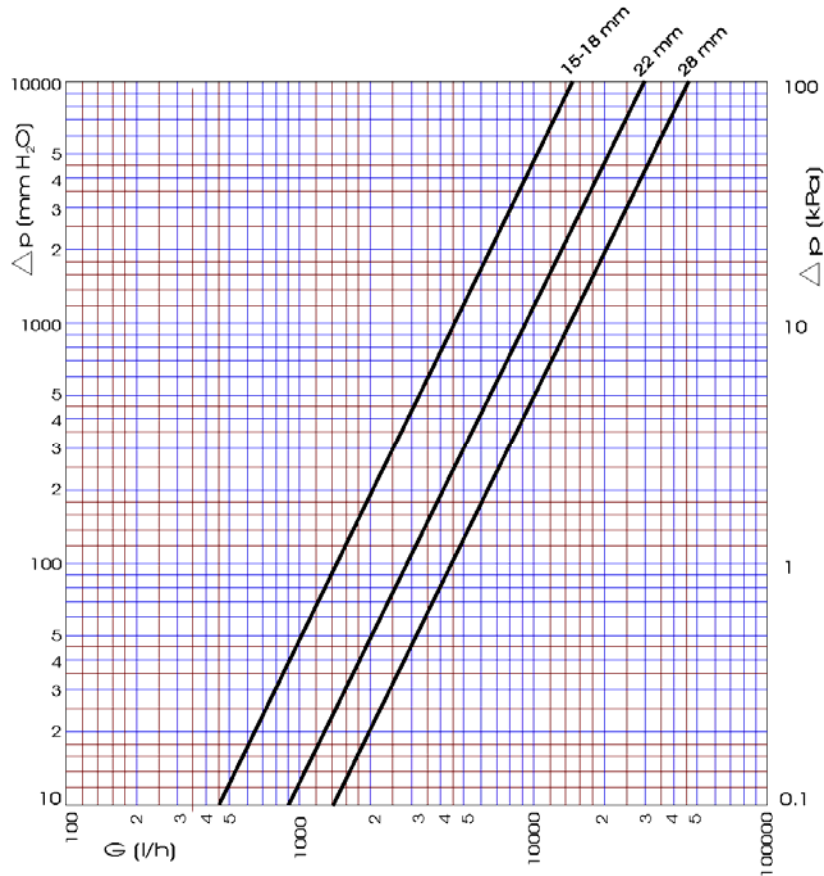

D [mm]	15	18	22	28
Kv	14.5	14.5	30	45
PN	16	16	16	16

ANBEFALET DRIFTSTEMPERATUR/MAKSIMALTRYK

16 bar - 30°C - non shock
 10 bar - 95°C - non shock

