

Technical manual

Sylax butterfly valves (DN 25-350 mm)

sylax^x

Summary



• Sale leaflet	p.2
• Nomenclature	p.3
• Overall dimensions	p.4
• Top connections of the actuators	p.5
• Actuators	p.6
• Connecting flanges	p.7-8
• Normalisation	p.9
• Pressure	p.10
• Torque values - Pressure/Temperature diagram	p.11
• Flow rate (Kv)	p.12
• Head loss chart (Δp)	p.13
• Type of flange/ Tag/Traceability	p.14
• Bolts and nuts	p.15-17
• Installation	p.18

Applications and main characteristics

Industrial processes and general services

Applications :

- Water distribution and supply with the main European approvals, water treatment, most of the fluids of general services.
- Industrial applications such as : *Metallurgical, mining, paper-making, shipbuilding, nuclear, environmental and mechanical, food industry (see our list of approvals).*
- For special applications, especially for particularly difficult media, contact our technical back office team.
- For vacuum and frequencies above 1 cycle / min, the headline will be pasted.

Main characteristics :

- Multiple connections : centering lugs, tapped lugs.
- Vertical and horizontal operating position.
- High power transmission with robust grooved connection between the shaft and the disc.
- Easy maintenance by removing the circlips
- Interchangeable disc and liner.
- Complete recyclability of the butterfly valve
- Body in cast iron GJL1040, ductile iron GJS1030 , steel and stainless steel.
- Body epoxy coated 80 μ m colour blue RAL 5017 (a lot of other coatings on option, please ask our sales department)
- Wide choice of actuators.

Sale leaflet

By concentrating the technologies and by integrating technical solutions of the highest levels, Socla fulfils its ambition :

- competitiveness of a standard range,
- reliability,
- comprehensive range thanks to a multiplicity of solutions.

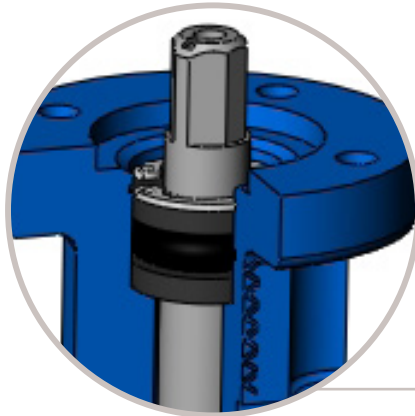
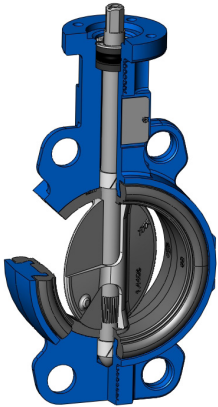

- Safety anti-ejection circlip keeps shaft in place and allows easy maintenance
- Safety reinforced by a secondary water-tightness.
- Spline driven one piece shaft connected to floating disc :

. high reliability of tightness and torque transmission in the long term.

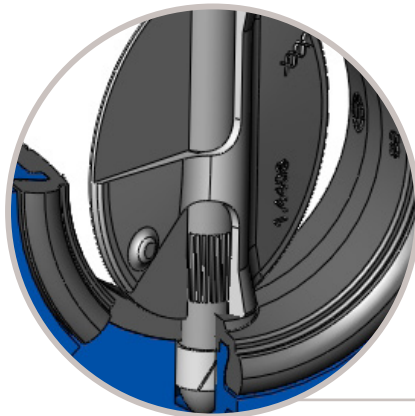

- High power transmission with robust grooved connection between the shaft and the disc.
- Complete protection of the shaft and valve body from fluids.
- Reliability of movements with self-lubricating bearings.

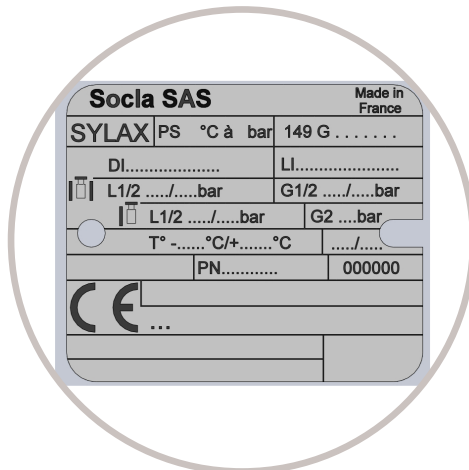

- Identification and traceability ensured by riveted metal tag : see on page 14.

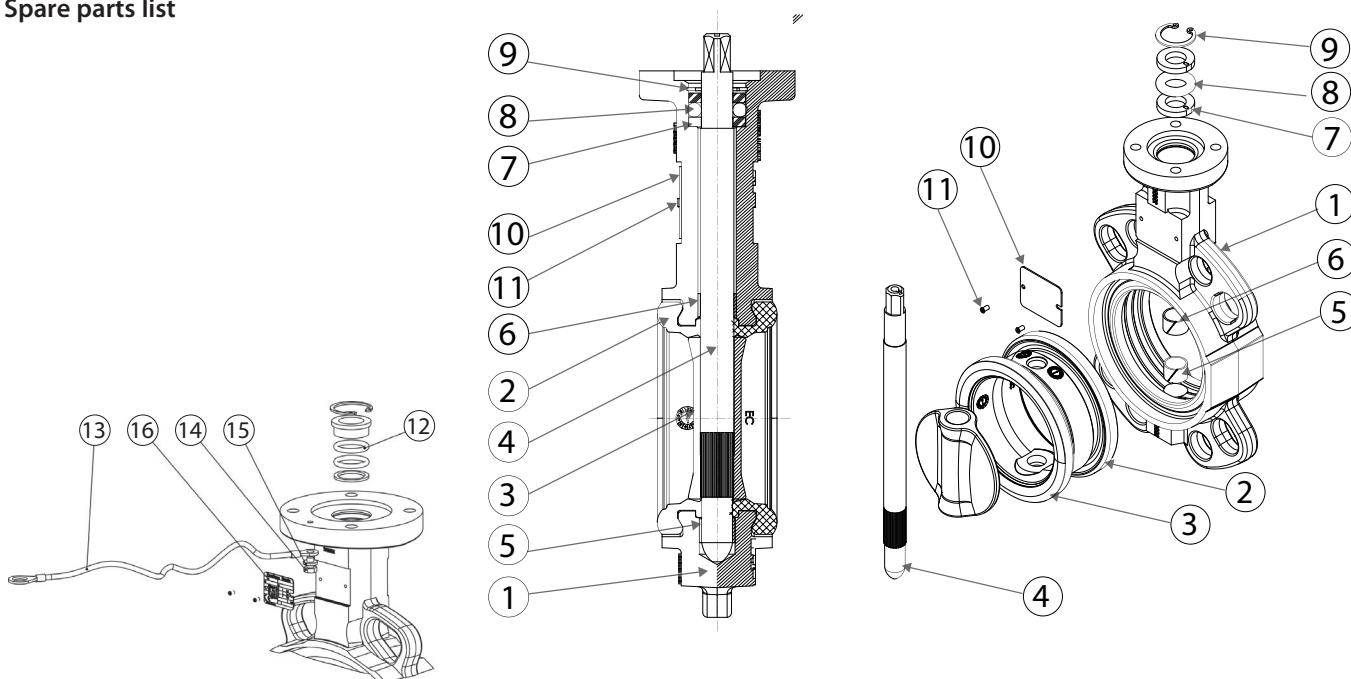
Spare parts list

Nb	DESCRIPTION	Qty	MATERIALS ACCORDING TO NORMS			
			Materials	EN	ASTM	JIS
1	Body	1	Ductile iron	EN GJS 400-15 (JS 1030)	-	FCD40
			Cast iron	EN GJL 250 (JL 1040)	-	FC25
			Steel*	GE 280 (E280 - 480M)	gr WCB	-
			Stainless steel*	GX5 CrNiMo 19-11-2 (1.4408)	316	SUS 316
2	Liner	1	EPDM	-	-	-
			White EPDM	-	-	-
			High content nitrile	-	-	-
			White nitrile	-	-	-
			Carboxylated nitrile	-	-	-
			CSM (Polyethylen chloro-sulfonated)	-	-	-
			Silicone	-	-	-
			FKM	-	-	-
			Buthyl	-	-	-
			Natural rubber	-	-	-
3	Disc	1	Ductile iron	EN GJS 400-15 (JS 1030)	-	FCD40
			Stainless steel	GX5 CrNiMo 19-11-2 (1.4408)	316	SUS 316
			Alu-bronze*	CuAl10Fe5Ni5 (CC333G)	-	-
4	Stem	1	Stainless steel	X5 CrNiCuNb 16-4 (1.4542)	630	SUS 630
			Stainless steel°	X2 CrNiMo 17-12-2 (1.4404)	316L	SUS 316L
			Stainless steel	X30 Cr13 (1.4028)	420	SUS 420 J2
5 - 6	Anti-friction bearing	1	Zinc coated steel + PTFE	-	-	-
7	Sealing and anti-extrusion bush	2	Plastic	Grivory XE3883 black 9915 GV4	-	-
8	O-ring seal	1	Nitrile/FKM	-	-	-
9	Circlips	1	Stainless steel	X30 Cr13 (1.4028)	420	SUS 420 J2
10	Identification plate	1	Steel	XC 75	-	-
			Aluminium	EN AW - AL995 (EN AW - 1050A)	-	-
11	Rivet	2	Alu / Stainless steel	-	-	-

* Except DN200

° Except DN200 and 250

ATEX special spare parts list

12	Braid	1	Tinned copper	-	-	-
13	Discharge electro-static braid	1	Tinned copper	-	-	-
14	Screw	1	Stainless steel	A2 - 70	304	SUS 304
15	Stop washer	1	Stainless steel	X5 CrNi 18-10 (1.4301)	304	SUS 304
16	ATEX identification plate	1	Aluminium	EN AW - AL995 (EN AW - 1050A)	-	-

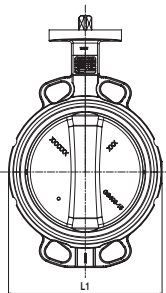
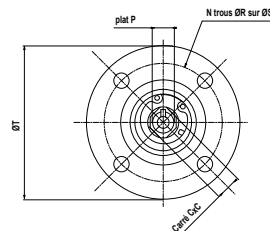
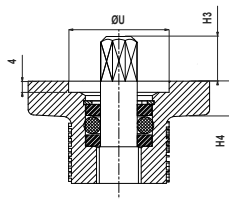
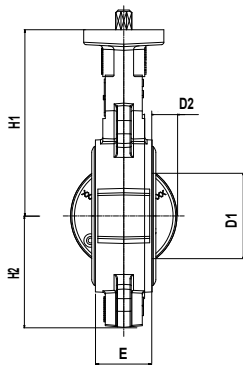
Overall dimensions

• 4 Centring lugs

Diameter		Face to face	Overall dimensions				ISO Top according to ISO 5211					Square drive outlet			Travel of the disc		Weight kg		
DN	NPS	E	L1	H1	H2	H4	N	øR	øS	øT	øU	N°	□C	H3	Plat P	D1	D2	(1)	(2)
25	1	32	100	125	50	12	4	6,5	50	65	36	F05	11	16	11	6	1	-	1,6
32/40	1 1/2	32	144	130	57	12	4	6,5	50	65	36	F05	11	16	11	31	6,5	1,9	1,7
50	2	43	121	136	62	12	4	6,5	50	65	36	F05	11	16	11	35	6	2,6	2,6
65	2 1/2	46	136	145	84	12	4	6,5	50	65	36	F05	11	16	11	55	13	2,9	2,9
80	3	46	127	151	89	12	4	6,5	50	65	36	F05	11	16	11	73,5	20	3,6	3,6
100	4	52	149	175	106	10	4	6,5	50	65	36	F05	11	16	11	87	25	4,4	4,4
125	5	56	182	190	120	12	4	8,5	70	90	56	F07	14	19	14	118,5	37,5	6,2	6,3
150	6	56	209	203	131	12	4	8,5	70	90	56	F07	14	19	14	146,5	50,5	7,1	7,3
200	8	60	265	225	165	12	4	8,5	70	90	56	F07	14	19	14	190	70	11,2	11,2
250	10	68	316	266	196	14	4	10,5	102	125	71	F10	17	24	20	242	92	17,1	
300	12	77	368	290	238	14	4	10,5	102	125	71	F10	22	29	16	292,5	112,5	23,8	
350	14	77	421	305	270	16	4	12,5	125	150	87	F12	27	29	-	333	132,5	33,2	

(1) Ductile iron body (JS1030), ductile iron disc (JS1030), EPDM liner. - (2) Cast iron body (JL1040), ductile iron disc (JS1030), EPDM liner.

• 2 Centring lugs

Diameter		Face to face	Overall dimensions				ISO Top according to ISO 5211					Square drive outlet			Travel of the disc		Weight kg		
DN	NPS	E	L1	H1	H2	H4	N	øR	øS	øT	øU	N°	□C	H3	Plat P	D1	D2	(1)	(2)
32/40	1 1/2	32	106/99	130	56	12	4	6,5	50	65	36	F05	11	16	11	31	6,5	1,7	1,6
50	2	43	121/99	136	73	12	4	6,5	50	65	36	F05	11	16	11	35	6	2,6	2,1
65	2 1/2	46	136/117	145	82	12	4	6,5	50	65	36	F05	11	16	11	55	13	3,1	2,4
80	3	46	150/136	151	93	12	4	6,5	50	65	36	F05	11	16	11	73,5	20	3,2	2,8
100	4	52	166/167	175	106	12	4	8,5	70	90	56	F07	14	19	14	87	25	5,3	4,4
125	5	56	132/194	190	127	12	4	8,5	70	90	56	F07	14	19	14	118,5	37,5	6,6	5,7
150	6	56	139/225	203	147	12	4	8,5	70	90	56	F07	14	19	14	146,5	50,5	8,1	6,8

(1) Stainless steel body (1.4408), stainless steel disc (1.4408), EPDM liner. - (2) Steel body (WCB), stainless steel disc (1.4408), EPDM liner.

• Tapped lugs and lugs with unthreaded holes*

Diameter		Face to face	Overall dimensions				ISO Top according to ISO 5211					Square drive outlet			Travel of the disc		Weight kg		
DN	NPS	E	L2	H1	H2	H4	N	øR	øS	øT	øU	N°	□C	H3	Plat P	D1	D2	(1)	(2)
32/40	1 1/2	32	146	130	57	12	4	6,5	50	65	36	F05	11	16	11	31	6,5	1,9	2,7
50	2	43	121	136	62	12	4	6,5	50	65	36	F05	11	16	11	35	6	3	3,3
65	2 1/2	46	135	145	70	12	4	6,5	50	65	36	F05	11	16	11	55	13	3,3	3,9
80	3	46	179	151	89	12	4	6,5	50	65	36	F05	11	16	11	73,5	20	4,2	4,8
100	4	52	206	175	103	10	4	6,5	50	65	36	F05	11	16	11	87	25	6	
125	5	56	238	190	119	12	4	8,5	70	90	56	F07	14	19	14	118,5	37,5	6,2	9,7
150	6	56	265	203	133	12	4	8,5	70	90	56	F07	14	19	14	146,5	50,5	7,1	11,2
200	8	60	325(1)-313(2)	225	163(1)-157(2)	12	4	8,5	70	90	56	F07	14	19	14	190	70	15,7	14,3
250	10	68	397	266	198	14	4	10,5	102	125	71	F10	17	24	20	242	92	23	
300	12	77	454	290	227	14	4	10,5	102	125	71	F10	22	29	16	292,5	112,5	34	
350	14	77	497	305	248	16	4	12,5	125	150	87	F12	27	29	-	331	132	46	

*the version «lugs with unthreaded holes» replaces the double flange version

(1) Ductile iron body (JS1030), ductile iron disc (JS1030), EPDM liner - (2) Stainless steel body (1.4408), stainless steel disc (1.4408), EPDM liner.

• Double flanges

Diameter		Face to face	Overall dimensions				ISO Top according to ISO 5211					Square drive outlet			Travel of the disc		Weight kg		
DN	NPS	E	L3	H1	H2	H4	N	øR	øS	øT	øU	N°	□C	H3	Plat P	D1	D2	(1)	(2)
250	10	68	406	266	201	14	4	10,5	102	125	71	F10	17	24	20	242	92	27	
300	12	77	483	290	242	14	4	10,5	102	125	71	F10	22	29	16	292,5	112,5	43	
350	14	77	534	305	256	16	4	12,5	125	150	87	F12	27	29	-	331	132	56	

Connecting kit for actuations

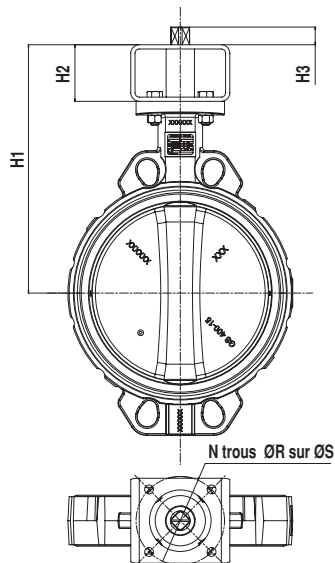

We recommend direct mounting of the actuation, otherwise see table below.

DN	NPS	Iso top of the valve	Iso top of the actuation															
			F03		F04		F05		F07		F10		F12		F14		F16	
			H1	H2	H1	H2	H1	H2	H1	H2	H1	H2	H1	H2	H1	H2	H1	H2
32	1 1/4	F05/□11	190		190		190		190		210							
40	1 1/2		190		190		190		190		210							
50	2		199	60	199		199		199		219							
65	2 1/2		205		205		205	60	205	60	225							
80	3		210		210	60	210		210		230	80						
100	4	235		235		235		235		255								
125	5	F07/□14			249		249		249	60	269							
150	6				262		262	60	262	60	282							
200	8				285		285		285		305							
250	10	F10/□17			346		346	80	346	80	346	80						
300	12	F10/□22			370		370	80	370	80	370	80	370	80	370	80	370	80
350	14	F12/□27																

DN	NPS	Iso top of the valve	Kit	Exceeding length for the shaft H3									
				□9	□11	□14	□17	□22	□27	□36	□46		
32	1 1/4	F05/□11	F03										
40	1 1/2		F04										
50	2		F05	7	9	12	15	20	25				
65	2 1/2		F07										
80	3		F10										
100	4	F07/□14	F04										
125	5		F05										
150	6		F07		9	12	15	20	25	34			
200	8	F07/□14	F04										
250	10	F10/□17	F05		9	12	15	20	25	34			
300	12	F10/□22	F07			12	15	20	25	34			
350	14	F12/□27	F10				15	20	25	34	48		

N°	N	øR	øS
F03	4	5,5	36
F04	4	5,5	42
F05	4	6,5	50
F07	4	8,5	70
F10	4	10,5	102
F12	4	12,5	125
F14	4	17	140
F16	4	22	165

Reminder of the iso top dimensions EN ISO 5211 (see also the overall dimensions).

Other special executions on request : actuated by par square drive and flat according to EN ISO 5211, subjected to technical feasibility.

Actuations

Find below the different standard assembly combinations.

For any other information, please ask our technical Department.

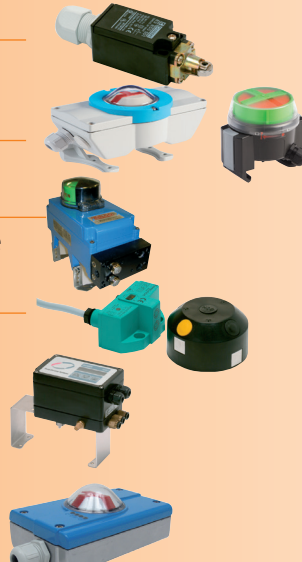
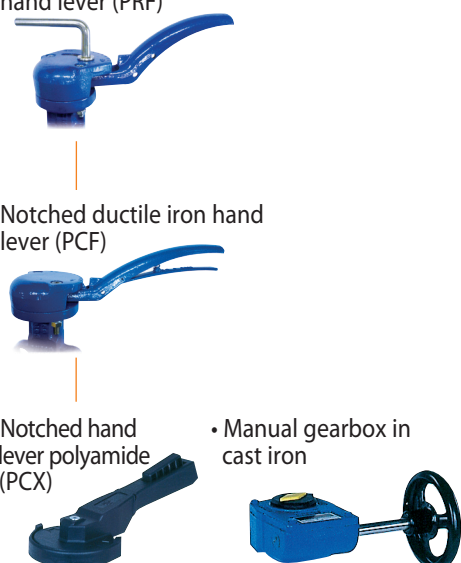
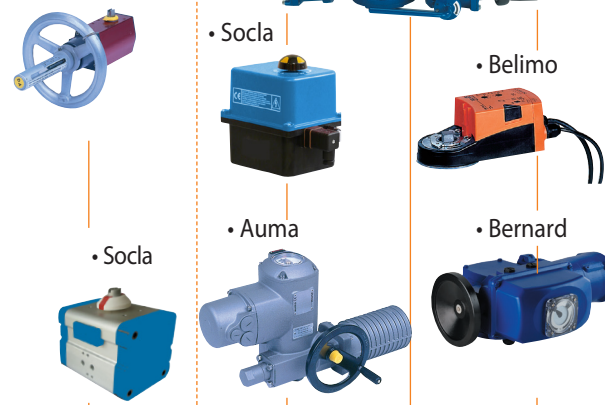
<p>ASSEMBLY LEVEL 2</p>	<ul style="list-style-type: none"> • 1 or 2 mechanical limit switch • Switchbox : <ul style="list-style-type: none"> . mechanical . inductive . inductive + solenoid valve . mechanical + solenoid valve • Inductive limit switch • Positioners (1) <ul style="list-style-type: none"> . BURKERT 1067 	<p><i>For other options, please consult us.</i></p>
<p>ASSEMBLY LEVEL 1</p>	<ul style="list-style-type: none"> • Adjustable ductile iron hand lever (PRF) • Notched ductile iron hand lever (PCF) • Notched hand lever polyamide (PCX) • Manual gearbox in cast iron  <p>HAND LEVER GEAR BOX</p>	<ul style="list-style-type: none"> • Remote control + emergency hand wheel • Socla • Rotork • Belimo • Auma • Bernard  <p>PNEUMATIC ACTUATOR ELECTRIC ACTUATOR</p>



(1) Pneumatic actuator only

Connecting flanges

The Sylax 25-350 mm butterfly valve can be mounted with the following connections (other types on request) :

• 4 Centering lugs

- ✓ : possible mounting
- : possible mounting with re-machining
- : possible mounting but special reference
- : impossible mounting

Diameter		EN1092-1 & EN1092-2					ASME/ANSI B16.1 Class 125	ASME/ANSI B16.5 Class 150	ASME/ANSI B16.5 Class 300	BS10		JIS B2238 et JIS B2239		
DN	NPS	PN6	PN10	PN16	PN25	PN40				Table D	Table E	5K	10k	16k
25	1	✓(1)	✓(1)	✓(1)	✓(1)	✓(1)	✓(1)	✓(1)	✓(1)	✓(1)	✓(1)	●	✓	●
32	1 1/4	✓	✓	✓	✓	✓	✓(2)	✓(2)	✓	●	●	●	✓	●
40	1 1/2	✓	✓	✓	✓	✓	✓	✓	●	✓	✓	●	✓	●
50	2	✓	✓	✓	✓	✓	✓	✓	●	✓	✓	●	●	●
65	2 1/2	✓	✓	✓	✓	✓	✓	✓	●	●	●	✓	✓	●
80	3	✓	✓	✓	✓	✓	✓	✓	●	✓	✓	✓	●	●
100	4	✓	✓	✓	✓	✓	✓	✓	●	✓	✓	●	●	✓
125	5	✓	✓	✓	●	●	✓	✓	●	✓	✓	✓	✓	●
150	6	✓	✓	✓	●	●	✓	✓	●	✓	✓	✓	✓	●
200	8	✓	✓	✓	●	●	✓	✓	●	✓	✓	●	●	●
250	10	✓	✓	✓	●	●	✓	✓	■	●	✓	✓	✓	●
300	12	✓	✓	✓	✓	●	✓	✓	●	✓	✓	✓	✓	✓
350	14	✓	✓	✓	✓	●	✓	✓	■	✓	✓	●	●	✓

(1) Cast iron body GJL-250 (JL1040) only.

(2) Cast iron body GJL-250 (JL1040) only; re-machining for ductile iron body GJS 400-15 (JS1030)

• 2 Centering lugs (3)

Diameter		EN1092-1 & EN1092-2					ASME/ANSI B16.1 Class 125	ASME/ANSI B16.5 Class 150	ASME/ANSI B16.5 Class 300	BS10		JIS B2238 et JIS B2239		
DN	NPS	PN6	PN10	PN16	PN25	PN40				Table D	Table E	5K	10k	16k
32	1 1/4	✓	✓	✓	✓	✓	✓	✓	○	✓	✓	✓	✓	✓
40	1 1/2	✓	✓	✓	✓	✓	✓	✓	○	✓	✓	✓	✓	✓
50	2	○	✓	✓	✓	✓	✓	○	○	○	○	○	○	○
65	2 1/2	○	✓	✓	○	○	✓	✓	○	✓	○	○	✓	○
80	3	○	✓	✓	✓	✓	✓	○	○	○	○	○	○	○
100	4	○	✓	✓	○	○	✓	✓	○	○	○	○	○	○
125	5	○	✓	✓	○	○	✓	✓	○	○	○	○	○	○
150	6	○	✓	✓	○	○	✓	✓	○	✓	○	○	○	○

(3) Body in stainless steel (1.4408) and in steel (WCB)

• Tapped lugs

Diameter		EN1092-1 & EN1092-2					ASME/ANSI B16.1 Class 125	ASME/ANSI B16.5 Class 150	ASME/ANSI B16.5 Class 300	BS10		JIS B2238 et JIS B2239		
DN	NPS	PN6	PN10	PN16	PN25	PN40				Table D	Table E	5K	10k	16k
32	1 1/4	○	✓	✓	✓	✓	○	○	○	○	○	○	○	○
40	1 1/2	○	✓	✓	✓	✓	○	○	○	○	○	○	○	○
50	2	○	✓	✓	✓	✓	○	○	■	○	○	■	○	○(4)
65	2 1/2	○	✓	✓	○	○	○	○	■	○	○	○	○	○
80	3	○	✓	✓	✓	✓	○	○	○	○	○	○	○	○
100	4	○(5)	✓	✓	○	○	○	○	■	○(5)	○	○	○	○
125	5	✓	✓	✓	✓	✓	✓	✓	✓	✓	✓	✓	✓	✓
150	6	✓	✓	✓	✓	✓	✓	✓	✓	✓	✓	✓	✓	✓
200	8	✓	✓	✓	■	■	○	○	■	○	○	○	■	○(1)
250	10	○	✓	✓	○	■	○	○	■	■	○	○	○	■
300	12	○	✓	✓	■	■	○	○	■	○	○	○	■	■
350	14	■	✓	✓	■	■	○	○	■	○	○	○	○	○

DN65 PN10/16 4 holes

(4) Possible mounting for ductile iron body GJS 400-15 (JS1030), impossible mounting for body in cast iron GJL-250 (JL1040) and in stainless steel.

(5) Possible mounting if the butterfly valve is inclined at 22,5°

Attention : the Sylax 25-350 mm lug type body is not a multi-connection body (connection to many flanges of different sizes). Generally, every connection relates to a different reference of finished products.

• Double flanges

Diameter		EN1092-1 & EN1092-2					ASME/ANSI B16.1 Class 125	ASME/ANSI B16.5 Class 150	ASME/ANSI B16.5 Class 300	BS10		JIS B2238 et JIS B2239		
DN	NPS	PN6	PN10	PN16	PN25	PN40				Table D	Table E	5K	10k	16k
250	10	○	✓	✓	■	■	○	○	■	○	○	○	○	■
300	12	○	✓	✓	○	■	○	○	■	○	○	○	○	○
350	14	○	✓	✓	■	■	○	○	■	○	○	○	○	○

Connecting flanges
• End of line mounting and downstream removing

The end of line mounting and the downstream removing, at ambient temperature, of the Sylax 25-350 mm butterfly valve is limited to the pressure mentioned on page 11 according to the PED directive 2014/68/UE.

These mountings are only possible on tapped lugs and lugs with unthreaded holes.

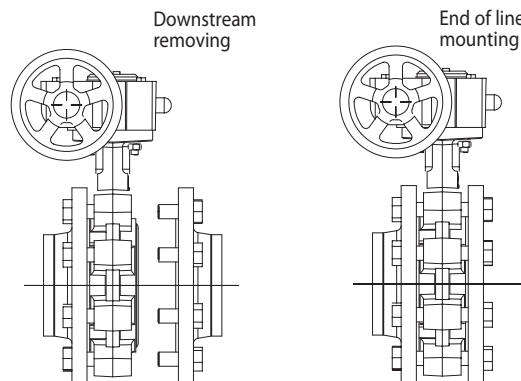

For wafer type bodies with 4 centering lugs, the end of line mounting can be done in the following conditions :

- ambient temperature
- For water or non dangerous liquids (L2)
- For butterfly valves PFA 16 bar between flanges
- For butterfly valves with ductile iron body
- For butterfly valves with liners in EPDM or high content nitrile
- Within a short period (such as maintenance, ...), 15 days maximum
- In pressure conditions (PFA or PS) such as : see table

DN	PFA or PS (bar)
32 to 150	10
200 to 300	8

Use nuts with reduced face-to-face dimensions between the flange to be dismantled and the centering lugs.

Use washers, wide ones if needed, in order to mount the nuts on the lugs.

The mounting and the removing must be done successively and in opposite way on each nut.

For the mounting, apply a reasonable torque on the nuts, in order not to damage the lugs, until metal-metal contact between flange and body.

For flanges with 8 rods, only 4 are used to maintain the valve in downstream removing ; the 8 rods must be re-mounted for a normal use between flanges .

In case of unexpected downstream removing, integrate and screw successively and in opposite way, between the lugs and the flange to be removed, the 4 nuts which hold the butterfly valve.

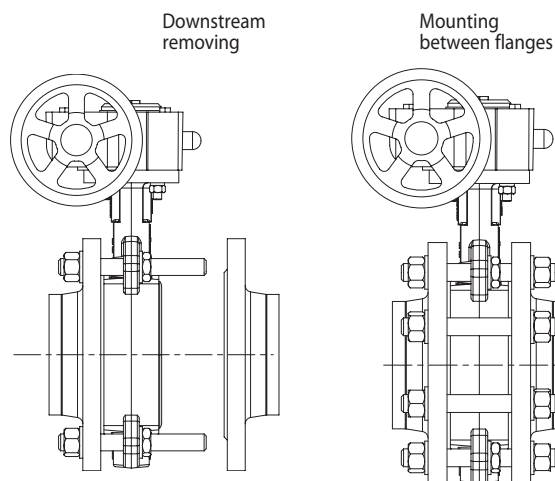

Normalisation
• Iso top connection for actuations :

According to EN ISO 5211

• Face to face :

According to 558-1 series 20
ISO 5752 series 20
API 609 table 2

• Connecting flanges : see on page 8

According to EN1092-1 and EN1092-2
ASME/ANSI B16.5
BS10-d and BS10-e
JIS B2238 and JIS B2239

• Tests :

According to EN12266-1

Resistance and tightness of the body : test P11(1,5 x allowable operating pressure)
Tightness of the seat : test P12 rate A (1,1 x allowable operating pressure)

According to EN12266-2

Anti-static design : test F21

• European Directives :

Our butterfly valves are in accordance to the safety requirements of the following directives. :

Directive 2014/68/UE : Equipments under pressure PED (Pressure Equipment Directive)

Applies to the design, manufacturing and the assessment of the conformity of pressure equipment, the maximum allowable pressure of which is 0.5 bar.

Pressure equipment for water supply, distribution, and disposal of water is excluded.

Depending on the type of pressure equipment, maximum allowable temperature (PS), DN, physical nature of the fluid (liquid, gas or vapour) and the degree of danger of the fluid (group1/2)*, the directive classifies this same equipment into different categories (article 3.3, I, II, III, IV), required for the assessment of conformity with CE marking.

The equipment defined in article 3.3 of the directive must not bear the CE marking.

(* Group 1 : hazardous fluids (directive 67/548/EEC) / explosive / highly flammable /easily flammable / flammable / very toxic / toxic / combustion agents.

Group 2 : all other fluids

Important notice : the indicated pressure for the different categories of fluids (L1/L2/G1/G2) is under no condition a guarantee of use.

Therefore, it is essential to validate the use of products under given operating conditions. Socla is not responsible for alteration of the products to working conditions not previously specified by the customer.

In order to facilitate your choice regarding these new regulatory requirements, Socla has put the necessary information concerning products with CE marking, specification sheets and product identification plates at your disposal in the price list (+ see additional explanations on the detachable slip).

In addition, the operating instructions are available on our web site www.socla.com or by simple request from our sales department.

Machinery Directive 2006/42/CE : Machinery Directive

In its Appendix I it sets a certain number of Essential Health and Safety Requirements which must be met. It applies to motorised butterfly valves, (with electric, pneumatic or hydraulic actuators). According to this Directive, these sets are "Partly Completed Machineries" designed for being integrated into a machine.

"Partly Completed Machinery" means an assembly which is almost machinery but which cannot in itself perform a specific application. A drive system is partly completed machinery. Partly completed machinery is only intended to be incorporated into or assembled with other machinery or other partly completed machinery or equipment, thereby forming machinery to which this Directive applies.

Pressure
DIRECTIVE 2014/68/UE Equipments under pressure.

Products manufactured in conformity with the requirements of the directive, according to pressure, DN and fluid (see on the precedent page).

LINERS		DN mm	Cat.	MOUNTING	PFA	PS			
						L1	L2	G1	G2
6 bar	EPDM, Nitrile (CC333G disc), White EPDM	32 to 150	3,3	Flanges	6	6	6		6
				End of line	4	4	4		4
	Nitrile (except CC333G disc), Neoprene, Butyl, Hypalon, Natural rubber, White natural rubber.	200 to 350	I	Flanges	6	6	6		6
				End of line	4	4	4		4
		32 to 100	I	Flanges	6	6	6	6	6
				End of line	4	4	4		4
125 to 350	II	Flanges	6	6	6	6	6		
		End of line	4	4	4		4		
10 bar	EPDM, Nitrile (CC333G disc), White Nitrile, Carboxylated Nitrile , White EPDM	25 to 100	3,3	Flanges	10	10	10		10
				End of line	6	6	6		6
		125 & 150	I	Flanges	10	10	10		10
				End of line	6	6	6		6
	200 to 350	I	Flanges	10	10	10		10	
			End of line	6	6	6		6	
		25	3,3	Flanges	10	10	10	10	10
				End of line	6	6	6		6
	Nitrile (except CC333G disc), FKM	32 to 100	I	Flanges	10	10	10	10	10
				End of line	6	6	6		6
		125 to 350	II	Flanges	10	10	10	10	10
				End of line	6	6	6		6
Silicone	32 to 100	I	Flanges	10	10	10	10	10	
			End of line	6	6	6		6	
	125 to 150	II	Flanges	10	10	10	10	10	
			End of line	6	6	6		6	
200 to 350	II	Flanges	6	6	6	6	6		
		End of line	4	4	4		4		
16 bar	EPDM, Nitrile (CC333G disc)	32 to 100	3,3	Flanges	16	16	16		10
				End of line	12	12	12		10
		125	I	Flanges	16	16	16		10
				End of line	12	12	12		10
		150	I	Flanges	16	10	16		10
				End of line	12	6	12		10
	200 to 300	I	Flanges	16	10	16		10	
			End of line	10	6	10		10	
	Nitrile (except CC333G disc), Neoprene, Butyl, Hypalon, Natural rubber, White natural rubber	32 to 100	I	Flanges	16	16	16	10	16
				End of line	12	12	12		12
		125 & 150	II	Flanges	16	16	16	10	16
				End of line	12	12	12		12
200 to 300		II	Flanges	16	16	16	10	10	
			End of line	10	10	10		10	
350	II	Flanges	16	16	16	10	10		
		End of line	8	8	8		8		
20 bar	EPDM, Nitrile (CC333G disc)	32 to 250	3,3	Flanges	20		20		
				End of line	12		12		
		300 & 350	I	Flanges	20		20		
	End of line			12		12			
	Nitrile (except CC333G disc), Neoprene, Butyl, Natural rubber, White natural rubber	32 to 100	3,3	Flanges	20	20	20		
				End of line	12	12	12		
125 to 350		II	Flanges	20	20	20			
	End of line		12	12	12				
25 bar	EPDM, Nitrile (CC333G disc)	32 to 150	3,3	Flanges	25		25		
				End of line	16		16		
	Nitrile (except CC333G disc)	32 to 80	3,3	Flanges	25	25	25		
				End of line	16	16	16		
		100 to 150	II	Flanges	25	25	25		
				End of line	16	16	16		

NOTE : Butterfly valves of category II used as «end of line», please consult us.

ATTENTION
 Gas G1 and G2 : The max. pressure is 6 bar when using cast iron 5.1301(EN-GJL-250).

PS : Maximum allowable pressure (in bar) according to Directive 2014/68/UE

PFA : Allowable operating pressure (in bar) for supply, distribution and disposal of water.

Torque values

Wet torques (Nm)		25	32	40	50	65	80	100	125	150	200	250	300	350
PS6	EPDM	10	10	10	10	10	20	22	40	45	85	200	280	400
	NBR	10	12	12	12	20	22	30	55	85	115	255	380	560
PS16	EPDM	10	10	10	10	18	25	46	50	60	120	280	430	500
	NBR	10	12	12	12	28	32	55	80	100	150	450	600	720

NOTE :
One actuation minimum per month.

Pressure/temperature diagram

EPDM liner DN 25 up to 350

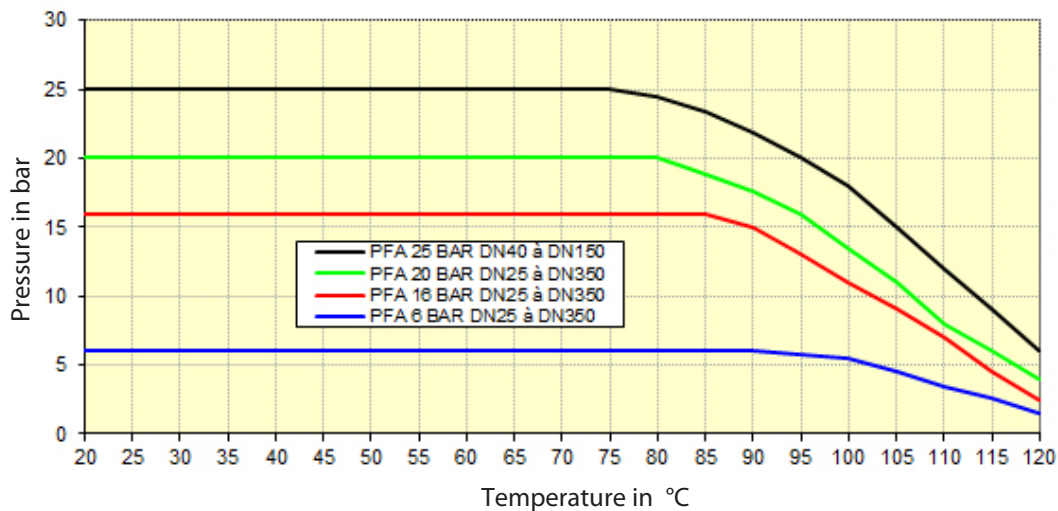

For every other elastomer, please ask our sales department.

Flow rate (Kv)

OPENING STAGE - Stainless steel disc									
DN	10°	20°	30°	40°	50°	60°	70°	80°	90°
25	-	-	-	3	8	16	27	35	40
32/40	-	-	-	5	12	25	40	56	62
50	-	-	1	8	18	33	54	71	79
65	-	-	6	19	41	76	118	158	174
80	-	3	18	43	79	138	211	252	275
100	-	15	38	83	154	253	368	458	496
125	-	20	61	134	249	399	599	792	883
150	5	37	100	200	374	600	863	1109	1212
200	15	76	200	399	680	1099	1666	2196	2500
250	40	150	333	621	1084	1765	2452	3517	3948
300	60	219	500	989	1736	2770	4097	5118	5635
350	145	420	882	1676	2850	4462	6000	7431	8520

The butterfly valve is not the best product for regulating Nevertheless, the Sylax 25-350 mm butterfly valve can be used to regulate by an opening stage between 30° and 90°.

A regulation in the opening stage lower than 30° is not advisable because of over speed, cavitation effect, which could damage prematurely the valve.

Kv = volume of water in m³/h through a valve at a preset opening stage and under a head loss of 1 bar.

The maximum flow velocity of the fluid through the valve must not exceed :

- 3 m/s for liquid fluids. Between 3 and 5m/s, the use of the Sylax 25-350 mm butterfly valve is possible, but the phenomena of cavitation, noise, vibration and water hammering increase.
- 20m/s for gas. Between 20 and 25m/s, the use of the Sylax 25-350 mm butterfly valve is possible, but the phenomena of cavitation, noise, vibration and water hammering increase.

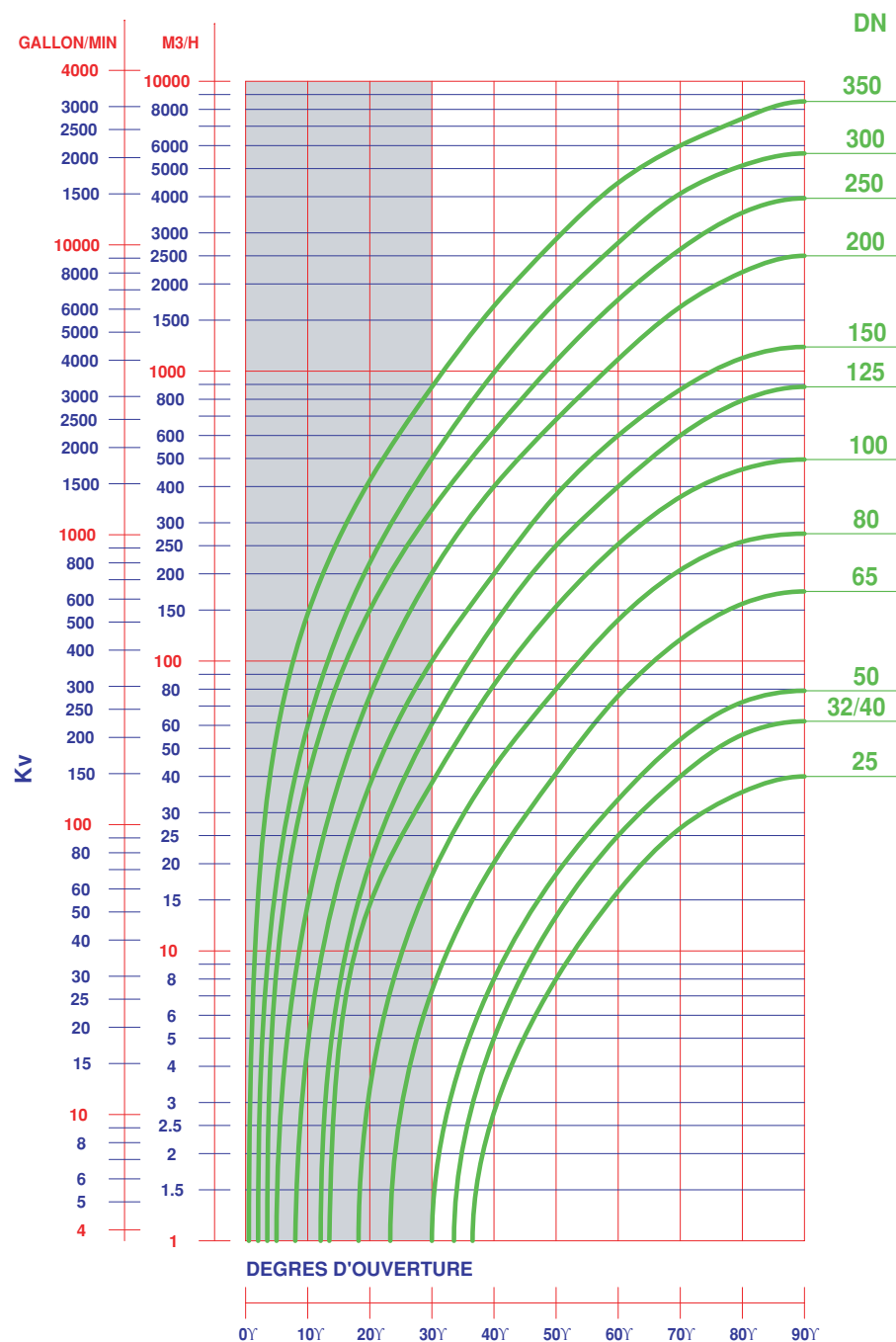

Headloss diagram (Δp)

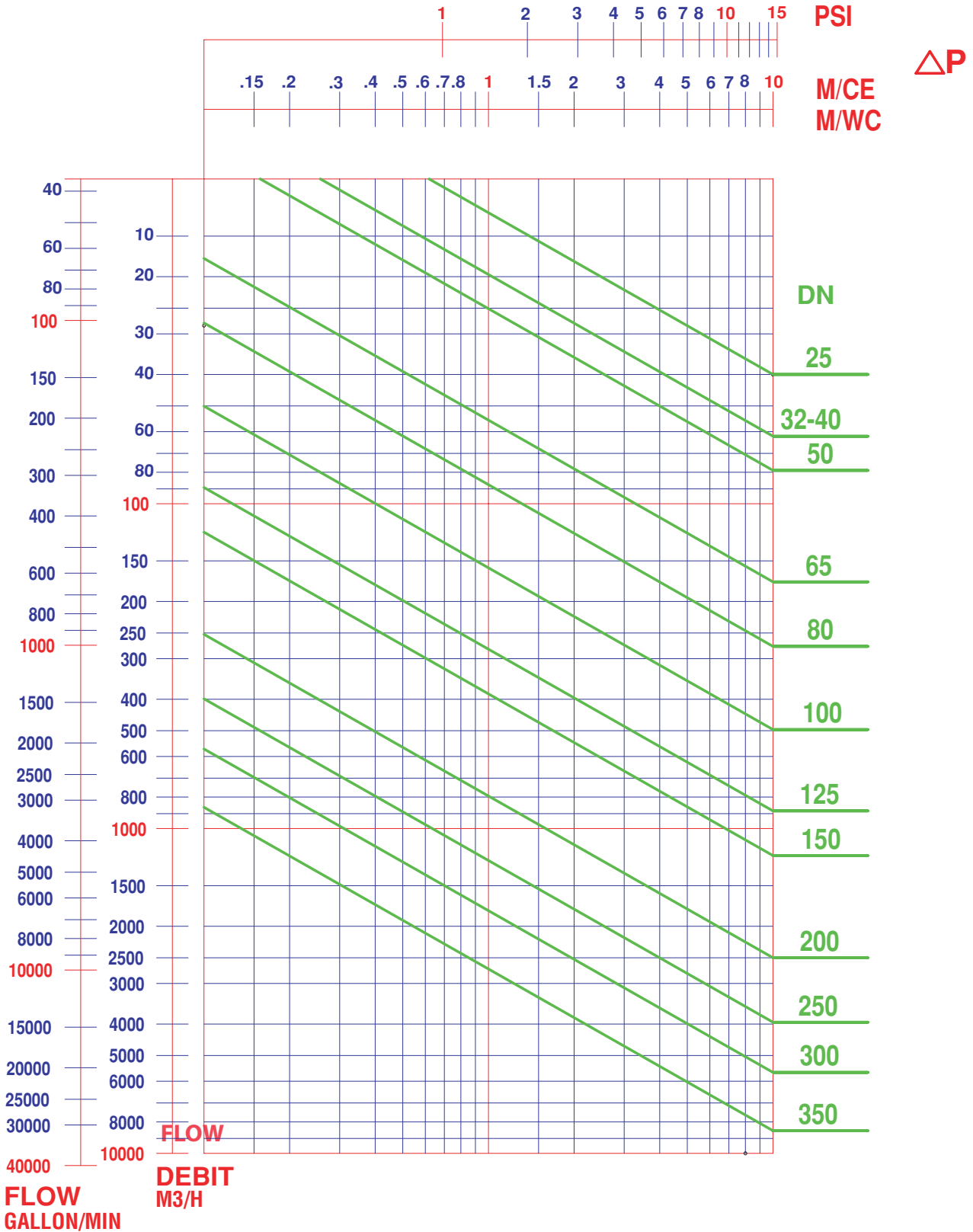

Type of flange

The Sylax 25-350 mm butterfly valve has been designed to be mounted on normalised standard flanges. Only standard flanges type 11, 21 and 34 according to EN 1092 are quite compatible.

For other types of flanges, refer to the table below.
Non appropriate connections will cancel our guarantee.

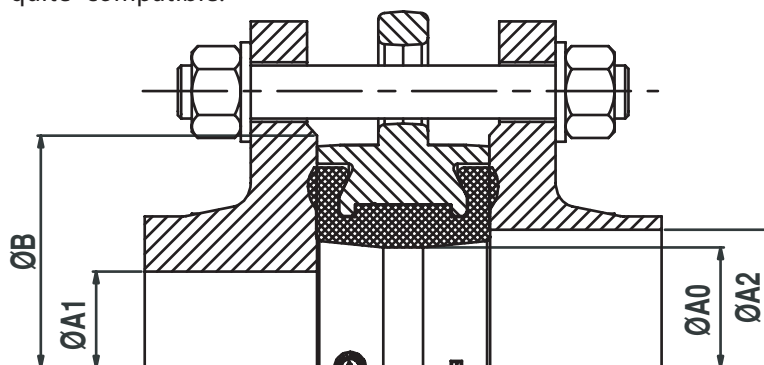

DN		Ø A0	Ø A1 mini	Ø A2 maxi	Ø B mini
25	1	32	-	44	60
32	1 1/4	43	35	51	80
40	1 1/2	43	35	51	80
50	2	54	42	60	90
65	2 1/2	70	62	74	110
80	3	85	82	91	128
100	4	100	97	108	148
125	5	125	128	143	178
150	6	150	156	166	202
200	8	200	200	224	258
250	10	250	252	280	313
300	12	300	303	329	365
350	14	340	344	369	418

NOTE : The use of expansion seals, as well as the use of elastomer coated flanges, between the flange and the valve are strictly forbidden.

Tag / traceability

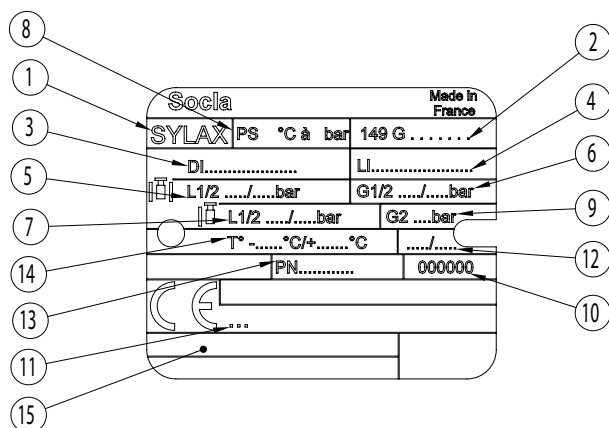

Rep	Description
1	Name of the valve
2	Reference
3	Material of the disc
4	Material of the liner
5	Pressure PS between flanges L1/L2 (liquid)
6	Pressure PS between flanges G1/G2 (gas)
7	Pressure PS end flange L1/L2 (liquid)
8	Pressure PFA water 20°C
9	Pressure PS end flange G2 (gas)
10	Number of manufacturing order
11	Notified Body Number for the Directive PED 2014/68/UE
12	Manufacturing date
13	Connecting flanges
14	Limit of use
15	Approval information zone

Bolts and nuts
Note : Bolts and nuts are not part of our standard supply

DN	NPS	a	e	EN 1092 PN6			EN 1092 PN10			EN 1092 PN16			EN 1092 PN25			ASME / ANSI B16.5 Class 150			
				*Nb rods or Nb screw	ØV	c	*Nb rods or Nb screw	ØV	c	*Nb rods or Nb screw	ØV	c	*Nb rods or Nb screw	ØV	c	*Nb rods or Nb screw	ØV Metric	ØV UNC**	c
25	1	32	--	4	M10	16	4	M12	18	4	M12	18	4	M12	18	4	M14	1/2"	18
32/40	1 1/2	32	14	4	M12	18	4	M16	24	4	M16	24	4	M16	24	4	M14	1/2"	18
50	2	43	18	4	M12	18	4	M16	24	4	M16	24	4	M16	24	4	M16	5/8"	24
65*	2 1/2	46	20	4	M12	18	8*	M16	24	8*	M16	24	8	M16	24	4	M16	5/8"	24
80	3	46	20	4	M16	24	8	M16	24	8	M16	24	8	M16	24	4	M16	5/8"	24
100	4	52	24	4	M16	24	8	M16	24	8	M16	24	8	M20	26	8	M16	5/8"	24
125	5	56	26	8	M16	24	8	M16	24	8	M16	24	8	M24	32	8	M20	3/4"	26
150	6	56	26	8	M16	24	8	M20	26	8	M20	26	8	M24	32	8	M20	3/4"	26
200	8	60	28	8	M16	24	8	M20	26	12	M20	26	12	M24	32	8	M20	3/4"	26
250	10	68	32	12	M16	24	12	M20	26	12	M24	32	12	M27	32	12	M24	7/8"	26
300	12	77	36	12	M20	26	12	M20	26	12	M24	32	16	M27	32	12	M24	7/8"	26
350	14	77	36	12	M20	26	16	M20	26	16	M24	32	16	M30	36	12	M27	1"	32

* For flanges in cast or ductile iron 4 holes M16 and for flanges in steel 8 holes M16 on the same drilling circle.

DN	NPS	a	e	BS10-d			BS10-e			JIS2238 & JIS2239 5K			JIS2238 & JIS2239 10K			JIS2238 & JIS2239 16K		
				*Nb rods or Nb screw	ØV UNC	c	*Nb rods or Nb screw	ØV UNC	c	*Nb rods or Nb screw	ØV	c	*Nb rods or Nb screw	ØV	c	*Nb rods or Nb screw	ØV	c
25	1	32	--	4	1/2"	18	4	1/2"	18	4	M10	16	4	M16	24	4	M16	24
32/40	1 1/2	32	14	4	1/2"	18	4	1/2"	18	4	M12	18	4	M16	24	4	M16	24
50	2	43	18	4	5/8"	24	4	5/8"	24	4	M12	18	4	M16	24	8	M16	24
65	2 1/2	46	20	4	5/8"	24	4	5/8"	24	4	M12	18	4	M16	24	8	M16	24
80	3	46	20	4	5/8"	24	4	5/8"	24	4	M16	24	8	M16	24	8	M20	26
100	4	52	24	4	5/8"	24	8	5/8"	24	8	M16	24	8	M16	24	8	M20	26
125	5	56	26	8	5/8"	24	8	5/8"	24	8	M16	24	8	M20	26	8	M22	26
150	6	56	26	8	5/8"	24	8	3/4"	26	8	M16	24	8	M20	26	12	M22	26
200	8	60	28	8	5/8"	24	8	3/4"	26	8	M20	26	12	M20	26	12	M22	26
250	10	68	32	8	3/4"	26	12	3/4"	26	12	M20	26	12	M22	26	12	M24	32
300	12	77	36	12	3/4"	26	12	7/8"	26	12	M20	26	16	M22	26	16	M24	32
350	14	77	36	12	7/8"	26	12	7/8"	26	12	M22	26	16	M22	26	16	M30 x 3	36

* WAFER TYPE BODY AND LUGS WITH UNTHREADED HOLES :

Assembly by rods : number of nuts and washer = 2 x Number of rods (above)

Assembly by bolts : Number of nuts = Number of screws (above) and number of washer = 2 x Number of nuts

* LUG TYPE BODY :

Assembly by screws : Number of screw per face (above) and number of washer is the same

* DOUBLE FLANGE BODY :

Assembly by rods : number of nuts and washers = 2 x Number of rods (above)

Assembly by rods + central nut : Number of nuts = 2 x Number of rods (above)

Number of washers = 4 x Number of rods (above)

Number of thin nuts for central position = 1 x Number of rods (above)

** ASME / ANSI B16.5 Class 150 : **Standard** version : metric threading; UNC threading : please consult us.

Bolts and nuts

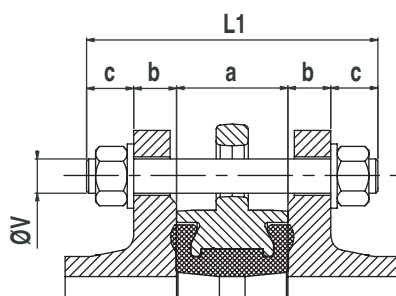

For wafer type and lugs with unthreaded holes ; assembly by rods :

L1 = a + 2(b+c)

- L1 = minimum length of rods
- a = width of the butterfly valve (face to face dimension)
- b = thickness of the flange (customer)
- c = thickness of washer + thickness of nut + exceeding length of the rod.

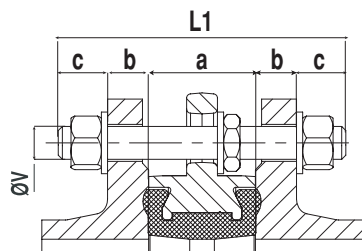

Mounting in case of downstream pipework dismantling (see page 8).
Use nuts with reduced face-to-face dimensions between the butterfly valve and the downstream flange.

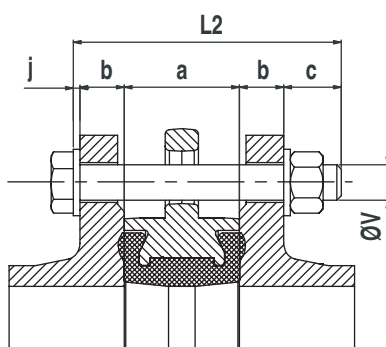

For wafer type and lugs with unthreaded holes ; assembly by bolts :

L2 = a + 2b + c + j

- L2 = minimum length under head of screw
- a = width of the butterfly valve
- b = thickness of the flange (customer)
- c = thickness of washer + thickness of nut + exceeding length of the rod
- j = thickness of washer at the head of the screw.

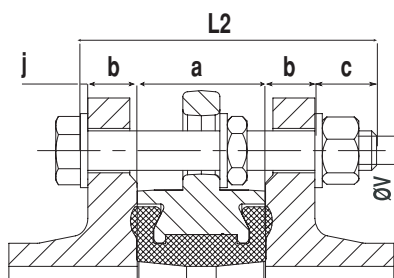

Mounting in case of downstream pipework dismantling (see page 8).
Use nuts with reduced face-to-face dimensions between the butterfly valve and the downstream flange.

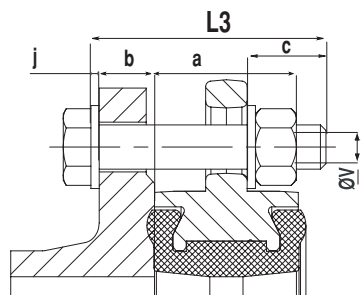

Version lug type with unthreaded holes, (permanent downstream dismantling) assembly by bolts :

L3 = a/2 + b + c + j

- L3 = minimum length under head of screw
- a = width of the butterfly valve (face to face dimension)
- b = thickness of the flange (customer)
- c = thickness of washer + thickness of nut + exceeding length of the rod
- j = thickness of washer under head of screw

Installation
• General remarks :

For safety reasons, the installation must take place under the supervision of authorised people taking account of local safety instructions and advice.

The handling of butterfly valves and their controls must be done by staff trained in all technical aspects of their operation.

Before installation the pipes must be depressurised and purged (empty of its fluid) in order to avoid any danger to the operator.

The pipe work must be correctly aligned so that no extra stress is exerted on the valve casing.

Check the compatibility of the connection flanges against the operating pressure : the PN number of the flanges must be greater or equal to the operating pressure.

The valve is a machined piece of equipment and must not be used to prise apart the flanges.

A mounting instruction specifying the installation characteristics and the commission of the Sylax 25-350 mm is available on our web site www.socla.com or on request by our sales department.

• Installation conditions :

It is recommended that the distances mentioned below be respected in order to prolong the life time of the valve.

Mounting the valve close to pipe work junctions places it in turbulent zones which increase its wear.

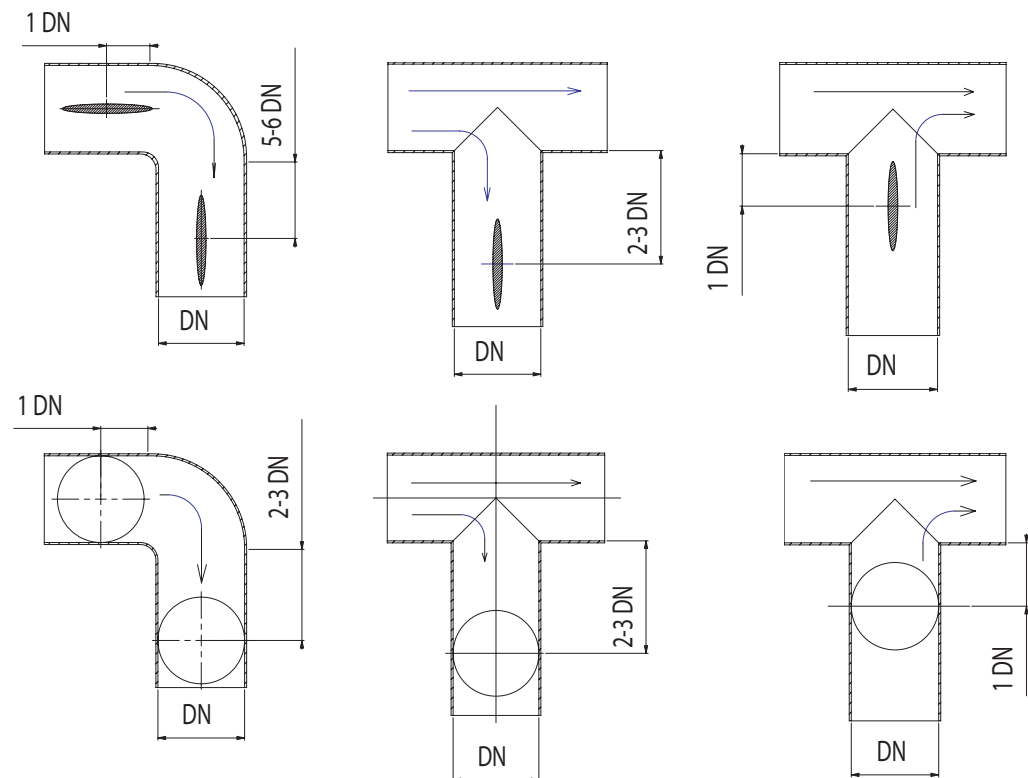

Socla can accept no responsibility for possible errors in catalogue, brochures and other printed material. Socla reserve the right to alter its products without notice. This also applies to products already agreed. All trademarks in this material are the property of the respective companies. All right reserved.

Socla sas

365 rue du lieutenant Putier
71530 VIREY LE GRAND
Postal address : CS 10273
71107 CHALON SUR SAONE Cedex

Tel : 33 3 85 97 42 52
Fax : 33 3 85 97 97 42
<http://www.socla.com>
e-mail : contact@socla.com