

# Technical data sheet

## Type 418 Non return valve System B

### Applications and special features



- Vertical ascending and horizontal position (position the ball housing above the axis of the pipe)
- Minimum head loss
- Silent, robust
- Non incrustating materials
- Closing system : ball lifted up by the liquid and guided to a lateral housing completely out of the way
- Sealing guaranteed by the coating of the ball.



### Technical description

DN "	mm	PN	PFA bar	PS - bar				Cat.	References	Vvs-nr
				L1	L2	G1	G2			
2	50	10/16	10	10	10	10	10	I	149B 3140	
2 <sup>1/2</sup>	65	10/16	10	10	10	10	10	I	149B 3141	
3	80	10/16	10	10	10	10	10	I	149B 3142	
4	100	10/16	10	10	10	10	10	I	149B 3143	
5	125	10/16	10	10	10	0,5	10	I	149B 3144	
6	150	10/16	10	10	10	0,5	10	I	149B 3145	
8	200	10	10	10	10	0,5	10	I	149B 3146	
10	250**	10	10	10	10	0,5	10	I	149B 2907	
12	300**	10	10	10	10	0,5	10	I	149B 2908	
14	350**	10	10	10	10	0,5	10	I	149B 2909	

\*\* Type 408

#### Important notice :

The indicated pressure for the different categories of fluids (L1/L2/G1/G2) is under no condition a guarantee of use. Therefore, it is essential to validate the use of products under given operating conditions.

- **Connection** : flanges drilled PN : see table
- **Permissible operating pressure PFA - water-** (for supply, distribution and disposal of water) : See table
- **Maximum permissible pressure PS - other mediums** : See table
- **θ** Mini -10°C  
Maxi. 80 °C
- **Mediums** : Thick liquids, viscous liquids, loaded liquids
- **Approvals** :   PED 97/23/CE  
CPR 305/2011/UE
- **International construction Standards** :  
CE Conformity Directive 97/23/CE  
CE Conformity Regulation 305/2011/UE EN12050-4 Standard  
Flange drilling according to EN1092-2  
Length according to EN558 series 48

### Overall dimensions

DN "	A mm	B mm	C mm	D mm	Weight kg
2	50	200	165	173	5,5
2 <sup>1/2</sup>	65	240	185	214	9,1
3	80	260	200	252	13,3
4	100	300	220	289	20,9
5	125	350	250	368	27,5
6	150	400	285	424	35,7
8	200	500	340	509	63,7
10**	250	600	400	593,5	128,9
12**	300	700	455	725,5	220,1
14**	350	875	505	820	345,6

\*\* Type 408

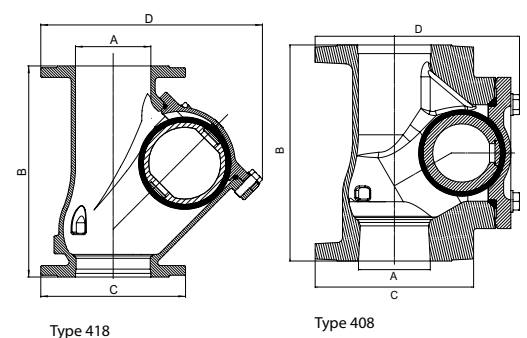

Type 418

Type 408

# Technical data sheet Type 418 - Non return valve

## Spare parts list and materials

Nb	Description	Materials	EURO	ANSI
1	CASING	Ductile iron + epoxy	EN-GJS-400.15	ASTM A 536 60-40-18
2	BALL DN 50 up to 100 DN up to 350	Aluminium + NBR Cast iron + NBR		
3	CAP	Ductile iron + epoxy	EN-GJS-400.15	ASTM A 536 60-40-18
4	SEAL	NBR		
5	SCREW-WASHER	Stainless steel	X5Cr-Ni18-10	AISI 304

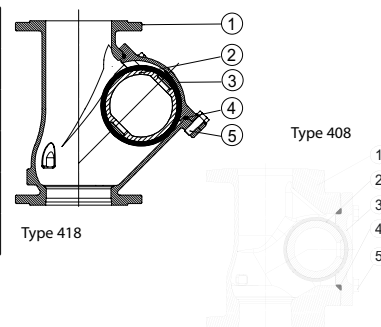

## Working principle

DN		Opening pressure in mm/CE		Kv	ζ
"	mm			m <sup>2</sup> /H	
2	50	25	near 0	71,5	1,95
2 1/2	65	30		171,5	0,97
3	80	160		217,5	1,38
4	100	160		319	1,57
5	125	170		744,9	0,7
6	150	200		1133,7	0,63
8	200	250		2766	0,33
10	250	180		2826	0,78
12	300	200		5228	0,48
14	350	220		6132	0,64

### Directions for use :

- Solid line : Valve completely open

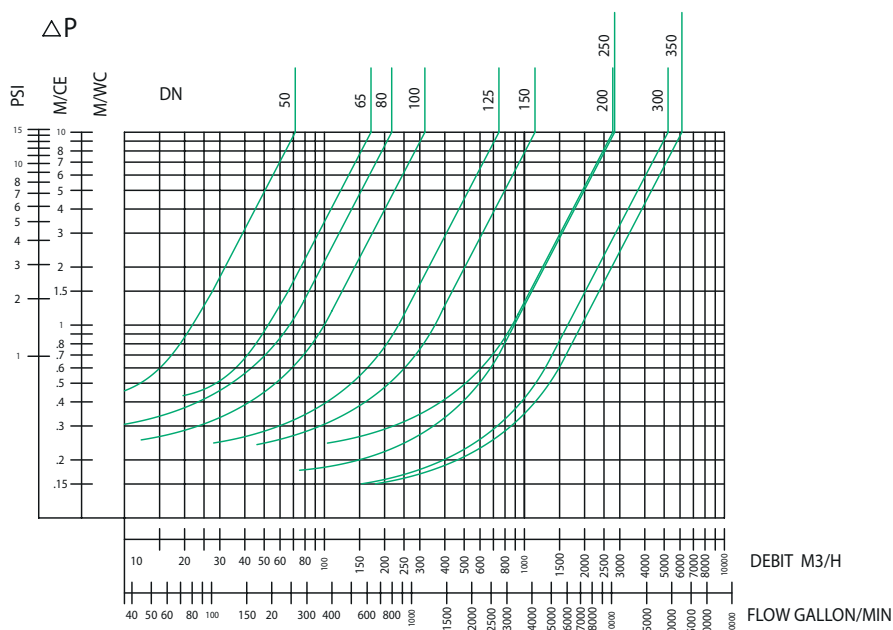

Socla can accept no responsibility for possible errors in catalogue, brochures and other printed material. Socla reserve the right to alter its products without notice. This also applies to products already agreed. All trademarks in this material are the property of the respective companies. All right reserved.

## Socla SAS

365 rue du lieutenant Putier  
71530 VIREY LE GRAND  
Postal address : CS 10273  
71107 CHALON SUR SAONE Cedex

Tel : 33 3 85 97 42 52  
Fax : 33 3 85 97 97 42  
<http://www.socla.com>  
e-mail: [commerfr@socla.com](mailto:commerfr@socla.com)