

BARRETTE RETTANGOLARI RETTIFICATE

RECTANGULAR GRINDING BAR

	INDICE - INDEX
COMPLETAMENTE IN METALLO DURO PER TAGLIO (COLTELLI - SPINE CENTRALI) ALL TUNGSTEN CARBIDE FOR CUTTER (CUTTING TOOL - CENTRE MANDREL)	PAG 2
COMPLETAMENTE IN ACCIAIO PER TAGLIO (COLTELLI - SPINE CENTRALI) SENZA COBALTO ALL HSS FOR CUTTER (CUTTING TOOL - CENTRE MANDREL) WITHOUT COBALT	PAG 3
COMPLETAMENTE IN ACCIAIO PER TAGLIO (COLTELLI - SPINE CENTRALI) 10% DI COBALTO ALL HSS FOR CUTTER (CUTTING TOOL - CENTRE MANDREL) WITH 10% OF COBALT	PAG 4
COMPLETAMENTE IN METALLO DURO (DIVISORI) ALL TUNGSTEN CARBIDE (PITCH TOOL)	PAG 5

PAG 2 : BARRETTE RETTIFICATE IN h6. ---- RECTANGULAR BAR GRINDING IN h6 .

* A richiesta. Se desiderate avere una nostra quotazione, vi preghiamo di stampare, compilare e spedirci questo disegno.

* On request. If you would like to receive our quotation: please, print the drawing, compile the list and send back us its.

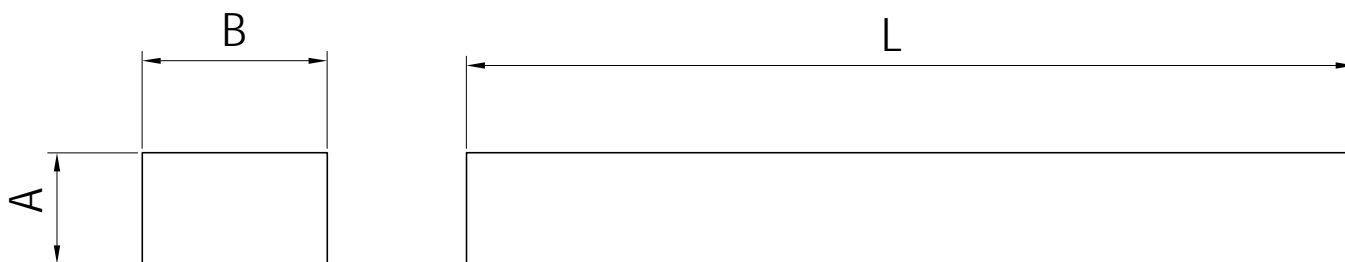

N° Pezzi N° Pieces	A ^{h6}	B ^{h6}	L

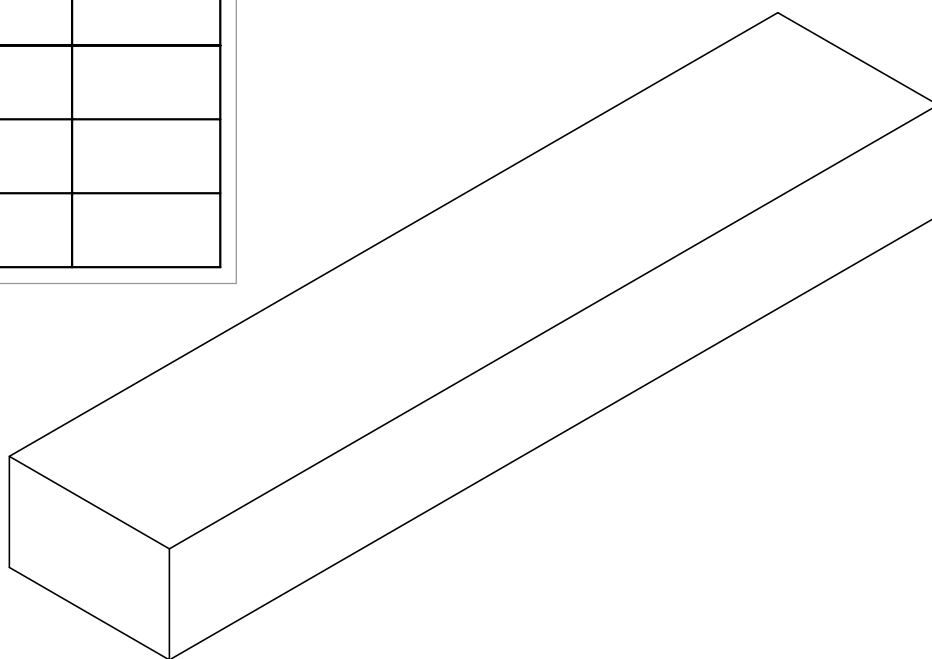

COMTECH S.R.L.

TECNOLOGIA DEI COMPONENTI
23819 PRIMALUNA (LECCO)
TEL. 0341 / 980377
FAX. 0341 / 983731
www.comtechtalia.it / com
E-mail: info@comtechtalia.it
info@comtechtalia.com

TO COMPILE BY:

DESCRIPTION:

CODE:

MATERIAL: Metallo Duro ---- Tungsten Carbide

MACCHINA:

COMPANY:

PAG 3 : BARRETTE RETTIFICATE IN h6. ---- RECTANGULAR BAR GRINDING IN h6 .

* A richiesta. Se desiderate avere una nostra quotazione, vi preghiamo di stampare, compilare e spedirci questo disegno.

* On request. If you would like to receive our quotation: please, print the drawing, compile the list and send back us its.

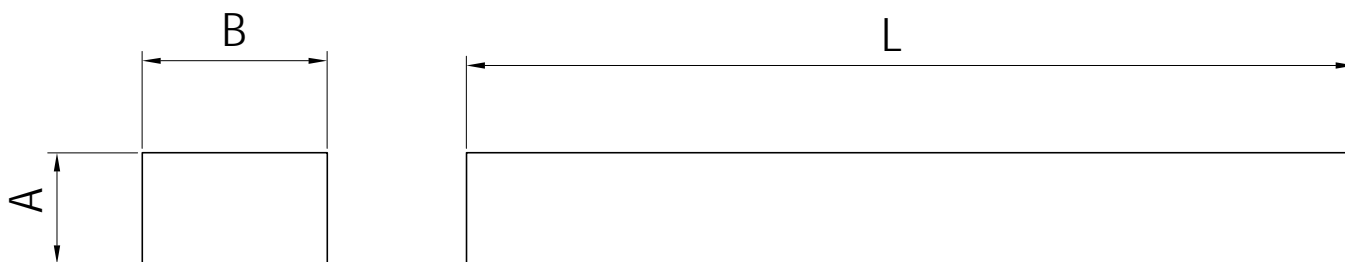

N° Pezzi N° Pieces	A ^{h6}	B ^{h6}	L

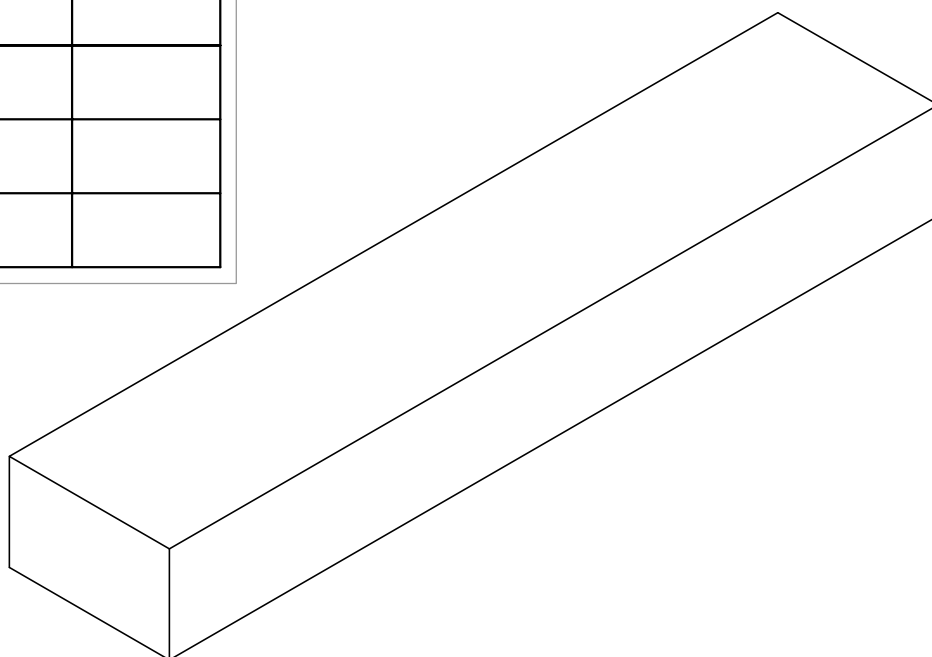

COMTECH S.R.L.

TECNOLOGIA DEI COMPONENTI

23819 PRIMALUNA (LECCO)

TEL. 0341 / 980377

FAX. 0341 / 983731

www.comtechtalia.it / com

E-mail: info@comtechtalia.it

info@comtechtalia.com

TO COMPILE BY:

DESCRIPTION:

CODE:

MATERIAL: Acciaio senza cobalto ---- H S S without cobalt

MACCHINA:

COMPANY:

PAG 4 : BARRETTE RETTIFICATE IN g14. ---- RECTANGULAR BAR GRINDING IN g14 .

* A richiesta. Se desiderate avere una nostra quotazione, vi preghiamo di stampare, compilare e spedirci questo disegno.

* On request. If you would like to receive our quotation: please, print the drawing, compile the list and send back us its.

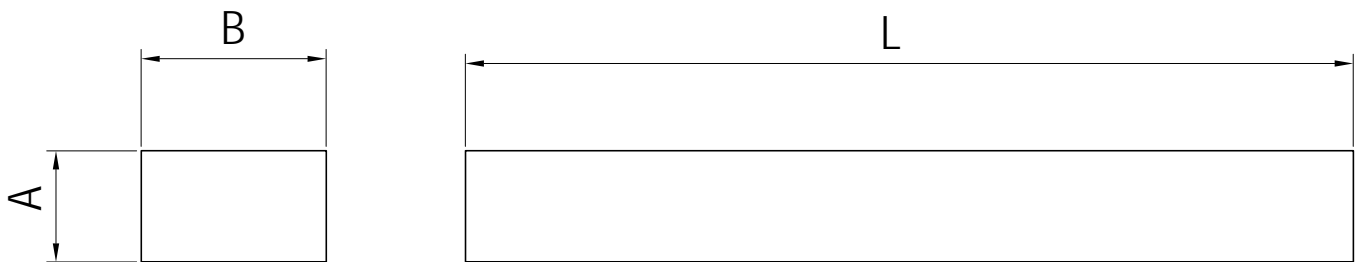

N° Pezzi N° Pieces	A g 14	B g 14	L

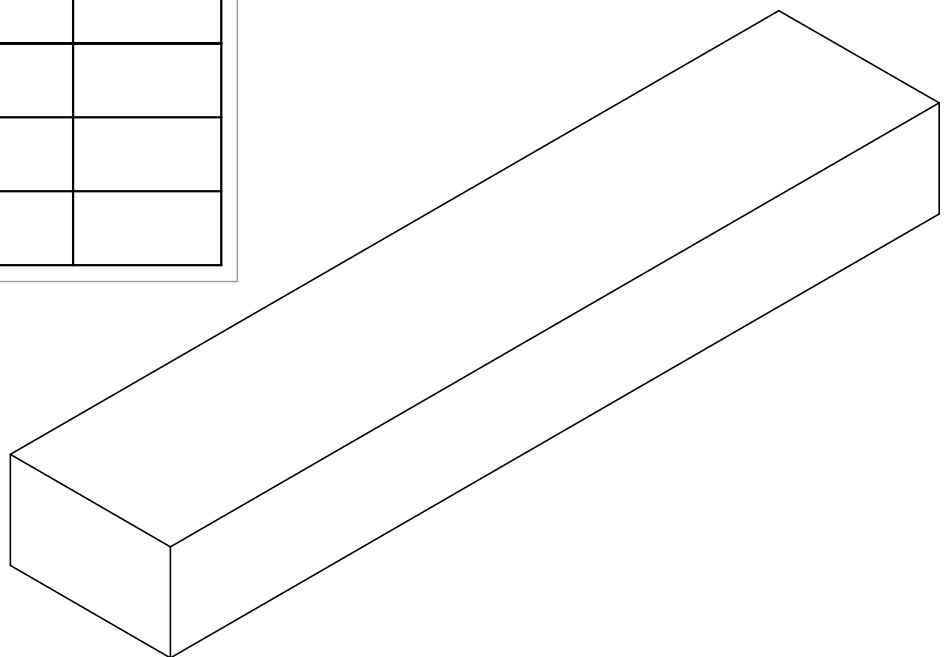

COMTECH S.R.L.

TECNOLOGIA DEI COMPONENTI
23819 PRIMALUNA (LECCO)
TEL. 0341 / 980377
FAX. 0341 / 983731
www.comtechtalia.it / com
E-mail: info@comtechtalia.it
info@comtechtalia.com

TO COMPILE BY:

DESCRIPTION:

CODE:

MATERIAL: Acciaio 10 % di cobalto ---- H S S with 10 % of cobalt

MACCHINA:

COMPANY:

PAG 5 : BARRETTE RETTIFICATE IN h6. ---- RECTANGULAR BAR GRINDING IN h6 .

* A richiesta. Se desiderate avere una nostra quotazione, vi preghiamo di stampare, compilare e spedirci questo disegno.

* On request. If you would like to receive our quotation: please, print the drawing, compile the list and send back us its.

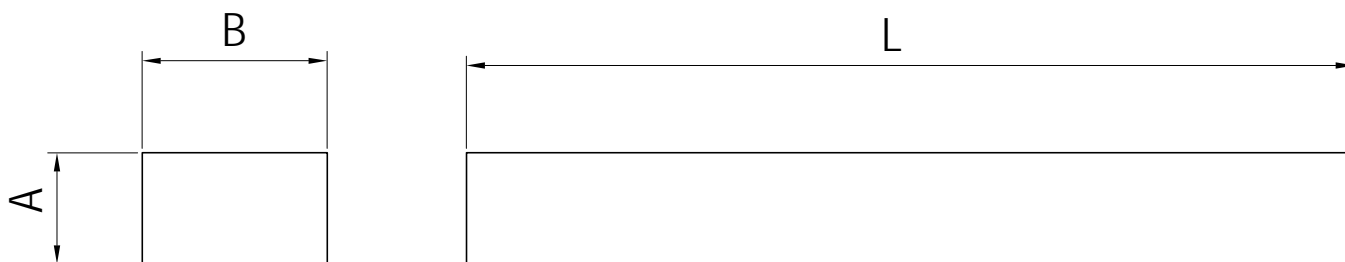

N° Pezzi N° Pieces	A ^{h6}	B ^{h6}	L

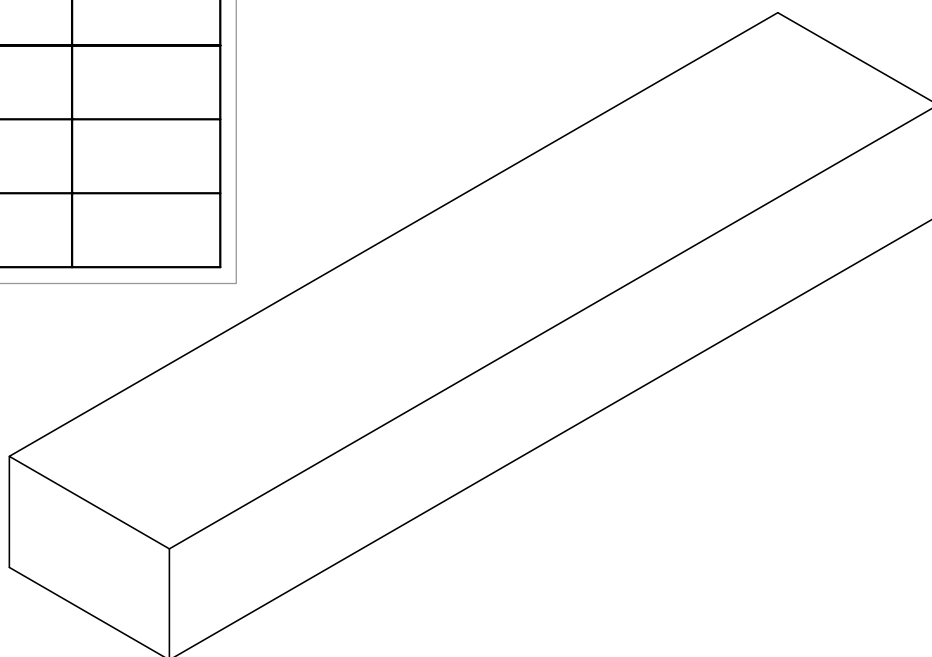

<p>COMTECH <small>S.R.L.</small></p> <p>TECNOLOGIA DEI COMPONENTI 23819 PRIMALUNA (LECCO) TEL. 0341 / 980377 FAX. 0341 / 983731 www.comtechtalia.it / com E-mail: info@comtechtalia.it info@comtechtalia.com</p>	DESCRIPTION:
	CODE:
	MATERIAL: Metallo Duro --- Tungsten Carbide
	MACCHINA:
	COMPANY:
TO COMPILE BY:	