

Raw Material Processing

by:

Christopher Messina
RAD-CON, Inc.
13001 Athens Ave., Suite 300
Cleveland, OH 44107, USA
www.RAD-CON.com

Fastener makers increase margins and quality control by taking ownership of the spheroidize annealing process.

Over the past decade, more and more fastener manufacturers have pulled in spheroidize annealing as a core process to profitable fastener manufacturing. Advancements to spheroidize annealing process control have allowed ever smaller fastener companies to justify bringing this critical step in-house, realizing not only savings on the outside processing cost, but also returning benefits to their downstream processes.



The Business Case

For the medium-sized fastener manufacturer (less than 1000 tons per month), economics dictate strong consideration to bringing the spheroidize annealing process in-house. Such companies are paying a premium over raw hot-rolled wire rod of around US\$150/ton or US\$1,800,000/year for the 1000 ton per month producer. Considering all-in running costs of utilities and labor are ~US\$30/ton using today's latest annealing technology, an ROI can be achieved typically in less than two years for even the smallest of the medium-sized fastener makers.

100% hydrogen in 2005 has transformed the annealing process for wire rod.

Now, both decarburization and surface cleanliness are under complete control in the hydrogen annealing process, producing surface results that are superior in every way to roller hearths that use a carbonaceous atmosphere. And using automated hydrogen atmosphere control with process feedback, the hydrogen consumption is turned off when the process no longer needs it for decarburization protection—the result is the per-ton utility cost using today's hydrogen

To Anneal or Not Anneal? That is the Question

“But it's not our core business.” Or is it? Consider this. Every inch/centimeter of the processed steel turns into the product. Therefore, product quality depends on consistency throughout each coil—coils that are processed in batch, but only tested on the ends. All the SPC charts and Six-Sigma reporting does not change the fact that much of today's wire is processed using 30+ year old technology, where consistency of mechanical properties and surface quality throughout the coils are just not as good as that processed with today's technology. Even if rejects are not an issue, die life costs in downstream cold forming operations are impacted by the consistency of this outside process.

Enter Hydrogen Annealing

The consistency of spheroidization throughout each coil produced by superior convection using a modern bell-type hydrogen annealer are well known. And 100% hydrogen annealed material is touted to provide superior surface finish. However, when uncontrolled hydrogen entered the wire annealing market in the 1990s, decarburization of the wire surface was the issue. It is for this reason some bell furnace suppliers are still promoting nitrogen, and also that a certain roller hearth furnace gained acceptance (mostly in Asia).

However, RAD-CON's introduction of AC/APEX™ for



EMPHASIS: Heat Treating

bell furnace is nearly half that of the roller hearth using carbonaceous atmosphere. Using highly reactive hydrogen and automating the atmosphere control into a robust process able to deal with variable incoming wire conditions dynamically, has allowed fastener makers new to annealing to control their own raw material quality and tune it to their downstream needs.

Bells Have Been a Mainstay

For decades, the bell-type furnace has been a standard for the heat treatment process of spheroidize annealing medium-carbon alloy steels for cold heading quality (CHQ), which is a key step in preparing wire rod for the fastener manufacturing process. The advantages include a well controlled convection system leading to product uniformity—of critical importance to the spheroidize annealing cycle. A sealed inner cover along with a protective atmosphere inhibits decarburization. The nature of the bell furnace concept results in efficient use of the furnace chamber space, resulting in low atmosphere and fuel consumption. The furnace can be configured for a single stack of coils or for multiple stacks under one inner cover.

Early bell furnace designs used nitrogen as the protective atmosphere for annealing wire rod. The inert nitrogen gas displaces and dilutes O₂, CO₂ and H₂O to levels that minimize the decarburization of the wire rod surface—the bane of fastener manufacturing. Depending on the nature of the sealing system, and other process factors, sometimes an additive gas is employed.

Using Hydrogen to Spheroidize Anneal Wire Rod...

...*Very short cycle times.* The modern bell-type hydrogen annealing system shortens the cycle in every segment: oxide reduction, soaking, spheroidizing and cooling. Closed-loop atmosphere control (e.g., patented RAD-CON AC/APEX) uses the hydrogen to minimize the oxide reduction step, in contrast to long dew point holds in conventional equipment. The soaking is shortened as the convection system drives heat into the charge much faster. Spheroidizing is shortened due to the tight temperature uniformity throughout the charge. And, removal of the heat from the charge is also accelerated.

Typical Performance Difference

	Conventional/Nitrogen	Hydrogen
Wire Rod	JIS SCM435 (AISI 4140), 13 mm (1/2")	
Charge Weight	20 t (22 USt)	30 t (33 USt)
Cycle Time (load to unload)	30h-40h	19 h
Spheroidization		≥ 90%

...*Unprecedented convection.* The convection flow of today's hydrogen annealing equipment is 5+ times the flow of the advanced systems of the 1980s, and 10 times some of the conventional nitrogen annealers in use today throughout the world. The higher convection flow along with the properties of hydrogen itself, substantially increase the rate at which heat is delivered to the charge. This convection also maintains tight

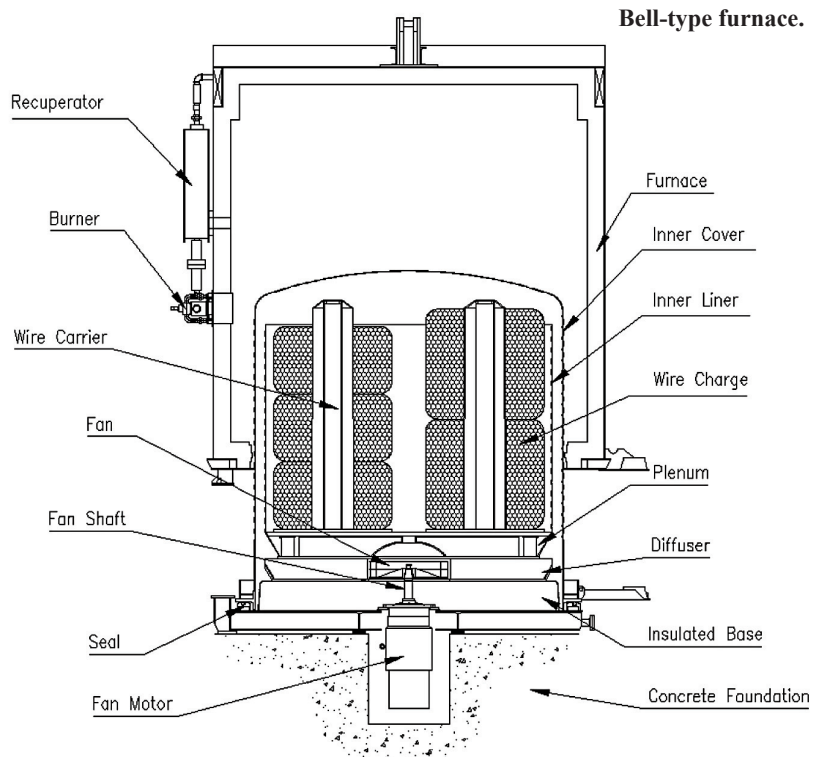

uniformity through the critical spheroidizing segment. With the temperature differential throughout the charge stabilized at $\pm 5^{\circ}\text{C}$ (9°F) or better, the time the furnace must spend in the spheroidizing segment is vastly reduced. When the uniformity is not so tight as in the case of a less sophisticated furnace, additional furnace time must be expended as each part of the disparate charge passes through the spheroidizing window at different times. Any attempts to shorten this segment beyond the capabilities of the equipment risks spoiled spheroidization in some parts of the charge.

Convection Flows, 1980s-present

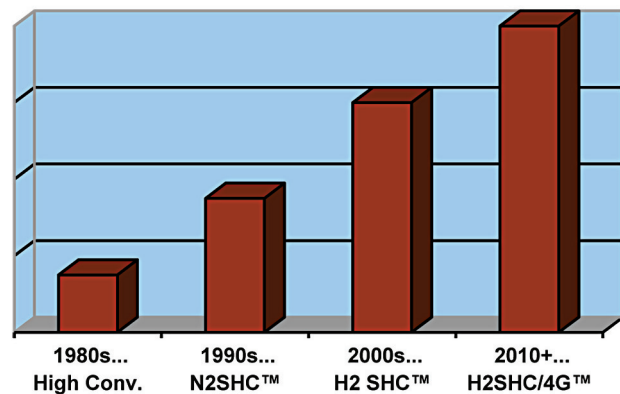

...*Surface quality control.* Uncontrolled, hydrogen can cause decarburization, which is precisely why a proper atmosphere system (e.g., patented RAD-CON AC/APEX) must be used to assure repeatable surface quality results when annealing wire rod. Hydrogen is a reactive gas, so unlike nitrogen, it does not displace contaminants, it reduces them. The advantage of the hydrogen is that it can quickly reduce the oxides inherent at the surface of the wire and entrained in

Raw Material Processing ...continued

the coatings. It is vital that the reduction process be complete below the temperatures at which decarburization can occur. Of practical importance are the variable conditions of the incoming wire rod due to differences in sources, processing and storage. A closed-loop atmosphere control system accurately and repeatedly senses and adjusts cycle after cycle to compensate, which is the essence of the AC/APEX patent.

The other huge advantage of hydrogen is complete avoidance of soot deposition—a problem encountered by those systems using hydrocarbon additives including endothermic atmospheres used by roller hearth furnaces. Downstream clean and coat operations are more efficient and effective after processing with hydrogen, requiring much simpler systems than those that need to deal with surface carbons.

...Lower Running Costs. Fuel, electricity, hydrogen and nitrogen are all optimized by the modern hydrogen system. The shorter cycle saves fuel. Less furnace time means lower thermal losses. Also, today's direct-fired burners with recuperation are more efficient than traditional radiant tubes. The higher flow hydrogen convection system effectively distributes the heat concentrated from these direct-fired burners.

Think Outside the Box

Short cycles are not the only reason for using hydrogen bell-type annealing. Shorter cycles have been the boast of certain roller hearth furnaces. And it is true that these furnaces,

married with a CO/CO₂ control system, have been able to provide closed-loop atmosphere control with decent quality results. However, the hydrocarbon gas feedstock for the endothermic atmosphere generator makes the atmosphere used in these furnaces expensive (and this atmosphere too is combustible). Considering generator heating and feedstock, it requires one part natural gas to make only two parts of endothermic gas. The empty space in the box-type work chamber leads to high atmosphere consumption, further exacerbating the high atmosphere and purging costs. A survey of installations in Asia has shown running costs to be 1½ to 2 times that achieved by today's hydrogen bell-type annealers. And since the quality differences lean towards hydrogen, the justification for this type of furnace is confined to saving a few crane lifts, against higher capital costs and significantly higher utility bills.

www.RAD-CON.com

FTI

Company Profile:

RAD-CON is a manufacturer of new bell-type annealing furnace equipment and a provider of systems to help existing annealing facilities operate better by adding new batch annealing capacity for high-quality products. Offered are 100% hydrogen bell-type annealing furnaces and complete turnkey plants. RAD-CON optimizes existing annealing operations by increasing throughput without adding furnaces, lowering operating costs via better scheduling and improving annealed quality. www.RAD-CON.com

FAR
BOLOGNA
ITALY

TUV
SUD

S.r.l.

SINCE
1957

We manufacture
BLIND RIVETS
BLIND RIVET NUTS
and **TOOLS**

FAR S.r.l.
Via Giovanni XXIII, 2 - Fraz. Quarto Inferiore - 40057 Granarolo Emilia - Bologna - Italy

Ph: +39 - 051 6009511
Fax: +39 - 051 767443
e-mail: commerciale@far.bo.it

Export Dpt.
Ph: +39 - 051 6009591
Fax: +39 - 051 768284
e-mail: export@far.bo.it

MADE IN ITALY

> web: www.far.bo.it