

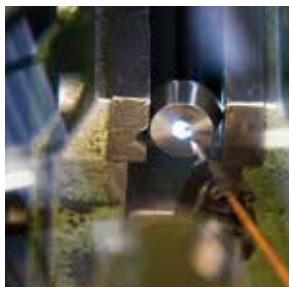

DEFREMM

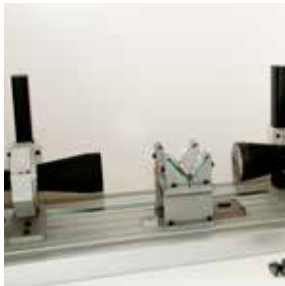

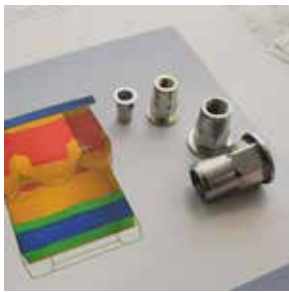



It's **the finer detail** that makes a product great

— made in Italy —



DEFREMM

PROFILO AZIENDALE

Fondata nel 1980, **DEFREMM S.P.A.** deve le sue origini all'azienda Minuterie Metalliche G. Molinari nata nel 1962 e inizialmente orientata alla produzione di rivetti a strappo.

Si è successivamente specializzata nello stampaggio a freddo di particolari speciali realizzati in conformità alle specifiche tecniche ed ai disegni del cliente e nella produzione di rivetti tubolari filettati.

DEFREMM propone al mercato soluzioni versatili di elevata tecnologia e massima affidabilità esportando circa il 60% della produzione.

I principali settori di destinazione sono: automotive, fasteners, elettrodomestici, idraulica, serramenti e costruzioni meccaniche.

COMPANY PROFILE

Founded in 1980, **DEFREMM S.P.A.** has its roots in the company Minuterie Metalliche G. Molinari founded in 1962 which initially focused on manufacture of blind rivets.

The company went on to specialise in cold forging small parts to the technical specifications and drawings of customers as well as producing threaded tubular rivets.

DEFREMM offers the market high tech versatile solutions with maximum reliability and currently exports about 60% of production.

The main sectors we manufacture for: automotive, fasteners, domestic appliances, fittings for plumbing, windows and doors and mechanical construction.

**FONDATA NEL 1980, DEFREMM S.P.A.
DEVE LE SUE ORIGINI ALL'AZIENDA MINUTERIE METALLICHE G. MOLINARI NATA NEL 1962
FOUNDED IN 1980, DEFREMM S.P.A.
HAS ITS ROOTS IN THE COMPANY MINUTERIE METALLICHE G. MOLINARI FOUNDED IN 1962**



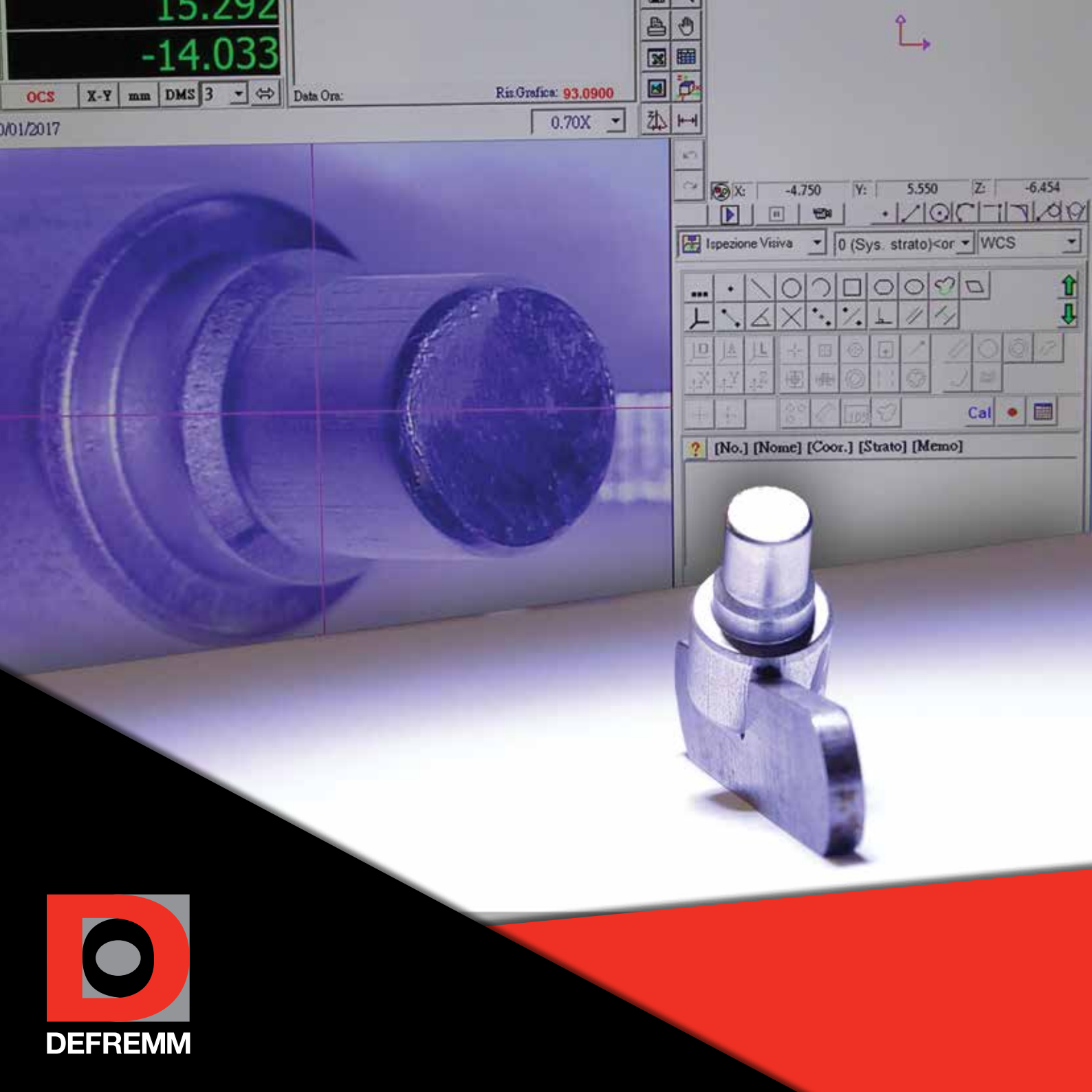

DEFREMM

QUALITÀ

CERTIFICATI

ISO TS 16949 ottenuto nel 2003

QS9000 ottenuto nel 1998

ISO 9001 ottenuto nel 1994

VISION

Affermarsi come partner competente ed affidabile in grado di fornire prodotti innovativi volti a soddisfare le esigenze del cliente, nel rispetto dei requisiti di legge vigenti ed applicabili.

MISSION

Sviluppare prodotti di qualità e una professionalità al servizio del cliente che accrescano le opportunità e portino ad una crescita di valore nel tempo.

OBIETTIVI

- Miglioramento continuo
- Soddisfazione del cliente
- Sviluppo di nuovi mercati e di nuovi segmenti di mercato
- Crescita in termini di valore
- Crescita in termini di professionalità e di competenze
- Efficienza nella gestione dei processi
- Acquisizione continua di nuovi clienti
- Ottimizzazione delle performances dei fornitori

RESPONSABILITA' SOCIALE E AMBIENTALE

Operare nel rispetto dei criteri e delle normative di sicurezza a tutela della salute dei dipendenti e della salvaguardia dell'ambiente.

QUALITY

CERTIFICATIONS

ISO TS 16949 in 2003

QS9000 in 1998

ISO 9001 certified since 1994

VISION

We aim to consolidate our reputation as a reliable partner supplying innovative products to satisfy customer requirements in full compliance with current legislation.

MISSION

Develop quality products and professional customer care to create opportunities and increase value over time.

OBJECTIVES

- Continuous improvement
- Customer satisfaction
- Develop new markets and market segments
- Growth in terms of value
- Increase professionalism and competence
- Efficiency in process management
- Continually win new customers
- Optimise supplier performance

SOCIAL AND ENVIRONMENTAL RESPONSIBILITY

We comply with health and safety requirements and standards in order to protect the welfare of our employees and safeguard the environment.

ISO TS 16949 IN 2003

QS9000 IN 1998

ISO 9001 IN 1994



ISO/TS 16949



DEFREMM

PROCESSI INTERNI

Sulla base della richiesta del cliente si effettuano analisi tecniche di fattibilità per lo **sviluppo di soluzioni innovative**.

Si realizzano internamente la progettazione e lo sviluppo delle attrezzature di produzione per il lancio della campionatura iniziale.

La successiva standardizzazione del processo produttivo avviene attraverso moderni impianti multi-stazioni per lo stampaggio a freddo ad elevata affidabilità e produttività con fasi di lavorazioni interamente monitorate.

INTERNAL PROCESSES

At the request of our customers we carry out technical feasibility studies to **develop innovative solutions**.

Machine tools are designed and developed in house for production of the initial samples.

Subsequent standardisation of manufacturing for mass production is achieved with state of the art machines. This highly efficient and reliable multistage cold forging machinery is monitored at every stage of the production process.

**SULLA BASE DELLA RICHIESTA DEL CLIENTE
SI EFFETTUANO ANALISI TECNICHE DI FATTIBILITÀ PER LO SVILUPPO DI SOLUZIONI INNOVATIVE.
AT THE REQUEST OF OUR CUSTOMERS
WE CARRY OUT TECHNICAL FEASIBILITY STUDIES TO DEVELOP INNOVATIVE SOLUTIONS.**





DEFREMM

LAVORAZIONI COMPLEMENTARI

Vengono eseguite lavorazioni complementari quali ripresa, foratura, filettatura, tornitura, trattamenti di lavaggio e ricottura per distensione.

Si dispone di impianti per la selezione dimensionale, rilevazione di corpi estranei e cricche tramite fotocamere digitali o correnti parassite, garantendo la totale conformità dei prodotti forniti.

Il confezionamento viene eseguito in accordo alle specifiche esigenze di ogni singolo cliente.

COMPLEMENTARY PROCESSING

We also carry out complementary processing such as recovery, punching, threading, turning, washing and annealing by stress relieving.

There are systems for size selection and detecting foreign bodies using digital cameras while cracks are detected using eddy currents. This guarantees absolute compliance of all products supplied.

Packaging is in accordance with the specific requirements of each individual customer.

**GARANTENDO LA TOTALE CONFORMITÀ DEI PRODOTTI FORNITI
THIS GUARANTEES ABSOLUTE COMPLIANCE OF ALL PRODUCTS SUPPLIED**





DEFREMM

PROCESSI ESTERNI

DEFREMM collabora con fornitori certificati e selezionati in diversi paesi per gli approvvigionamenti di filo in acciaio a basso e medio tenore di carbonio, acciaio inossidabile e leghe in alluminio, rame e ottone.

DEFREMM si avvale di partner qualificati per trattamenti speciali di tempra, bonifica e zincatura trivalente con caratteristiche, spessori e resistenza in nebbia salina in accordo alle normative di riferimento ed alle singole richieste del cliente.

EXTERNAL PROCESSES

DEFREMM works together with certified selected suppliers in a number of countries for provisioning of low and medium carbon steel wire, stainless steel and aluminium, copper and brass alloys.

DEFREMM avails of qualified partners for special tempering, hardening and trivalent zinc-plating treatments with characteristics, thicknesses and resistance to salt spray compliant with reference standards and any specific customer requests.

DEFREMM COLLABORA CON FORNITORI CERTIFICATI E SELEZIONATI IN DIVERSI PAESI
DEFREMM WORKS TOGETHER WITH CERTIFIED SELECTED SUPPLIERS IN A NUMBER OF COUNTRIES





DEFREMM

INDUSTRIA 4.0

L'obbiettivo **DEFREMM** è diventare leader Industria 4.0, utilizzando tecnologie digitali innovative per la governance aziendale.

La comunicazione e cooperazione fra persone, oggetti, macchine, strumenti, sistemi logistici e produttivi ci portano ad una convergenza tra processi produttivi ed informativi.

Così si crea una interconnessione ad ogni livello che facilita la condivisione dei dati per una maggiore flessibilità, velocità, positività e qualità lungo tutta la value chain.

INDUSTRY 4.0

We have now set our sights on becoming an Industry 4.0 leader, utilising smart manufacturing technologies for the governance of our business.

Digital manufacturing is where our new state of the art production management and process monitoring systems network production lines, warehouse and administration giving us an IT/OT convergence.

This interconnected systems interfacing at every level yield a constant flow of data and allow for interconnection and sharing all along the value chain.

L' OBIETTIVO DEFREMM È DIVENTARE LEADER INDUSTRIA 4.0
WE HAVE NOW SET OUR SIGHTS ON BECOMING AN INDUSTRY 4.0 LEADER



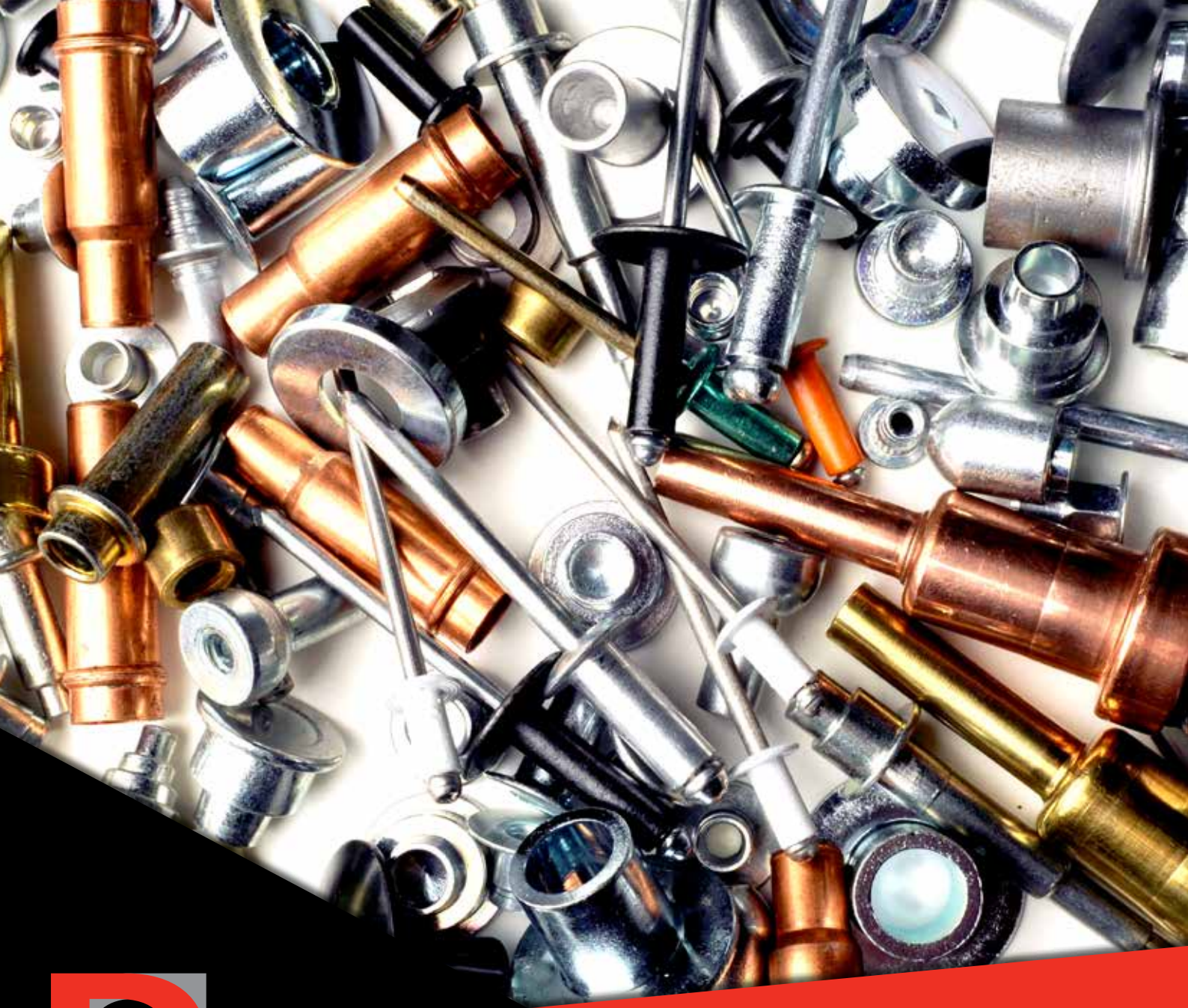

DEFREMM

PRODOTTI SPECIALI

DEFREMM dispone di moderni impianti per lo stampaggio a freddo da filo a più stazioni con potenze fino a 1500 KN, dotati di aggiornati sistemi di controllo della produzione e complete di tutti gli asservimenti necessari per garantire un elevato standard qualitativo del prodotto.

Essi consentono lavorazioni con fili di vari materiali da 3 a 18,50 mm di diametro che permettono di realizzare particolari da 2,5 a 90 mm di lunghezza.

Il processo produttivo è completato con l'ausilio di macchine per ripresa, rullatrici, maschiatrici e macchine per l'assemblaggio dei rivetti a strappo.

SPECIAL PRODUCTS

DEFREMM has state of the art multistage wire cold forging machinery with power up to 1500 KN, fitted with up to the minute production control systems and all that is required to ensure high product quality.

Wire made of different materials can be processed in diameters from 3 to 18,50 mm making it possible to produce parts from 2,5 to 90 mm in length.

The manufacturing process is completed with machines for reworking, rolling, tapping and assembly of blind rivets.

**LAVORAZIONI CON FILI DI VARI MATERIALI DA 3 A 18,50 MM DI DIAMETRO CHE PERMETTONO DI REALIZZARE PARTICOLARI DA 2,5 A 90 MM DI LUNGHEZZA.
CAN BE PROCESSED IN DIAMETERS FROM 3 TO 18,50 MM MAKING IT POSSIBLE TO PRODUCE PARTS FROM 2,5 TO 90 MM IN LENGTH.**





h 37,80 mm



h 38,80 mm

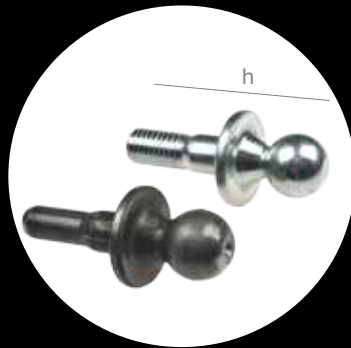

h 44,70 mm



h 38,20 mm



Ø 15,50 mm | h 14,50 mm

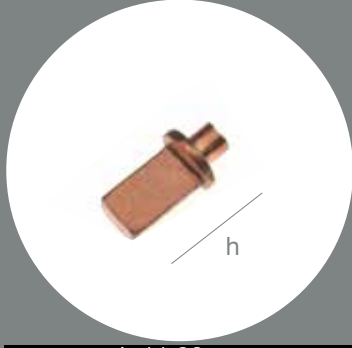

h 11,90 mm

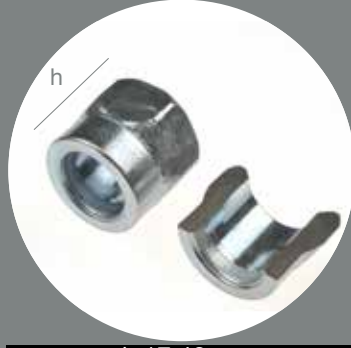

h 17,40 mm



h 26,50 mm



h 30,30 mm

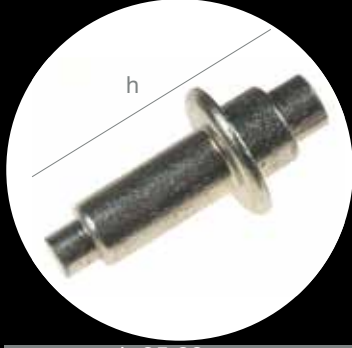

h 25,00 mm



h 14,00 mm



h 46,30 mm



h 12,60 mm



h 14,30 mm

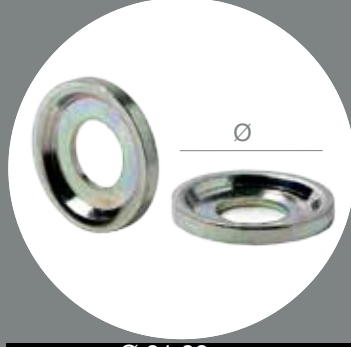

Ø 21,00 mm



h 20,50 mm



h 21,70 mm



h 20,65 mm



h 18,10 mm



h 23,90 mm



Ø1 9,00 mm | Ø2 4,50 mm



h 16,10 mm



Ø 16,20 mm



h 26,50 mm



h 19,10 mm



h 29,20 mm



h 27,30 mm



h 20,20 mm

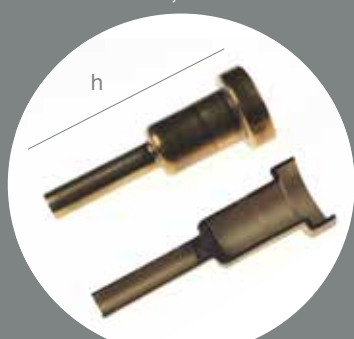

h 52,40 mm



h 23,30 mm



Ø 13,00 mm



Ø 16,00 mm



h 15,00 mm



h 20,00 mm

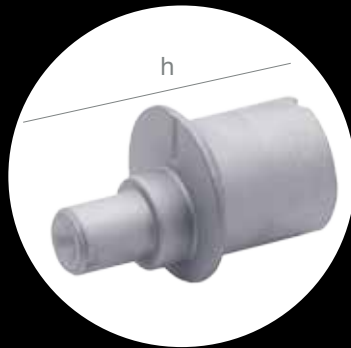

h 15,60 mm



h 8,50 mm



h 21,00 mm



h 7,00 mm

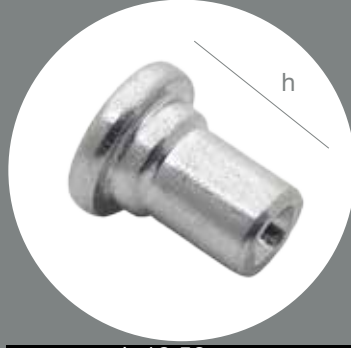

h 10,50 mm



Ø 22,00 mm

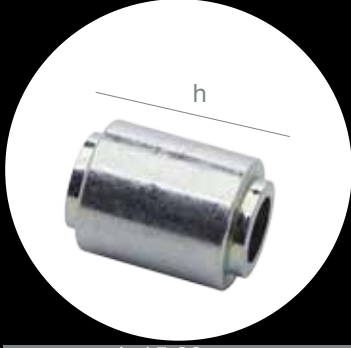

h 15,00 mm

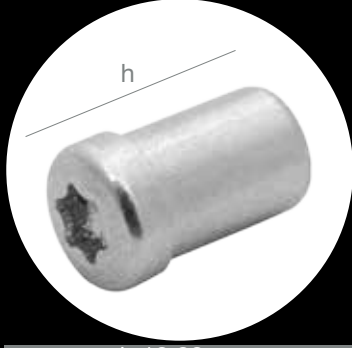

h 12,00 mm



h 17,00 mm



h 15,00 mm



h 9,00 mm



Ø 21,00 mm



h 31,00 mm



h 32,00 mm



h 13,00 mm



h 28,50 mm



h 32,00 mm



Ø 17,00 mm



Ø 27,80 mm

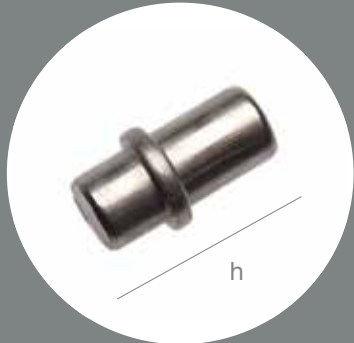

h 10,50 mm



h 10,90 mm

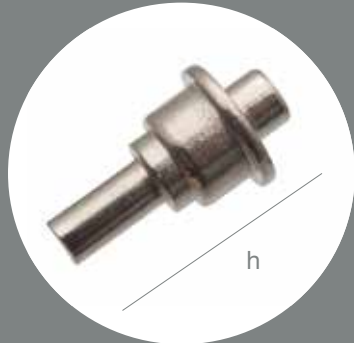

h 20,00 mm

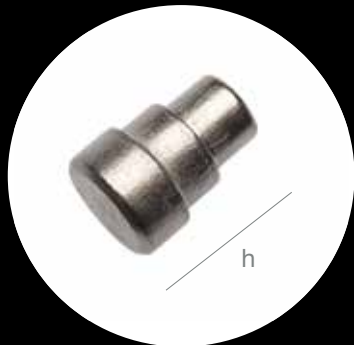

h 10,10 mm



Ø 19,90 mm

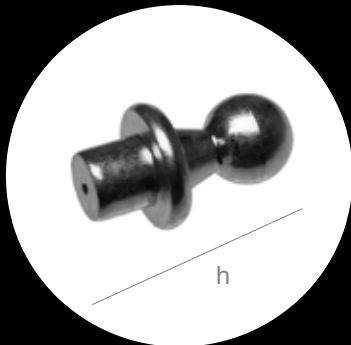

h 23,50 mm



h 32,00 mm



Ø 16,70 mm



Ø 19,90 mm

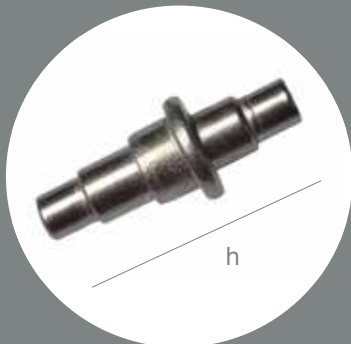

h 22,70 mm

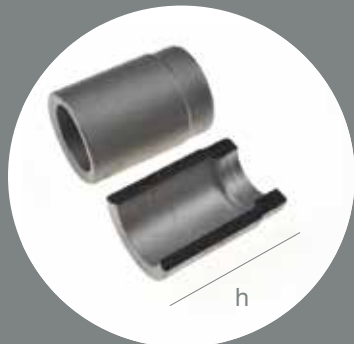

h 30,90 mm



DEFREMM

RIVETTI TUBOLARI FILETTATI

I rivetti tubolari filettati, prodotti secondo quanto riportato nel catalogo specifico, sono dispositivi di fissaggio composti da un corpo con parte interna filettata e servono per effettuare ancoraggi su spessori sottili accessibili anche solo da un parte.

A deformazione avvenuta, la parte filettata funge da supporto per ogni necessità di applicazione mediante l'avvitatura di parti mobili.

THREADED TUBULAR RIVETS

Threaded tubular rivets, produced according to the specifications in the special catalogue, are fastening devices made up of a body threaded on the inside and are used for fixing fine thicknesses even if accessible from only one side.

Once deformation has taken place, the threaded part acts as a support for all applications by allowing loose parts to be screwed together.



S1 M STC
S2 M STC



S1 M SFL
S2 M SFL



S1 M LTC



S1 M LFL



S1 M STS



S1 M TEFL



S1 M ETC



S1 M EFL
S2 M EFL



S1 M STC C



S1 M SFL C



S1 M TETC C



S1 M TEFL C



I1 M STC
I2 M STC



I1 M SFL
I2 M SFL



I1 M ETC



I1 M EFL



DEFREMM

RIVETTI A STRAPPO

I rivetti a strappo, prodotti secondo quanto riportato nel catalogo specifico, sono dispositivi di fissaggio composti da un corpo tubolare accoppiato ad un mandrino con tacca di rottura predeterminata.

Sono utilizzati nei più svariati settori per assemblare due o più elementi anche in presenza di un foro cieco.

BLIND RIVETS

Blind rivets, manufactured in compliance with technical specifications in the special catalogue, are fastening devices made up of a tubular body coupled with a mandrel with a preset breaking notch.

They are used in a wide range of sectors to assemble two or more components, even where there are blind holes.



AST



ASF



ASL



ASG



AIT



AST...FIOR



SST



SSF



IIT...CRU



AST...MG



ASL...MG



SST...MG

www.defremm.it

It's **the finer detail** that makes a product great.

www.defremm.it

It's **the finer detail** that makes a product great.

www.defremm.it

It's **the finer detail** that makes a product great.

www.defremm.it

Will be your **icing on the cake.**

www.defremm.it

Meeting **special fasteners** needs.

www.defremm.it

www.defremm.it

Proudly **made in italy**

www.defremm.it

It's **the finer detail** that makes a product great.

www.defremm.it

It's **the finer detail** that makes a product great.

DEFREMM

Honoured to be **part of your products**

DEFREMM
www.defremm.it

Honoured to be **part of your products**

DEFREMM
www.defremm.it

www.defremm.it

Always up to the challenge.

DEFREMM

www.defremm.it

The real difference is inside

Honoured to be **part of your products**

DEFREMM

www.defremm.it

The real difference is inside

Honoured to be **part of your products**

DEFREMM

CONSTANTLY EVOLVING...



DEFREMM



Via Goito, 6
23900 Lecco (LC)
ITALY

TEL. (+39) 0341 251410
FAX (+39) 0341 251411

www.defremm.it