



weighpack

Packaging Solutions

Form-, Fill & Sealing Machine type WPVF270





weighpack

Packaging Solutions

Vertical Form-, Fill & Sealing Machine type WPVF270

General characteristics:

- Sealing system with 3 independent movements, for a better sealing and to prevent the damage of the cutting knife.
- Automatic end of film detection system with machine pause when the film-reel is empty.
- Bag length measuring system by encoder.
- Sealing system by impulse sealing (PE up to 120 micron).
- Motorized film-reel unwinding system.
- Main structure made of painted steel.
- Interchangeable forming tube.
- Self-centring reel holding unit.
- Integrated electrical cabinet.
- Motorized film-pulling unit.
- Sealing bar safety device.
- Controlled by PLC.
- CE certification.

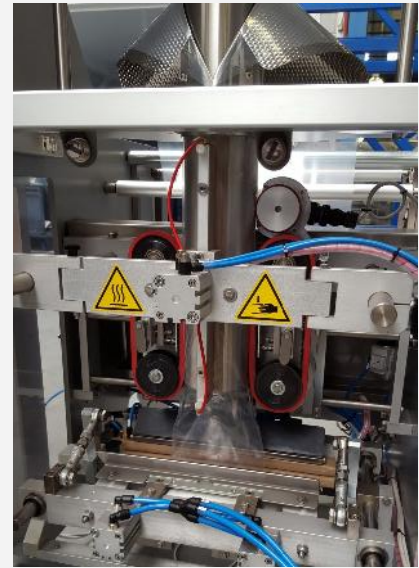

Technical characteristics:

Min. bag length : 50 mm
Max. bag length : 300 mm
(600 mm at double sealing cycle)
Min. bag width : 60 mm
Max. bag width : 235 mm
Max. film reel diameter : 400 mm
Max. film reel width : 510 mm

Max. external forming tube : 155 mm
Capacity : Up to 30 bags/min.
Weight : 380 kg
Power supply : 3x400VAC+N
Power consumption : 2 kW
Operating pressure : 6 Bar
Air consumption : 350 NL/min.

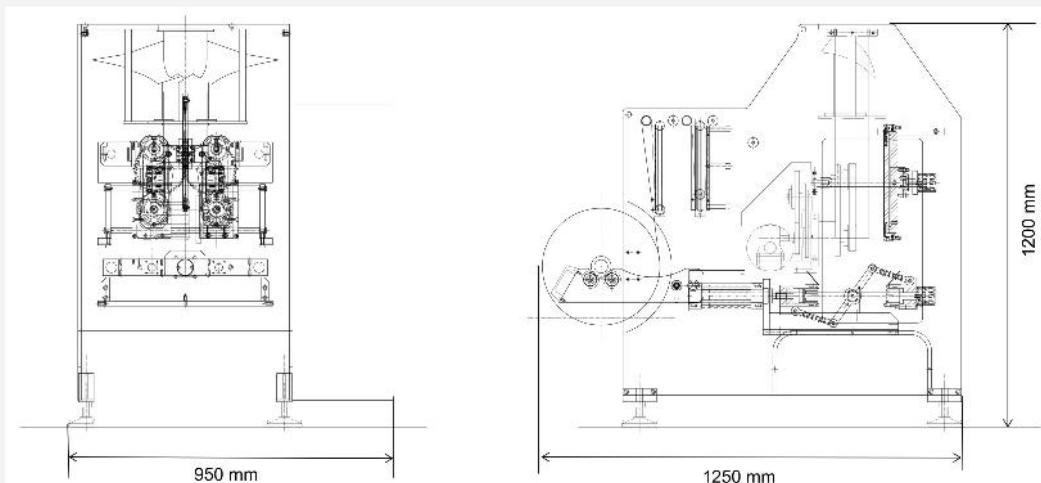

WPI Services B.V., Tel. +31 70 3067100, info@weighpack.nl

www.weighpack.nl