



weighpack

Packaging Solutions

Semi-auto Bulk Packaging Table type STW350





weighpack

Packaging Solutions

Semi-auto Bulk Packaging Table type STW350

General characteristics:

- Suitable to run short batches.
- Solid main frame made of welded and painted steel.
- Equipped with heavy duty vibration feed tray to fill bulk containers or bags.
- 1200 mm long feed "V" tray.
- Multiple vibration speeds to control dynamic bulk and fine weighing.
- Digital display for weight and piece read-out.
- Integrated weighing platform integrated in packing table to control product flow.
- Chute system to hold exchangeable filling chutes.
- Integrated check weighing scale.
- Packing in weight or count.
- Integrated control cabinet with main power and Siemens PLC controls.
- Contact part lined with sound- and wear reductive diamond coating.
- Pneumatic operated bulk flap.
- Special executions possible.
- CE certification.

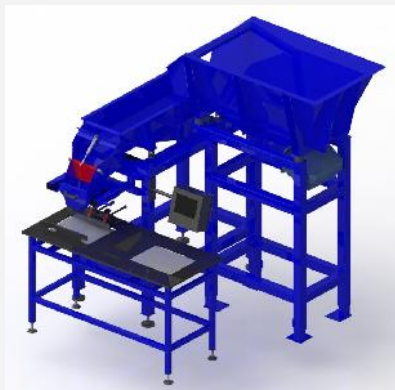

Technical characteristics:

Min. product length	: 5 mm	Speed	: Up to 4 packs/min.
Max. product length	: 150 mm	Feeding capacity	: Up to 4800 kg/hr.
Min. product diameter	: 5 mm	Weight	: 670 kg
Max. product diameter	: 30 mm	Power supply	: 3x400VAC+N
Max. product height	: 2 mm	Power consumption	: 2 kW
Max. product height	: 80 mm	Operating pressure	: 6 Bar
Weight range	: 2-25 kg	Air consumption	: 12 NL/min.

WPI Services B.V., Tel. +31 70 3067100, info@weighpack.nl

www.weighpack.nl