

FASCETTE STRINGITUBO A DUE FILI CON VITE

WIRE HOSE CLAMPS WITH SCREW

**MATERIALI:**

ACCIAIO PRE-ZINCATO ESENTE ESENTE CROMO VI
ZINCATURA BIANCA

MATERIALS:

STEEL TOHS COMPLIANT COATING

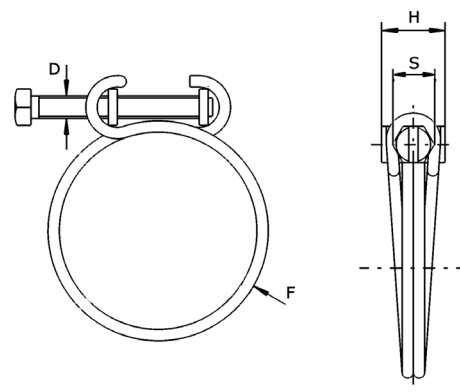

Riferimento Reference	Ø Max	Ø Min	Ø F filo wire	H mm	Ø D vite screw	S=esag. S=hex.
1512	12	11	1,5	11	M3	5,5
1513	13	11,5				
1514	14	12,5				
1515	15	13				
1816	16	14	1,8			
1817	17	15				
1818	18	16				
1819	19	17				
1820	20	18				
1821	21	18,5				
0222	22	20	2			
0223	23	20,5				
0225	25	22	2,2			
0227	27	23,5				
0229	29	25				
2231	31	27				
2233	33	29				
2235	35	31,5				
2237	37	33				
2240	40	37				
2243	43	38,5				

Riferimento Reference	Ø Max	Ø Min	Ø F filo wire	H mm	Ø D vite screw	S=esag. S=hex.			
2864	64	56,5	2,8	18	M6	10			
2868	68	60							
2872	72	64							
2876	76	68,5							
0380	80	72,5	3						
0384	84	76,5							
0388	88	80							
0392	92	84							
0396	96	88							
03100	100	92							
25104	104	95	2,5				15	M5	8
03108	108	98	3	18	M6	10			
03112	112	103							
03116	116	109							
3120	120	111							
3124	124	115							
3128	128	117							
3132	132	124							
38140	140	125	3,8				25	M8	13
38150	150	135							
38160	160	145							
38165	165	150							
38170	170	155							
38180	180	165							
38190	190	175							

