

PointSenz PCM 10-P

PointSenz PCM 10-P is optimised for the electronic measurement of bipolar DC currents, with galvanic separation between the primary and the secondary circuit.



$$I_{PN} = 10 A$$



Electrical data

I_{PN}	Primary nominal RMS current	10	A
I_{PM}	Primary current, measuring range	0 ... ± 20	A
\hat{I}_P	Overload capability	30000	At
I_{out}	Analogue output current @ $I = 0$	12	mA
I_{out}	Analogue output current @ $-I_P$	4	mA
I_{out}	Analogue output current @ $+I_P$	20	mA
R_M	Measuring resistance	50 ... 250	Ω
U_C	Supply voltage ¹⁾	(-30 %, +25 % continuous) (-40 %, +40 % intermittent)	+24 V
I_{Cmax}	Maximum current consumption ²⁾	50	mA

Accuracy - Dynamic performance data

		Typical	
X	Accuracy ^{3) 4)} (5 % of $-I_{P...} + I_P$), @ $T_A = +25^\circ C$, $U_C = +24 V$	± 1.0	% of I_P
	Position sensitivity relative to center reading (max)	± 1.5	% of I_P
ϵ_L	Linearity error ³⁾ (0 ... $\pm I_P$)	± 0.2	% of I_P
	External field rejection	200 : 1	
$I_{OE max}$	Maximum electrical offset current @ $I_P = 0$, $T_A = 25^\circ C$	$+12 \pm 0.3$	mA
$I_{OE typ}$	Typical electrical offset current @ $I_P = 0$, $T_A = 25^\circ C$	$+12 \pm 0.1$	mA
I_{OM}	Magnetic offset current @ $I_P = 0$ and specified R_M , after an overload of $3 \times I_{PN}$	± 0.02	mA
I_{OT}	Temperature variation of I_O , $T_A = -25^\circ C \dots +85^\circ C$	± 0.03	mA/ $^\circ K$
TCG	Temperature coefficient of G , $T_A = -25^\circ C \dots +85^\circ C$	± 0.05	%/ $^\circ K$
t_r	Step response time to 90 % of I_{PN} ⁵⁾	< 10	μs
BW	Frequency bandwidth (-3 dB)	DC ... 1	kHz

General data

T_A	Ambient operating temperature (continuous)	-40 ... +85	$^\circ C$
T_S	Ambient storage temperature	-40 ... +85	$^\circ C$
	Relative humidity $T_A = 40^\circ C$	95	%
m	Mass	130	g
Standards: Electrically driven points machine		BS 581	
	Vibration	BR 967: 1973 cat. D	
	EMC	EN 50121-5: 2001	
	EMC	EN 50121-3-2: 20015 ⁶⁾	
	Railway applications (power supply, temperature & humidity)	EN 50155: 1995	

This product is designed to conform with the relevant sections of GM/RC 1500, and is intended for use in applications and environments which comply with GS/ES 1914 and GM/R7 1031.

N° 60.05.13.100.0

Features

- Closed loop (compensated) current transducer using the Hall effect
- Panel mounting
- Split core design for easy installation
- Insulating plastic case recognized according to UL 94-V0
- Water resistant design rated to IP 67
- Reverse polarity protected.

Advantages

- Excellent accuracy
- Very good linearity
- No insertion losses
- Current overload capability
- Non-contact measurement (does not need a safety case).

Applications

- Points condition monitoring
- Signal light indication
- Battery supplied applications
- Uninterruptable Power Supplies (UPS).

Application Domain(s)

- Track side.

Notes:

¹⁾ Reverse polarity protection

²⁾ Including I_{out}

³⁾ Excludes electrical offset

⁴⁾ Includes linearity with the conductor in the center of the aperture

⁵⁾ For a $di/dt > 50 A/\mu s$

⁶⁾ Deviation of the offset during the test IEC 61000-4-3 @ 20V/m between 500 MHz and 1 GHz

Current Transducer PCM 10-P

Insulation coordination

U_b	Rated insulation RMS voltage, reinforced or basic insulation ¹⁾	50 Min	V
d_{cp}	Creepage distance	12	mm
d_{cl}	Clearance	10	mm
CTI	Comparative tracking index (group IIIa)	175	

Note: ¹⁾ Overvoltage category III, Pollution degree 2.

Safety



This transducer must be used in electric/electronic equipment with respect to applicable standards and safety requirements in accordance with the manufacturer's operating instructions.



Caution, risk of electrical shock

When operating the transducer, certain parts of the module can carry hazardous voltage (e.g. primary busbar, power supply).

Ignoring this warning can lead to injury and/or cause serious damage.

This transducer is a build-in device, whose conducting parts must be inaccessible after installation.

A protective housing or additional shield could be used.

Main supply must be able to be disconnected.

Dimensions PCM 10-P (in mm)

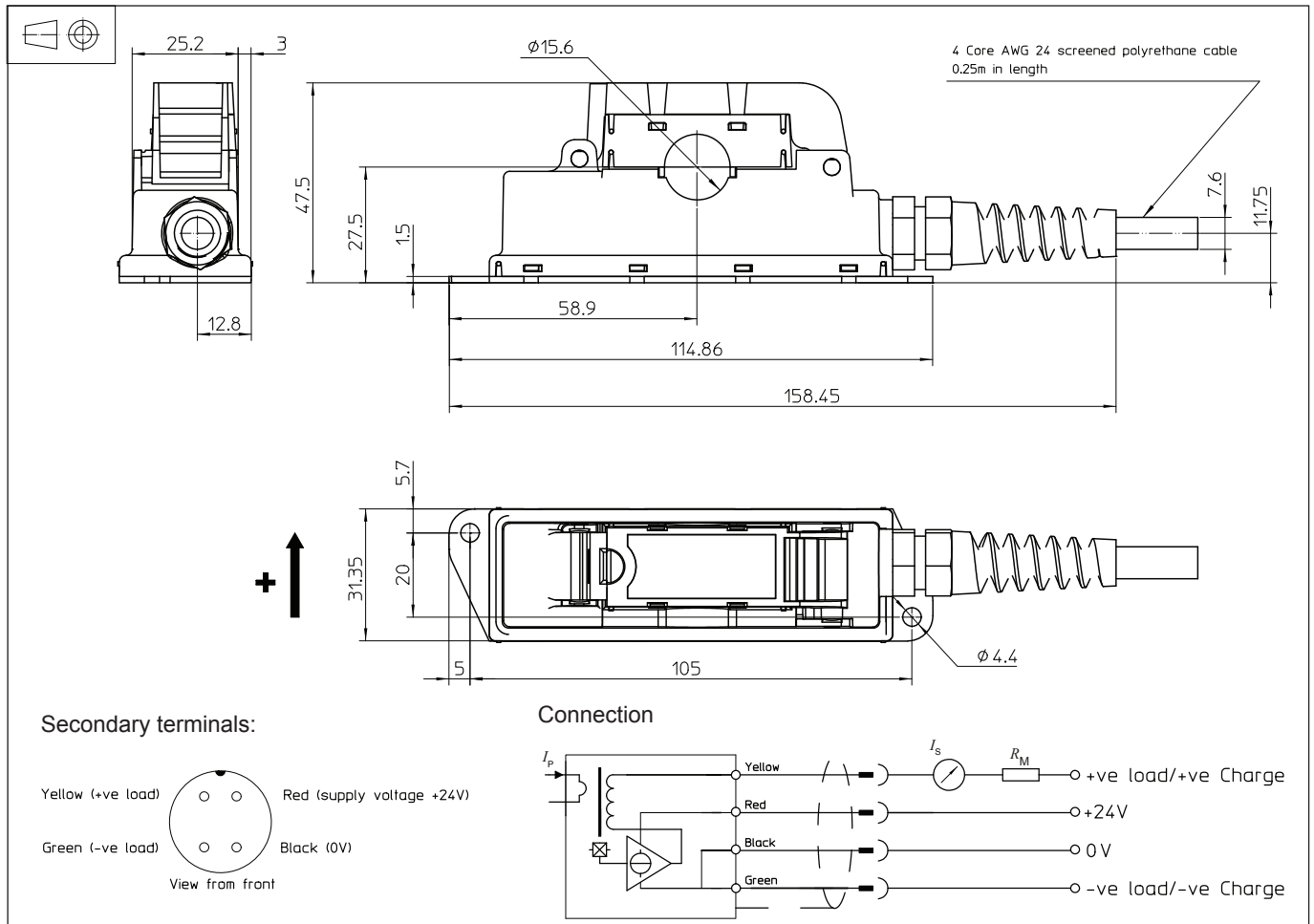

Mechanical characteristics

- General tolerance ± 0.5 mm
- Primary through-hole $\phi 15$ mm
- Connection of secondary Via 4 core screened polyurethane cable 0.25 m in length, Halogen free, terminated with Switchcraft EN3L4M connector
- Enclosure UL 94-V0 rated plastic

Remarks

- I_s is positive when I_p flows in the direction of the arrow.
- Temperature of the primary conductor should not exceed 90°C .
- This unit is intended for direct mounting in track side applications. It should only be installed or removed from isolated hazardous live conductors or uninsulated hazardous live conductors which are switched off.
- As it is a sealed unit no moisture should be allowed to ingress into the unit during installation.
- Connections between the transducer and the customers power supply and output monitoring equipment should be made with screened cable.
- Installation of the transducer must be done unless otherwise specified on the datasheet, according to LEM Transducer Generic Mounting Rules. Please refer to LEM document N°ANE120504 available on our Web site: [Products/Product Documentation](#).
- This is a standard model. For different versions (supply voltages, turns ratios, unidirectional measurements...), please contact us.