

PointSenz series of sensors are optimised for the electronic measurement of bipolar DC currents, with a galvanic isolation between the primary (high power) circuit and the secondary (electronic) circuit.

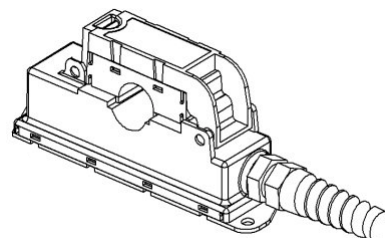

Electrical data

I_{PN}	Primary nominal DC	10	A
I_P	Primary current, measuring range	0 .. ± 20	A
\hat{I}_P	Overload capacity (Ampere Turns)	30000	A
I_{OUT}	Analogue output current @ $I = 0$	12	mA
I_{OUT}	Analogue output current @ $+I_P$	20	mA
I_{OUT}	Analogue output current @ $-I_P$	4	mA
R_M	Measuring resistance	50 .. 250	Ω
V_C	Supply voltage ¹⁾ (- 30 %, + 25 % continuous) (- 40 %, + 40 % Intermittent)	+24	V
I_C	Current consumption (max) ²⁾	50	mA
V_b	Rms rated voltage ³⁾	50	V

Accuracy - Dynamic performance data

X	Accuracy ^{4),5)} (5% $\pm I_P$.. $\pm I_P$) @ $T_A = +25^\circ C$, $V_C = +24 V$	± 1.0	% of I
	Position sensitivity relative to centre reading (max)	± 1.5	% of I
ϵ_L	Linearity ⁴⁾ (0 .. $\pm I_P$)	± 0.2	% of I_P
	External field rejection	200 : 1	
I_{OE}	Electrical offset current @ $I_P = 0$, $T_A = 25^\circ C$ (Typically)	+12 ± 0.3 +12 ± 0.1	mA mA
I_{OM}	Residual offset current @ $I_P = 0$ after an overload of $3 \times I_{PN}$	± 0.02	mA
I_{OT}	Thermal drift of offset current I_{OE} $T_A = -25 .. + 70^\circ C$	± 0.03	mA/°K
TCE_G	Thermal drift of gain $T_A = -25 .. + 70^\circ C$	± 0.05	%/°K
t_r	Response time @ 90 % of I_P	< 10	μs
di/dt	di/dt accurately followed	> 50	A/ μs
f	Frequency bandwidth (- 3 dB)	DC .. 1	kHz

General data

T_A	Ambient operating temperature (continuous) (intermittent)	- 25 .. + 55 - 25 .. + 70	°C °C
T_S	Ambient storage temperature	- 25 .. + 85	°C
	Relative humidity $T_A = 40^\circ C$	95	%
m	Mass	120	g
	Standards: Electrically driven points machines	BS 581	
	Vibration	BR 967:1973 cat. D	
	EMC	EN 50121-5	
	Railway applications (power supply, temperature & humidity)	EN 50155	
	Safety	EN 61010-1/2	
	(For installation information see over)		

This product is designed to conform with the relevant sections of GM/RC 1500, and is intended for use in applications and environments which comply with GS/ES 1914 and GM/R7 1031.

Features

- Closed loop sensor using Hall Effect
- Panel mounting
- Split core design for easy installation
- Insulated plastic case to UL 94-V0
- Reverse polarity protected.

Advantages

- Very good linearity
- Excellent accuracy
- Current overload capability
- No insertion losses.
- Non - contact measurement (does not need a safety case)

Applications

- Railway equipment
- Points condition monitoring
- Signal light indication
- Battery supplied applications
- Uninterruptable Power Supplies (UPS).

Notes : ¹⁾ Reverse polarity protection

²⁾ Including I_{OUT}

³⁾ Overvoltage category III,
Pollution degree 2

⁴⁾ Excludes electrical offset

⁵⁾ Includes linearity with the conductor in the centre of the aperture.

Dimensions PCM 10-P/SP1 (in mm. 1 mm = 0.0394 inch)

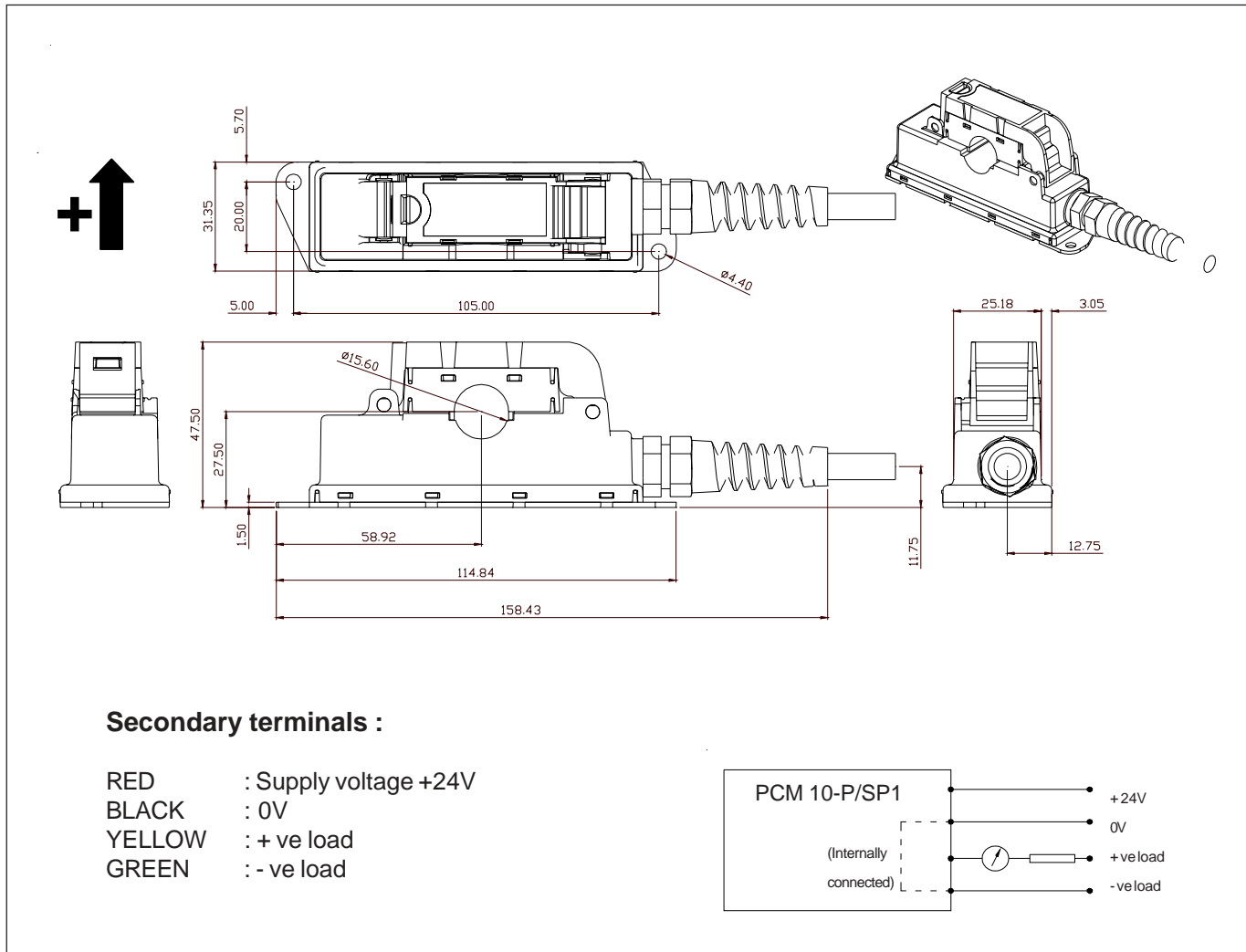

Mechanical characteristics

- General tolerance ± 0.5 mm
- Primary through-hole $\phi 15$ mm
- Connection of secondary Via 4 core screened polyurethane cable 2 m in length, Halogen free
- Enclosure UL 94-V0 rated plastic

Remarks

- I_{OUT} is positive when I_p flows in the direction of the arrow.
- Temperature of the primary conductor should not exceed 90°C.
- This unit is intended for direct mounting in trackside applications. It should only be installed or removed from insulated hazardous live conductors or uninsulated hazardous live conductors which are switched off.
- As it is a sealed unit no moisture should be allowed to ingress into the unit during installation.
- Connections between the transducer and the customers power supply and output monitoring equipment should be made with screened cable.
- This is a standard model. For different versions (supply voltages, secondary connections, unidirectional measurements, operating temperatures, etc.) please contact us.