

# Modbus TCP/IP Communication Digital Input/Output Addendum July 2009



## 1. Inputs

### 1.1 Description

Two independent digital inputs are provided which may be used as Digital Status or Accumulating Pulse Count inputs. The inputs are safety isolated at 2.5kV from the power metering circuits.

#### 1.1.1 Use As Pulse Accumulators

Each input may be derived from a volt free, normally open contact pair such as those found on modern utility meters. Four independent 32-Bit registers (max count 4,294,967,296) are provided which accumulate input pulses and store them in non-volatile memory. Each register may be read and/or written as registers in a Modbus data table.

#### 1.1.2 Use as Digital Inputs Via Modbus TCP/IP

Each input may be used as a Modbus discrete digital input. Standard Modbus commands may be used to read the digital status of each channel.

### 1.2 Inputs Connection

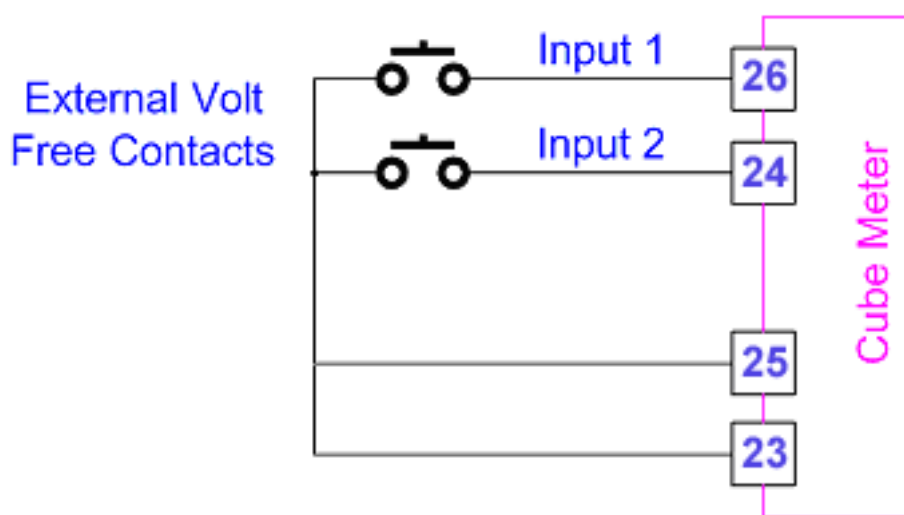

Figure 1-1 Input Connection

## 2. Outputs

### 2.1 Description

Two independent digital outputs are provided which may be used as control inputs or alarms to external switching devices. Each output takes the form of an isolated normally open volt free contact pair.

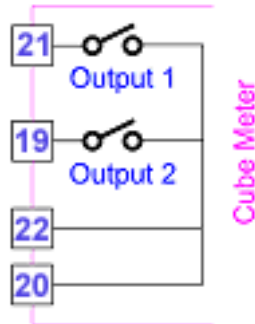

Figure 2-1 Output Schematic (Shown in auxiliary power off state)

#### 2.1.1 Use as Modbus Controlled Outputs

Each output may be configured individually as a control output with On/Off status set using normal Modbus commands.

**Note:** The outputs are of a NON-HOLDING type and will be released to the OFF state in the event of a loss of auxiliary power to the meter.

#### 2.1.2 Use as Alarm Outputs

Each output may be configured individually as an Alarm status output. In this mode a parameter is associated with the Alarm using its Modbus Data Address. Any instantaneous Modbus parameter may be chosen to control the alarm. Each Alarm features High and/or Low settings with hysteresis. A time delay may optionally be associated with the setting to delay a trip condition until valid for a set period of time.

## **3. Modbus Communications**

### **3.1 Table 26 External Pulse Input Count Registers**

Offset	Address	Modbus Address	Contents	Format	Bytes	Words	Access
0	6656	46657	Count 1 Hi	Unsigned Long	4	2	Read/Write
1	6657	46658	Count 1 Lo				
2	6658	46659	Count 2 Hi	Unsigned Long	4	2	Read/Write
3	6659	46660	Count 2 Lo				

#### **3.1.1.1 External Pulse Input Count Registers**

Pulse Input Count registers accumulate pulses from external sources via the Input/Output & Modbus option. These registers may be used to record pulses from other pulsing devices such as gas, water steam meters etc. The two resultant 4-byte registers are stored in Modbus Table 26 as unsigned long integers.

#### **3.1.1.2 Reading Input Count Registers**

Function 3 or 4 may be used to read the input count registers in Table 26. These Modbus commands are covered in full in “***Cube400 Modbus Comms Manual***”.

#### **3.1.1.3 Writing to Input Count Registers**

Function 6 or 16 may be used to write to the Input Count registers in Table 26. These Modbus commands are covered in full in “***Cube400 Modbus Comms Manual***”.

Function 6 allows access to the upper and lower integers of the 4-byte long individually. Function 16 may be used to access a number of long integers using a single command. This is most useful for setting all registers to 0 simultaneously.

## 3.2 Table 27 External Status Registers

Offset	Address	Modbus Address	Contents	Format	Bytes	Words	Access
0	6912	46913	Combined Contact Status	Integer	2	1	Read
1	6913	46914	Input 1 Status	Integer	2	1	Read
2	6914	46915	Input 2 Status	Integer	2	1	Read
3	6915	46916	Output 1 Status	Integer	2	1	Read
4	6916	46917	Output 2 Status	Integer	2	1	Read

### 3.2.1 Combined Contact Status Register

This 16-Bit register provides a single location to read the status of the 2 Digital Inputs and the 2 Coil outputs. The register is formatted as follows:

BIT	15	14	13	12	11	10	9	8	7	6	5	4	3	2	1	0
	0	0	0	0	0	0	OUT2	OUT1	0	0	0	0	0	0	IN2	IN1

### 3.2.2 External Pulse Input Status Registers

The Modbus protocol recommends that Status registers are read using Function 02. This function is supported by the Cube400 and is described below. The Cube400 provides an alternative method of reading Status contacts making use of Modbus commands 03 or 04.

**Table 27** stores a 16-bit register for each Status Input as:

Input Open Circuit	Input Status register = 0
Input Short Circuit	Input Status register = 65535 (-1)

### 3.2.3 External Pulse Coil Output Status Registers

The Modbus protocol recommends that Status registers are read using Function 02. This function is supported by the Cube400 and is described below. The Cube400 provides an alternative method of reading Input Status contacts making use of Modbus commands 03 or 04.

**Table 27** stores a 16-bit register for each Output Coil Status as:

Output Open Circuit	Output Coil Status register = 0
Output Short Circuit	Output Coil Status register = 65535 (-1)

## 3.3 Table 28 Digital Alarm Outputs

Offset	Address	Modbus Address	Contents	Format	Access
0	7168	47169	Alarm 1 Data Address	Unsigned Integer	Read/Write
1	7169	47170	Alarm 1 High Set Point	Signed Integer	Read/Write
2	7170	47171	Alarm 1 High Release Point	Signed Integer	Read/Write
3	7171	47172	Alarm 1 Low Release Point	Signed Integer	Read/Write
4	7172	47173	Alarm 1 Low Set Point	Signed Integer	Read/Write
5	7173	47174	Alarm 1 Set Delay (Seconds)	Signed Integer	Read/Write
6	7174	47175	Alarm 1 Status	Signed Integer	Read/Write
7	7175	47176	Alarm 1 Parameter Value	Signed Integer	Read Only
8	7176	47177	Alarm 2 Data Address	Unsigned Integer	Read/Write
9	7177	47178	Alarm 2 High Set Point	Signed Integer	Read/Write
10	7178	47179	Alarm 2 High Release Point	Signed Integer	Read/Write
11	7179	47180	Alarm 2 Low Release Point	Signed Integer	Read/Write
12	7180	47181	Alarm 2 Low Set Point	Signed Integer	Read/Write
13	7181	47182	Alarm 2 Set Delay (Seconds)	Signed Integer	Read/Write
14	7182	47183	Alarm 2 Status	Signed Integer	Read/Write
15	7183	47184	Alarm 2 Parameter Value	Signed Integer	Read Only

### 3.3.1 Using Outputs as Alarms

Each output may be individually setup to provide an over/under alarm function. Configuration is carried out using the Modbus interface as shown in **Table 28**.

#### 3.3.1.1 Enabling the Alarm Function

To switch between Modbus Control Output and Alarm functionality write to the “**Alarm n Data Address**” register in Table 28. Output 1 is set by writing to register 47169 and Output 2 at register 47177.

0 = Modbus Controlled Output  
>0 = Alarm Output

### 3.3.2 Alarm Operation

#### 3.3.2.1 Alarm Parameters

Each Alarm is associated with a single Modbus register, which in turn is linked to a measured parameter in the meter.

To associate a measured parameter with an alarm output write it’s **Data Address** to **Table 28**.

A complete list of Modbus register **Data Addresses** is given in the **Cube400 Modbus Communications Manual**.

**For example:** Writing 2821 to **Table 28** register 47169 will associate Alarm Output 1 with Phase 1 Voltage Input. The instantaneous phase voltage will then be copied to Modbus register 47176.

**Note:** The scaling of the input value is the same as that provided over the Modbus link. A phase voltage display of 240.0, for example would provide a Modbus register value of 2400.

The **Cube400** instantaneous parameters are updated once a second. Each new measurement value provides a true rms reading, which takes account of all

## Modbus Communications

short-term fluctuations and transient behaviour during that second. Alarm inputs reflect these values and therefore outputs react at the end of each second to the rms values and not to transients.

### 3.3.2.2 Set Points

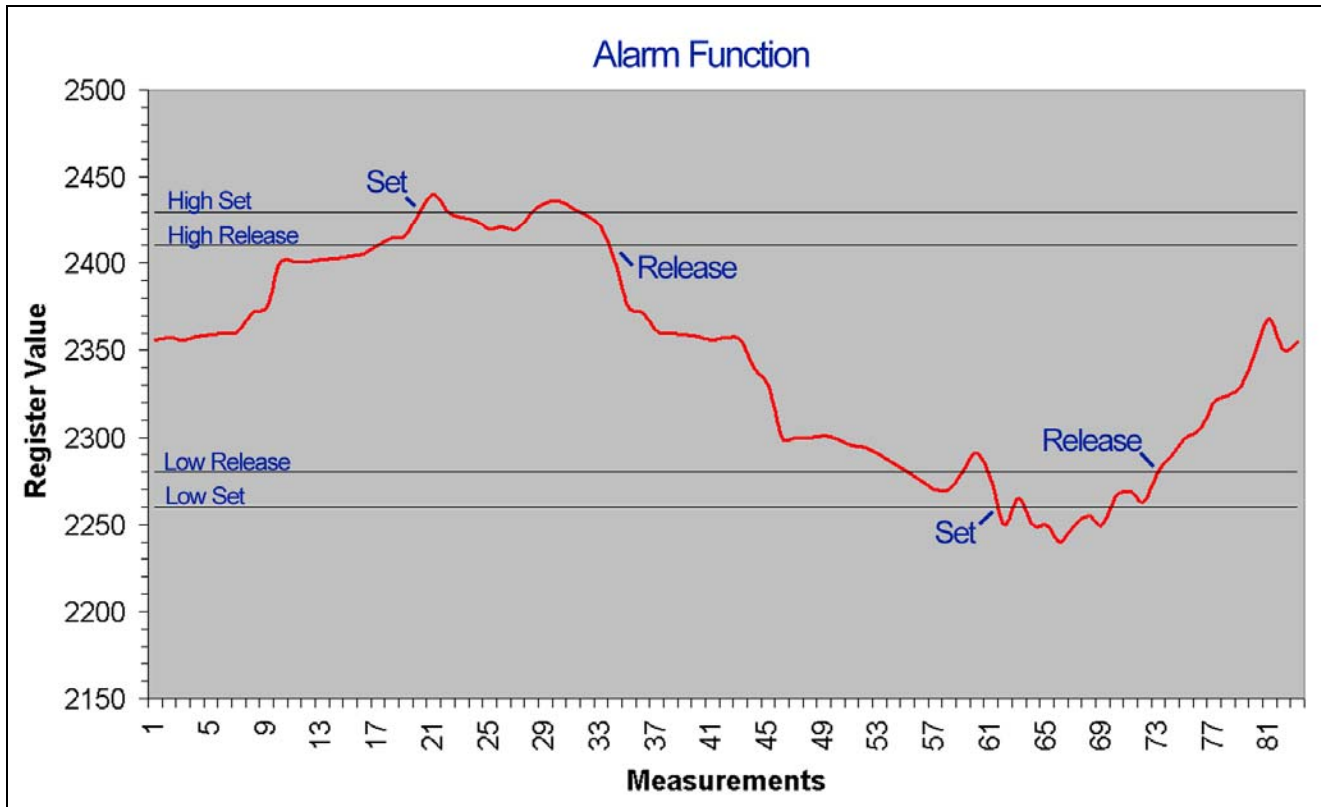

Figure 1 Alarm Set Points

**Set Delay** – The consecutive period of time a **High Set** or **Low Set** point must be exceeded before an alarm output is set. Alarms are released on detecting a release condition with no delay.

**High Set Point** – If the value in the selected Modbus register exceeds this value for a time period greater than the **Set Delay** the alarm is set (**Set High**).

**High Release Point** – If the alarm is **Set High** and the value in the selected Modbus register is lower than this value, for a single measurement period (1 second) the alarm is released.

**Low Set Point** – If the value in the selected Modbus register is lower than this value for a time period greater than the **Set Delay** the alarm is set (**Set Low**).

**Low Release Point** – If the alarm is **Set Low** and the value in the selected Modbus register exceeds this value, for a single measurement period (1 second) the alarm is released.

Alarm Status – Each Alarm status is available at a Modbus register as:

**0 = Alarm Released**

**1 = Alarm Set High**

**2 = Alarm Set Low**

The status of each Alarm may be written using Modbus command 03 and 04. This allows a great deal of flexibility with the Cube400 Alarm functions.

### Example 1 – Over-Alarm

**Alarm if Phase 1 Amps > 150A. (CT Primary = 200A).**

Data Address	Modbus Address	Description	Value
7168	47169	Alarm 1 Data Address	2822
7169	47170	Alarm 1 High Set Point	1500
7170	47171	Alarm 1 High Release Point	1400
7171	47172	Alarm 1 Low Release Point	0
7172	47173	Alarm 1 Low Set Point	0
7173	47174	Alarm 1 Set Delay (Seconds)	0

**Note:** The Low Set/Release points are set to zero. Phase 1 Amps can never exceed these values so they become inactive.

### Example 2 – Under-Alarm

**Alarm if Phase 3 Volts < 220V. (PT Primary = 400V<sub>L-L</sub>).**

Data Address	Modbus Address	Description	Value
7168	47169	Alarm 1 Data Address	2827
7169	47170	Alarm 1 High Set Point	10000
7170	47171	Alarm 1 High Release Point	10000
7171	47172	Alarm 1 Low Release Point	2250
7172	47173	Alarm 1 Low Set Point	2200
7173	47174	Alarm 1 Set Delay (Seconds)	0

**Note:** The High Set/Release points are set to 10000 (1000.0V). Phase Volts can never exceed these values so they become inactive.

## Modbus Communications

---

### Example 3 – Over/Under-Alarm

Alarm if Phase 3 Volts < 211.6V. (PT Primary = 400V<sub>L-L</sub>).

Alarm if Phase 3 Volts > 248.4V

Data Address	Modbus Address	Description	Value
7168	47169	Alarm 1 Data Address	2827
7169	47170	Alarm 1 High Set Point	2484
7170	47171	Alarm 1 High Release Point	2450
7171	47172	Alarm 1 Low Release Point	2150
7172	47173	Alarm 1 Low Set Point	2116
7173	47174	Alarm 1 Set Delay (Seconds)	0

**Note:** This setting detects if phase voltage is out of the normal 230V  $\pm$ 8% band.

### Example 4 – Latching Over Alarm

Alarm if Phase 1 Amps > 180A. (CT Primary = 200A).

Data Address	Modbus Address	Description	Value
7168	47169	Alarm 1 Data Address	2822
7169	47170	Alarm 1 High Set Point	1800
7170	47171	Alarm 1 High Release Point	0
7171	47172	Alarm 1 Low Release Point	0
7172	47173	Alarm 1 Low Set Point	0
7173	47174	Alarm 1 Set Delay (Seconds)	5
7174	47175	Alarm 1 Status	0 to RESET

**Note:** This Alarm will Set if the current exceeds 180.0A for a consecutive period of 5 seconds or more. The High Release point is set to zero so an Alarm will remain set until reset by the user. Reset is performed by writing a zero to Modbus address 47175.

## 3.4 Additional RTU Commands

### 3.4.1 Modbus Coils

The Modbus protocol was written with programmable controllers in mind and much of the terms used are derived from this market. The term **Coil** is used widely in Modbus when referring to single bit control outputs. In the Cube400 Option Module we will use the term “**Digital Output**” in place of the term **Coil**.

### 3.4.2 Modbus Inputs

The term **Input** is used in Modbus when referring to single bit control inputs. In the Cube400 Option Module we will use the term “**Digital Input**” in place of the term **Input**.



### 3.4.3 Function 01      Read Digital Output Status

#### Description

This function reads the ON/OFF status of the Digital Outputs. This command is not available as a *broadcast* command as it requires a return data packet from the meter.

#### Host Request

	BYTE	EXAMPLE
METER ADDRESS	1	19H
FUNCTION	2	01H
First Digital Output Address Hi	3	00H
First Digital Output Address Lo	4	00H
No. of Points (High Byte)	5	00H
No. of Points (Low Byte)	6	03H
CHECKSUM (High Byte)	7	7FH
CHECKSUM (Low Byte)	8	D3H

The Cube400 has only 2 digital outputs addresses 00H and 01H.

Byte 3 of the Host Request should always be 00H.

Byte 4 of the host request must be equal to 00H or 01H depending on the first output required.

Byte 5 must always be zero.

Byte 6, the number of points requested, must be less than or equal to 2.

#### Meter Response

	BYTE	EXAMPLE
METER ADDRESS	1	19H
FUNCTION	2	01H
NUMBER OF BYTES	3	01H
Digital Output Bits	4	00000111
CHECKSUM (High Byte)	5	16H
CHECKSUM (Low Byte)	6	EAH

The number of bytes will always be 01H for the Cube400 as the unit contains only 2 digital outputs (2-Bits)

#### Digital Output Bits

The least significant bit (bit 0) of the **Digital Output Bits** data byte contains the status of the first **Digital Output** requested.

Bit 1 contains the status of the next bit (if requested).

1=ON / CLOSED  
0=OFF / OPEN.

The most significant bits not used to represent Digital Output status are set to zero.

# Modbus Communications

---

## Example 1

### Request

First Digital Output Address      00H, 00H  
Number of Points                    00H, 02H

### Reply

0	0	0	0	0	0	S2	S1
---	---	---	---	---	---	----	----

*Digital Output Bits*

## Example 2

### Request

First Digital Output Address      00H, 00H  
Number of Points                    00H, 01H

### Reply

0	0	0	0	0	0	0	S1
---	---	---	---	---	---	---	----

Digital Output Bits

## Example 3

### Request

First Digital Output Address      00H, 01H  
Number of Points                    00H, 01H

### Reply

0	0	0	0	0	0	0	S2
---	---	---	---	---	---	---	----

Digital Output Bits

Where **Sn** represents the status of Digital Output n.  
1=ON/CLOSED, 0=OFF/OPEN

## 3.4.4 Function 02 Read Digital Input Status

### Description

This function reads the ON/OFF status of the Digital Inputs. This command is not available as a *broadcast* command as it requires a return data packet from the meter.

### Host Request

	BYTE	EXAMPLE
METER ADDRESS	1	19H
FUNCTION	2	02H
First Digital Input Address Hi	3	00H
First Digital Input Address Lo	4	00H
No. of Points (High Byte)	5	00H
No. of Points (Low Byte)	6	04H
CHECKSUM (High Byte)	7	7AH
CHECKSUM (Low Byte)	8	11H

The Cube400 has 2 digital inputs addresses 00H and 01H.

Byte 3 of the Host Request should always be 00H.

Byte 4 of the host request must be equal to 00H or 01H depending on the first digital input required in the reply.

Byte 5 must always be zero.

Byte 6 is the number of points requested and must be less than or equal to 2.

### Meter Response

	BYTE	EXAMPLE
METER ADDRESS	1	19H
FUNCTION	2	02H
NUMBER OF BYTES	3	01H
Digital Input Bits	4	00001111
CHECKSUM (High Byte)	5	E7H
CHECKSUM (Low Byte)	6	2CH

The number of bytes will always be 01H for the Cube400 as the unit contains only 2 digital inputs (2-Bits)

### Digital Input Bits

The least significant bit (bit 0) of the **Digital Input Bits** data byte contains the status of the first Digital Input requested.

If requested, bit 1 represent the status of the next **Digital Input**.

1=ON / CLOSED

0=OFF / OPEN.

The most significant bits not used to represent Digital Input status are set to zero.

# Modbus Communications

---

## Example 1

### Request

First Digital Input Address      00H, 00H  
Number of Points                    00H, 02H

### Reply

0	0	0	0	0	0	S2	S1
---	---	---	---	---	---	----	----

*Digital Input Bits*

## Example 2

### Request

First Digital Input Address      00H, 00H  
Number of Points                    00H, 01H

### Reply

0	0	0	0	0	0	0	S1
---	---	---	---	---	---	---	----

*Digital Input Bits*

## Example 3

### Request

First Digital Input Address      00H, 01H  
Number of Points                    00H, 01H

### Reply

0	0	0	0	0	0	0	S2
---	---	---	---	---	---	---	----

*Digital Input Bits*

Where **Sn** represents the status of Digital Input n.  
1=ON/CLOSED, 0=OFF/OPEN

## 3.4.5 Function 05 Force Single Digital Output

### Description

This function forces a single Digital Output to the ON or OFF status. This command is not available as a broadcast command.

### Host Request

	BYTE	EXAMPLE
METER ADDRESS	1	19H
FUNCTION	2	05H
Digital Output Address Hi	3	00H
Digital Output Address Lo	4	00H
Force Data Hi	5	FFH
Force Data Lo	6	00H
CHECKSUM (High Byte)	7	8FH
CHECKSUM (Low Byte)	8	E2H

The Cube400 has 2 Digital Outputs at addresses 00H and 01H. Byte 3 of the Host Request should always be 00H.

### Force Data Hi:Lo

To Force a Digital Output to ON  
 To Force a Digital Output to OFF

Hi:Lo = FF:00  
 Hi:Lo = 00:00

All other values of Hi:Lo will leave the status of the Digital Output unaffected.

### Meter Response

	BYTE	EXAMPLE
METER ADDRESS	1	19H
FUNCTION	2	05H
Digital Output Address Hi	3	00H
Digital Output Address Lo	4	00H
Force Data Hi	5	FFH
Force Data Lo	6	00H
CHECKSUM (High Byte)	7	8FH
CHECKSUM (Low Byte)	8	E2H

The normal response is an echo of the host request, returned after the Digital Output state has been forced.

# Modbus Communications

---

## 3.4.6 Function 15 Force Multiple Digital Outputs

### Description

This function forces each Digital Output in a sequence to the ON or OFF state. This command is not available as a broadcast command.

### Host Request

	BYTE	EXAMPLE
METER ADDRESS	1	19H
FUNCTION	2	0FH
Digital Output Address Hi	3	00H
Digital Output Address Lo	4	00H
Number of Points Hi	5	00H
Number of Points Lo	6	03H
Byte Count	7	01H
Force Data Bits	8	00H
CHECKSUM (High Byte)	9	8FH
CHECKSUM (Low Byte)	10	FDH

The Cube400 has 2 **Digital Outputs** at addresses 00H and 01H.

Byte 3 of the Host Request should always be 00H.

Byte 4 of the host request must be equal to 00H or 01H depending on the address of the first output to be forced.

Byte 5 must always be zero.

Byte 6 contains the number of points requested and must be less than or equal to 2.

Byte 7 the Byte Count field is always set to 01H for the Cube400, as only 1 byte of data is required to set the 2 Digital Output bits.

To force a Digital Output to ON (CLOSED) set the corresponding bit to 1.

To force a Digital Output to OFF (OPEN) set the corresponding bit to 0.

### Meter Response

	BYTE	EXAMPLE
METER ADDRESS	1	19H
FUNCTION	2	0FH
Digital Output Address Hi	3	00H
Digital Output Address Lo	4	00H
Number of Digital Outputs Hi	5	00H
Number of Digital Outputs Lo	6	03H
CHECKSUM (High Byte)	7	52H
CHECKSUM (Low Byte)	8	0EH

The normal response is returned after the Digital Output states have been forced.

**Example 1**

Set Digital Outputs as:

Digital Output 1 (Addr=00H) = ON  
Digital Output 2 (Addr=01H) = ON**Request**Digital Output Address                    00H, 00H  
Number of Points                         00H, 02H  
Byte Count                                 01H**Force Data Bits**

0	0	0	0	0	0	1	1
---	---	---	---	---	---	---	---

**Force Data = 03H****Note:** Unused bits in the Force Data byte must be set to 0.**Example 2**

Set Digital Outputs as:

Digital Output 1 (Addr=00H) = ON

**Request**Digital Output Address                    00H, 00H  
Number of Points                         00H, 01H  
Byte Count                                 01H**Force Data**

0	0	0	0	0	0	0	1
---	---	---	---	---	---	---	---

**Force Data = 01H****Note:** Unused bits in the Force Data byte must be set to 0.**Example 3**

Set Digital Outputs as:

Digital Output 2 (Addr=01H) = ON



**Request**Digital Output Address                    00H, 01H  
Number of Points                         00H, 01H  
Byte Count                                 01H**Force Data**

0	0	0	0	0	0	0	1
---	---	---	---	---	---	---	---

**Force Data = 03H****Note:** Unused bits in the Force Data byte must be set to 0.

### 4. Setting the Alarms Via the LCD

It is possible, via Modbus, to add Alarm setting functionality to the **Cube400** LCD, by writing value 7438 to Modbus registers 7169 and 7177. Programming menu. When enabled this feature allows easy access to alarm setting without further need of an RS485 Modbus link.

- Using the Modbus link, associate an alarm with a parameter (Ref 3.3.2.1) from **Modbus Table29** below.
- To enter programming mode Hold  and  together for 5 Seconds.  
**Note:** This function may be disabled for security purposes on some meters
- Press  to bypass programming of other meter settings as described in **Cube400 Operating Manual**.
- Change Alarm settings as described below.

#### 4.1 Modbus Table 29 Alarm Parameters For LCD Programming

Data Address	Modbus Register	Data	Scaling
7424	47425	System KW	Kp
7425	47426	System kVA	
7426	47427	System kvar	
7427	47428	kW Demand	
7428	47429	kVA Demand	
7429	47430	kvar Demand	
7430	47431	Phase 1 kW	
7431	47432	Phase 2 kW	
7432	47433	Phase 3 kW	
7433	47434	Phase 1 Amps	Ki
7434	47435	Phase 2 Amps	
7435	47436	Phase 3 Amps	
7436	47437	Average Amps	
7437	47438	Neutral Current	
7438	47439	Phase 1 Volts	Kv
7439	47440	Phase 2 Volts	
7440	47441	Phase 3 Volts	
7441	47442	Average Volts	
7442	47443	Line 1-2 Volts	
7443	47444	Line 2-3 Volts	
7444	47445	Line 3-1 Volts	
7445	47446	Frequency	500 = 50.0Hz
7446	47447	Phase 1 Power Factor	1000 = 1.000
7447	47448	Phase 2 Power Factor	
7448	47449	Phase 3 Power Factor	
7449	47450	System Power Factor	
7450	47451	Phase 1 Amps % THD	1000 = 100.0%
7451	47452	Phase 2 Amps % THD	
7452	47453	Phase 3 Amps % THD	
7453	47454	Phase 1 Volts % THD	
7454	47455	Phase 2 Volts % THD	
7455	47456	Phase 3 Volts % THD	



## 4.2 Selecting The Alarm Parameter

Once an Alarm is associated with any parameter from Table 29 it will become possible to change its settings in the LCD programming menu.

It is possible, in future, to re-associate the alarm with a different parameter from Table 29 using the programming menu:

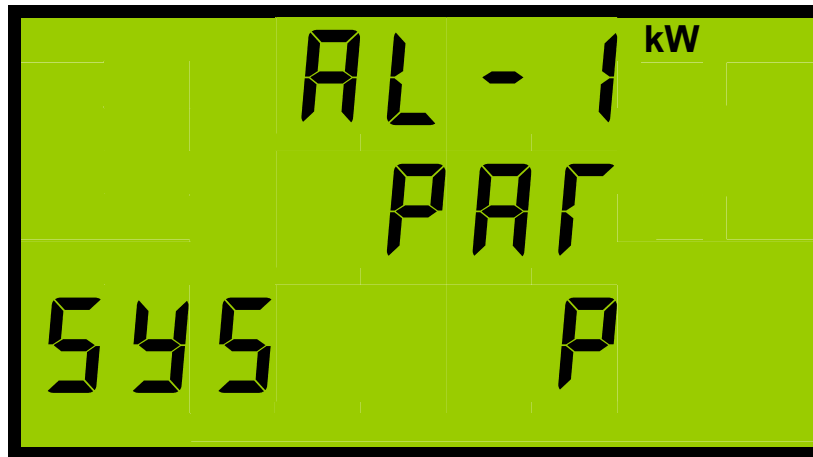

Figure 5.1 Alarm Parameter Setting

Press  or  to step Up/Down through the list of parameters.

<i>Parameter</i>	<i>Display</i>	<i>Legend</i>
	AL - 1	
	PAR	
System KW	545 P	kW
System kVA	545 S	kVA
System kvar	545 Q	kVAr
kW Demand	545 P d	T-Avg kW
kVA Demand	545 S d	T-Avg kVA
kvar Demand	545 Q d	T-Avg kVAr
Phase 1 kW	Ph 1 P	kW
Phase 2 kW	Ph 2 P	kW
Phase 3 kW	Ph 3 P	kW
Phase 1 Amps	Ph 1 A	A
Phase 2 Amps	Ph 2 A	A
Phase 3 Amps	Ph 3 A	A
Average Amps	545 A	A
Neutral Current	545 A n	bal A
Phase 1 Volts	Ph 1 U	V
Phase 2 Volts	Ph 2 U	V
Phase 3 Volts	Ph 3 U	V
Average Volts	545 U	V
Line 1-2 Volts	L 1 2 U	V
Line 2-3 Volts	L 2 3 U	V

## Setting Alarms Using the LCD

Line 3-1 Volts	L 3 1	U	V
Frequency		F F E 9	Hz
Phase 1 Power Factor	P h 1	P F	COSØ
Phase 2 Power Factor	P h 2	P F	COSØ
Phase 3 Power Factor	P h 3	P F	COSØ
System Power Factor	S Y S	P F	COSØ
Phase 1 Amps % THD	P h 1	A t h d	A%
Phase 2 Amps % THD	P h 2	A t h d	A%
Phase 3 Amps % THD	P h 3	A t h d	A%
Phase 1 Volts % THD	P h 1	U t h d	V%
Phase 2 Volts % THD	P h 2	U t h d	V%
Phase 3 Volts % THD	P h 3	U t h d	V%

When the required parameter is associated with the alarm output press .

### 4.3 Changing The Alarm Set-Points

Each Alarm Set-Point may be changed, in-turn, within limits determined by the selected parameter as follows:

<b><i>Parameter</i></b>	<b><i>Maximum</i></b>	<b><i>Minimum</i></b>
System KW	$1.2x(Un \times CT)x\sqrt{3}$	$-1.2x(Un \times CT)x\sqrt{3}$
System kVA		
System kvar		
kW Demand		
kVA Demand		
kvar Demand		
Phase 1 kW	$1.2x(Un \times CT)/\sqrt{3}$	$-1.2x(Un \times CT)/\sqrt{3}$
Phase 2 kW		
Phase 3 kW		
Phase 1 Amps	CT x 1.2	0
Phase 2 Amps		
Phase 3 Amps		
Average Amps		
Neutral Current		
Phase 1 Volts	$1.2x(Un/\sqrt{3})$	0
Phase 2 Volts		
Phase 3 Volts		
Average Volts		
Line 1-2 Volts	1.2 x Un	0
Line 2-3 Volts		
Line 3-1 Volts		
Frequency	65.0Hz	45.0Hz
Phase 1 Power Factor	1.000	0
Phase 2 Power Factor		
Phase 3 Power Factor		
System Power Factor		
Phase 1 Amps % THD	100.0%	0.0%
Phase 2 Amps % THD		
Phase 3 Amps % THD		
Phase 1 Volts % THD		
Phase 2 Volts % THD		
Phase 3 Volts % THD		

## Setting Alarms Using the LCD

---

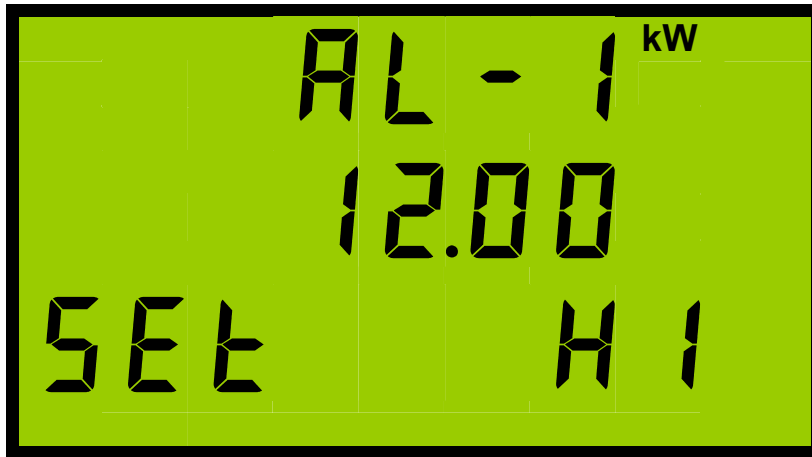





Figure 5.2 Alarm High Set Point

Press  or  to increase/decrease the set point. Hold down the key to increase the speed of change of the number.

Press  to select the next set point.

**Note:** Alarm set points will be limited dependant on the parameter as shown in the Table above. If a previous set point is outside these limits the default value will be set on entering the set-point page.

**Note:** Alarm set points are set in the order **SET-HIGH, RELEASE-HIGH, RELEASE LOW then SET LOW**. LCD programming prevents incorrect setting by ensuring each point cannot be set higher than the previous one.

### 4.4 Setting An Alarm Delay

An alarm delay may be set (Ref 3.3.2.2) preventing spurious triggering. This may be set using the LCD programming menu from 0-99 Seconds

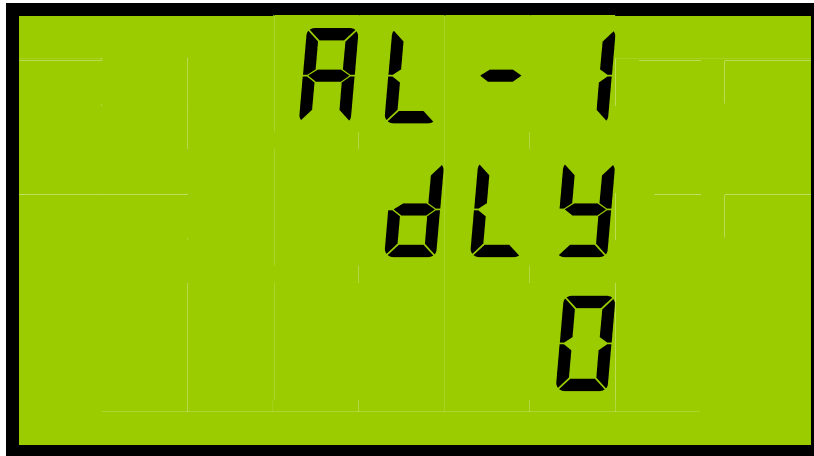

Figure 5.3 Alarm Delay Setting in Seconds

Press **P** **▲** or **E** **▼** to increase/decrease the delay point. Hold down the key to increase the speed of change of the number.

Press **I** **◀** to accept the required setting.

## 5. Specification

These specifications are provided as an addendum to those in the “**Cube400** ,  
**Modbus Comms Manual**.”

<b>Digital Inputs</b>	
<b>External Contacts</b> <b>Type</b> <b>Resistance</b> <b>Contact Rating</b>	Normally Open Volt Free Contacts Maximum 100 Ohms (Cable + contacts) 10mA; 24V DC
<b>Isolation</b>	2.5kV (1 min) to meter measurement circuits 50V to Digital Outputs Not Isolated from RS485 communications (Common 0V).
<b>Pulse ON Time</b> <b>Pulse OFF Time</b> <b>Pulse Rate</b>	55ms Minimum 25ms Minimum 10hz Maximum

<b>Digital Outputs</b>	
<b>Type</b> <b>Contacts</b>	Non-Holding, Volt free N/O contacts. Optically isolated BiFETs 100mA AC/DC max. 100V AC/DC max
<b>Isolation</b>	2.5kV (1 min) to meter measurement circuits 50V to Digital Inputs 50V to RS485 communications.