

# PROGRAMMABLE CONTROLLER

# PCB1

# INSTRUCTION MANUAL

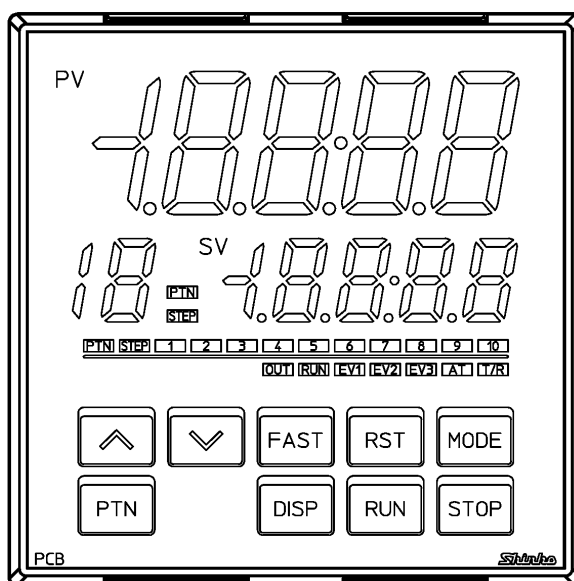

**Shinko**

# Preface

Thank you for purchasing our programmable controller PCB1. This manual contains instructions for the mounting, functions, operations and notes when operating the PCB1. To prevent accidents arising from the misuse of this controller, please ensure the operator receives this manual.

## Abbreviations used in this manual

Abbreviation	Term
PV	Process variable
SV	Desired value
MV	Output manipulated variable
OUT1	Control output OUT1
OUT2	Control output OUT2
AT	Auto-tuning

## Characters used in this manual (□: No character is indicated)

Indication	-1	0	1	2	3	4	5	6	7	8	9	℃	℉
Number, ℃/℉	-1	0	1	2	3	4	5	6	7	8	9	℃	℉
Indication	A	b	c	d	E	F	G	H	I	J	k	L	ñ
Alphabet	A	B	C	D	E	F	G	H	I	J	K	L	M
Indication	n	o	P	q	r	S	T	U	V	W	X	Y	Z
Alphabet	N	O	P	Q	R	S	T	U	V	W	X	Y	Z

# Notes

- This instrument should be used in accordance with the specifications described in the manual. If it is not used according to the specifications, it may malfunction or cause a fire.
- Be sure to follow the warnings, cautions and notices. If they are not observed, serious injury or malfunction may occur.
- The contents of this instruction manual are subject to change without notice.
- Care has been taken to ensure that the contents of this instruction manual are correct, but if there are any doubts, mistakes or questions, please inform our sales department.
- This instrument is designed to be installed through the control panel. If it is not, measures must be taken to ensure that the operator cannot touch power terminals or other high voltage sections.
- Any unauthorized transfer or copying of this document, in part or in whole, is prohibited.
- Shinko Technos Co., Ltd. is not liable for any damage or secondary damage(s) incurred as a result of using this product, including any indirect damage.

# Safety Precautions (Be sure to read these precautions before using our products.)

The safety precautions are classified into categories: "Warning" and "Caution". Depending on circumstances, procedures indicated by ⚠ Caution may result in serious consequences, so be sure to follow the directions for usage.

**⚠ Warning** Procedures which may lead to dangerous conditions and cause death or serious injury, if not carried out properly.

**⚠ Caution** Procedures which may lead to dangerous conditions and cause superficial to medium injury or physical damage or may degrade or damage the product, if not carried out properly.

## ⚠ Warning

- To prevent an electrical shock or fire, only Shinko or other qualified service personnel may handle the inner assembly.
- To prevent an electrical shock, fire or damage to the instrument, parts replacement may only be undertaken by Shinko or other qualified service personnel.

## ⚠ Safety Precautions

- To ensure safe and correct use, thoroughly read and understand this manual before using this instrument.
- This instrument is intended to be used for industrial machinery, machine tools and measuring equipment. Verify correct usage after purpose-of-use consultation with our agency or main office. (Never use this instrument for medical purposes with which human lives are involved.)
- External protection devices such as protective equipment against excessive temperature rise, etc. must be installed, as malfunction of this product could result in serious damage to the system or injury to personnel. Proper periodic maintenance is also required.
- This instrument must be used under the conditions and environment described in this manual. Shinko Technos Co., Ltd. does not accept liability for any injury, loss of life or damage occurring due to the instrument being used under conditions not otherwise stated in this manual.

### Caution with respect to Export Trade Control Ordinance

To avoid this instrument from being used as a component in, or as being utilized in the manufacture of weapons of mass destruction (i.e. military applications, military equipment, etc.), please investigate the end users and the final use of this instrument. In the case of resale, ensure that this instrument is not illegally exported.

## 1. Installation Precautions

### ⚠ Caution

**This instrument is intended to be used under the following environmental conditions (IEC61010-1): Overvoltage category II, Pollution degree 2**

**Ensure the mounting location corresponds to the following conditions:**

- A minimum of dust, and an absence of corrosive gases
- No flammable, explosive gases
- No mechanical vibrations or shocks
- No exposure to direct sunlight, an ambient temperature of -10 to 55°C (14 to 131°F) that does not change rapidly, and no icing
- An ambient non-condensing humidity of 35 to 85%RH
- No large capacity electromagnetic switches or cables through which large current is flowing
- No water, oil or chemicals or where the vapors of these substances can come into direct contact with the unit
- Please note that the ambient temperature of this unit – not the ambient temperature of the control panel – must not exceed 55°C (131°F) if mounted through the face of a control panel, otherwise the life of the electronic components (especially electrolytic capacitors) may be shortened.

**Note: Avoid setting this instrument directly on or near flammable material even though the case of this instrument is made of flame-resistant resin.**

## 2. Wiring Precautions



### Caution

- Do not leave wire remnants in the instrument, as they could cause a fire or malfunction.
- Use the solderless terminal with an insulation sleeve in which the M3 screw fits when wiring the instrument.
- The terminal block of this instrument is designed to be wired from the left side. The lead wire must be inserted from the left side of the terminal, and fastened with the terminal screw.
- Tighten the terminal screw using the specified torque. If excessive force is applied to the screw when tightening, the terminal screw or case may be damaged.
- Do not pull or bend the lead wire on the terminal side when wiring or after wiring, as it could cause malfunction.
- This instrument does not have a built-in power switch, circuit breaker and fuse. It is necessary to install a power switch, circuit breaker and fuse near the controller.  
(Recommended fuse: Time-lag fuse, rated voltage 250 V AC, rated current 2 A)
- For a 24 V AC/DC power source, do not confuse polarity when using direct current (DC).
- Do not apply a commercial power source to the sensor which is connected to the input terminal nor allow the power source to come into contact with the sensor.
- Use a thermocouple and compensating lead wire according to the sensor input specifications of this controller.
- Use the 3-wire RTD according to the sensor input specifications of this controller.
- For DC voltage input, (+) side input terminal number of 0 to 5 V DC, 1 to 5 V DC, 0 to 10 V DC differs from that of 0 to 1 V DC.

Terminal Number	DC Voltage Input
②①	(+) side of 0 to 5 V DC, 1 to 5 V DC, 0 to 10 V DC
②②	(+) side of 0 to 1 V DC

- When using a relay contact output type, externally use a relay according to the capacity of the load to protect the built-in relay contact.
- When wiring, keep input wires (thermocouple, RTD, etc.) away from AC power sources or load wires.

## 3. Operation and Maintenance Precautions



### Caution

- It is recommended that AT be performed on the trial run.
- Do not touch live terminals. This may cause electrical shock or problems in operation.
- Turn the power supply to the instrument OFF before retightening the terminal or cleaning.  
Working on or touching the terminal with the power switched ON may result in severe injury or death due to electrical shock.
- Use a soft, dry cloth when cleaning the instrument.  
(Alcohol based substances may tarnish or deface the unit.)
- As the display section is vulnerable, be careful not to put pressure on, scratch or strike it with a hard object.

# Contents

1. Model.....	7
1.1 Model .....	7
1.2 How to Read the Model Label .....	8
2. Name and Functions of Controller .....	9
3. Mounting to the Control Panel.....	12
3.1 External Dimensions (Scale: mm) .....	12
3.2 Panel Cutout (Scale: mm).....	12
3.3 CT (Current Transformer) External Dimensions (Scale: mm).....	13
3.4 Mounting to, and Removal from, the Control Panel .....	14
3.4.1 How to Mount the Unit.....	14
3.4.2 How to Remove the Mounting Bracket and Unit.....	15
4. Wiring .....	16
4.1 Terminal Arrangement.....	17
4.2 Lead Wire Solderless Terminal .....	18
4.3 When Using a Terminal Cover .....	18
4.4 Wiring .....	19
4.4.1 Power Supply .....	19
4.4.2 Control Output OUT1 and OUT2 .....	19
4.4.3 Input.....	20
4.4.4 Event Output EV1, EV2 and EV3.....	20
4.4.5 Insulated Power Output.....	20
4.4.6 Serial Communication .....	21
4.4.7 CT Input 1 and CT Input 2 .....	23
4.4.8 Transmission Output .....	24
4.4.9 Event Input DI1 and DI2 .....	24
5. Outline of Key Operation and Each Mode .....	26
5.1 Outline of Key Operation .....	26
5.2 Registering Settings and Selections.....	28
5.3 How to Read Setting Items .....	28
6. Initial Settings .....	29
7. Basic Settings and Operation .....	37
7.1 Procedure of Basic Settings and Operation .....	37
7.2 Program Pattern Setting .....	38
8. Explanation of Setting Items .....	43
8.1 Setting Items in Pattern Setting Mode .....	43
8.2 Setting Items in Event Setting Mode .....	48
8.3 Setting Items in Control Parameter Setting Mode .....	54
8.4 Setting Items in Wait Parameter Setting Mode.....	63
8.5 Setting Items in Engineering Setting Mode 1 .....	67
8.6 Setting Items in Engineering Setting Mode 2 .....	71
8.7 Clearing Data .....	85
9. Operation .....	86
9.1 Performing Program Control.....	86
9.1.1 Performing Program Control .....	86
9.1.2 Stopping Program Control.....	91
9.1.3 Suspending Program Control (Program Control Hold Function).....	92

9.1.4	Advancing Program Step (Advance Function) .....	93
9.1.5	Speeding up Program Step Time (Step Time Speed-up Function) .....	93
9.1.6	Changing Program Step SV and Step Time .....	94
9.1.7	Ending Program (Pattern End Function).....	94
9.2	Performing Fixed Value Control.....	95
9.2.1	Performing Fixed Value Control .....	95
9.2.2	Finishing Fixed Value Control .....	97
9.3	Switching Indication of the SV Display .....	98
9.4	Performing AT .....	99
9.4.1	Notice when Performing AT.....	99
9.4.2	AT Action .....	100
9.4.3	Performing AT.....	101
9.5	Input Value Correction .....	102
9.6	Items to be Initialized by Changing Settings .....	104
10.	Action Explanation.....	105
10.1	OUT1 Action.....	105
10.2	OUT1 ON/OFF Control Action .....	105
10.3	Heater Burnout Alarm Action .....	106
10.4	Alarm Action .....	107
10.5	OUT2 (Heating/Cooling Control) Action .....	109
10.6	OUT2 (Heating/Cooling Control) Action (When Setting Dead Band).....	110
10.7	OUT2 (Heating/Cooling control) Action (When Setting Overlap band) .....	111
11.	Specifications .....	112
11.1	Standard Specifications .....	112
11.2	Optional Specifications.....	126
12.	Troubleshooting.....	129
12.1	Indication.....	129
12.2	Key Operation .....	131
12.3	Control.....	132
13.	Character Table.....	133
13.1	Error Code .....	133
13.2	Pattern Setting Mode .....	134
13.3	Event Setting Mode .....	138
13.4	Control Parameter Setting Mode .....	140
13.5	Wait Parameter Setting Mode.....	143
13.6	Engineering Setting Mode 1 .....	145
13.7	Engineering Setting Mode 2 .....	147
13.8	Data Clear.....	154
14.	Making Program Pattern Table and Data Table .....	155
14.1	Making Program Pattern Table .....	155
14.2	Making Data Table .....	156
15.	Key Operation Flowchart.....	159

# 1. Model

## 1.1 Model

PCB1	<input type="checkbox"/>	<input type="checkbox"/>	0-	<input type="checkbox"/>	<input type="checkbox"/>	
Control output OUT1	R					Relay contact output
	S					Non-contact voltage output
	A					Direct current output
Power supply voltage	0					100 to 240 V AC
	1					24 V AC/DC
Input			0			Multi-range
Option 1			0			Option 1 not needed.
			1		EV2(DR) (*1)	Event output EV2, or Heating/Cooling control output OUT2 Relay contact output
			2		DS	Heating/Cooling control output OUT2 Non-contact voltage output
			3		DA	Heating/Cooling control output OUT2 Direct current output
			4		P24	Insulated power output
			5		EV3(DR) (*1), (*2)	Event output EV3 + Event output EV2, or Heating/Cooling control output OUT2 Relay contact output
			6		EV3DS (*2)	Event output EV3 + Heating/Cooling control output OUT2 Non-contact voltage output
			7		EV3DA (*2)	Event output EV3 + Heating/Cooling control output OUT2 Direct current output
Option 2			0			Option 2 not needed.
			1		C5W(20A) (*3)	Serial communication + Heater burnout alarm output + Event input (*4)
			2		C5W(100A) (*3)	Serial communication + Heater burnout alarm output + Event input (*4)
			3		EIW(20A) (*3)	Event input + Heater burnout alarm output
			4		EIW(100A) (*3)	Event input + Heater burnout alarm output
			5		EIT (*2)	Event input + Transmission output (4 – 20 mA DC)
			6		C5	Serial communication RS-485 + Event input (*4)
			7		W(20A) (*3)	Heater burnout alarm output
			8		W(100A) (*3)	Heater burnout alarm output
			9		EI	Event input + Event output EV3

(\*1) When 'Heating/Cooling control Relay contact output' is selected in [Event output EV2 allocation], it works as the DR option.

(\*2) The EV3D□ option and EIT option cannot be ordered together.

(\*3) When control output OUT1 is Relay contact output or Non-contact voltage output, the C5W, EIW or W option can be ordered.

(\*4) 'SV digital transmission' or 'SV digital reception' can be selected in [Communication protocol].

## 1.2 How to Read the Model Label

The model label is attached to the right side of the case.

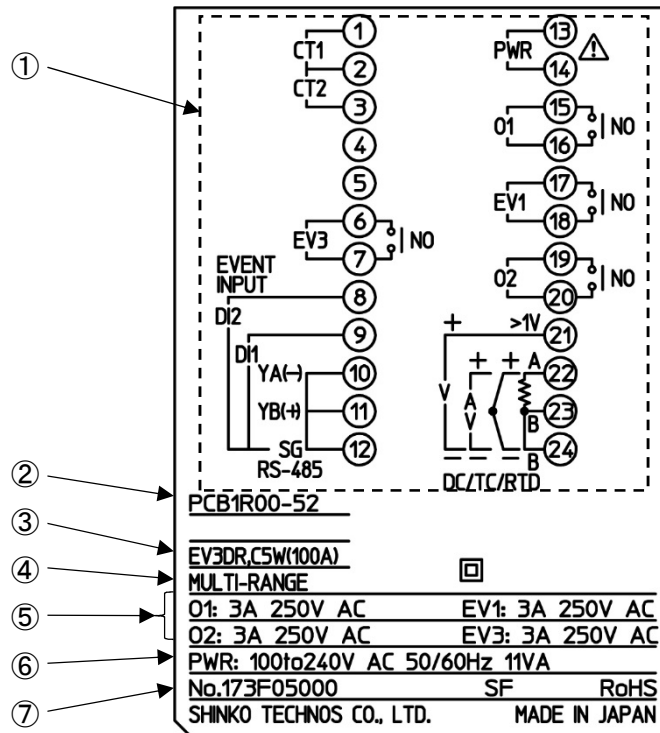

(Fig. 1.2-1)

No.	Description	Example
①	Terminal arrangement	Terminal arrangement of PCB1R00-52 (*1)
②	Model	PCB1R00-52
③	Option	EV3DR (Event output EV3 + Event output EV2, or Heating/Cooling control output OUT2 Relay contact output) C5W(100A) [Serial communication + Heater burnout alarm output (100 A) + Event input] (*2)
④	Input	MULTI-RANGE (Multi-range input)
⑤	Control output, Event output	O1: 3 A 250 V AC (Control output OUT1) EV1: 3 A 250 V AC (Event output EV1) O2: 3 A 250 V AC (Control output OUT2) EV3: 3 A 250 V AC (Event output EV3)
⑥	Power supply, Power consumption	100 to 240 V AC 50/60 Hz, 11 VA
⑦	Serial number	No. 173F05000

(\*1) Terminal arrangement diagram differs depending on the model.

(\*2) For Heater burnout alarm output (C5W, EIW, W options), CT rated current is entered in bracket ( ).



## 2. Name and Functions of Controller

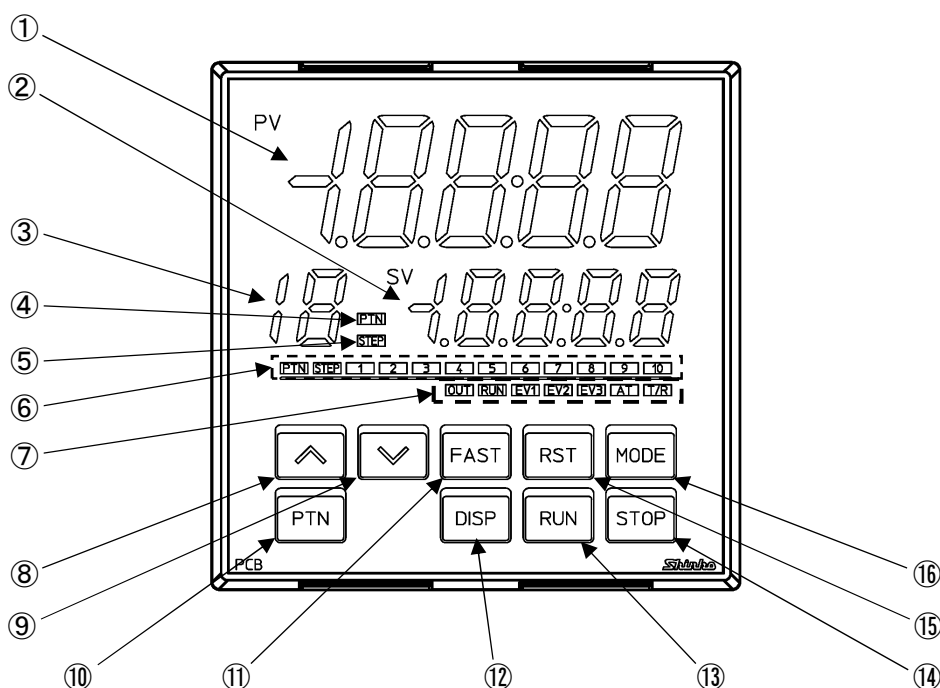

(Fig. 2-1)

### Display, Indicator

No.	Name	Description
①	<b>PV Display (Red)</b>	Indicates process variable (PV) in RUN mode. Indicates setting characters in Setting mode. Flashes during Wait action or Program control Hold in program control.
②	<b>SV Display (Green)</b>	Indicates the desired value (SV), Output manipulated variable (MV), or Remaining time (TIME) in RUN mode. Retains display indication at power OFF. Indicates the set values in setting mode.
③	<b>PTN/STEP Display (Orange)</b>	Indicates the pattern number or step number. Each time the <b>[DISP]</b> key is pressed, the PTN/STEP Display (③), and the PTN/STEP indicator (⑥) alternately indicate the pattern number and step number. Flashes during Wait action or when the step number is indicated. If 'SV digital reception' is selected in [Communication protocol], <b>r</b> is indicated.
④	<b>PTN indicator (Orange)</b>	Lights up when the pattern number is indicated on the PTN/STEP Display.
⑤	<b>STEP indicator (Orange)</b>	Lights up when the step number is indicated on the PTN/STEP Display.
⑥	<b>PTN/STEP indicator (Green)</b>	LED for the pattern number or step number lights up. If the PTN/STEP Display (③) indicates the pattern number, the PTN/STEP indicator (⑥) lights up its step number. If the PTN/STEP Display indicates the step number, the PTN/STEP indicator lights up its pattern number. Each time the <b>[DISP]</b> key is pressed, the PTN/STEP indicator and the PTN/STEP Display alternately indicate the pattern number and step number.

## Action Indicator

No.	Name	Description
⑦	<b>OUT (Green)</b>	Lights up when control output OUT1 is ON. For direct current output, flashes corresponding to the MV in 125 ms cycles.
	<b>RUN (Orange)</b>	Lights up during program control RUN. Flashes during Program control HOLD or Fixed value control.
	<b>EV1 (Red)</b>	Lights up when Event output EV1 is ON.
	<b>EV2 (Red)</b>	Lights up when Event output EV2 [(EV2, EV3(DR) options] is ON. Lights up when control output OUT2 [Cooling output (EV2, DS, DA or EV3D□ option)] is ON. For direct current output (DA, EV3DA options), flashes corresponding to the MV in 125 ms cycles.
	<b>EV3 (Red)</b>	Lights up when Event output EV3 (EV3D□, EI options) is ON.
	<b>AT (Orange)</b>	Flashes while AT is performing.
	<b>T/R (Orange)</b>	Lights up during serial communication (C5W, C5 options) TX (transmitting) output.

## Key

No.	Name	Description
⑧	<b>UP key</b>	In setting mode, increases the numerical value. By pressing for approx. 1 second during program control RUN, time progress pauses, and control continues with the SV at that time (Program control Hold function).
⑨	<b>DOWN key</b>	In setting mode, decreases the numerical value.
⑩	<b>PTN key (Pattern key)</b>	During program control STOP (in Standby), selects program pattern number to perform or to set. By pressing during program control RUN, moves to Monitor mode. In Monitor mode, switches the indication items.
⑪	<b>FAST key</b>	In setting mode, makes the numeric value change faster. During program control RUN, makes step time progress 60 times faster.
⑫	<b>DISP key (Display key)</b>	During RUN mode, the PTN/STEP display and PTN/STEP indicator alternately indicates the pattern number and step number. In setting mode, registers the setting data, and moves back to the previous setting item.
⑬	<b>RUN key</b>	Performs program control, or cancels Control Hold while program control is held. By pressing for approx. 1 second during program control RUN, stops performing step, and proceeds to the next step (Advance function).
⑭	<b>STOP key</b>	Stops program control by pressing for approx. 1 second during program control RUN. Cancels pattern end output.
⑮	<b>RST key (Reset key)</b>	In setting mode, registers the setting data, and moves to RUN mode.
⑯	<b>MODE key</b>	In setting mode, registers the setting data, and moves to the next setting item.

**Tool cable**  
CMD-001

**Top view of the case**

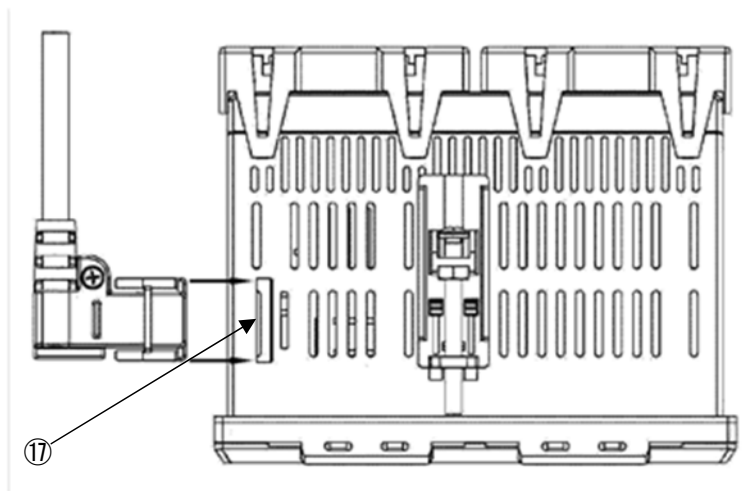

(Fig. 2-2)

**Connector**

No.	Name	Description
⑰	<b>Tool cable connector</b>	<p>By connecting the Tool cable (CMD-001, sold separately), the following operations can be conducted from an external computer, using the Console software SWC-PCB101M.</p> <p>Tool cable connector is at the top of the instrument.</p> <ul style="list-style-type: none"> <li>• Reading and writing of step SV, step time, PID and various set values</li> <li>• Reading of PV and action status</li> <li>• Function change</li> </ul>

# 3. Mounting to the Control Panel

## 3.1 External Dimensions (Scale: mm)

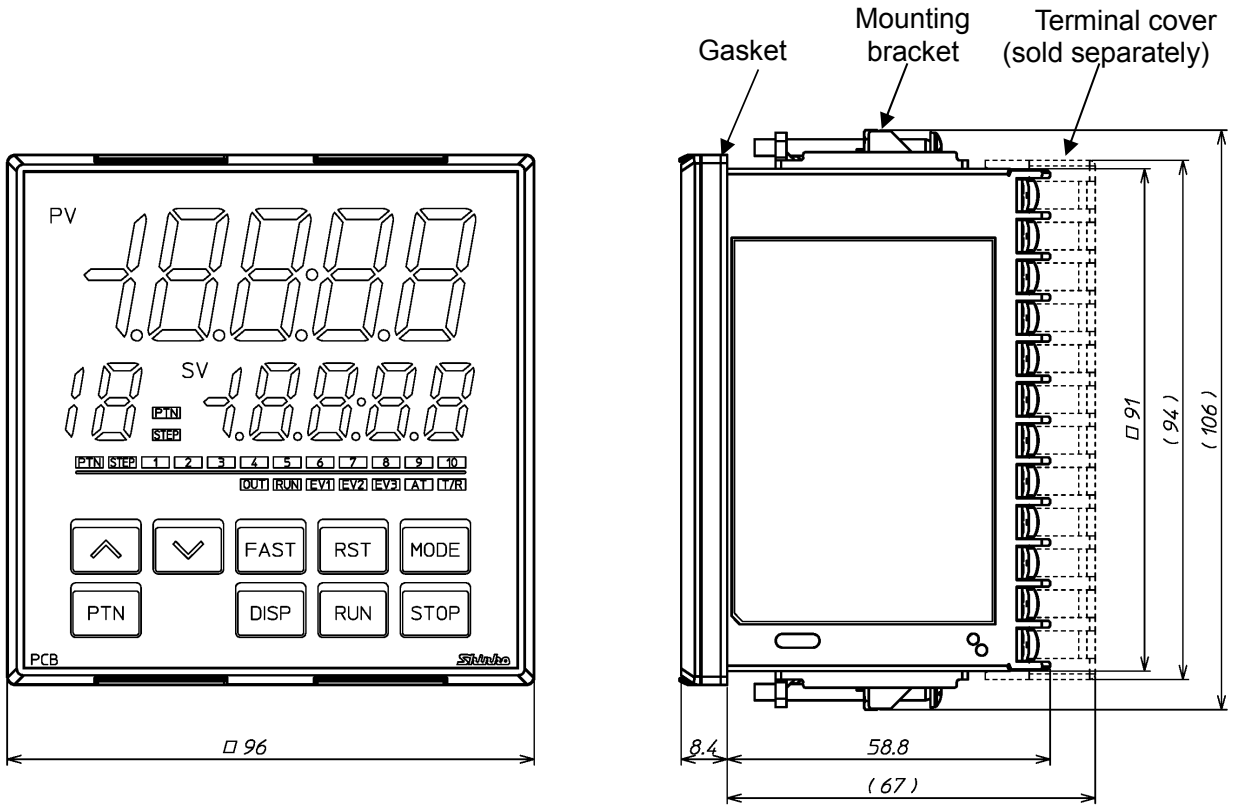

( ): Size when mounting brackets or terminal cover (sold separately) are mounted.

(Fig. 3.1-1)

## 3.2 Panel Cutout (Scale: mm)

**⚠ Caution**

If horizontal close mounting is used for the controller, IP66 specification (Drip-proof/Dust-proof) may be compromised, and all warranties will be invalidated.

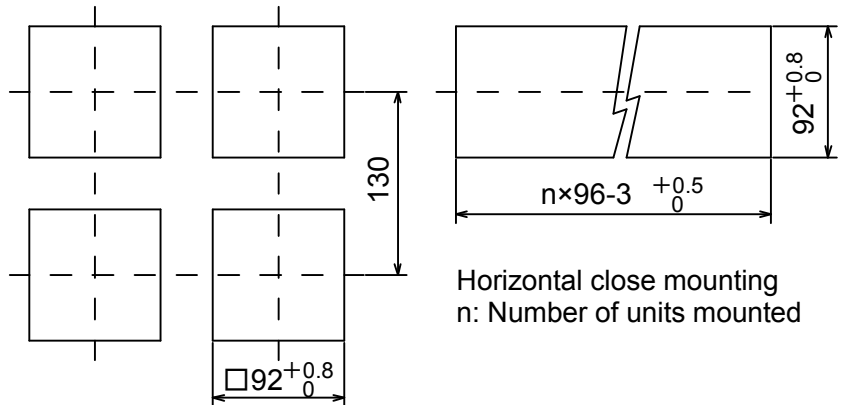

(Fig. 3.2-1)

**3.3 CT (Current Transformer) External Dimensions (Scale: mm)**

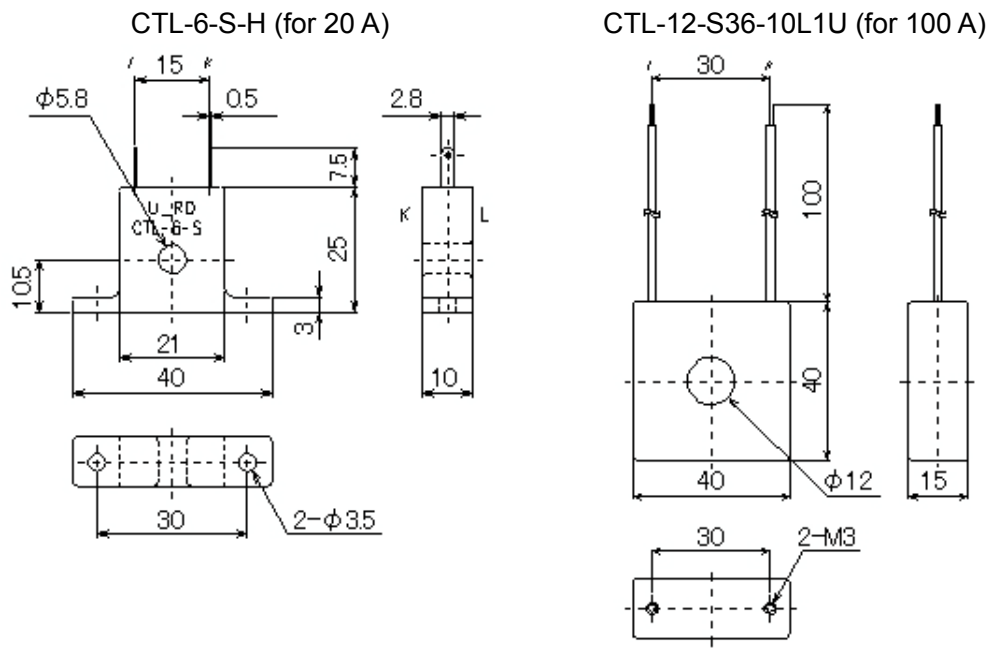

(Fig. 3.3-1)

### 3.4 Mounting to, and Removal from, the Control Panel



## Caution

As the case of the PCB1 is made of resin, do not use excessive force while tightening screws, or the case and mounting brackets could be damaged.

The torque should be 0.1 N·m.

#### 3.4.1 How to Mount the Unit

Mount the controller vertically to the flat, rigid panel to ensure it adheres to the Drip-proof/Dust-proof specification (IP66).

If the horizontal close mounting is used for the controller, IP66 specification (Drip-proof/Dust-proof) may be compromised, and all warranties will be invalidated.

Mountable panel thickness: 1 to 7 mm

(1) Insert the controller from the front side of the control panel. (Fig. 3.4.1-1)

If the Drip-proof/Dust-proof specification (IP66) is not necessary, the gasket may be removed.

(Please keep in mind the warranty is void if gasket is removed).

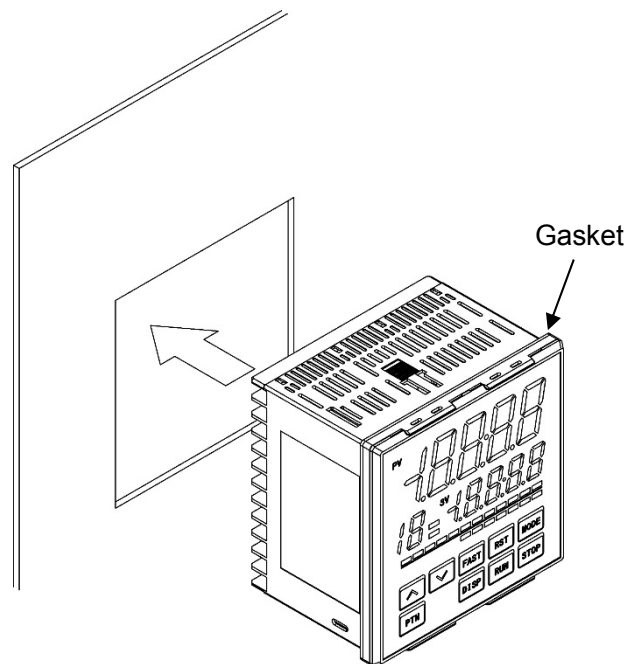

(Fig. 3.4.1-1)

- (2) Attach the mounting brackets into the slots at the top and bottom of the case, and secure the controller in place with the screws. (Fig. 3.4.1-2)

The torque is 0.1 N•m.

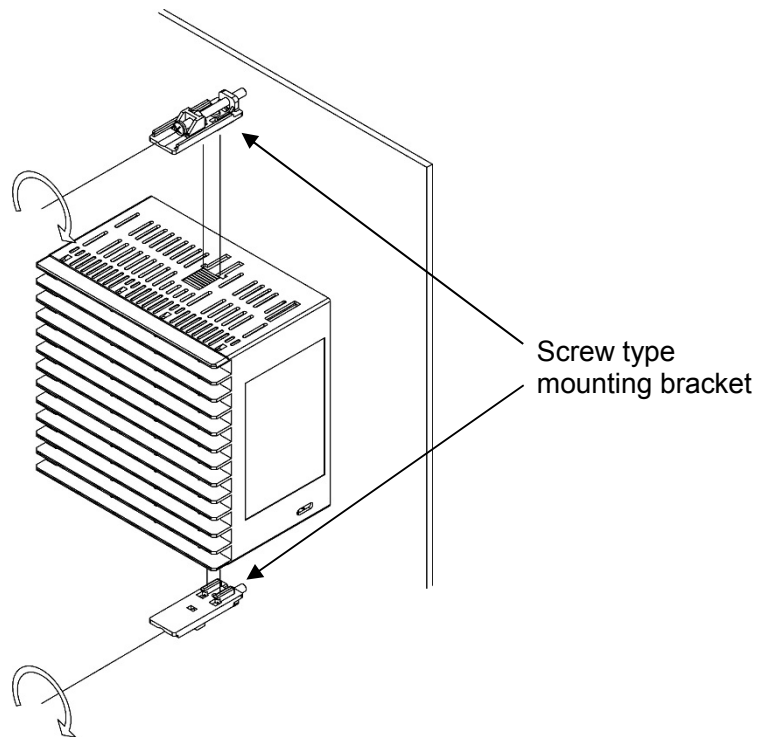

(Fig. 3.4.1-2)

### 3.4.2 How to Remove the Mounting Bracket and Unit

- (1) Turn the power to the unit OFF, and disconnect all wires before removing the unit.
- (2) Loosen the screws of the mounting brackets, and remove the mounting brackets.
- (3) Pull the unit out from the front of the control panel.

## 4. Wiring



### Warning

Turn the power supply to the instrument off before wiring or checking.

Working on or touching the terminal with the power switched on may result in severe injury or death due to electrical shock.



### Caution

- Do not leave wire remnants in the instrument, as they could cause a fire or malfunction.
- Use the solderless terminal with an insulation sleeve in which the M3 screw fits when wiring the instrument.
- The terminal block of this instrument is designed to be wired from the left side. The lead wire must be inserted from the left side of the terminal, and fastened with the terminal screw.
- Tighten the terminal screw using the specified torque. If excessive force is applied to the screw when tightening, the terminal screw or case may be damaged.
- Do not pull or bend the lead wire on the terminal side when wiring or after wiring, as it could cause malfunction.
- This instrument does not have a built-in power switch, circuit breaker and fuse. It is necessary to install a power switch, circuit breaker and fuse near the controller.  
(Recommended fuse: Time-lag fuse, rated voltage 250 V AC, rated current 2 A)
- For a 24 V AC/DC power source, do not confuse polarity when using direct current (DC).
- Do not apply a commercial power source to the sensor which is connected to the input terminal nor allow the power source to come into contact with the sensor.
- Use a thermocouple and compensating lead wire according to the sensor input specifications of this controller.
- Use the 3-wire RTD according to the sensor input specifications of this controller.
- For DC voltage input, (+) side input terminal number of 0 to 5 V DC, 1 to 5 V DC, 0 to 10 V DC differs from that of 0 to 1 V DC.

Terminal Number	DC Voltage Input
②①	(+) side of 0 to 5 V DC, 1 to 5 V DC, 0 to 10 V DC
②②	(+) side of 0 to 1 V DC

- When using a relay contact output type, externally use a relay according to the capacity of the load to protect the built-in relay contact.
- When wiring, keep input wires (thermocouple, RTD, etc.) away from AC power sources or load wires.



### 4.1 Terminal Arrangement

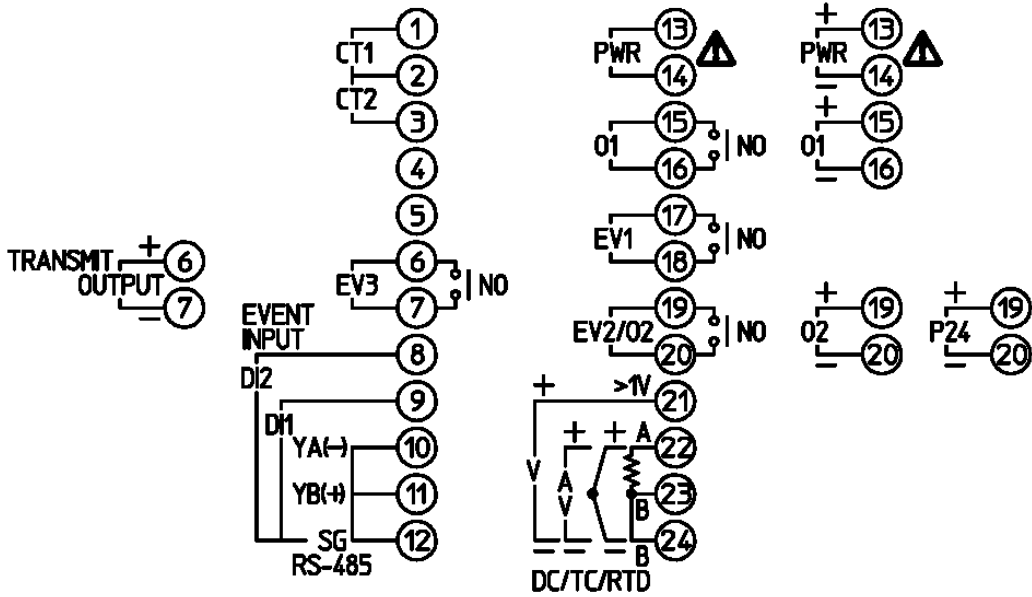

(Fig. 4.1-1)

Terminal Code	Description
PWR	Supply voltage 100 to 240 V AC or 24 V AC/DC <b>(For 24 V DC, ensure polarity is correct.)</b>
O1	Control output OUT1
EV1	Event output EV1
EV2	Event output EV2 [EV2, EV3(DR) options]
O2	Control output OUT2 (EV2, DS, DA, EV3D□ options)
P24	Insulated power output 24 V DC (P24 option)
TC	Thermocouple input
RTD	RTD input
DC	Direct current, DC voltage input
CT1	CT (current transformer) input 1 (C5W, EIW, W options)
CT2	CT (current transformer) input 2 (C5W, EIW, W options)
RS-485	Serial communication RS-485 (C5W, C5 options)
EVENT INPUT	Event input DI1 (C5W, EIW, EIT, C5, EI options) Event input DI2 (C5W, EIW, EIT, C5, EI options)
EV3	Event output EV3 (EV3D□, EI options)
TRANSMIT OUTPUT	Transmission output (EIT option)

#### 4.2 Lead Wire Solderless Terminal

Use a solderless terminal with an insulation sleeve in which an M3 screw fits as shown below. The torque should be 0.63 N·m.

Solderless Terminal	Manufacturer	Model	Tightening Torque
Y-type	Nichifu Terminal Industries Co., Ltd.	TMEV1.25Y-3	0.63 N·m
	Japan Solderless Terminal MFG Co., Ltd.	VD1.25-B3A	
Ring-type	Nichifu Terminal Industries Co., Ltd.	TMEV1.25-3	
	Japan Solderless Terminal MFG Co., Ltd.	V1.25-3	

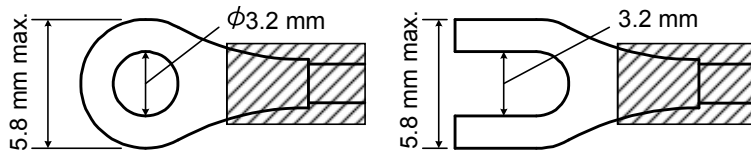

(Fig. 4.2-1)

#### 4.3 When Using a Terminal Cover

When using a terminal cover (sold separately), make sure the longer side is on the back left and right side of the case.

Pass the wires from terminal numbers 13 to 24 between terminal covers.

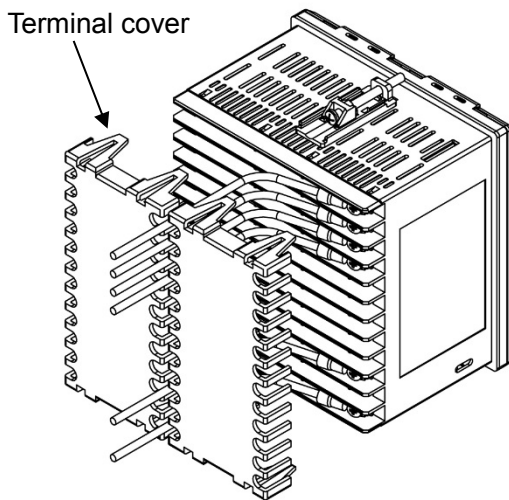

(Fig. 4.3-1)

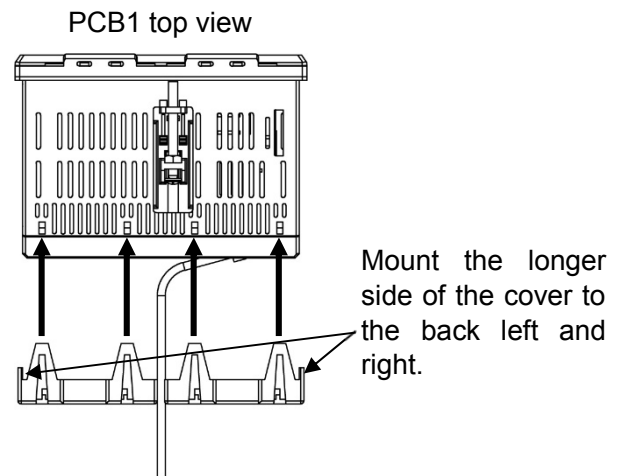

(Fig. 4.3-2)

#### 4.4 Wiring

For the terminal arrangement, refer to Section '4.1 Terminal Arrangement' (p.17).

##### 4.4.1 Power Supply

Power supply voltage is 100 to 240 V AC or 24 V AC/DC.

**For a 24 V AC/DC power source, ensure polarity is correct when using direct current (DC).**

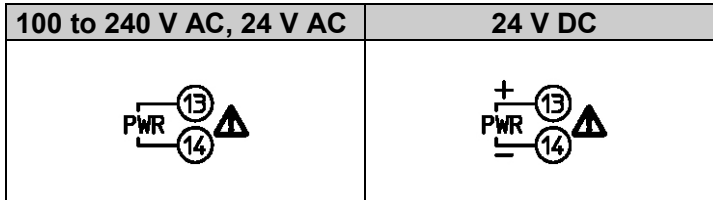

##### 4.4.2 Control Output OUT1 and OUT2

When EV2, DS, DA or EV3D□ option is ordered, control output OUT2 is available.

Specifications of Control output OUT1 and OUT2 are shown below.

<b>Relay contact</b>	1a Control capacity: 3 A 250 V AC (resistive load), 1 A 250 V AC (inductive load $\cos\phi=0.4$ ) Electrical life: 100,000 cycles Minimum applicable load: 10 mA 5 V DC
<b>Non-contact voltage (for SSR drive)</b>	12 V DC $\pm 15\%$ Max. 40 mA (short circuit protected)
<b>Direct current</b>	4 to 20 mA DC Load resistance: Max. 550 $\Omega$

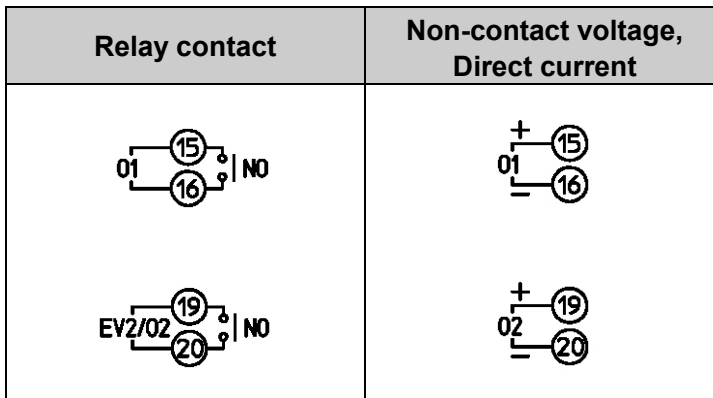

Number of Shinko SSR units when connected in parallel (for Non-contact voltage output):

- SA-400 series: 5 units
- SA-500 series: 2 units

### 4.4.3 Input

Each input wiring is shown below.

**Note:** For DC voltage input, (+) side input terminal number of 0 to 5 V DC, 1 to 5 V DC, 0 to 10 V DC differs from that of 0 to 1 V DC.

Thermocouple	RTD	Direct current, DC voltage (0 to 1 V)	DC voltage (0 to 5 V, 1 to 5 V, 0 to 10 V)

### 4.4.4 Event Output EV1, EV2 and EV3

Event output EV1 is a standard feature.

Event output EV2 is available when EV2 or EV3(DR) option is ordered.

Event output EV3 is available when EV3D□ or EI option is ordered.

Specifications of Event output EV1, EV2 and EV3 are shown below.

<b>Relay contact</b>	1a Control capacity: 3 A 250 V AC (resistive load) 1 A 250 V AC (inductive load $\cos\phi=0.4$ ) Electrical life: 100,000 cycles Minimum applicable load: 10 mA 5 V DC
----------------------	--

Event Output EV1	Event Output EV2	Event Output EV3

### 4.4.5 Insulated Power Output

If P24 option is ordered, the Insulated power output is available.

Specifications of Insulated power output are shown below.

<b>Output voltage</b>	24 ± 3 V DC (When load current is 30 mA DC)
<b>Ripple voltage</b>	Within 200 mV DC (When load current is 30 mA DC)
<b>Max. load current</b>	30 mA DC

Insulated Power Output

#### 4.4.6 Serial Communication

If the C5W or C5 option is ordered, Serial communication is available.

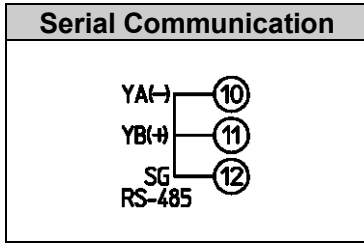

##### (1) Serial Communication

- When using USB communication cable CMC-001-1 (sold separately)

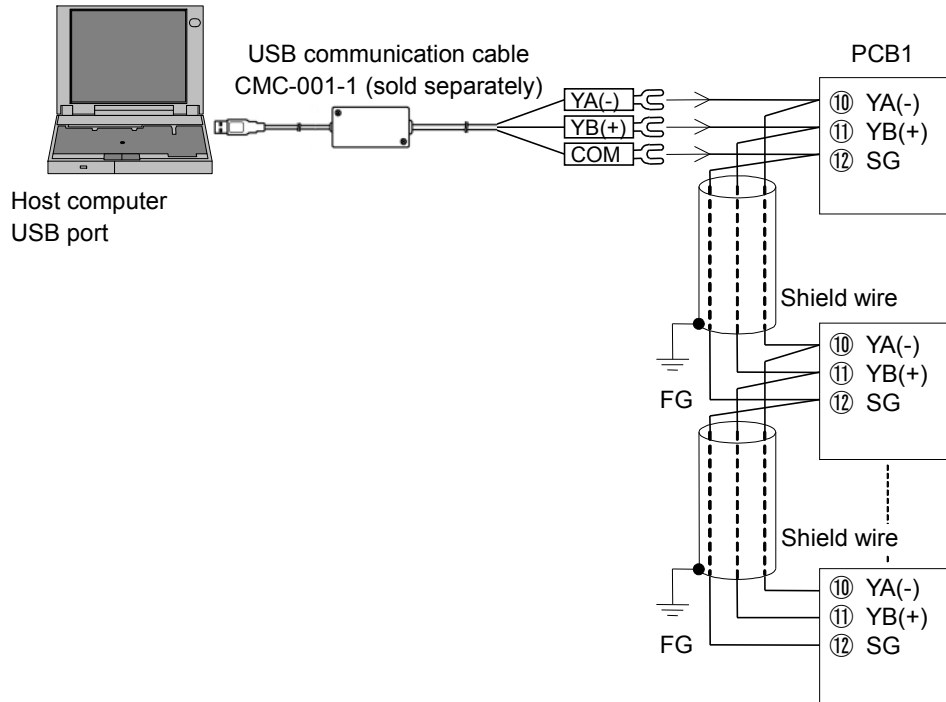

(Fig. 4.4.6-1)

- When using communication converter IF-400 (sold separately)

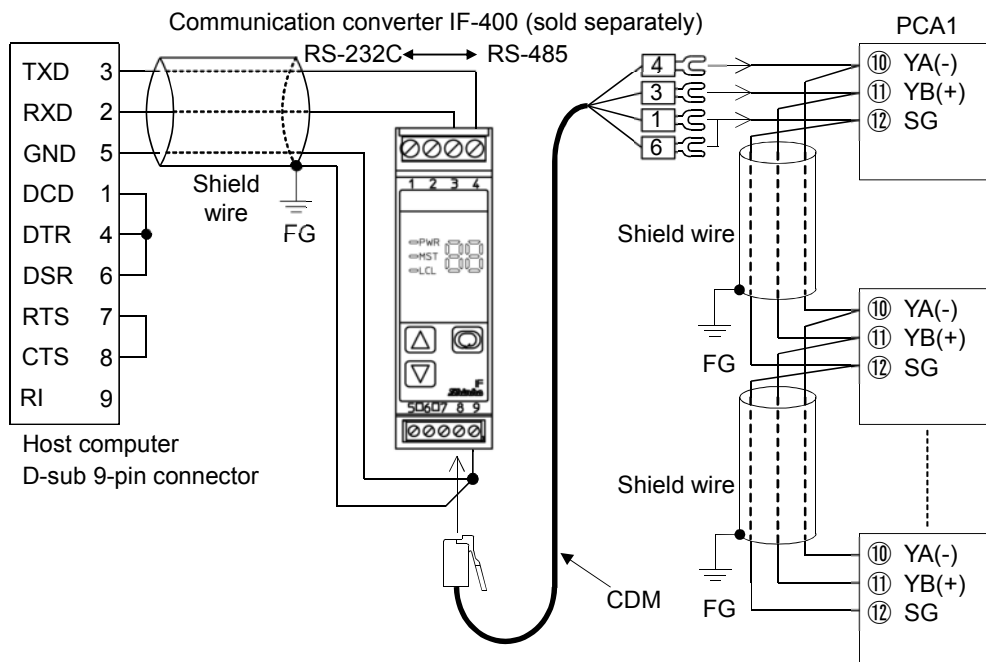

(Fig. 4.4.6-2)

## (2) SV digital transmission

If 'SV digital transmission' is selected in [Communication protocol]:

Step SV can be digitally transmitted to the connected Shinko indicating controllers with the SV digital transmission (C5 option) function.

If 'SV digital reception' is selected in [Communication protocol]:

Receives digital SV via SVTC command from the connected Shinko programmable controllers.

Shinko programmable controllers:

PC-900, PCD-33A [When the SVTC (SV digital transmission) option is ordered]

PCA1, PCB1 (When 'SV digital transmission' is selected in [Communication protocol])

Update cycle: 250 ms

## Wiring

For the PCB1 and controllers with the communication function, connect YA (-) to YA (-), YB (+) to YB (+), SG to SG terminal respectively.

Up to 31 units can be connected.

## Wiring example of PCB1 and controllers with communication function

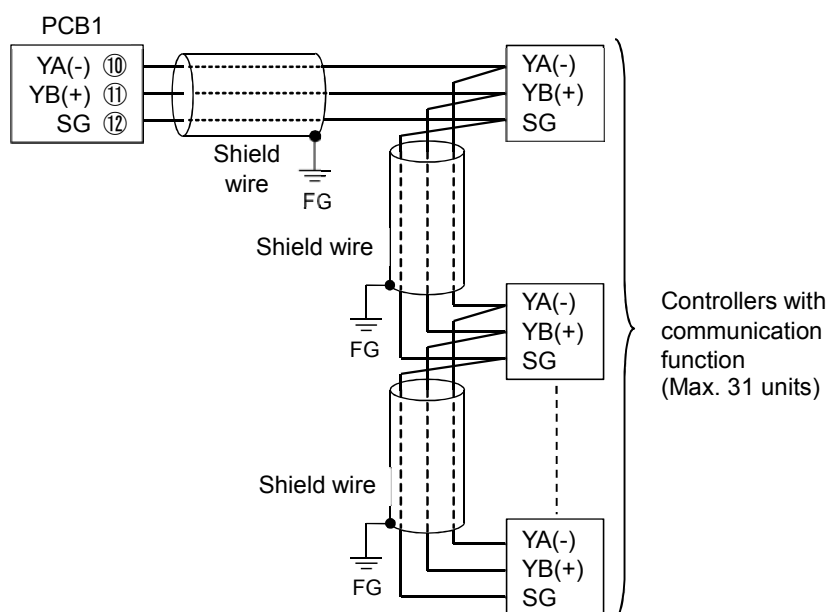

(Fig. 4.4.6-3)

## Shield wire

Connect only one end of the shield to the FG terminal to avoid a ground loop. If both ends of the shield wire are connected to the FG terminal, the circuit will be closed, resulting in a ground loop. This may cause noise.

Be sure to ground the FG terminal.

Recommended cable: OTSC-VB 2PX0.5SQ (made by Onamba Co., Ltd.) or equivalent (Use a twisted pair cable.)

#### 4.4.7 CT Input 1 and CT Input 2

Current Transformer (CT) input is available when Heater burnout alarm output (C5W, EIW, W options) is ordered.

Cannot be used for detecting heater current under phase control.

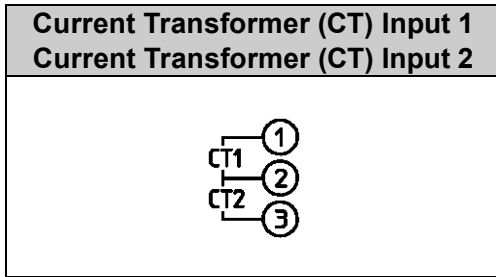

Use the CT (current transformer) provided, and pass one lead wire of the heater circuit into the hole of the CT. (Fig. 4.4.7-1)

When wiring, keep the CT wire away from AC sources or load wires to avoid the external interference.

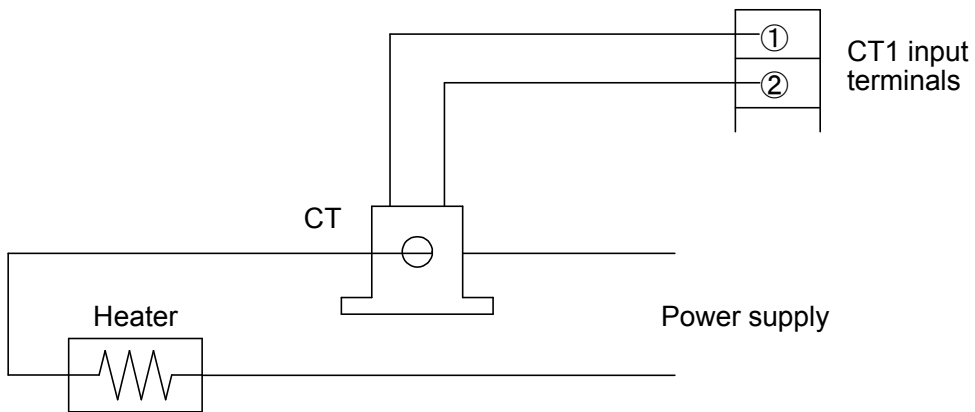

(Fig. 4.4.7-1)

When using 3-phase, pass any 2 lead wires of R, S, T into the CT, and connect them to CT1 (①-②) and CT2 (②-③) terminals. (Fig. 4.4.7-2)

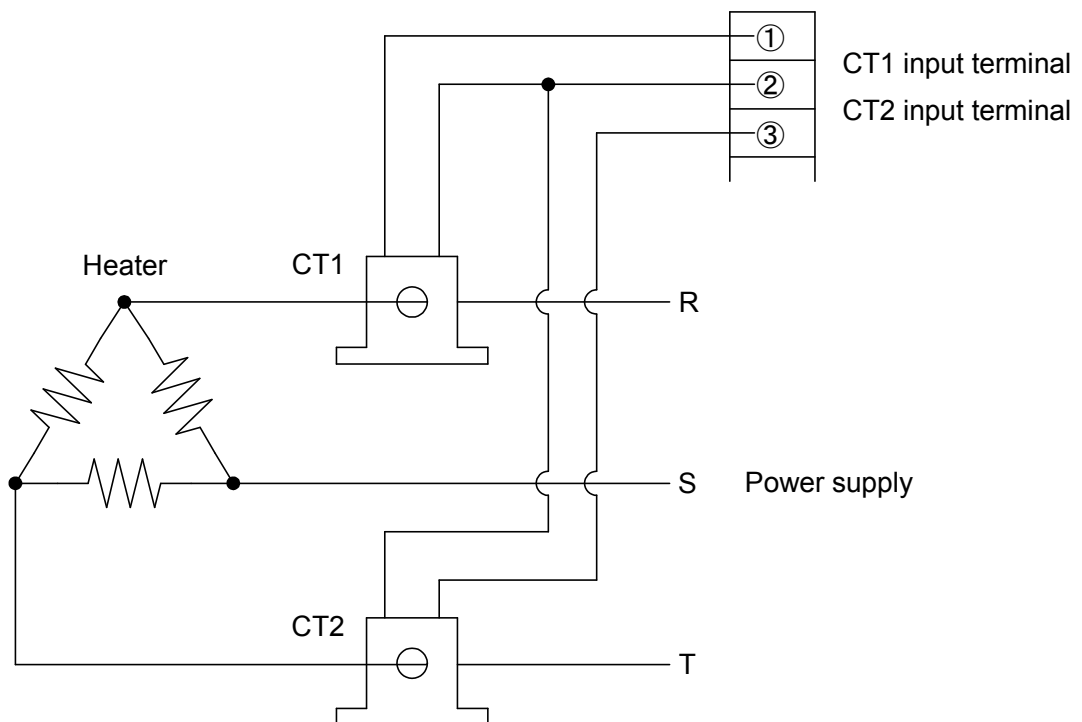

(Fig. 4.4.7-2)

#### 4.4.8 Transmission Output

If the EIT option is ordered, Transmission output is available.

Specifications of Transmission output are shown below.

<b>Resolution</b>	12000
<b>Output</b>	4 to 20 mA DC Load resistance: Max. 550 Ω
<b>Output accuracy</b>	Within ±0.3% of Transmission output span
<b>Response time</b>	400 ms + Input sampling period (0%→90%)

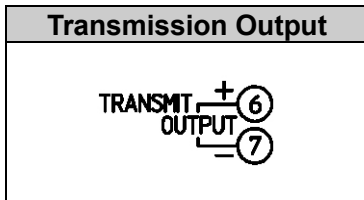

Converting the value (PV, SV or MV transmission) to analog signal every 125 ms, outputs the value in current. (Factory default: PV transmission)

Outputs Transmission output low limit value if Transmission output high limit and low limit value are the same.

If SV or MV transmission is selected, 4 mA is output while in program control STOP (in Standby).

#### 4.4.9 Event Input DI1 and DI2

When C5W, EIW, EIT, C5 or EI option is ordered, Event input DI1 or Event input DI2 is available.

Specifications of Event input are shown below.

<b>Circuit current when closed</b>	Approx. 16 mA
------------------------------------	---------------

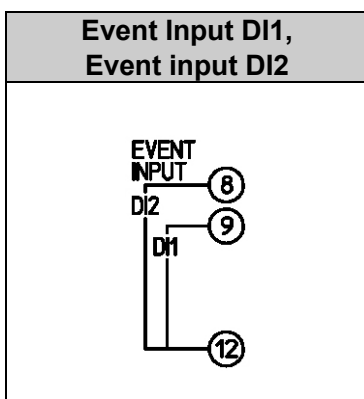

Signal edge action from OFF to ON / ON to OFF is engaged. However, when the power is turned ON, level action is used except Program control Advance function.

If any function except 'Pattern number selection' is selected in [Event input DI1/DI2 allocation], OR calculation [if any one is ON (Closed), the function activates] begins.

An action changed by Event input DI□ has priority.



If 'Pattern number selection' is selected in [Event input DI1/DI2 allocation], Patterns 2 to 4 can be selected by ON (Closed) or OFF (Open) status of Event input DI1 and DI2.

Pattern numbers selected by Event input have priority over pattern numbers selected by keypad operation.

To select pattern numbers by keypad, make sure all Event inputs are in OFF (Open) status.

- When 'Pattern number selection' is selected only for Event input DI1:

Pattern number	*	2
Event input DI1	OFF (Open)	ON (Closed)

\* This number will be selected by keypad operation.

- When 'Pattern number selection' is selected for both Event input DI1 and DI2:

Pattern number	*	2	3	4
Event input DI1	OFF (Open)	ON (Closed)	OFF (Open)	ON (Closed)
Event input DI2	OFF (Open)	OFF (Open)	ON (Closed)	ON (Closed)

\* This number will be selected by keypad operation.

# 5. Outline of Key Operation and Each Mode

## 5.1 Outline of Key Operation

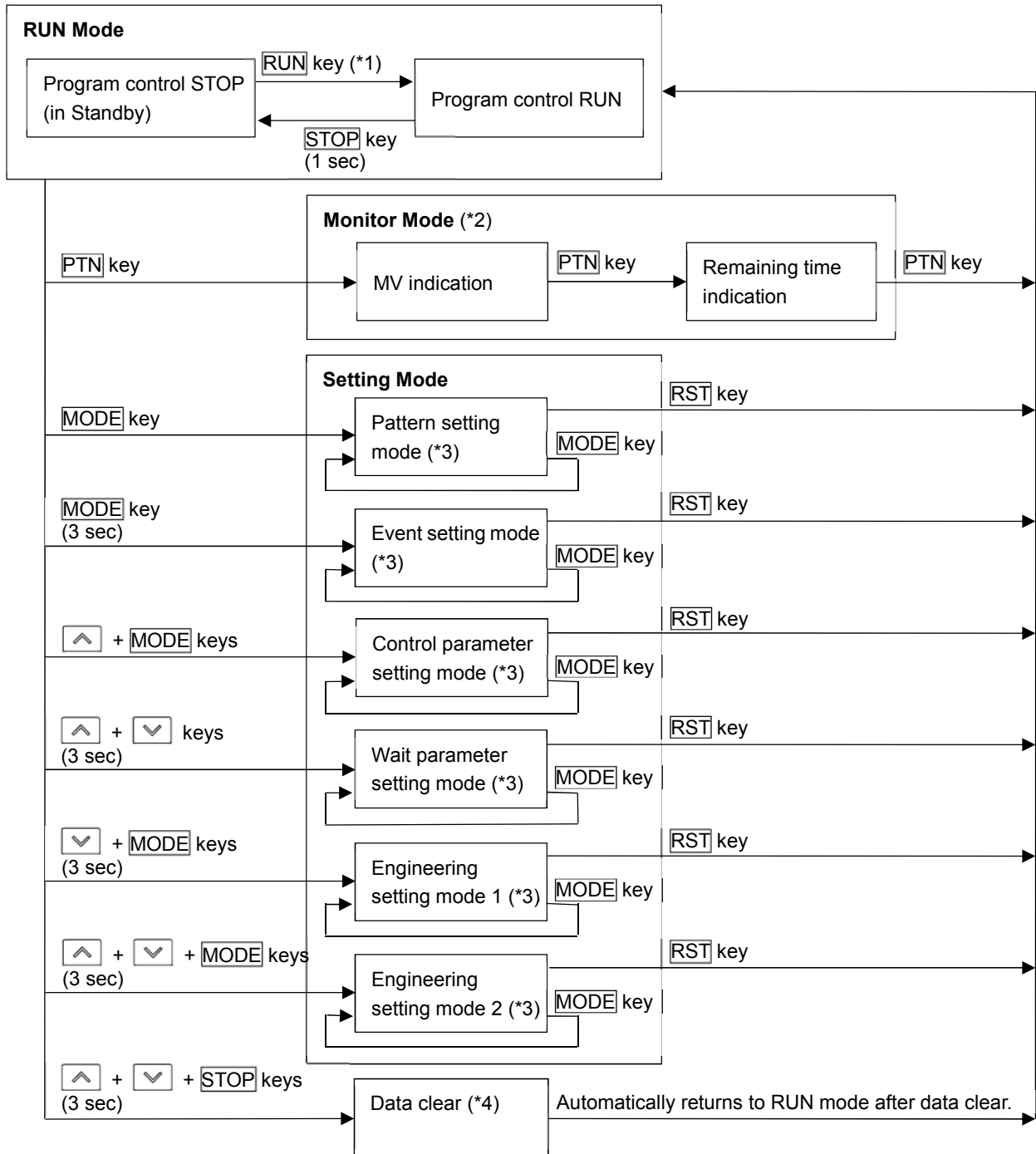

- (\*1) Select a pattern number with the **PTN** key, and press the **RUN** key. Program control will start.
- (\*2) Effective during Program control RUN.
- (\*3) If the **MODE** key is pressed, settings or selections are registered, and moves to the next setting item.  
 If the **MODE** key is pressed at the last setting item in each setting mode, the unit returns to the 1st setting item.  
 If the **DISP** key is pressed, settings or selections are registered, and moves back to the previous setting item.  
 If the **DISP** key is pressed at the 1st setting item in each setting mode, the unit moves back to the last setting item.
- (\*4) Effective during program control STOP (in Standby).



(Fig. 5.1-1)



## Modes



Mode	Description	
<b>RUN mode</b>	If power is turned ON, the unit enters RUN mode. Starts from Program control STOP (in Standby) or Program control RUN, depending on the status at power OFF. Indication differs depending on the status below.	
	Program control STOP (in Standby)	The PV Display indicates PV. The PTN indicator or STEP indicator lights up. While the PTN indicator is lit, the PTN/STEP Display indicates the pattern number. While the STEP indicator is lit, the PTN/STEP Display is unlit. Other Displays and indicators are unlit.
	Program control RUN	The PV Display indicates PV. The SV Display indicates SV, MV or remaining time. The PTN indicator or STEP indicator lights up. While the PTN indicator is lit, the PTN/STEP Display indicates the pattern number. STEP of the PTN/STEP indicator lights up. While the STEP indicator is lit, the PTN/STEP Display indicates the step number. PTN of the PTN/STEP indicator lights up. Action indicators light up depending on the operation status.
<b>Monitor mode</b>	By pressing the <b>PTN</b> key during program control RUN, the unit enters Monitor mode. The PV Display indicates PV, and the SV Display indicates MV. Each time the <b>PTN</b> key is pressed, SV, MV or remaining time is indicated.	
<b>Setting mode</b>	Pattern setting mode	Sets the following: Step SV, Step time, PID block number, number of repetitions and pattern link.
	Event setting mode	Sets the following: EV□ alarm value, Time signal TS1 output OFF time, Time signal TS1 output ON time
	Control parameter setting mode	Sets the following: AT Perform/Cancel, OUT1 proportional band, Integral time, Derivative time, ARW, OUT2 proportional band (When EV2, DS, DA or EV3D□ option is ordered), Direct/Reverse action, Loop break alarm, etc.
	Wait parameter setting mode	Sets the following: Wait value, Wait function Enabled/Disabled for each step
	Engineering setting mode 1	Sets the following: Set vlaue lock, Sensor correction, PV filter time constant, Communication parameters (When C5W or C5 option is ordered)
	Engineering setting mode 2	Sets the following: Input type, Scaling high limit, Scaling low limit, Event output EV□ allocation, Step time unit, Power restore action, etc.
<b>Data clear</b>	By pressing the <b>▲</b> , <b>▼</b> and <b>STOP</b> keys (in that order) together for approx. 3 seconds during program control STOP (in Standby), Data clear Yes/No appears. To clear data, select YES, and press the <b>MODE</b> key. The PV Display indicates <b>! r!</b> for approx. 3 seconds, and all data reverts to their factory default values.	

## 5.2 Registering Settings and Selections

### • How to increase/decrease setting values

To increase or decrease the set value (numeric value), use the  or  key.

If the  or  key is pressed with the **FAST** key simultaneously, makes the numeric value change faster.

To switch the selection items, use the  or  key.

### • How to register setting data or selection data

To register the settings or selections, use the **MODE** or **DISP** key.

If the **MODE** key is pressed, the set values (numerical values) or selected item are registered, and moves to the next setting item.

If the **MODE** key is pressed at the last setting item, the unit returns to the 1st setting item.

If the **DISP** key is pressed, the set values (numerical values) or selected item are registered, and moves back to the previous setting item.

If the **DISP** key is pressed at the 1st setting item, the unit moves back to the last setting item.

### • How to return to RUN mode

To return to RUN mode, use the **RST** key.

If the **RST** key is pressed, the set values (numerical values) or selected item will be registered, and the unit will revert to RUN mode.

## 5.3 How to Read Setting Items

Step 1 SV will be used for the explanation.

Explanation of setting items:

- Upper left: PV Display: Indicates setting characters.

- Lower left: PTN/STEP Display, SV Display

The PTN/STEP Display indicates the pattern number or step number. Indication differs depending on the setting item.

The SV Display indicates factory default value.

- Right side: Indicates the setting item or selection item, explanation of its function and setting range (or selection items).

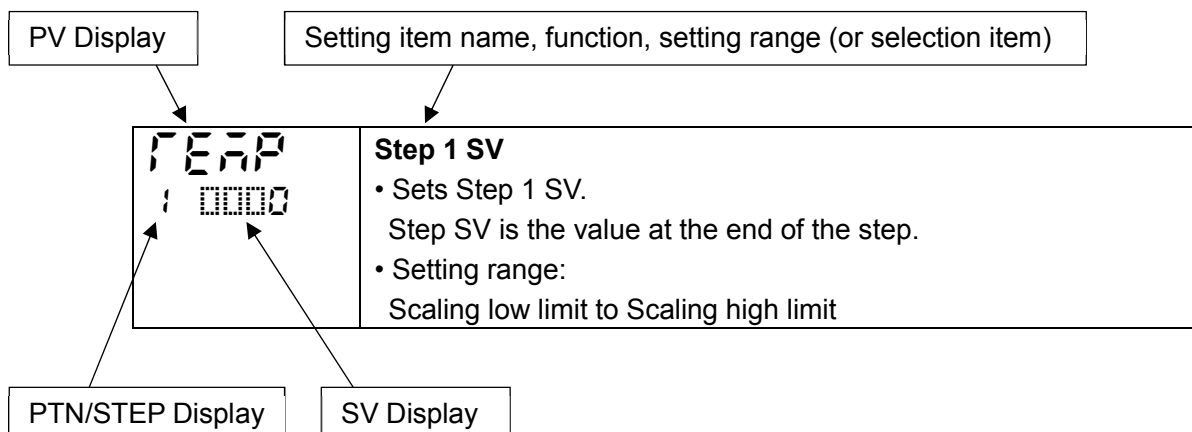

# 6. Initial Settings

Setup (setting the Input type, Scaling high limit, Scaling low limit, Event output EV1 allocation, Step time unit, Power restore action, Direct/Reverse action, etc.) should be done before using this controller, according to the user's conditions.

Perform setup (or initial settings) in Engineering setting mode 2 and Control parameter setting mode.

Initial setting items and their factory default values are shown below in (Table 6-1).

If the user's specification is the same as the factory default value of this instrument, or if user's instrument has already been installed in a system after initial settings are finished, initial settings are not necessary.



Proceed to Section "7. Basic Settings and Operation" (p.37).

(Table 6-1)

Initial Setting Item	Factory Default
<b>Engineering setting mode 2</b>	
Input type	K -200 to 1370°C
Scaling high limit	1370°C
Scaling low limit	-200°C
Decimal point place	No decimal point
Event output EV1 allocation	No event
Step time unit	Hours : Minutes
Power restore action	Stops after power is restored.
Step SV when program control starts	0°C
Program control start type	PV start
<b>Control parameter setting mode</b>	
OUT1 proportional cycle	Relay contact output: 30 sec Non-contact voltage output: 3 sec
Direct/Reverse action	Reverse action



The following shows the procedure for initial settings.

**(1) Enter Engineering setting mode 2.**

In the RUN mode, press ,  and **MODE** keys (in that order) together for approx. 3 seconds. The unit will enter Engineering setting mode 2.

Characters, Factory Default	Setting Item, Function, Setting Range
	<b>Input type</b> • Selects an input type from thermocouple (10 types), RTD (2 types), direct current (2 types) and DC voltage (4 type), and the unit °C/°F. • <b>When changing the input from DC voltage to other inputs, remove the sensor connected to this controller first, then change the input. If the input is changed with the sensor connected, the input circuit may break.</b> • When changing an input type, refer to Section "9.6 Items to be Initialized by Changing Settings" (p.104). • Selection item:
	K      -200 to 1370 °C
	K      -200.0 to 400.0 °C

Characters, Factory Default	Setting Item, Function, Setting Range	
J00C	J	-200 to 1000 °C
r00C	R	0 to 1760 °C
S00C	S	0 to 1760 °C
b00C	B	0 to 1820 °C
E00C	E	-200 to 800 °C
T00C	T	-200.0 to 400.0 °C
N00C	N	-200 to 1300 °C
PL2C	PL-II	0 to 1390 °C
C00C	C(W/Re5-26)	0 to 2315 °C
Pt1C	Pt100	-200.0 to 850.0 °C
JPt1C	JPt100	-200.0 to 500.0 °C
Pt0C	Pt100	-200 to 850 °C
JPt0C	JPt100	-200 to 500 °C
K00F	K	-328 to 2498 °F
K00F	K	-328.0 to 752.0 °F
J00F	J	328 to 1832 °F
r00F	R	32 to 3200 °F
S00F	S	32 to 3200 °F
b00F	B	32 to 3308 °F
E00F	E	-328 to 1472 °F
T00F	T	-328.0 to 752.0 °F
N00F	N	-328 to 2372 °F
PL2F	PL-II	32 to 2534 °F
C00F	C(W/Re5-26)	32 to 4199 °F
Pt1F	Pt100	-328.0 to 1562.0 °F
JPt1F	JPt100	-328.0 to 932.0 °F
Pt0F	Pt100	-328 to 1562 °F
JPt0F	JPt100	-328 to 932 °F
420A	4 to 20 mA	-2000 to 10000
020A	0 to 20 mA	-2000 to 10000
001V	0 to 1 V	-2000 to 10000
005V	0 to 5 V	-2000 to 10000
105V	1 to 5 V	-2000 to 10000
010V	0 to 10 V	-2000 to 10000
SFLH 0 1370	<b>Scaling high limit</b> <ul style="list-style-type: none"> <li>• Sets scaling high limit value.</li> <li>• Setting range: Scaling low limit to Input range high limit DC voltage, current inputs: -2000 to 10000 (The placement of the decimal point follows the selection.)</li> </ul>	
SFLL 0 -200	<b>Scaling low limit</b> <ul style="list-style-type: none"> <li>• Sets scaling low limit value.</li> <li>• Setting range: Input range low limit to Scaling high limit DC voltage, current inputs: -2000 to 10000 (The placement of the decimal point follows the selection.)</li> </ul>	

Characters, Factory Default	Setting Item, Function, Setting Range	
	<b>Decimal point place</b> <ul style="list-style-type: none"> <li>• Selects decimal point place.</li> <li>• Selection item:</li> </ul>	
	0000	No decimal point
	0000	1 digit after decimal point
	0000	2 digits after decimal point
	0000	3 digits after decimal point
Available only when DC voltage or current input is selected in [Input type].		
	<b>Event output EV1 allocation</b> <ul style="list-style-type: none"> <li>• Selects Event output EV1 from the table below.</li> <li>• If Event output EV1 is changed, some setting items will be initialized. Refer to Section “9.6 Items to be Initialized by Changing Settings” (p.104).</li> <li>• Selection item:</li> </ul>	
	0000	No event
	0001	Alarm output, High limit alarm
	0002	Alarm output, Low limit alarm
	0003	Alarm output, High/Low limits alarm
	0004	Alarm output, High/Low limits independent alarm
	0005	Alarm output, High/Low limit range alarm
	0006	Alarm output, High/Low limit range independent alarm
	0007	Alarm output, Process high alarm
	0008	Alarm output, Process low alarm
	0009	Alarm output, High limit with standby alarm
	0010	Alarm output, Low limit with standby alarm
	0011	Alarm output, High/Low limits with standby alarm
	0012	Alarm output, High/Low limits with standby independent alarm
	0013	Heater burnout alarm output (when C5W, EIW or W option is ordered): Detects load current value with CT (current transformer), and turns ON if it is lower than heater burnout alarm value.
	0014	Loop break alarm output: Sets Loop break alarm time and span. If the PV does not reach the Loop break alarm span setting within the time allotted to assess the Loop break alarm (after the MV has reached 100% or the OUT high limit value), the alarm output is turned ON. If the PV does not drop to the Loop break alarm span setting within the time allotted to assess the Loop break alarm (after the MV has reached 0% or the OUT low limit value), the alarm output is turned ON.
	0015	Time signal output: Turns ON during program control RUN, by setting Time signal output OFF time and ON time within total time in one pattern.
0016	Output during AT: Turns ON during AT.	
0017	Pattern end output: Turns ON after Program control ends, and remains ON during the time set in [Pattern end output time].	

Characters, Factory Default	Setting Item, Function, Setting Range
00 18	Output by communication command: Communication command 8004H B0 EV1 output 0: OFF, 1: ON B1 EV2 output 0: OFF, 1: ON B2 EV3 output 0: OFF, 1: ON
00 19	RUN output: Turns ON during program control RUN.
	When 00 1 (High limit alarm) to 00 12 (High/Low limits with standby independent alarm) or 00 15 (Time signal output) is selected, one alarm can be set to one event output. When 00 13 (Heater burnout alarm output), 00 14 (Loop break alarm output) or 00 16 (Output during AT) to 00 19 (RUN output) are selected, each output is common to multiple event outputs.

• About alarm output

EV1 alarm output actions are shown below.

• High limit alarm

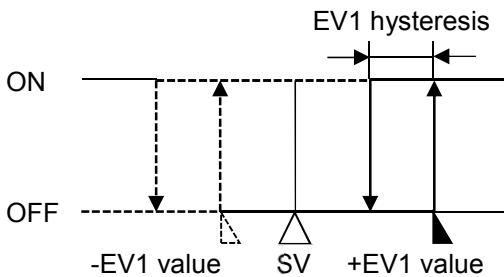

(Fig. 6-1)

• Low limit alarm

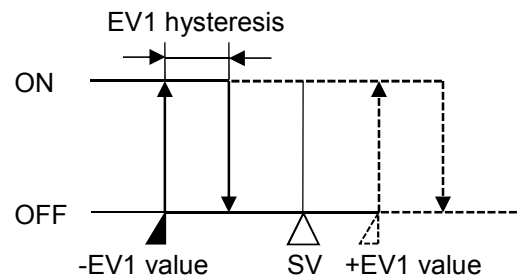

(Fig. 6-2)

• High/Low limits alarm

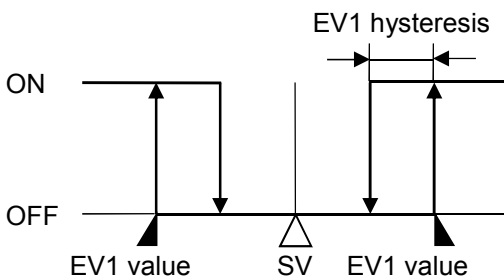

(Fig. 6-3)

• High/Low limits independent alarm

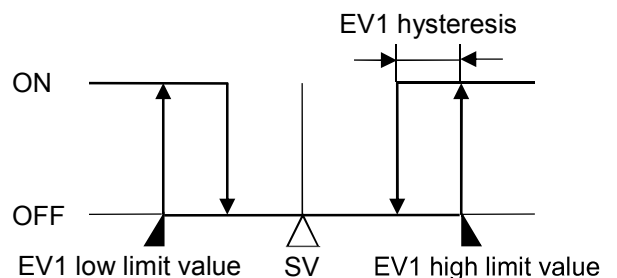

(Fig. 6-4)

• High/Low limit range alarm

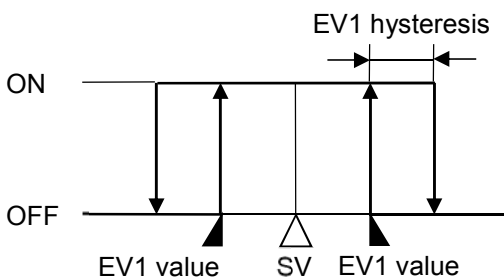

(Fig. 6-5)

• High/Low limit range independent alarm

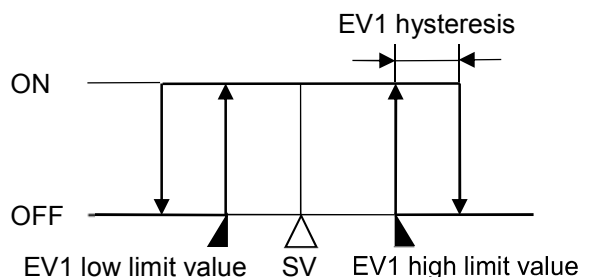

(Fig. 6-6)



- **Process high alarm**

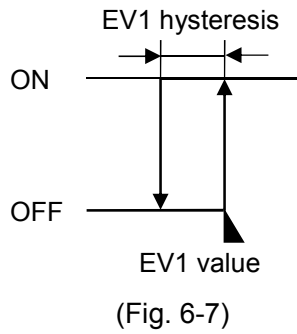

- **Process low alarm**

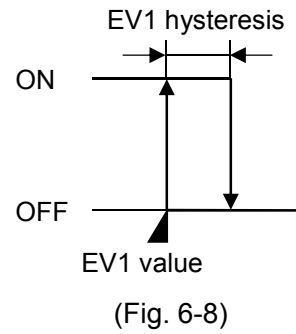

- **High limit with standby alarm**

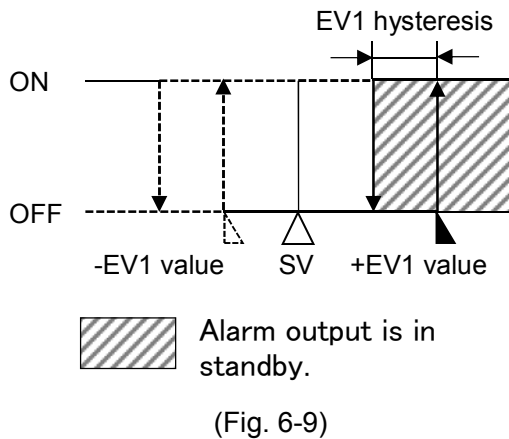

- **Low limit with standby alarm**

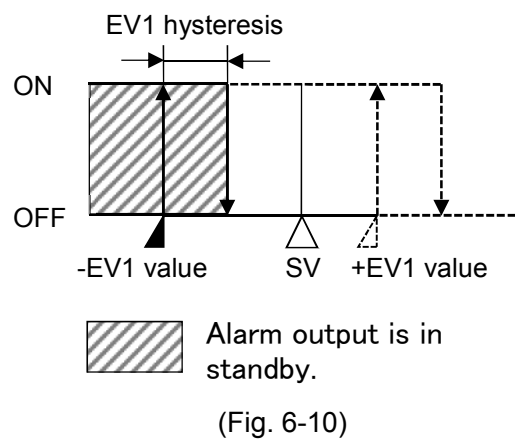

- **High/Low limits with standby alarm**

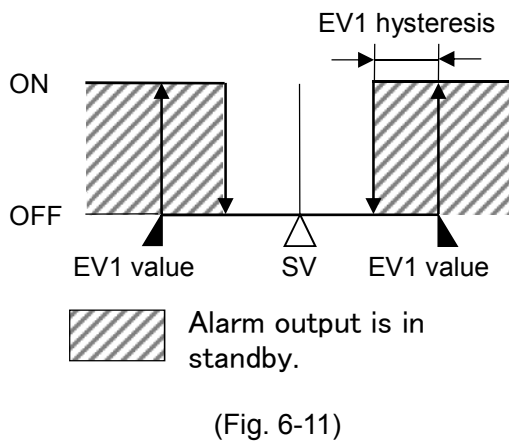

- **High/Low limits with standby independent alarm**

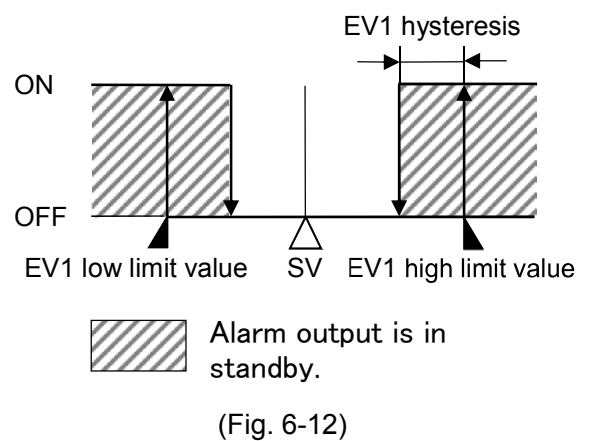

- **About Time signal output**

Time signal output OFF time and Time signal output ON time are set within total time in one pattern. After program control starts, Time signal output turns ON during Time signal output ON time after Time signal output OFF time has elapsed.

During Wait action or program control Hold, progress time of Time signal output stops.

When step time is changed during program control RUN, Time signal output timing is re-calculated using the changed pattern time.

### Example of program pattern setting

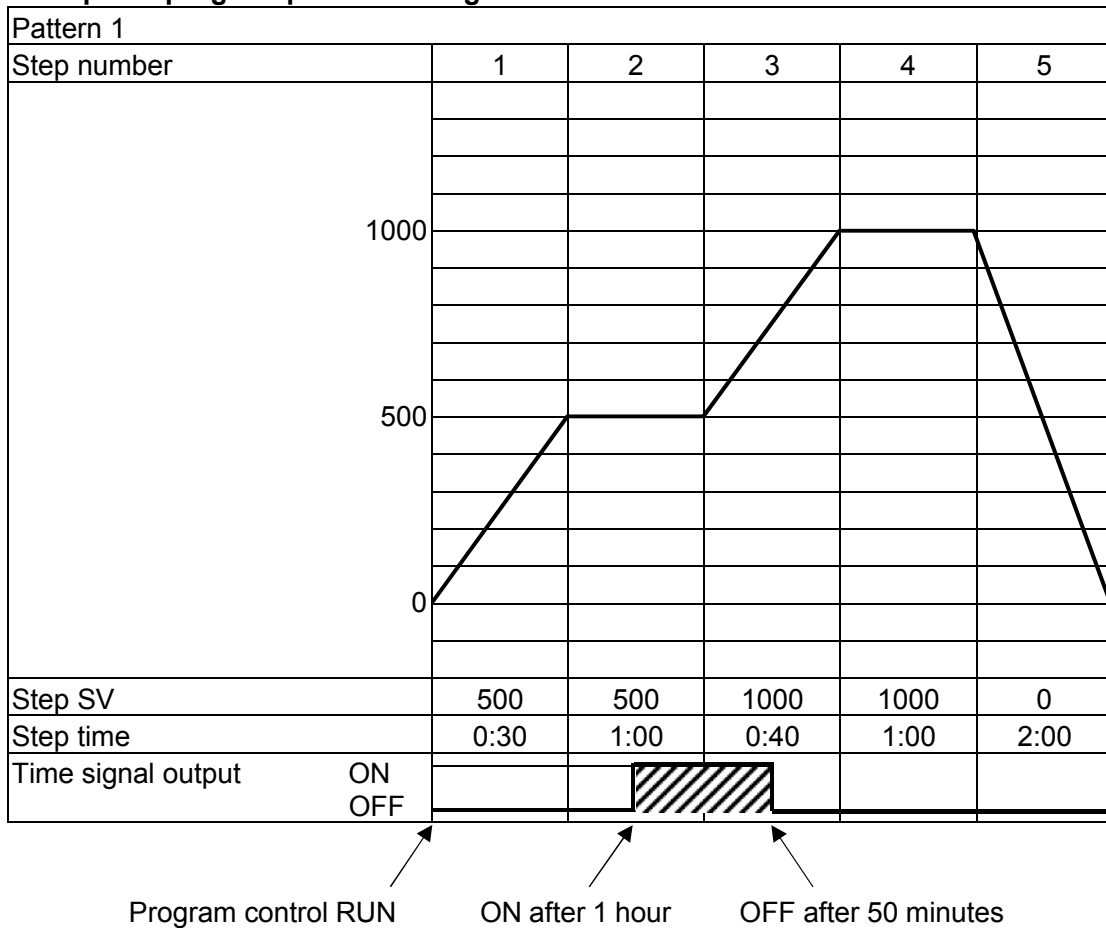

(e.g.) Time signal output setting

Time signal output OFF time: 1 hour

Time signal output ON time: 50 minutes

(Fig. 6-13)

### Explanation of Time signal output

In the above program pattern example, Time signal output turns ON one hour after program control RUN starts (30 minutes after the unit entered Step 2). Time signal output turns OFF 50 minutes after Time signal output turned ON (20 minutes after the unit entered Step 3).



Characters, Factory Default	Setting Item, Function, Setting Range
Press the <span style="border: 1px solid black; padding: 2px;">MODE</span> key multiple times until the following characters appear.	
	<b>Step time unit</b> • Selects the Step time unit. • Selection item:
	Hours : Minutes
	Minutes : Seconds

Characters, Factory Default	Setting Item, Function, Setting Range
<b>P-ET</b> 0 STOP	<b>Power restore action</b> • If the power fails during program control RUN, the controller can be operated depending on the selection in [Power restore action]. • Selection item:
	<b>STOP</b> <b>Stops after power is restored:</b> After power is restored, stops current program control, and returns to the Program control STOP (in Standby).
	<b>CONF</b> <b>Continues after power is restored:</b> After power is restored, continues (resumes) previous program control.
	<b>Hold</b> <b>Suspends after power is restored</b> After power is restored, suspends (on hold) current program control, and performs Fixed value control using the SV from the point of suspension. Pressing the <b>RUN</b> key cancels suspension, and Program control resumes.
<b>S-SV</b> 0 0000	<b>Step SV when program control starts</b> • Sets step SV when program control starts. • Setting range: Scaling low limit to Scaling high limit (The placement of the decimal point follows the selection.)
<b>S-SL</b> 0 P800	<b>Program control start type</b> • Program control start type can be selected. • Selection item:
	<b>P800</b> <b>PV start</b> Only when program control starts, the step SV and step time are advanced to the PV, then program control starts.
	<b>P8-0</b> <b>PVR start</b> When program control starts and in pattern repeating, the step SV and step time are advanced to the PV, then program control starts.
	<b>S800</b> <b>SV start</b> Program control starts from the value set in [Step SV when program control starts].
Press the <b>RST</b> key. The unit returns to RUN mode.	

## (2) Control parameter setting mode.

In RUN mode, press the  and **MODE** keys (in that order) together. The unit enters Control parameter setting mode.

Characters, Factory Default	Setting Item, Function, Setting Range
<b>AT 00</b> 0 ----	<b>AT Perform/Cancel</b> Do not perform AT during initial settings.

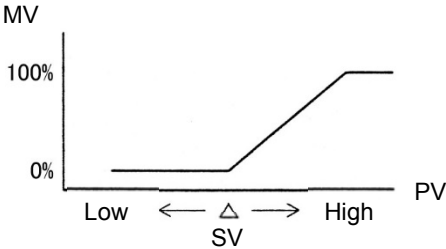
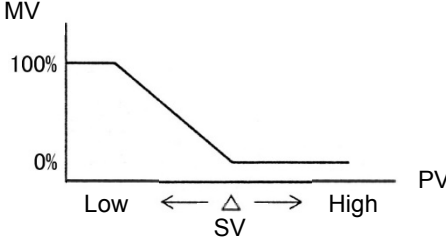
Characters, Factory Default	Setting Item, Function, Setting Range				
Press the <b>MODE</b> key multiple times until the following characters appear.					
	<p><b>OUT1 proportional cycle</b></p> <ul style="list-style-type: none"> <li>• Sets OUT1 proportional cycle.</li> <li>• For the relay contact output type, if the proportional cycle time is decreased, the frequency of the relay action increases, and the life of the relay contact is shortened.</li> </ul> <p>Factory default value differs depending on the output type as follows:</p> <ul style="list-style-type: none"> <li>Relay contact output type: 30 seconds</li> <li>Non-contact voltage output type: 3 seconds</li> <li>Direct current output type: Not available</li> </ul> <ul style="list-style-type: none"> <li>• Setting range: 0.5, 1 to 120 seconds</li> </ul> <p>Available when OUT1 is relay contact output or non-contact voltage output.</p>				
Press the <b>MODE</b> key multiple times until the following characters appear.					
	<p><b>Direct/Reverse action</b></p> <ul style="list-style-type: none"> <li>• Selects either Direct (Cooling) or Reverse (Heating) control action.</li> </ul> <p><b>Direct action</b></p> <p>In Direct action, MV is increased when PV is higher than SV (positive deviation). Refrigerators perform Direct action.</p>  <p>(Fig. 6-14)</p> <p><b>Reverse action</b></p> <p>In Reverse action, MV is increased when SV is higher than PV (negative deviation). Electric furnaces perform Reverse action.</p>  <p>(Fig. 6-15)</p> <ul style="list-style-type: none"> <li>• Selection item:</li> </ul> <table border="1" data-bbox="453 1877 1481 1960"> <tr> <td><b>HEAT</b></td> <td>Reverse action</td> </tr> <tr> <td><b>COOL</b></td> <td>Direct action</td> </tr> </table>	<b>HEAT</b>	Reverse action	<b>COOL</b>	Direct action
<b>HEAT</b>	Reverse action				
<b>COOL</b>	Direct action				
Press the <b>RST</b> key. The unit returns to RUN mode.					

At this stage, the initial settings are complete.

Refer to Sections '7. Basic Settings and Operation (p.37)' and '8. Explanation of Setting Items (p.43)'.

# 7. Basic Settings and Operation

## 7.1 Procedure of Basic Settings and Operation

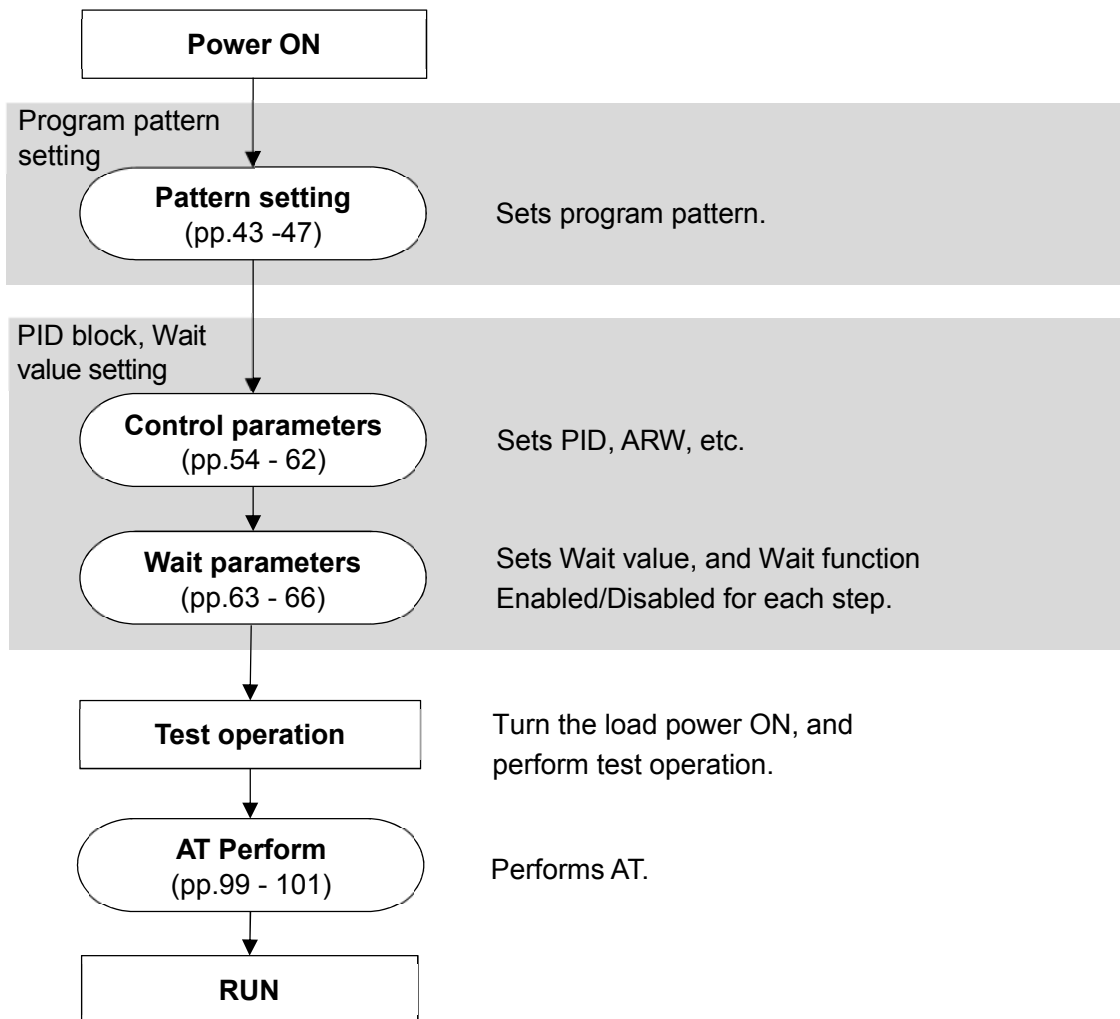

(Fig. 7.1-1)

## 7.2 Program Pattern Setting

### • Example of Program Pattern Setting

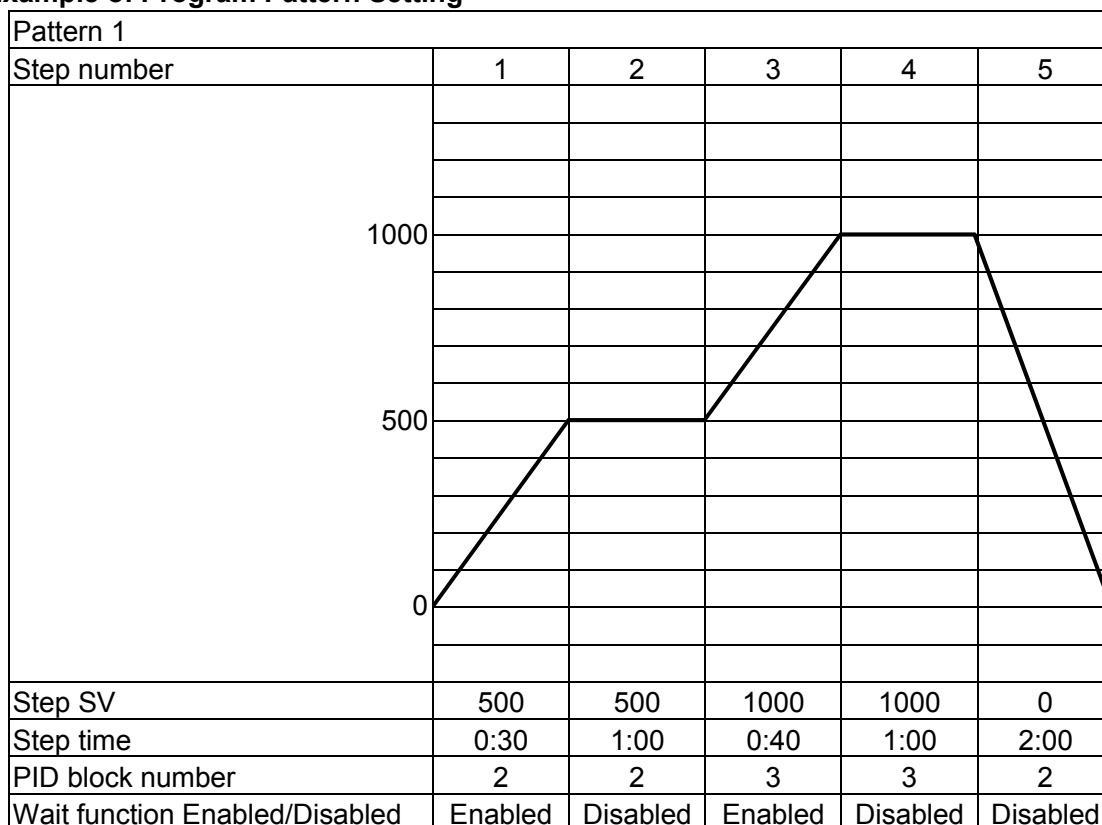

(Fig. 7.2-1)

### Explanation of Program Pattern

Step 1: After program control starts, control is performed so that SV gradually rises from 0°C to 500°C for 30 minutes.

Step 2: Control is performed to keep the SV at 500°C for 1 hour.

Step 3: Control is performed so that SV gradually rises from 500°C to 1000°C for 40 minutes.

Step 4: Control is performed to keep the SV at 1000°C for 1 hour.

Step 5: Control is performed so that SV gradually falls from 1000°C to 0°C for 2 hours.

### • Example of PID Block Setting

If program pattern is not set for a step, its PID block number becomes 1 (factory default).

We highly recommend that you leave the factory defaults of PID block 1 as they are, and set the values from Block 2.

Control parameters such as PID, ARW are common to all patterns.

Block number	OUT1 proportional band	Integral time	Derivative time	ARW	OUT2 proportional band
1	10°C	200 sec	50 sec	50%	10°C
2	10°C (*)	200 sec (*)	50 sec (*)	50% (*)	10°C (*)
3	10°C (*)	200 sec (*)	50 sec (*)	50% (*)	10°C (*)

(\*) Setting items in PID block are determined after performing AT. So they are currently factory default values.

### • Example of Wait Value Setting

Wait value: 10°C

Wait value is common to all steps of each pattern.

The operation method is described below, based on the program pattern, PID block and wait value settings.

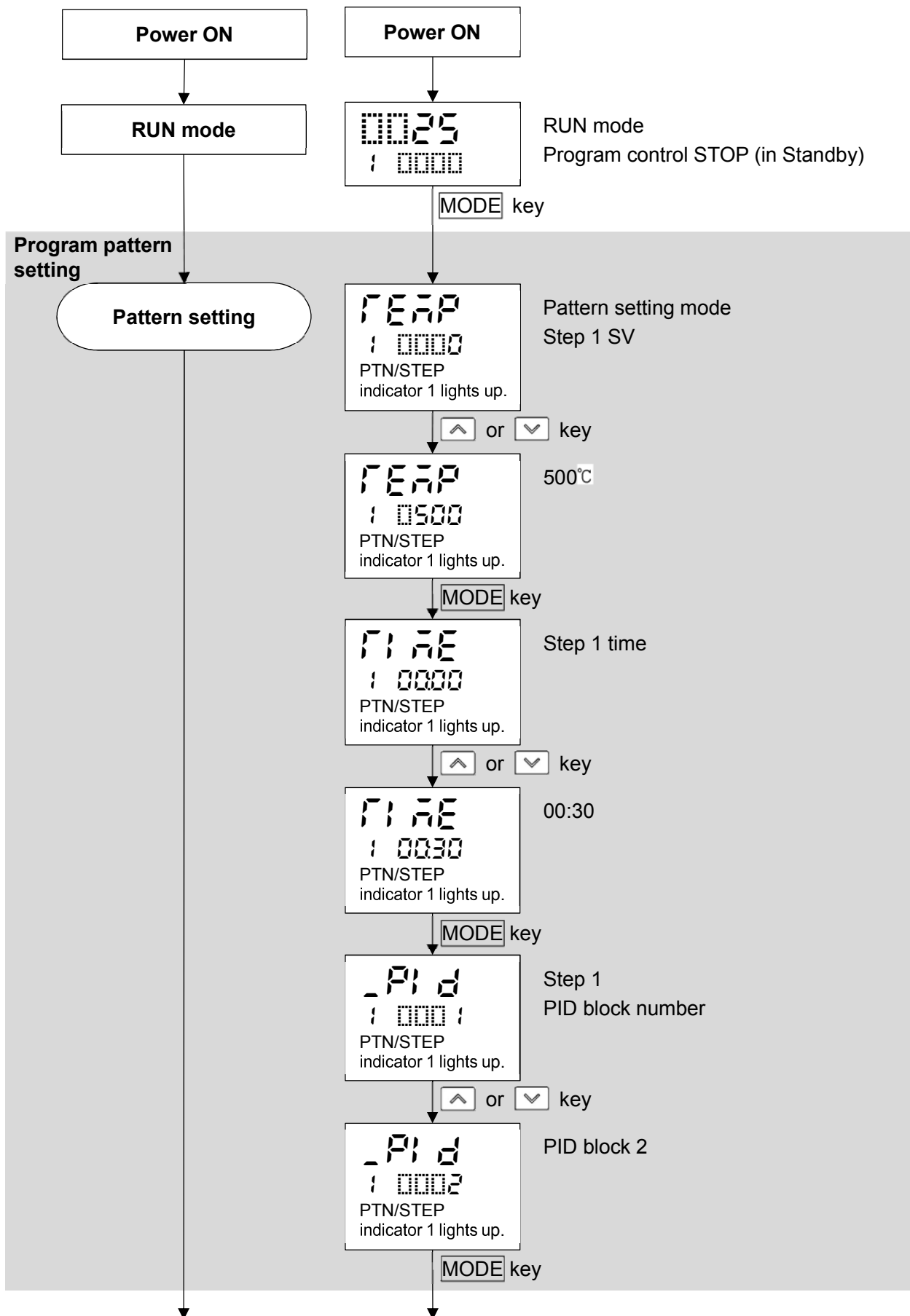

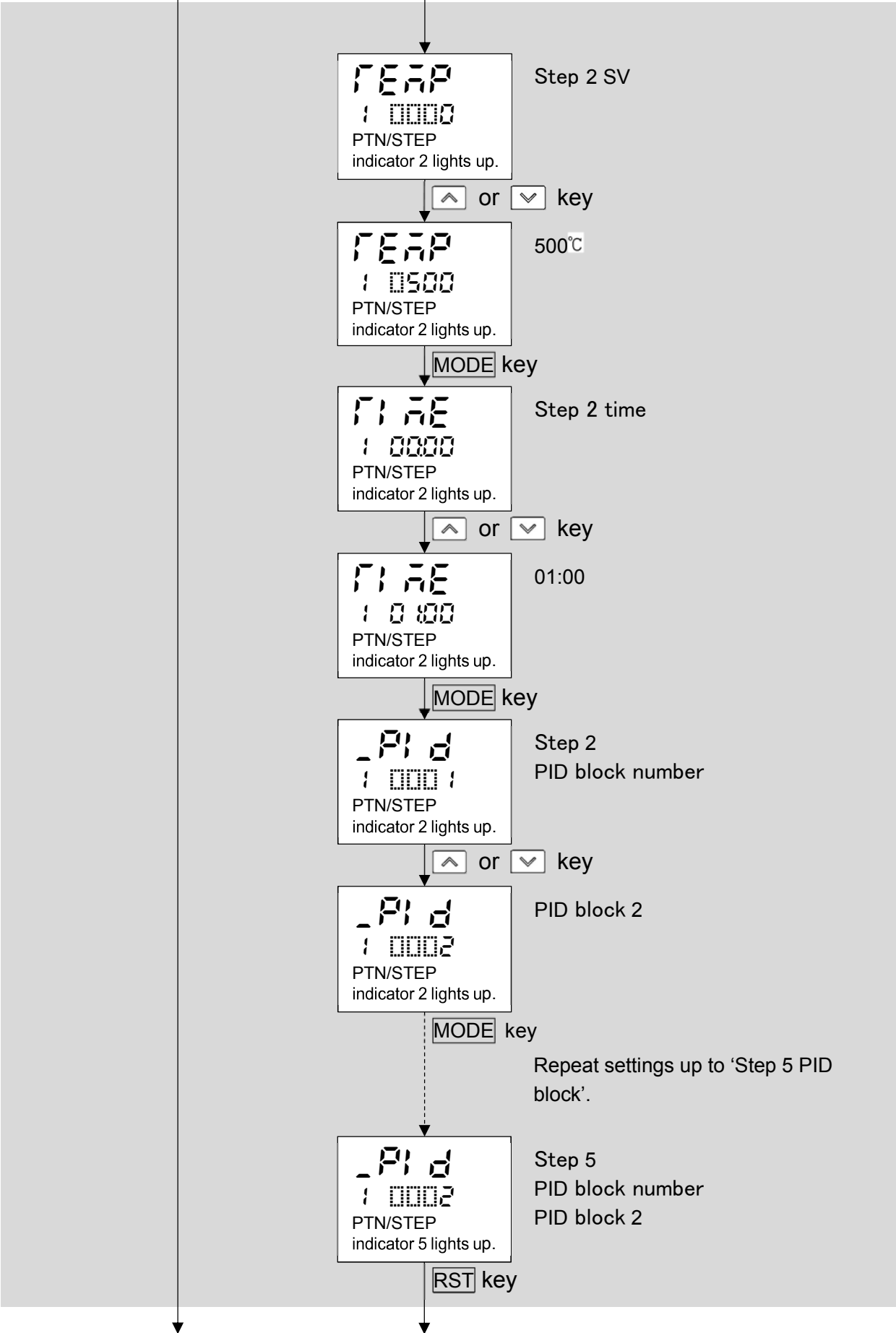



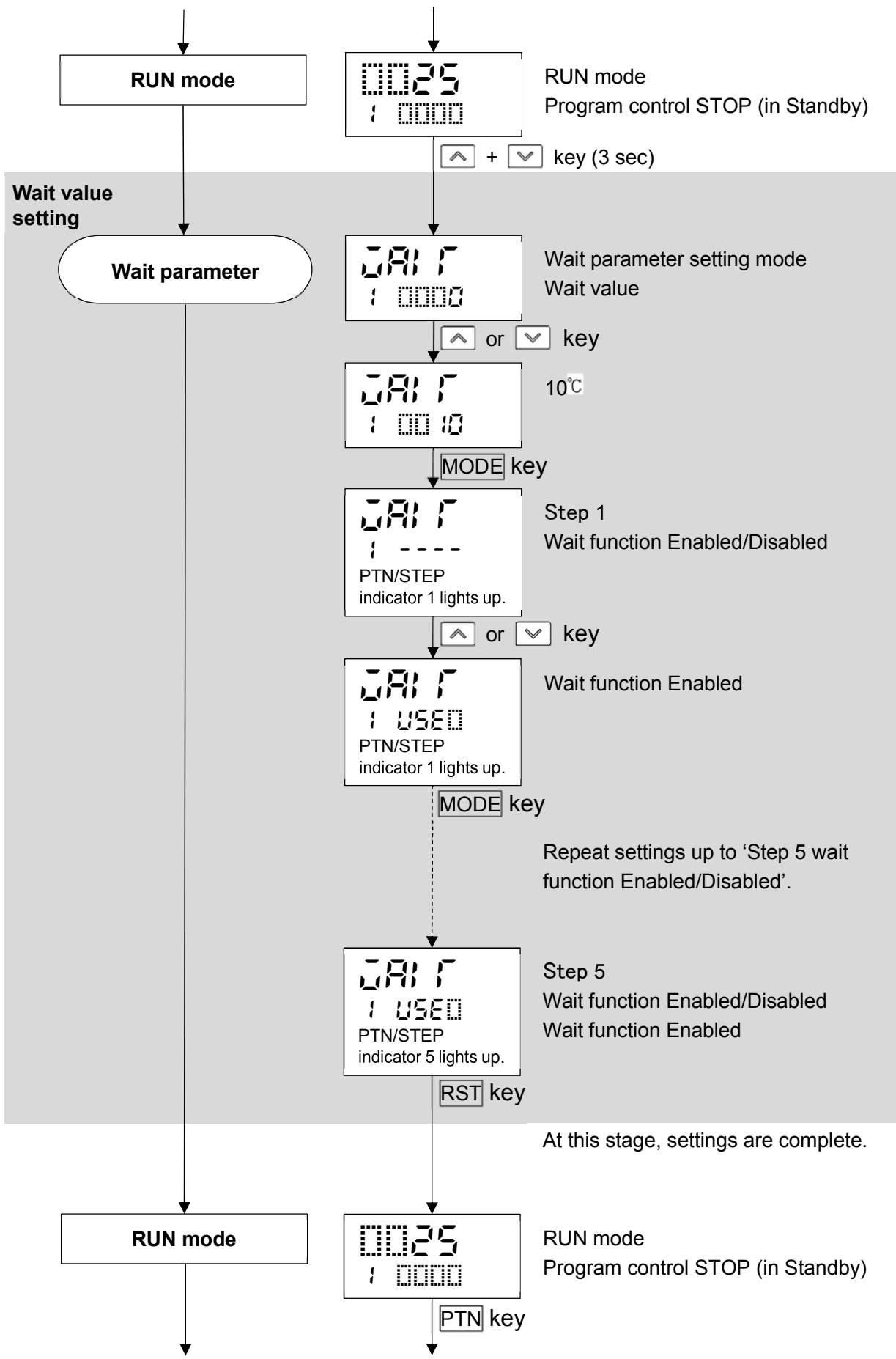

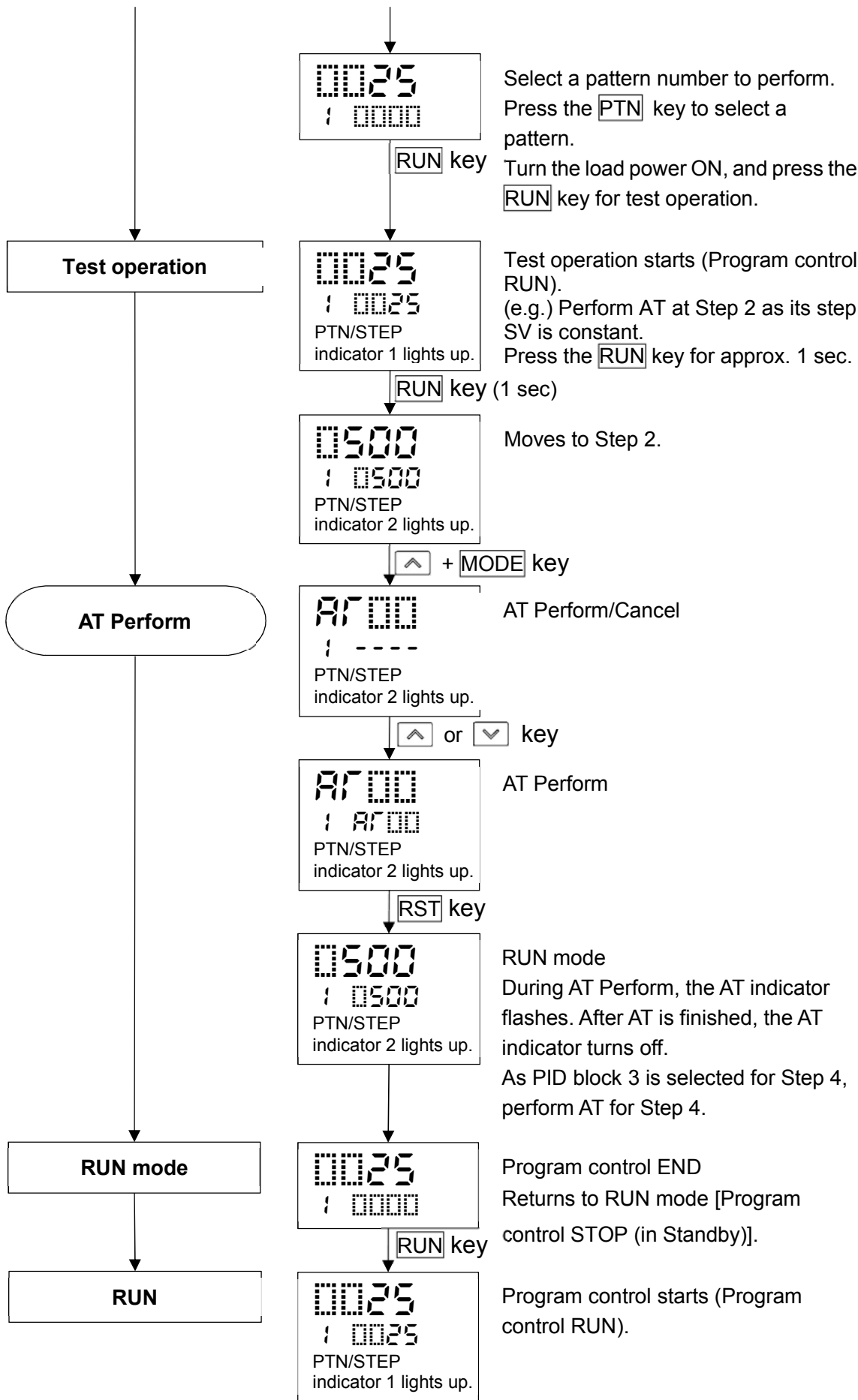

# 8. Explanation of Setting Items

Setting items for the following mode will be described:

Pattern setting mode, Event setting mode, Control parameter setting mode, Wait parameter setting mode, Engineering setting mode 1, Engineering setting mode 2.

## 8.1 Setting Items in Pattern Setting Mode

In Pattern setting mode, the following items are set:

Step SV, Step time, PID block number, Number of repetitions, pattern link

Settings are performed for the pattern selected when entering Pattern setting mode.

During program control RUN, settings are possible only for the currently performing pattern.

If 'Pattern link Enabled' is selected in [Pattern link]: Even if the performing pattern is changed from 1 to 2 during pattern setting mode, Pattern 1 will be remained, and the pattern number will not be updated until the unit reverts to the RUN mode.

### • Before entering Pattern setting mode







Select a pattern number with the  key before entering Pattern setting mode.







### • To enter Pattern setting mode





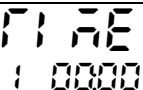

In RUN mode, press the  key. The unit enters Pattern setting mode.

Pattern 1 is used for the explanation of setting items in Pattern setting mode.

Characters, Factory Default	Setting Item, Function, Setting Range
<p>PTN/STEP indicator 1 lights up.</p>	<p><b>Step 1 SV</b></p> <ul style="list-style-type: none"> <li>Sets Step 1 SV.</li> <li>Step SV is a value (SV) at the end of the step.</li> <li>Setting range: Scaling low limit to Scaling high limit</li> </ul>
<p>PTN/STEP indicator 1 lights up.</p>	<p><b>Step 1 time</b></p> <ul style="list-style-type: none"> <li>Sets Step 1 time.</li> <li>Step time is the processing time of the step.</li> <li>Setting range: - - - -, 00:00 to 99.59 (Time unit follows the selection in [Step time unit].) If the <input type="checkbox"/> key is pressed at 00:00, - - - - will appear. If - - - - is set, Fixed value control will be performed using Step 1 SV.</li> </ul>
<p>PTN/STEP indicator 1 lights up.</p>	<p><b>Step 1 PID block number</b></p> <ul style="list-style-type: none"> <li>Selects PID block number used for Step 1.</li> <li>Selection item: 1 to 10</li> </ul>
<p>PTN/STEP indicator 2 lights up.</p>	<p><b>Step 2 SV</b></p> <ul style="list-style-type: none"> <li>Sets Step 2 SV.</li> <li>Step SV is a value (SV) at the end of the step.</li> <li>Setting range: Scaling low limit to Scaling high limit</li> </ul>

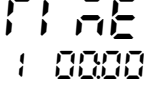
Characters, Factory Default	Setting Item, Function, Setting Range
 <p>PTN/STEP indicator 2 lights up.</p>	<p><b>Step 2 time</b></p> <ul style="list-style-type: none"> <li>• Sets Step 2 time.</li> </ul> <p>Step time is the processing time of the step.</p> <ul style="list-style-type: none"> <li>• Setting range:            - - - - , 00:00 to 99.59 (Time unit follows the selection in [Step time unit].)            If the <input type="checkbox"/> key is pressed at 00:00, - - - - will appear.            If - - - - is set, Fixed value control will be performed using Step 2 SV.</li> </ul>
 <p>PTN/STEP indicator 2 lights up.</p>	<p><b>Step 2 PID block number</b></p> <ul style="list-style-type: none"> <li>• Selects PID block number used for Step 2.</li> <li>• Selection item: 1 to 10</li> </ul>
 <p>PTN/STEP indicator 3 lights up.</p>	<p><b>Step 3 SV</b></p> <ul style="list-style-type: none"> <li>• Sets Step 3 SV.</li> </ul> <p>Step SV is a value (SV) at the end of the step.</p> <ul style="list-style-type: none"> <li>• Setting range: Scaling low limit to Scaling high limit</li> </ul>
 <p>PTN/STEP indicator 3 lights up.</p>	<p><b>Step 3 time</b></p> <ul style="list-style-type: none"> <li>• Sets Step 3 time.</li> </ul> <p>Step time is the processing time of the step.</p> <ul style="list-style-type: none"> <li>• Setting range:            - - - - , 00:00 to 99.59 (Time unit follows the selection in [Step time unit].)            If the <input type="checkbox"/> key is pressed at 00:00, - - - - will appear.            If - - - - is set, Fixed value control will be performed using Step 3 SV.</li> </ul>
 <p>PTN/STEP indicator 3 lights up.</p>	<p><b>Step 3 PID block number</b></p> <ul style="list-style-type: none"> <li>• Selects PID block number used for Step 3.</li> <li>• Selection item: 1 to 10</li> </ul>
 <p>PTN/STEP indicator 4 lights up.</p>	<p><b>Step 4 SV</b></p> <ul style="list-style-type: none"> <li>• Sets Step 4 SV.</li> </ul> <p>Step SV is a value (SV) at the end of the step.</p> <ul style="list-style-type: none"> <li>• Setting range: Scaling low limit to Scaling high limit</li> </ul>
 <p>PTN/STEP indicator 4 lights up.</p>	<p><b>Step 4 time</b></p> <ul style="list-style-type: none"> <li>• Sets Step 4 time.</li> </ul> <p>Step time is the processing time of the step.</p> <ul style="list-style-type: none"> <li>• Setting range:            - - - - , 00:00 to 99.59 (Time unit follows the selection in [Step time unit].)            If the <input type="checkbox"/> key is pressed at 00:00, - - - - will appear.            If - - - - is set, Fixed value control will be performed using Step 4 SV.</li> </ul>

Characters, Factory Default	Setting Item, Function, Setting Range
 PTN/STEP indicator 4 lights up.	<b>Step 4 PID block number</b> <ul style="list-style-type: none"> <li>• Selects PID block number used for Step 4.</li> <li>• Selection item: 1 to 10</li> </ul>
 PTN/STEP indicator 5 lights up.	<b>Step 5 SV</b> <ul style="list-style-type: none"> <li>• Sets Step 5 SV.</li> <li>• Step SV is a value (SV) at the end of the step.</li> <li>• Setting range: Scaling low limit to Scaling high limit</li> </ul>
 PTN/STEP indicator 5 lights up.	<b>Step 5 time</b> <ul style="list-style-type: none"> <li>• Sets Step 5 time.</li> <li>• Step time is the processing time of the step.</li> <li>• Setting range: ----, 00:00 to 99.59 (Time unit follows the selection in [Step time unit].) If the <input type="checkbox"/> key is pressed at 00:00, ---- will appear. If ---- is set, Fixed value control will be performed using Step 5 SV.</li> </ul>
 PTN/STEP indicator 5 lights up.	<b>Step 5 PID block number</b> <ul style="list-style-type: none"> <li>• Selects PID block number used for Step 5.</li> <li>• Selection item: 1 to 10</li> </ul>
 PTN/STEP indicator 6 lights up.	<b>Step 6 SV</b> <ul style="list-style-type: none"> <li>• Sets Step 6 SV.</li> <li>• Step SV is a value (SV) at the end of the step.</li> <li>• Setting range: Scaling low limit to Scaling high limit</li> </ul>
 PTN/STEP indicator 6 lights up.	<b>Step 6 time</b> <ul style="list-style-type: none"> <li>• Sets Step 6 time.</li> <li>• Step time is the processing time of the step.</li> <li>• Setting range: ----, 00:00 to 99.59 (Time unit follows the selection in [Step time unit].) If the <input type="checkbox"/> key is pressed at 00:00, ---- will appear. If ---- is set, Fixed value control will be performed using Step 6 SV.</li> </ul>
 PTN/STEP indicator 6 lights up.	<b>Step 6 PID block number</b> <ul style="list-style-type: none"> <li>• Selects PID block number used for Step 6.</li> <li>• Selection item: 1 to 10</li> </ul>
 PTN/STEP indicator 7 lights up.	<b>Step 7 SV</b> <ul style="list-style-type: none"> <li>• Sets Step 7 SV.</li> <li>• Step SV is a value (SV) at the end of the step.</li> <li>• Setting range: Scaling low limit to Scaling high limit</li> </ul>

Characters, Factory Default	Setting Item, Function, Setting Range
 PTN/STEP indicator 7 lights up.	<b>Step 7 time</b> <ul style="list-style-type: none"> <li>Sets Step 7 time.</li> </ul> Step time is the processing time of the step. <ul style="list-style-type: none"> <li>Setting range:               <ul style="list-style-type: none"> <li>----, 00:00 to 99.59 (Time unit follows the selection in [Step time unit].)</li> </ul> </li> </ul> If the <input type="checkbox"/> key is pressed at 00:00, ---- will appear. If ---- is set, Fixed value control will be performed using Step 7 SV.
 PTN/STEP indicator 7 lights up.	<b>Step 7 PID block number</b> <ul style="list-style-type: none"> <li>Selects PID block number used for Step 7.</li> <li>Selection item:               <ul style="list-style-type: none"> <li>1 to 10</li> </ul> </li> </ul>
 PTN/STEP indicator 8 lights up.	<b>Step 8 SV</b> <ul style="list-style-type: none"> <li>Sets Step 8 SV.</li> </ul> Step SV is a value (SV) at the end of the step. <ul style="list-style-type: none"> <li>Setting range:               <ul style="list-style-type: none"> <li>Scaling low limit to Scaling high limit</li> </ul> </li> </ul>
 PTN/STEP indicator 8 lights up.	<b>Step 8 time</b> <ul style="list-style-type: none"> <li>Sets Step 8 time.</li> </ul> Step time is the processing time of the step. <ul style="list-style-type: none"> <li>Setting range:               <ul style="list-style-type: none"> <li>----, 00:00 to 99.59 (Time unit follows the selection in [Step time unit].)</li> </ul> </li> </ul> If the <input type="checkbox"/> key is pressed at 00:00, ---- will appear. If ---- is set, Fixed value control will be performed using Step 8 SV.
 PTN/STEP indicator 8 lights up.	<b>Step 8 PID block number</b> <ul style="list-style-type: none"> <li>Selects PID block number used for Step 8.</li> <li>Selection item:               <ul style="list-style-type: none"> <li>1 to 10</li> </ul> </li> </ul>
 PTN/STEP indicator 9 lights up.	<b>Step 9 SV</b> <ul style="list-style-type: none"> <li>Sets Step 9 SV.</li> </ul> Step SV is a value (SV) at the end of the step. <ul style="list-style-type: none"> <li>Setting range:               <ul style="list-style-type: none"> <li>Scaling low limit to Scaling high limit</li> </ul> </li> </ul>
 PTN/STEP indicator 9 lights up.	<b>Step 9 time</b> <ul style="list-style-type: none"> <li>Sets Step 9 time.</li> </ul> Step time is the processing time of the step. <ul style="list-style-type: none"> <li>Setting range:               <ul style="list-style-type: none"> <li>----, 00:00 to 99.59 (Time unit follows the selection in [Step time unit].)</li> </ul> </li> </ul> If the <input type="checkbox"/> key is pressed at 00:00, ---- will appear. If ---- is set, Fixed value control will be performed using Step 9 SV.

Characters, Factory Default	Setting Item, Function, Setting Range				
 PTN/STEP indicator 9 lights up.	<b>Step 9 PID block number</b> <ul style="list-style-type: none"> <li>• Selects PID block number used for Step 9.</li> <li>• Selection item: 1 to 10</li> </ul>				
 PTN/STEP indicator 10 lights up.	<b>Step 10 SV</b> <ul style="list-style-type: none"> <li>• Sets Step 10 SV.</li> <li>• Step SV is a value (SV) at the end of the step.</li> <li>• Setting range: Scaling low limit to Scaling high limit</li> </ul>				
 PTN/STEP indicator 10 lights up.	<b>Step 10 time</b> <ul style="list-style-type: none"> <li>• Sets Step 10 time.</li> <li>• Step time is the processing time of the step.</li> <li>• Setting range: - - - -, 00:00 to 99.59 (Time unit follows the selection in [Step time unit].)</li> <li>• If the <input type="checkbox"/> key is pressed at 00:00, - - - - will appear.</li> <li>• If - - - - is set, Fixed value control will be performed using Step 10 SV.</li> </ul>				
 PTN/STEP indicator 10 lights up.	<b>Step 10 PID block number</b> <ul style="list-style-type: none"> <li>• Selects PID block number used for Step 10.</li> <li>• Selection item: 1 to 10</li> </ul>				
 PTN/STEP indicator turns off.	<b>Number of repetitions</b> <ul style="list-style-type: none"> <li>• Sets the number of repetitions for the selected Pattern 1</li> <li>• Setting range: 0 to 10000</li> </ul>				
 PTN/STEP indicator turns off.	<b>Pattern link</b> <ul style="list-style-type: none"> <li>• Selects whether to link Pattern 2 to currently selected pattern 1.</li> <li>• If Pattern 10 is selected, Pattern 1 can be linked, and selects whether to link Pattern 1.</li> <li>• Randomly selected pattern numbers (Pattern 1 and Pattern 5) cannot be linked.</li> <li>• For repetitions of linked pattern, the whole linked pattern will be repeated as many times as set in [Number of repetitions].</li> <li>• (e.g.) If patterns 1 and 2 are linked, and if the number of repetitions of pattern 1 is set to 2 times, the whole linked pattern (Patterns 1 and 2) will be repeated twice.</li> <li>• Selection item: <table border="1" data-bbox="459 1910 1481 1986"> <tr> <td>- - - -</td> <td>Pattern link Disabled</td> </tr> <tr> <td></td> <td>Pattern link Enabled</td> </tr> </table> </li> </ul>	- - - -	Pattern link Disabled		Pattern link Enabled
- - - -	Pattern link Disabled				
	Pattern link Enabled				

At this stage, settings for Pattern setting mode are complete.

Press the  key. The unit reverts to RUN mode.

## 8.2 Setting Items in Event Setting Mode

Setting items in Event Setting Mode differs depending on the selection in [Event output EV□ allocation]. If 001 (High limit alarm) to 012 (High/Low limits alarm with standby independent alarm) are selected in [Event output EV□ allocation], EV□ alarm value will be set.

If 015 (Time signal output) is selected in [Event output EV□ allocation], TS□ output OFF time and TS□ output ON time can be set.

Settings are performed for the pattern number selected when entering Event setting mode.

Setting values are common to all steps in each pattern.

During program control RUN, only the performing pattern can be set.

If 'Pattern link Enabled' is selected in [Pattern link]: Even if the performing pattern is changed from 1 to 2 during Event setting mode, Pattern 1 will be remained, and pattern number will not be updated until the unit reverts to the RUN mode.

### • About alarm output

EV1 alarm output actions are shown below.

EV1 alarm output will be substituted by EV2 or EV3 alarm output.

#### • High limit alarm

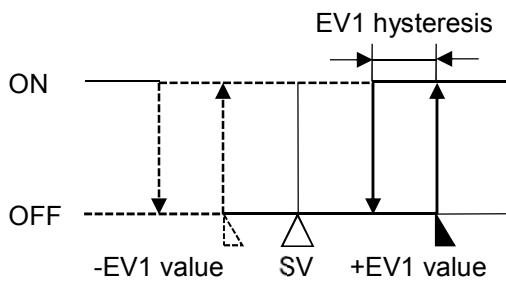

(Fig. 8.2-1)

#### • Low limit alarm

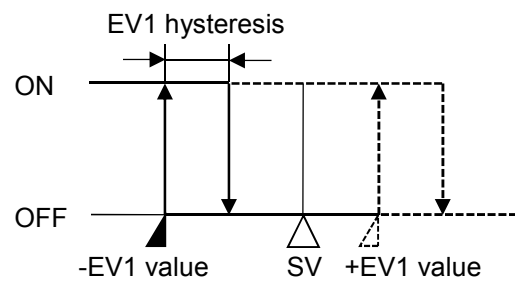

(Fig. 8.2-2)

#### • High/Low limits alarm

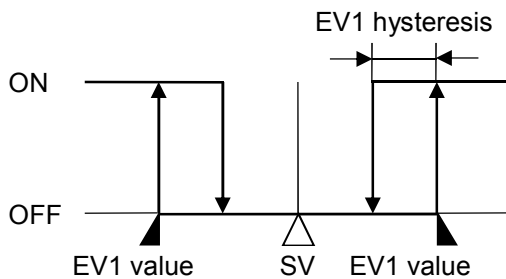

(Fig. 8.2-3)

#### • High/Low limits independent alarm

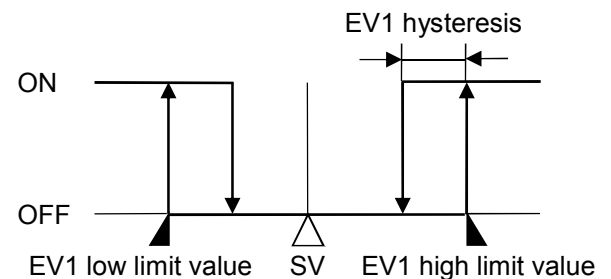

(Fig. 8.2-4)



• High/Low limit range alarm

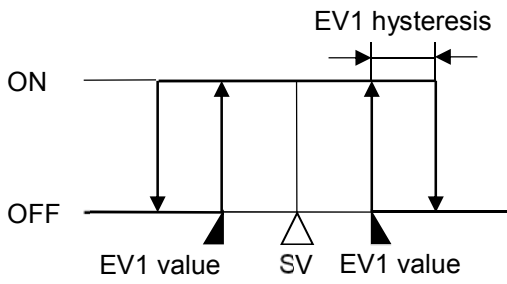

(Fig. 8.2-5)

• High/Low limit range independent alarm

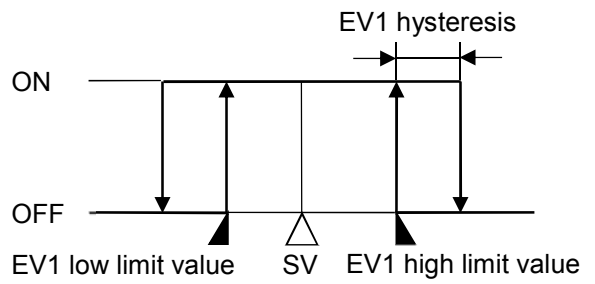

(Fig. 8.2-6)

• Process high alarm

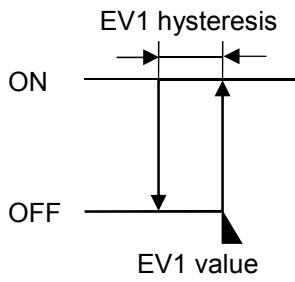

(Fig. 8.2-7)

• Process low alarm

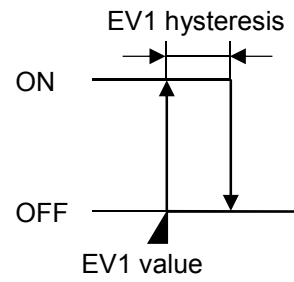

(Fig. 8.2-8)

• High limit with standby alarm

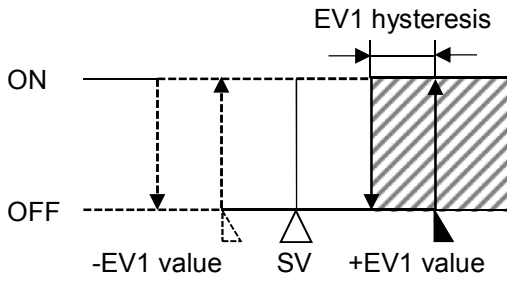

 Alarm output is in standby.

(Fig. 8.2-9)

• Low limit with standby alarm

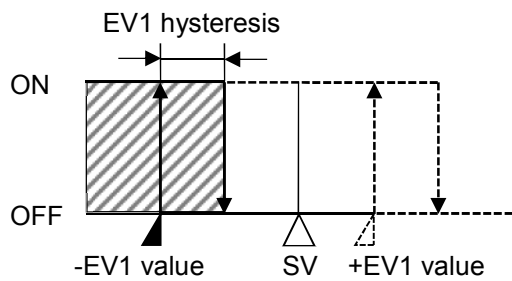

 Alarm output is in standby.

(Fig. 8.2-10)

• High/Low limits with standby alarm

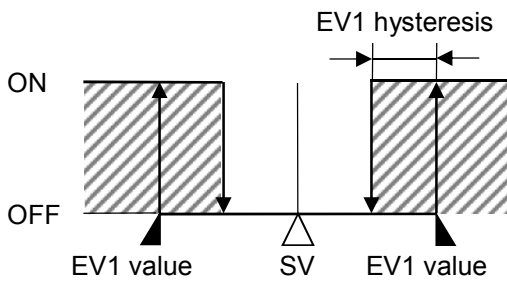

 Alarm output is in standby.

(Fig. 8.2-11)

• High/Low limits with standby independent alarm

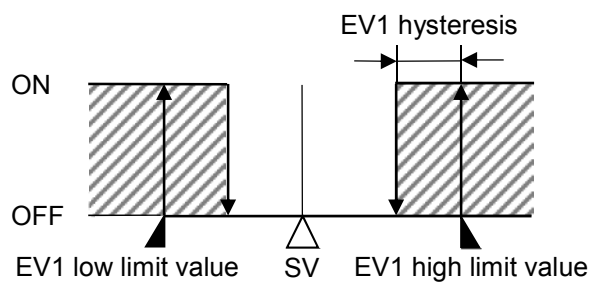

 Alarm output is in standby.

(Fig. 8.2-12)

• **Time signal output**

Time signal output OFF time and Time signal output ON time are set within one pattern total time. After program control starts, Time signal output activates during Time signal output ON time after Time signal output OFF time has elapsed.

During Wait action or program control Hold, progress time of Time signal output stops.

When Step time is changed during program control RUN, Time signal output timing is re-calculated using the pattern time after change.

**Program pattern setting example**

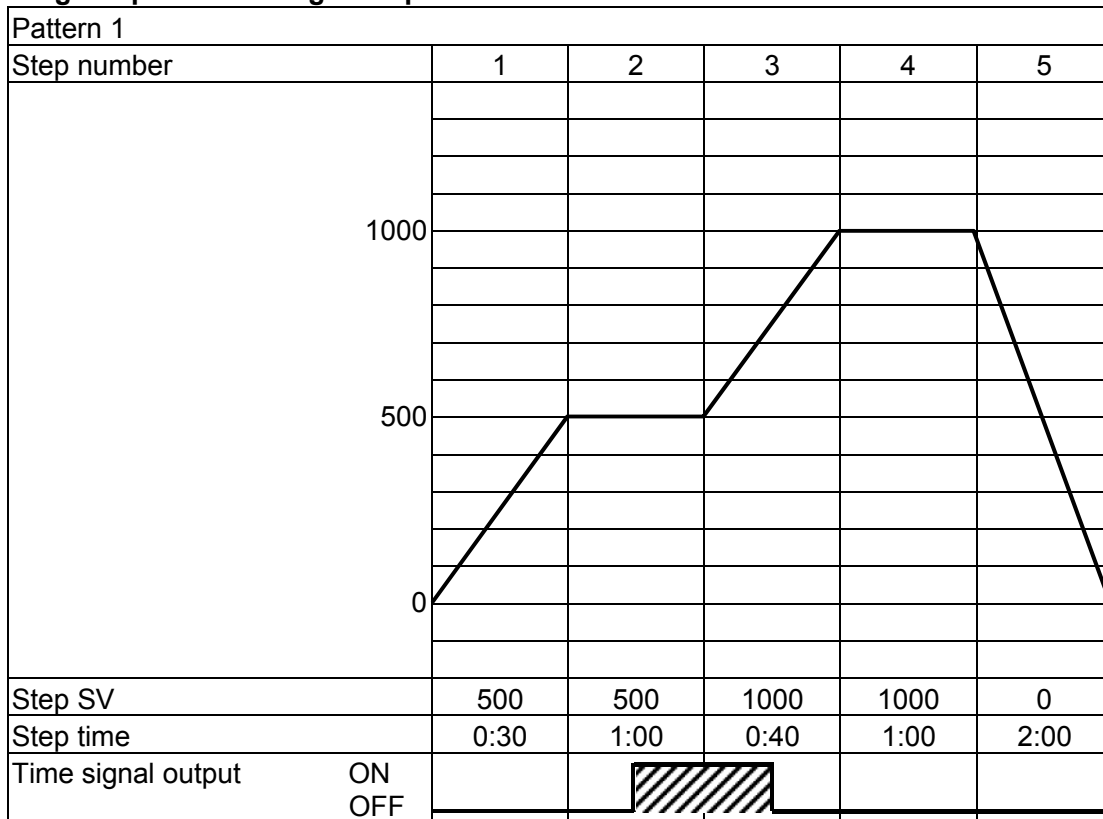

Program control RUN    ON after 1 hour    OFF after 50 minutes

(e.g.) Time signal output setting

Time signal output OFF time: 1 hour

Time signal output ON time: 50 minutes

(Fig. 8.2-13)

**Explanation of Time signal output**

In the above program pattern example, Time signal output turns ON one hour after program control RUN starts (30 minutes after the unit entered Step 2). Time signal output turns OFF 50 minutes after Time signal output turned ON (20 minutes after the unit entered Step 3).



• **Before entering Event setting mode**





















Select a pattern number with the **PTN** key before entering Event setting mode.





• **How to enter Event setting mode**

In RUN mode, press the **MODE** key for approx. 3 seconds to enter Event setting mode.

Setting items in Event Setting mode are shown below.

Characters, Factory Default	Setting Item, Function, Setting Range																								
	<p><b>EV1 alarm value</b></p> <ul style="list-style-type: none"> <li>• Sets EV1 alarm value.</li> </ul> <p>EV1 alarm value matches EV1 low limit alarm value in the following cases:            004 (High/Low limits independent alarm), 006 (High/Low limit range independent alarm) or 012 (High/Low limits with standby independent alarm) is selected in [Event output EV1 allocation].</p> <ul style="list-style-type: none"> <li>• Setting range:</li> </ul> <table style="width: 100%; border-collapse: collapse;"> <tr> <td style="padding-left: 20px;">High limit alarm</td> <td style="text-align: right;">-(Input span) to Input span (*1)</td> </tr> <tr> <td style="padding-left: 20px;">Low limit alarm</td> <td style="text-align: right;">-(Input span) to Input span (*1)</td> </tr> <tr> <td style="padding-left: 20px;">High/Low limits alarm</td> <td style="text-align: right;">0 to Input span (*1)</td> </tr> <tr> <td style="padding-left: 20px;">High/Low limits independent alarm</td> <td style="text-align: right;">0 to Input span (*1)</td> </tr> <tr> <td style="padding-left: 20px;">High/Low limit range alarm</td> <td style="text-align: right;">0 to Input span (*1)</td> </tr> <tr> <td style="padding-left: 20px;">High/Low limit range independent alarm</td> <td style="text-align: right;">0 to Input span (*1)</td> </tr> <tr> <td style="padding-left: 20px;">Process high alarm</td> <td style="text-align: right;">Input range low limit to Input range high limit (*2)</td> </tr> <tr> <td style="padding-left: 20px;">Process low alarm</td> <td style="text-align: right;">Input range low limit to Input range high limit (*2)</td> </tr> <tr> <td style="padding-left: 20px;">High limit with standby alarm</td> <td style="text-align: right;">-(Input span) to Input span (*1)</td> </tr> <tr> <td style="padding-left: 20px;">Low limit with standby alarm</td> <td style="text-align: right;">-(Input span) to Input span (*1)</td> </tr> <tr> <td style="padding-left: 20px;">High/Low limits with standby alarm</td> <td style="text-align: right;">0 to Input span (*1)</td> </tr> <tr> <td style="padding-left: 20px;">High/Low limits with standby independent alarm</td> <td style="text-align: right;">0 to Input span (*1)</td> </tr> </table> <p>(*1) For DC voltage, current inputs, the input span is the same as the scaling span. (The placement of the decimal point follows the selection.)</p> <p>(*2) For DC voltage, current inputs, input range low (or high) limit value is the same as scaling low (or high) limit value. (The placement of the decimal point follows the selection.)</p> <p>Available when <b>0001</b> (High limit alarm) to <b>0012</b> (High/Low limits with standby independent alarm) is selected in [Event output EV1 allocation].</p>	High limit alarm	-(Input span) to Input span (*1)	Low limit alarm	-(Input span) to Input span (*1)	High/Low limits alarm	0 to Input span (*1)	High/Low limits independent alarm	0 to Input span (*1)	High/Low limit range alarm	0 to Input span (*1)	High/Low limit range independent alarm	0 to Input span (*1)	Process high alarm	Input range low limit to Input range high limit (*2)	Process low alarm	Input range low limit to Input range high limit (*2)	High limit with standby alarm	-(Input span) to Input span (*1)	Low limit with standby alarm	-(Input span) to Input span (*1)	High/Low limits with standby alarm	0 to Input span (*1)	High/Low limits with standby independent alarm	0 to Input span (*1)
High limit alarm	-(Input span) to Input span (*1)																								
Low limit alarm	-(Input span) to Input span (*1)																								
High/Low limits alarm	0 to Input span (*1)																								
High/Low limits independent alarm	0 to Input span (*1)																								
High/Low limit range alarm	0 to Input span (*1)																								
High/Low limit range independent alarm	0 to Input span (*1)																								
Process high alarm	Input range low limit to Input range high limit (*2)																								
Process low alarm	Input range low limit to Input range high limit (*2)																								
High limit with standby alarm	-(Input span) to Input span (*1)																								
Low limit with standby alarm	-(Input span) to Input span (*1)																								
High/Low limits with standby alarm	0 to Input span (*1)																								
High/Low limits with standby independent alarm	0 to Input span (*1)																								
	<p><b>EV1 high limit alarm value</b></p> <ul style="list-style-type: none"> <li>• Sets EV1 high limit alarm value.</li> <li>• Setting range: Same as those of EV1 alarm value.</li> </ul> <p>Available when <b>0004</b> (High/Low limits independent alarm), <b>0006</b> (High/Low limit range independent alarm) or <b>0012</b> (High/Low limits with standby independent alarm) is selected in [Event output EV1 allocation].</p>																								
	<p><b>TS1 output OFF time</b></p> <ul style="list-style-type: none"> <li>• Sets TS1 output OFF time.</li> <li>• Setting range:            00:00 to 99:59 (Time unit follows the selection in [Step time unit].)</li> </ul> <p>Available when <b>0015</b> (Time signal output) is selected in [Event output EV1 allocation].</p>																								

Characters, Factory Default	Setting Item, Function, Setting Range
	<p><b>TS1 output ON time</b></p> <ul style="list-style-type: none"> <li>• Sets TS1 output ON time.</li> <li>• Setting range: 00:00 to 99:59 (Time unit follows the selection in [Step time unit].) Available when  (Time signal output) is selected in [Event output EV1 allocation].</li> </ul>
	<p><b>EV2 alarm value</b></p> <ul style="list-style-type: none"> <li>• Sets EV2 alarm value. EV2 alarm value matches EV2 low limit alarm value in the following cases: 004 (High/Low limits independent alarm), 006 (High/Low limit range independent alarm) or 012 (High/Low limits with standby independent alarm) is selected in [Event output EV2 allocation].</li> <li>• Setting range: Same as those of EV1 alarm value. Available when  (High limit alarm) to  (High/Low limits with standby independent alarm) is selected in [Event output EV2 allocation].</li> </ul>
	<p><b>EV2 high limit alarm value</b></p> <ul style="list-style-type: none"> <li>• Sets EV2 high limit alarm value.</li> <li>• Setting range: Same as those of EV1 alarm value. Available when  (High/Low limits independent alarm),  (High/Low limit range independent alarm) or  (High/Low limits with standby independent alarm) is selected in [Event output EV2 allocation].</li> </ul>
	<p><b>TS2 output OFF time</b></p> <ul style="list-style-type: none"> <li>• Sets TS2 output OFF time.</li> <li>• Setting range: 00:00 to 99:59 (Time unit follows the selection in [Step time unit].) Available when  (Time signal output) is selected in [Event output EV2 allocation].</li> </ul>
	<p><b>TS2 output ON time</b></p> <ul style="list-style-type: none"> <li>• Sets TS2 output ON time.</li> <li>• Setting range: 00:00 to 99:59 (Time unit follows the selection in [Step time unit].) Available when  (Time signal output) is selected in [Event output EV2 allocation].</li> </ul>
	<p><b>EV3 alarm value</b></p> <ul style="list-style-type: none"> <li>• Sets EV3 alarm value. EV3 alarm value matches EV3 low limit alarm value in the following cases: 004 (High/Low limits independent alarm), 006 (High/Low limit range independent alarm) or 012 (High/Low limits with standby independent alarm) is selected in [Event output EV3 allocation].</li> <li>• Setting range: Same as those of EV1 alarm value. Available when  (High limit alarm) to  (High/Low limits with standby independent alarm) is selected in [Event output EV3 allocation].</li> </ul>
	<p><b>EV3 high limit alarm value</b></p> <ul style="list-style-type: none"> <li>• Sets EV3 high limit alarm value.</li> <li>• Setting range: Same as those of EV1 alarm value. Available when  (High/Low limits independent alarm),  (High/Low limit range independent alarm) or  (High/Low limits with standby independent alarm) is selected in [Event output EV3 allocation].</li> </ul>

Characters, Factory Default	Setting Item, Function, Setting Range
	<p><b>TS3 output OFF time</b></p> <ul style="list-style-type: none"> <li>• Sets TS3 output OFF time.</li> <li>• Setting range: 00:00 to 99:59 (Time unit follows the selection in [Step time unit].) Available when  (Time signal output) is selected in [Event output EV3 allocation].</li> </ul>
	<p><b>TS3 output ON time</b></p> <ul style="list-style-type: none"> <li>• Sets TS3 output ON time.</li> <li>• Setting range: 00:00 to 99:59 (Time unit follows the selection in [Step time unit].) Available when  (Time signal output) is selected in [Event output EV3 allocation].</li> </ul>

At this stage, settings for Event setting mode are complete.

Press the  key. The unit reverts to RUN mode.

### 8.3 Setting Items in Control Parameter Setting Mode





In Control parameter setting mode, the following setting items can be set:

AT Perform/Cancel, OUT1 proportional band, Integral time, derivative time, ARW, OUT2 proportional band (when EV2, DS, DA or EV3D□ option is ordered), Direct/Reverse action, Loop break alarm, etc. Setting data is common to all patterns.





#### • How to enter Control parameter setting mode

In RUN mode, press the  and **MODE** keys (in that order) together. The unit enters Control parameter setting mode.

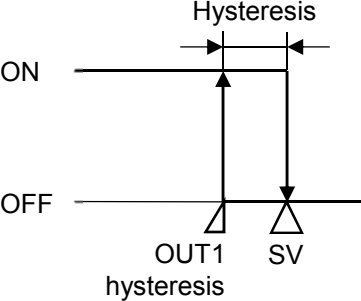

Setting items in Control parameter setting mode are shown below.

Characters, Factory Default	Setting Item, Function, Setting Range
	<p><b>AT Perform/Cancel</b></p> <ul style="list-style-type: none"> <li>• Selects AT (auto-tuning) Perform/Cancel. AT will work only during program control RUN. After AT starts, and if AT has not been completed within 4 hours, or if input errors have occurred,  will be indicated on the PV Display, and AT will be forced to stop.</li> <li>• Selection item:</li> </ul>
	<p style="text-align: center;">- - - -</p> <p style="text-align: center;">AT Cancel</p>
	<p style="text-align: center;"></p> <p style="text-align: center;">AT Perform</p>
	<p><b>PID block number</b></p> <ul style="list-style-type: none"> <li>• Selects a PID block number from 1 to 10 for the following settings: OUT1 proportional band, Integral time, Derivative time, ARW, OUT2 proportional band [EV2(DR), DS, DA, EV3D□ options]</li> </ul> <p>Refer to recommended usage of block numbers as follows:</p> <ul style="list-style-type: none"> <li>Block 1: For Fixed value control</li> <li>Block 2: For low temperature program control</li> <li>Block 3: For medium temperature program control</li> <li>Block 4: For high temperature program control</li> </ul> <ul style="list-style-type: none"> <li>• Selection item:</li> </ul> <p style="text-align: center;">1 to 10</p>

Characters, Factory Default	Setting Item, Function, Setting Range
P000   00 10	<p><b>OUT1 proportional band</b></p> <ul style="list-style-type: none"> <li>• Sets OUT1 proportional band for the PID block number selected in [PID block number].</li> </ul> <p>The PTN/STEP Display indicates the PID block number selected in [PID block number].</p> <p>OUT1 becomes ON/OFF control when set to 0 or 0.0.</p> <div data-bbox="539 510 906 792" data-label="Diagram"> </div> <p>(Fig. 8.3-1)</p> <ul style="list-style-type: none"> <li>• Setting range:            Thermocouple, RTD input without decimal point: 0 to input span<math>^{\circ}\text{C}</math> (<math>^{\circ}\text{F}</math>)            Thermocouple, RTD input with decimal point: 0.0 to input span<math>^{\circ}\text{C}</math> (<math>^{\circ}\text{F}</math>)            DC voltage, current inputs: 0.0 to 1000.0%</li> </ul>
I 000   0200	<p><b>Integral time</b></p> <ul style="list-style-type: none"> <li>• Sets the integral time of the PID block number selected in [PID block number].</li> </ul> <p>The PTN/STEP Display indicates the PID block number selected in [PID block number].</p> <ul style="list-style-type: none"> <li>• Setting range: 0 to 3600 seconds</li> </ul>
d000   0050	<p><b>Derivative time</b></p> <ul style="list-style-type: none"> <li>• Sets the derivative time of the PID block number selected in [PID block number].</li> </ul> <p>The PTN/STEP Display indicates the PID block number selected in [PID block number].</p> <ul style="list-style-type: none"> <li>• Setting range: 0 to 1800 seconds</li> </ul>
A-00   0050	<p><b>ARW</b></p> <ul style="list-style-type: none"> <li>• Sets the ARW of the PID block number selected in [PID block number].</li> </ul> <p>The PTN/STEP Display indicates the PID block number selected in [PID block number].</p> <ul style="list-style-type: none"> <li>• Setting range: 0 to 100%</li> </ul>

Characters, Factory Default	Setting Item, Function, Setting Range
	<p><b>OUT1 proportional cycle</b></p> <ul style="list-style-type: none"> <li>Sets OUT1 proportional cycle.</li> </ul> <p>For relay contact output, if the proportional cycle time is decreased, the frequency of the relay action increases, and the life of the relay contact is shortened.</p> <p>Factory default value is different depending on the output type.</p> <ul style="list-style-type: none"> <li>Relay contact output: 30 seconds</li> <li>Non-contact voltage output: 3 seconds</li> <li>Direct current output: Not available</li> </ul> <ul style="list-style-type: none"> <li>Setting range: <ul style="list-style-type: none"> <li>0.5, 1 to 120 seconds</li> </ul> </li> </ul> <p>Available when OUT1 is relay contact output or non-contact voltage output type.</p>
	<p><b>OUT1 ON/OFF hysteresis</b></p> <ul style="list-style-type: none"> <li>Sets ON/OFF hysteresis for OUT1.</li> </ul>  <p>(Fig. 8.3-2)</p> <ul style="list-style-type: none"> <li>Setting range: <ul style="list-style-type: none"> <li>0.1 to 1000.0°C (°F)</li> <li>DC voltage, current inputs: 1 to 10000 (The placement of the decimal point follows the selection.)</li> </ul> </li> </ul>
	<p><b>OUT1 high limit</b></p> <ul style="list-style-type: none"> <li>Sets OUT1 high limit value.</li> <li>Setting range: <ul style="list-style-type: none"> <li>OUT1 low limit to 100%</li> <li>Direct current output type: OUT1 low limit to 105%</li> </ul> </li> </ul>
	<p><b>OUT1 low limit</b></p> <ul style="list-style-type: none"> <li>Sets OUT1 low limit value.</li> <li>Setting range: <ul style="list-style-type: none"> <li>0% to OUT1 high limit</li> <li>Direct current output type: -5% to OUT1 high limit</li> </ul> </li> </ul>



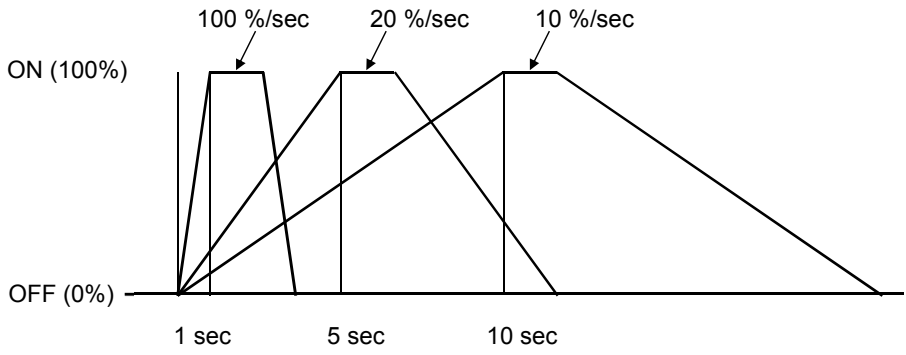

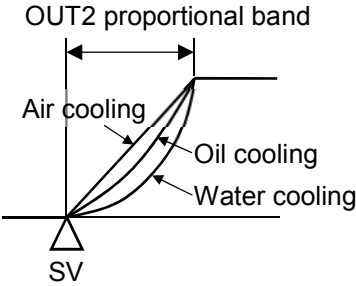
Characters, Factory Default	Setting Item, Function, Setting Range
	<p><b>OUT1 rate-of-change</b></p> <ul style="list-style-type: none"> <li>• Sets changing value of OUT1 MV for 1 second. Setting the value to 0 disables this function.</li> <li>• About OUT1 rate-of-change: For Heating control, if PV is lower than SV, OUT1 MV is generally turned from OFF to ON as shown in (Fig. 8.3-3). If OUT1 rate-of-change is set, OUT1 MV can be changed by the rate-of-change as shown in (Fig. 8.3-4). This control is suitable for high temperature heaters (which are made from molybdenum, tungsten or platinum, etc., and used at approx. 1500 to 1800°C) which are easily burnt out from turning on electricity rapidly.</li> <li>• Setting range: 0 to 100 %/second Not available if OUT1 is in ON/OFF control.</li> </ul> <div style="text-align: center;">  <p>(Fig. 8.3-3)</p> </div> <div style="text-align: center;">  <p>(Fig. 8.3-4)</p> </div> <ul style="list-style-type: none"> <li>• Setting range: 0 to 100 %/second</li> </ul>

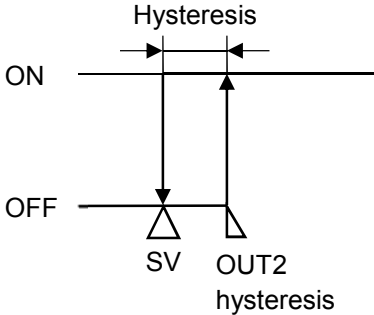
Characters, Factory Default	Setting Item, Function, Setting Range						
eAcI 0 Air0	<p><b>OUT2 cooling method</b></p> <ul style="list-style-type: none"> <li>• Selects OUT2 cooling method from air, oil or water cooling.</li> </ul>  <p>(Fig. 8.3-5)</p> <ul style="list-style-type: none"> <li>• Selection item:</li> </ul> <table border="1" data-bbox="464 757 1481 880"> <tr> <td data-bbox="464 757 608 792">Air0</td> <td data-bbox="608 757 1481 792">Air cooling (Linear characteristics)</td> </tr> <tr> <td data-bbox="464 792 608 828">oL0</td> <td data-bbox="608 792 1481 828">Oil cooling (1.5th power of the linear characteristics)</td> </tr> <tr> <td data-bbox="464 828 608 864">wR0</td> <td data-bbox="608 828 1481 864">Water cooling (2nd power of the linear characteristics)</td> </tr> </table> <p>Available when EV2 option {When 0020 (Heating/Cooling control output) is selected in [Event output EV2 allocation]} is ordered, or when DS, DA or EV3D□ option is ordered.</p>	Air0	Air cooling (Linear characteristics)	oL0	Oil cooling (1.5th power of the linear characteristics)	wR0	Water cooling (2nd power of the linear characteristics)
Air0	Air cooling (Linear characteristics)						
oL0	Oil cooling (1.5th power of the linear characteristics)						
wR0	Water cooling (2nd power of the linear characteristics)						
P_b0 1 00 10	<p><b>OUT2 proportional band</b></p> <ul style="list-style-type: none"> <li>• Sets the OUT2 proportional band of the PID block number selected in [PID block number].</li> </ul> <p>The PTN/STEP Display indicates the PID block number selected in [PID block number].</p> <p>When set to 0 or 0.0, OUT2 becomes ON/OFF control, and the action selected in [OUT2 cooling method] will be disabled.</p> <ul style="list-style-type: none"> <li>• Setting range:</li> </ul> <p>Thermocouple, RTD input without decimal point: 0 to Input span°C (°F)      Thermocouple, RTD input with decimal point: 0.0 to Input span°C (°F)      DC voltage, current inputs: 0.0 to 1000.0%</p> <p>Available when EV2 option {When 0020 (Heating/Cooling control output) is selected in [Event output EV2 allocation]} is ordered, or when DS, DA or EV3D□ option is ordered.</p>						
e_b0 00003	<p><b>OUT2 proportional cycle</b></p> <ul style="list-style-type: none"> <li>• Sets OUT2 proportional cycle.</li> </ul> <p>For relay contact output, if the proportional cycle time is decreased, the frequency of the relay action increases, and the life of the relay contact is shortened.</p> <p>Factory default value is different depending on the output type as follows:</p> <ul style="list-style-type: none"> <li>Relay contact output [EV2, EV3(DR)]: 30 seconds</li> <li>Non-contact voltage output (DS, EV3DS): 3 seconds</li> <li>Direct current output (DA, EV3DA): Not available</li> </ul> <ul style="list-style-type: none"> <li>• Setting range: 0.5, 1 to 120 seconds</li> </ul> <p>Available when EV2 option {When 0020 (Heating/Cooling control output) is selected in [Event output EV2 allocation]} is ordered, or when DS, EV3(DR), EV3DS option is ordered.</p>						

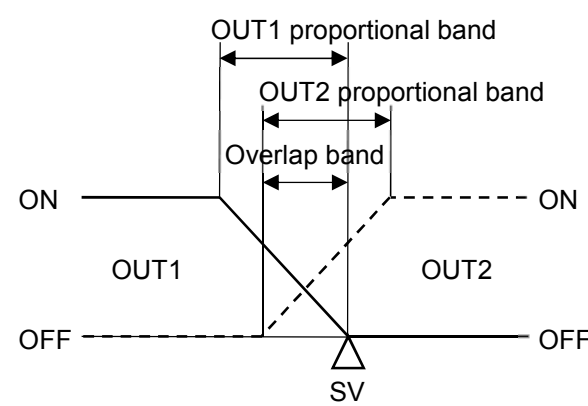
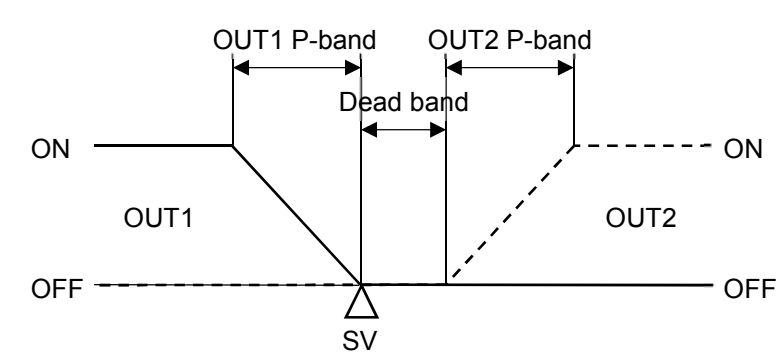
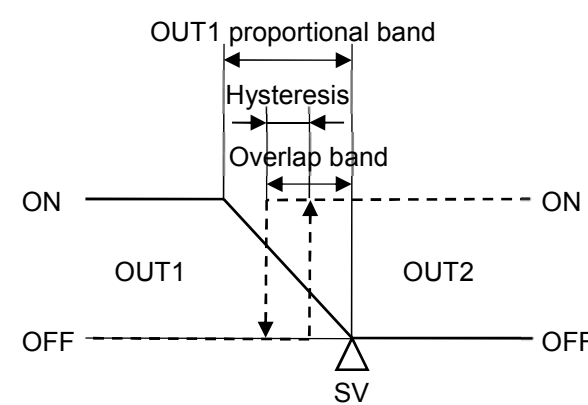
Characters, Factory Default	Setting Item, Function, Setting Range
<p><b>HYSb</b> 0 00 0</p>	<p><b>OUT2 ON/OFF hysteresis</b></p> <ul style="list-style-type: none"> <li>• Sets OUT2 ON/OFF hysteresis.</li> </ul>  <p>(Fig. 8.3-6)</p> <ul style="list-style-type: none"> <li>• Setting range: 0.1 to 1000.0°C (°F) DC voltage, current inputs: 1 to 10000 (The placement of the decimal point follows the selection.)</li> </ul> <p>Available when EV2 option {When 0020 (Heating/Cooling control output) is selected in [Event output EV2 allocation]} is ordered, or when DS, DA or EV3D□ option is ordered.</p>
<p><b>oLHb</b> 0 0 100</p>	<p><b>OUT2 high limit</b></p> <ul style="list-style-type: none"> <li>• Sets OUT2 high limit value.</li> <li>• Setting range: OUT2 low limit value to 100% Direct current output type (DA, EV3DA options): OUT2 low limit value to 105%</li> </ul> <p>Available when EV2 option {When 0020 (Heating/Cooling control output) is selected in [Event output EV2 allocation]} is ordered, or when DS, DA or EV3D□ option is ordered.</p>
<p><b>oLLb</b> 0 0000</p>	<p><b>OUT2 low limit</b></p> <ul style="list-style-type: none"> <li>• Sets OUT2 low limit value.</li> <li>• Setting range: 0% to OUT2 high limit value Direct current output type (DA, EV3DA options): -5% to OUT2 high limit value</li> </ul> <p>Available when EV2 option {When 0020 (Heating/Cooling control output) is selected in [Event output EV2 allocation]} is ordered, or when DS, DA or EV3D□ option is ordered.</p>

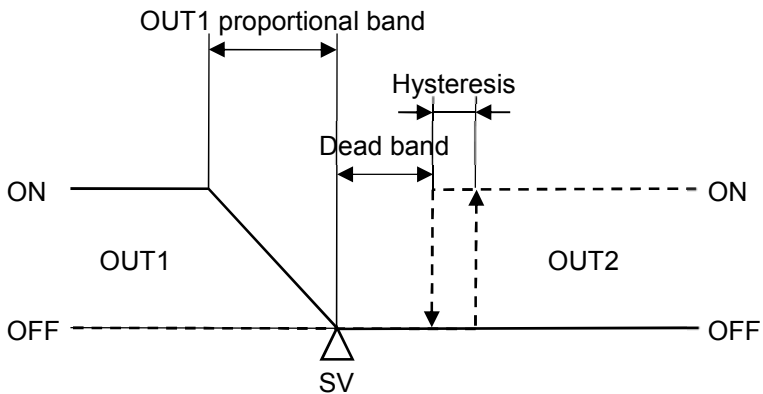
Characters, Factory Default	Setting Item, Function, Setting Range
	<p><b>Overlap/Dead band</b></p> <ul style="list-style-type: none"> <li>• Sets the overlap band or dead band for OUT1 and OUT2.</li> <li>+ Set value: Dead band</li> <li>- Set value: Overlap band</li> </ul> <p>Overlap band (When OUT1 and OUT2 are in PID control)</p>  <p>(Fig. 8.3-7)</p> <p>Dead band (When OUT1 and OUT2 are in PID control)</p>  <p>(Fig. 8.3-8)</p> <p>Overlap band (When OUT1 is in PID control, OUT2 is in ON/OFF control)</p>  <p>(Fig. 8.3-9)</p>

Characters, Factory Default	Setting Item, Function, Setting Range				
	<p>Dead band (When OUT1 is in PID control, OUT2 is in ON/OFF control)</p>  <p>(Fig. 8.3-10)</p> <ul style="list-style-type: none"> <li>• Setting range: -200.0 to 200.0°C (°F)</li> <li>DC voltage, current inputs: -2000 to 2000 (The placement of the decimal point follows the selection.)</li> </ul> <p>Available when EV2 option {When <math>\square 020</math> (Heating/Cooling control output) is selected in [Event output EV2 allocation]} is ordered, or when DS, DA or EV3D□ option is ordered.</p>				
<p><math>\text{cool}</math> <math>\square \text{HEAT}</math></p>	<p><b>Direct/Reverse action</b></p> <ul style="list-style-type: none"> <li>• Selects either Direct (Cooling) or Reverse (Heating) control action.</li> <li>• Selection range:</li> </ul> <table border="1" data-bbox="478 1153 925 1232"> <tr> <td><math>\text{HEAT}</math></td> <td>Reverse (Heating) action</td> </tr> <tr> <td><math>\text{cool}</math></td> <td>Direct (Cooling) action</td> </tr> </table>	$\text{HEAT}$	Reverse (Heating) action	$\text{cool}$	Direct (Cooling) action
$\text{HEAT}$	Reverse (Heating) action				
$\text{cool}$	Direct (Cooling) action				
<p><math>\text{H } \square \square \square</math> <math>\square \square \square \square</math> <math>\text{H } \square \square</math> and CT1 current value are alternately indicated.</p>	<p><b>Heater burnout alarm 1 value</b></p> <ul style="list-style-type: none"> <li>• Sets the detecting current value for Heater burnout alarm 1.</li> </ul> <p>When setting to 0.0, Heater burnout alarm 1 is disabled.</p> <p>Characters <math>\text{H } \square \square \square</math> and CT1 current value are indicated alternately on the PV Display.</p> <p>When OUT1 is ON, the CT1 current value is updated.</p> <p>When OUT1 is OFF, the unit memorizes the previous value when OUT1 was ON.</p> <p>Upon returning to set limits, the alarm will stop.</p> <ul style="list-style-type: none"> <li>• Setting range:</li> </ul> <p>20 A: 0.0 to 20.0 A 100 A: 0.0 to 100.0 A</p> <p>Available when C5W, EIW, W option is ordered, and when OUT1 is relay contact output or non-contact voltage output type.</p>				
<p><math>\text{H2} \square \square \square</math> <math>\square \square \square \square</math> <math>\text{H2} \square \square</math> and CT2 current value are alternately indicated.</p>	<p><b>Heater burnout alarm 2 value</b></p> <ul style="list-style-type: none"> <li>• Sets the detecting current value for Heater burnout alarm 2.</li> </ul> <p>Available only when using 3-phase.</p> <p>When setting to 0.0, Heater burnout alarm 2 is disabled.</p> <p>Characters <math>\text{H2} \square \square \square</math> and CT2 current value are indicated alternately on the PV Display.</p> <p>When OUT1 is ON, the CT2 current value is updated.</p>				

Characters, Factory Default	Setting Item, Function, Setting Range
	<p>When OUT1 is OFF, the unit memorizes the previous value when OUT1 was ON.</p> <p>Upon returning to set limits, the alarm will stop.</p> <ul style="list-style-type: none"> <li>Setting range: <ul style="list-style-type: none"> <li>20 A: 0.0 to 20.0 A</li> <li>100 A: 0.0 to 100.0 A</li> </ul> </li> </ul> <p>Available when C5W, EIW, W option is ordered, and when OUT1 is relay contact output or non-contact voltage output type.</p>
<pre> LP_I 0 0000 </pre>	<p><b>Loop break alarm time</b></p> <ul style="list-style-type: none"> <li>Sets the time to assess the Loop break alarm.</li> <li>Setting to 0 (zero) disables the alarm.</li> <li>Loop break alarm: <p><b>When the control action is Reverse (Heating) control:</b></p> <p>If the PV does not reach the Loop break alarm span setting within the time allotted to assess the Loop break alarm (after the MV has reached 100% or the OUT high limit value), the alarm will be activated.</p> <p>Likewise, if the PV does not drop to the Loop break alarm span setting within the time allotted to assess the Loop break alarm (after the MV has reached 0% or the OUT low limit value), the alarm will be activated.</p> <p><b>When the control action is Direct (Cooling) control:</b></p> <p>If the PV does not drop to the Loop break alarm span setting within the time allotted to assess the Loop break alarm (after the MV has reached 100% or the OUT high limit value), the alarm will be activated.</p> <p>Likewise, if the PV does not reach the Loop break alarm span setting within the time allotted to assess the Loop break alarm (after the MV has reached 0% or the OUT low limit value), the alarm will be activated.</p> </li> </ul> <ul style="list-style-type: none"> <li>Setting range: <ul style="list-style-type: none"> <li>0 to 200 minutes</li> </ul> </li> </ul> <p>Available when  (Loop break alarm output) is selected in [Event output EV□ allocation].</p>
<pre> LP_H 0 0000 </pre>	<p><b>Loop break alarm span</b></p> <ul style="list-style-type: none"> <li>Sets the action span to assess the Loop break alarm.</li> <li>Setting range: <ul style="list-style-type: none"> <li>Thermocouple, RTD input without decimal point: 0 to 150°C (°F)</li> <li>Thermocouple, RTD input with decimal point: 0.0 to 150.0°C (°F)</li> <li>DC voltage, current inputs: 0 to 1500 (The placement of the decimal point follows the selection.)</li> </ul> </li> </ul> <p>Available when  (Loop break alarm output) is selected in [Event output EV□ allocation].</p>

At this stage, settings for Control parameter setting mode are complete.

Press the **RST** key. The unit reverts to RUN mode.

## 8.4 Setting Items in Wait Parameter Setting Mode

In Wait parameter setting mode, the following setting items can be set:

Wait value, Wait function Enabled/Disabled for each step

Settings are performed for the pattern number selected when entering Wait parameter setting mode.

Setting data is common to all steps in each pattern.

During program control RUN, only the performing pattern can be set.

If 'Pattern link Enabled' is selected in [Pattern link]: Even if the performing pattern is changed from 1 to 2 during Wait parameter setting mode, Pattern 1 will be remained, and pattern number will not be updated until the unit reverts to the RUN mode.

### • Wait function

During program control RUN, the program does not proceed to the next step until the deviation between PV and SV enters  $SV \pm \text{Wait value}$  at the end of step.

The PV Display and PTN/STEP Display flash while the Wait function is activated.

### • Explanation of Wait Function

#### • Program pattern rising step:

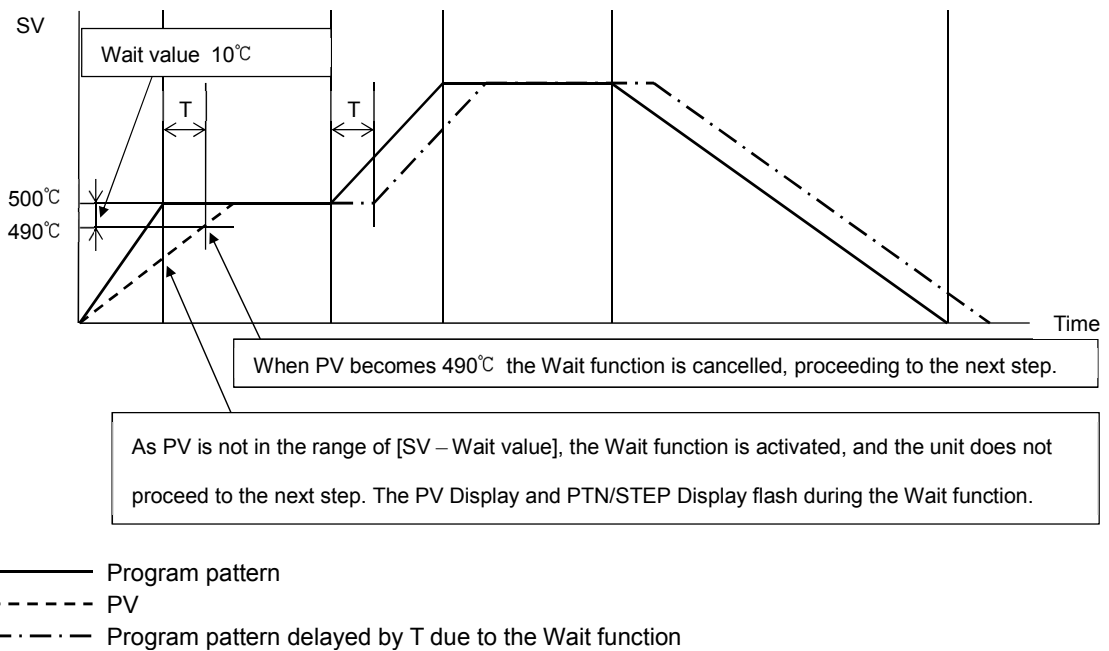

(Fig. 8.4-1)

• **Program pattern falling step:**

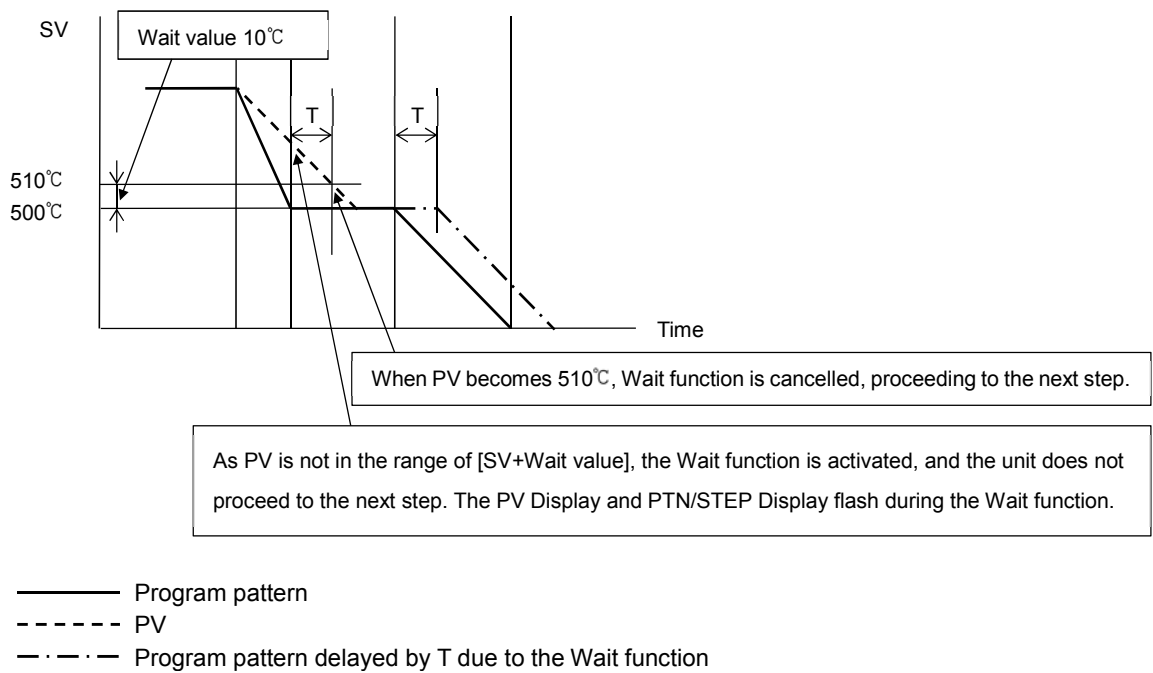

(Fig. 8.4-2)

• **How to cancel the Wait function**

Press the **RUN** key for approx. 1 second to cancel the Wait function.

• **Before entering Wait parameter setting mode**

Select a pattern number with the **PTN** key before entering Wait parameter setting mode.

• **How to enter Wait parameter setting mode**

In RUN mode, press the **▲** and **▼** key (in that order) together for approx. 3 seconds.

The unit enters Wait parameter setting mode.

Setting items in Wait parameter setting mode are shown below.

Characters, Factory Default	Setting Item, Function, Setting Range
	<p><b>Wait value</b></p> <ul style="list-style-type: none"> <li>• Sets the Wait value.</li> <li>Wait value is common to all steps for each pattern.</li> <li>When set to 0 or 0.0, the Wait function is disabled.</li> <li>• Setting range: 0 to 20% of input span (*)</li> <li>(*) DC voltage, current inputs: 0 to 20% of scaling span (The placement of the decimal point follows the selection.)</li> </ul>

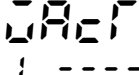
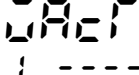
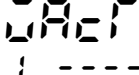
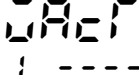
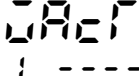
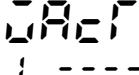

Characters, Factory Default	Setting Item, Function, Setting Range				
 PTN/STEP indicator 1 lights up.	<p><b>Step 1 wait function Enabled/Disabled</b></p> <ul style="list-style-type: none"> <li>• Selects the wait function Enabled or Disabled at Step 1, based on the wait value set in [Wait value].</li> <li>• Selection item:</li> </ul> <table border="1" data-bbox="461 398 735 479"> <tr> <td>----</td> <td>Disabled</td> </tr> <tr> <td>USE0</td> <td>Enabled</td> </tr> </table> <p>Not available if wait value is set to 0 or 0.0.</p>	----	Disabled	USE0	Enabled
----	Disabled				
USE0	Enabled				
 PTN/STEP indicator 2 lights up.	<p><b>Step 2 wait function Enabled/Disabled</b></p> <ul style="list-style-type: none"> <li>• Selects the wait function Enabled or Disabled at Step 2, based on the wait value set in [Wait value].</li> <li>• Selection item:</li> </ul> <table border="1" data-bbox="461 683 735 763"> <tr> <td>----</td> <td>Disabled</td> </tr> <tr> <td>USE0</td> <td>Enabled</td> </tr> </table> <p>Not available if wait value is set to 0 or 0.0.</p>	----	Disabled	USE0	Enabled
----	Disabled				
USE0	Enabled				
 PTN/STEP indicator 3 lights up.	<p><b>Step 3 wait function Enabled/Disabled</b></p> <ul style="list-style-type: none"> <li>• Selects the wait function Enabled or Disabled at Step 3, based on the wait value set in [Wait value].</li> <li>• Selection item:</li> </ul> <table border="1" data-bbox="461 967 735 1048"> <tr> <td>----</td> <td>Disabled</td> </tr> <tr> <td>USE0</td> <td>Enabled</td> </tr> </table> <p>Not available if wait value is set to 0 or 0.0.</p>	----	Disabled	USE0	Enabled
----	Disabled				
USE0	Enabled				
 PTN/STEP indicator 4 lights up.	<p><b>Step 4 wait function Enabled/Disabled</b></p> <ul style="list-style-type: none"> <li>• Selects the wait function Enabled or Disabled at Step 4, based on the wait value set in [Wait value].</li> <li>• Selection item:</li> </ul> <table border="1" data-bbox="461 1252 735 1332"> <tr> <td>----</td> <td>Disabled</td> </tr> <tr> <td>USE0</td> <td>Enabled</td> </tr> </table> <p>Not available if wait value is set to 0 or 0.0.</p>	----	Disabled	USE0	Enabled
----	Disabled				
USE0	Enabled				
 PTN/STEP indicator 5 lights up.	<p><b>Step 5 wait function Enabled/Disabled</b></p> <ul style="list-style-type: none"> <li>• Selects the wait function Enabled or Disabled at Step 5, based on the wait value set in [Wait value].</li> <li>• Selection item:</li> </ul> <table border="1" data-bbox="461 1536 735 1617"> <tr> <td>----</td> <td>Disabled</td> </tr> <tr> <td>USE0</td> <td>Enabled</td> </tr> </table> <p>Not available if wait value is set to 0 or 0.0.</p>	----	Disabled	USE0	Enabled
----	Disabled				
USE0	Enabled				
 PTN/STEP indicator 6 lights up.	<p><b>Step 6 wait function Enabled/Disabled</b></p> <ul style="list-style-type: none"> <li>• Selects the wait function Enabled or Disabled at Step 6, based on the wait value set in [Wait value].</li> <li>• Selection item:</li> </ul> <table border="1" data-bbox="461 1821 735 1901"> <tr> <td>----</td> <td>Disabled</td> </tr> <tr> <td>USE0</td> <td>Enabled</td> </tr> </table> <p>Not available if wait value is set to 0 or 0.0.</p>	----	Disabled	USE0	Enabled
----	Disabled				
USE0	Enabled				

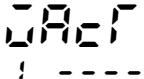
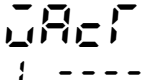
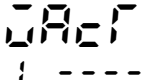
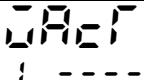
Characters, Factory Default	Setting Item, Function, Setting Range					
 <p>PTN/STEP indicator 7 lights up.</p>	<p><b>Step 7 wait function Enabled/Disabled</b></p> <ul style="list-style-type: none"> <li>• Selects the wait function Enabled or Disabled at Step 7, based on the wait value set in [Wait value].</li> <li>• Selection item:</li> </ul> <table border="1" data-bbox="451 398 603 479"> <tr> <td>----</td> <td>Disabled</td> </tr> <tr> <td>USE0</td> <td>Enabled</td> </tr> </table> <p>Not available if wait value is set to 0 or 0.0.</p>		----	Disabled	USE0	Enabled
----	Disabled					
USE0	Enabled					
 <p>PTN/STEP indicator 8 lights up.</p>	<p><b>Step 8 wait function Enabled/Disabled</b></p> <ul style="list-style-type: none"> <li>• Selects the wait function Enabled or Disabled at Step 8, based on the wait value set in [Wait value].</li> <li>• Selection item:</li> </ul> <table border="1" data-bbox="451 685 603 766"> <tr> <td>----</td> <td>Disabled</td> </tr> <tr> <td>USE0</td> <td>Enabled</td> </tr> </table> <p>Not available if wait value is set to 0 or 0.0.</p>		----	Disabled	USE0	Enabled
----	Disabled					
USE0	Enabled					
 <p>PTN/STEP indicator 9 lights up.</p>	<p><b>Step 9 wait function Enabled/Disabled</b></p> <ul style="list-style-type: none"> <li>• Selects the wait function Enabled or Disabled at Step 9, based on the wait value set in [Wait value].</li> <li>• Selection item:</li> </ul> <table border="1" data-bbox="451 969 603 1050"> <tr> <td>----</td> <td>Disabled</td> </tr> <tr> <td>USE0</td> <td>Enabled</td> </tr> </table> <p>Not available if wait value is set to 0 or 0.0.</p>		----	Disabled	USE0	Enabled
----	Disabled					
USE0	Enabled					
 <p>PTN/STEP indicator 10 lights up.</p>	<p><b>Step 10 wait function Enabled/Disabled</b></p> <ul style="list-style-type: none"> <li>• Selects the wait function Enabled or Disabled at Step 10, based on the wait value set in [Wait value].</li> <li>• Selection item:</li> </ul> <table border="1" data-bbox="451 1256 603 1337"> <tr> <td>----</td> <td>Disabled</td> </tr> <tr> <td>USE0</td> <td>Enabled</td> </tr> </table> <p>Not available if wait value is set to 0 or 0.0.</p>		----	Disabled	USE0	Enabled
----	Disabled					
USE0	Enabled					

At this stage, settings for Wait parameter setting mode are complete.

Press the **RST** key. The unit reverts to RUN mode.

## 8.5 Setting Items in Engineering Setting Mode 1

In Engineering setting mode 1, the following setting items can be set:



Set value lock, Sensor correction, PV filter time constant, Communication parameters (When C5W or C5 option is ordered)

Setting data is common to all patterns.

### • How to enter Engineering setting mode 1

In RUN mode, press the  and **MODE** key (in that order) together for approx. 3 seconds to enter Engineering setting mode 1.

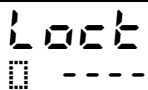
Setting items in Engineering setting mode 1 are shown below.

Characters, Factory Default	Setting Item, Function, Setting Range			
	<b>Set value lock</b> • Locks the set values to prevent setting errors. The setting item to be locked depends on the selection. • Selection item:			
			<b>Change via Keypad</b>	<b>Change via Software Communication</b>
	----	Unlock	All set values can be changed.	All set values can be changed.
	Loc 1	Lock 1	Only 'Set value lock' can be changed. Other setting items cannot be changed.	
	Loc 2	Lock 2	Setting items selected in [Changeable in Set value lock] can be changed. Only 'Set value lock' can be changed.	
	Loc 3	Lock 3	All set values can be changed.	Setting items – except Input type – can be changed temporarily via software communication. However, if power is turned ON again, the set values revert to the values before Lock 3, 4 or 5 was selected.
	Loc 4	Lock 4	Only 'Set value lock' can be changed. Other setting items cannot be changed.	
	Loc 5	Lock 5	Setting items selected in [Changeable in Set value lock] can be changed. Only 'Set value lock' can be changed.	
	<b>Changeable in Set value lock</b> • When Loc 2 (Lock 2) or Loc 5 (Lock 5) is selected in [Set value lock], the following items can be changed. • Selection item:			
	5800	Step SV and Step time can be changed.		
	58E8	Step SV, Step time and EV <input type="checkbox"/> alarm value can be changed.		

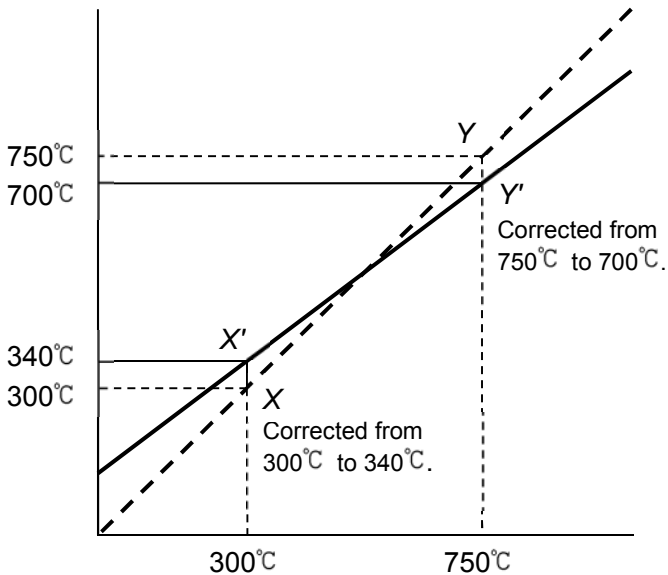
Characters, Factory Default	Setting Item, Function, Setting Range
Set 0000	<p><b>Sensor correction coefficient</b></p> <ul style="list-style-type: none"> <li>Sets sensor correction coefficient.</li> <li>Sets slope of input value from a sensor.</li> </ul>  <p>Corrected from 300°C to 340°C.</p> <p>Corrected from 750°C to 700°C.</p> <p>--- Slope before correction        — Slope after correction</p> $\frac{Y' - X'}{Y - X} = \text{Sensor correction coefficient}$ <p>(Fig. 8.5-1)</p> <p>PV after sensor correction = Current PV x (Sensor correction coefficient) + (Sensor correction value)</p> <p>Refer to Section '9.5 Input Value Correction' (pp.102, 103).</p> <ul style="list-style-type: none"> <li>Setting range: -10.000 to 10.000</li> </ul>
Set 0000	<p><b>Sensor correction</b></p> <ul style="list-style-type: none"> <li>This corrects the input value from the sensor.</li> </ul> <p>When a sensor cannot be set at the exact location where control is desired, the sensor-measured temperature may deviate from the temperature in the controlled location. When using multiple controllers, sometimes the measured temperatures do not concur due to differences in sensor accuracy or dispersion of load capacities. In such a case, the control can be set at the desired temperature by adjusting the input value of sensors.</p> <p>PV after sensor correction = Current PV x (Sensor correction coefficient) + (Sensor correction value)</p> <p>Refer to Section '9.5 Input Value Correction' (pp.102, 103).</p> <ul style="list-style-type: none"> <li>Setting range: -1000.0 to 1000.0°C (°F)</li> </ul> <p>DC voltage, current inputs: -10000 to 10000 (The placement of the decimal point follows the selection.)</p>

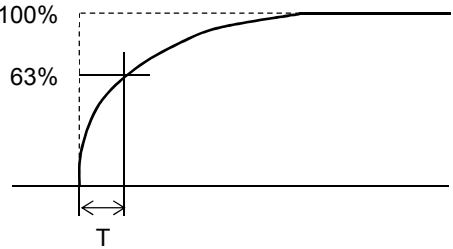
Characters, Factory Default	Setting Item, Function, Setting Range										
F11 0 0000	<p><b>PV filter time constant</b></p> <ul style="list-style-type: none"> <li>• Sets PV filter time constant.</li> </ul> <p>If the value is set too high, it affects control results due to the delay of response.</p> <p><b>About PV filter time constant</b></p> <p>This is a filter function on the software, which has the same effect as a CR filter. By calculating first-order lag of PV, this suppresses input fluctuation caused by noise.</p> <p>When the input value changes as shown in (Fig. 8.5-2), this function makes the input change slow as shown in (Fig. 8.5-3).</p> <p>T (PV filter time constant) is the time when input change reaches 63% of the desired PV.</p> <div style="text-align: center;">  <p>(Fig. 8.5-2)</p> </div> <div style="text-align: center;">  <p>(Fig. 8.5-3)</p> </div> <ul style="list-style-type: none"> <li>• Setting range: 0.0 to 10.0 seconds</li> </ul>										
C5L 0 noL	<p><b>Communication protocol</b></p> <ul style="list-style-type: none"> <li>• Selects communication protocol.</li> <li>• Selection item:</li> </ul> <table border="1" data-bbox="459 1541 1481 1749"> <tbody> <tr> <td>noL</td> <td>Shinko protocol</td> </tr> <tr> <td>SbL</td> <td>SV digital transmission (Shinko protocol)</td> </tr> <tr> <td>Sbr</td> <td>SV digital reception (Shinko protocol)</td> </tr> <tr> <td>noA</td> <td>Modbus ASCII mode</td> </tr> <tr> <td>noR</td> <td>Modbus RTU mode</td> </tr> </tbody> </table> <p>Available when C5W or C5 option is ordered.</p>	noL	Shinko protocol	SbL	SV digital transmission (Shinko protocol)	Sbr	SV digital reception (Shinko protocol)	noA	Modbus ASCII mode	noR	Modbus RTU mode
noL	Shinko protocol										
SbL	SV digital transmission (Shinko protocol)										
Sbr	SV digital reception (Shinko protocol)										
noA	Modbus ASCII mode										
noR	Modbus RTU mode										
C5O 0 0000	<p><b>Instrument number</b></p> <ul style="list-style-type: none"> <li>• Sets the instrument number.</li> </ul> <p>The instrument numbers should be set one by one when multiple instruments are connected in Serial communication, otherwise communication is impossible.</p> <ul style="list-style-type: none"> <li>• Setting range: 0 to 95</li> </ul> <p>Available when C5W or C5 option is ordered.</p>										

Characters, Factory Default	Setting Item, Function, Setting Range												
<b>C5P</b> 0 0096	<b>Communication speed</b> • Selects a communication speed equal to that of the host computer. • Selection item:												
	<table border="1"> <tr> <td>0096</td> <td>9600 bps</td> </tr> <tr> <td>0192</td> <td>19200 bps</td> </tr> <tr> <td>0384</td> <td>38400 bps</td> </tr> </table>	0096	9600 bps	0192	19200 bps	0384	38400 bps						
	0096	9600 bps											
	0192	19200 bps											
0384	38400 bps												
Available when C5W or C5 option is ordered.													
<b>C5P</b> 0 7E8n	<b>Data bit/Parity</b> • Selects data bit and parity equal to those of the host computer. • Selection item:												
	<table border="1"> <tr> <td>8non</td> <td>8 bits/No parity</td> </tr> <tr> <td>7non</td> <td>7 bits/No parity</td> </tr> <tr> <td>8E8n</td> <td>8 bits/Even</td> </tr> <tr> <td>7E8n</td> <td>7 bits/Even</td> </tr> <tr> <td>8odd</td> <td>8 bits/Odd</td> </tr> <tr> <td>7odd</td> <td>7 bits/Odd</td> </tr> </table>	8non	8 bits/No parity	7non	7 bits/No parity	8E8n	8 bits/Even	7E8n	7 bits/Even	8odd	8 bits/Odd	7odd	7 bits/Odd
	8non	8 bits/No parity											
	7non	7 bits/No parity											
	8E8n	8 bits/Even											
	7E8n	7 bits/Even											
	8odd	8 bits/Odd											
7odd	7 bits/Odd												
Available when C5W or C5 option is ordered.													
<b>C5P</b> 0 0001	<b>Stop bit</b> • Selects the stop bit equal to that of the host computer. • Selection item:												
	<table border="1"> <tr> <td>0001</td> <td>1 bit</td> </tr> <tr> <td>0002</td> <td>2 bits</td> </tr> </table>	0001	1 bit	0002	2 bits								
	0001	1 bit											
0002	2 bits												
Available when C5W or C5 option is ordered.													
<b>C5D</b> 0 0010	<b>Response delay time</b> • Response from the controller can be delayed after receiving command from the host computer. If Response delay time is changed via software communication, the changed delay time will be reflected from that response data. • Setting range: 0 to 1000 ms Available when C5W or C5 option is ordered.												
<b>SV_b</b> 0 0000	<b>SVTC bias</b> • SV adds SVTC bias value to the value received by the SVTC command. • Setting range: $\pm 20\%$ of input span DC voltage, current inputs: $\pm 20\%$ of scaling span (The placement of the decimal point follows the selection.) Available when C5W, C5 option is ordered, and when <b>SV_r</b> [Set value digital reception (Shinko protocol)] is selected in [Communication protocol].												

At this stage, settings for Engineering setting mode 1 are complete.

Press the **RST** key. The unit reverts to RUN mode.

## 8.6 Setting Items in Engineering Setting Mode 2

In Engineering setting mode 2, the following setting items can be set:











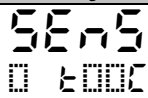
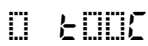











Input type, Scaling high limit, Scaling low limit, Event output EV□ allocation, Step time unit, Power restore action, etc.

Setting data is common to all patterns.

### • How to enter Engineering setting mode 2

In RUN mode, press the ,  and **MODE** key (in that order) together for approx. 3 seconds to enter Engineering setting mode 2.

Setting items in Engineering setting mode 2 are shown below.

Characters, Factory Default	Setting Item, Function, Setting Range		
 	<b>Input type</b>		
	<ul style="list-style-type: none"> <li>• Selects an input type from thermocouple (10 types), RTD (2 types), direct current (2 types) and DC voltage (4 type), and the unit °C/°F.</li> <li>• <b>When changing the input from DC voltage to other inputs, remove the sensor connected to this controller first, then change the input. If the input is changed with the sensor connected, the input circuit may break.</b></li> <li>• When changing an input type, refer to Section “9.6 Items to be Initialized by Changing Settings” (p.104).</li> <li>• Selection item:</li> </ul>		
		K	-200 to 1370 °C
		K	-200.0 to 400.0 °C
		J	-200 to 1000 °C
		R	0 to 1760 °C
		S	0 to 1760 °C
		B	0 to 1820 °C
		E	-200 to 800 °C
		T	-200.0 to 400.0 °C
		N	-200 to 1300 °C
		PL-II	0 to 1390 °C
		C(W/Re5-26)	0 to 2315 °C
		Pt100	-200.0 to 850.0 °C
		JPt100	-200.0 to 500.0 °C
		Pt100	-200 to 850 °C
		JPt100	-200 to 500 °C
		K	-328 to 2498 °F
		K	-328.0 to 752.0 °F
		J	-328 to 1832 °F
	R	32 to 3200 °F	
	S	32 to 3200 °F	
	B	32 to 3308 °F	
	E	-328 to 1472 °F	

Characters, Factory Default	Setting Item, Function, Setting Range													
FD F 0 0000	T	-328.0 to 752.0 °F												
n00F	N	-328 to 2372 °F												
PL2F	PL-II	32 to 2534 °F												
c00F	C(W/Re5-26)	32 to 4199 °F												
PF F	Pt100	-328.0 to 1562.0 °F												
JPTF	JPt100	-328.0 to 932.0 °F												
P00F	Pt100	-328 to 1562 °F												
JPTF	JPt100	-328 to 932 °F												
420A	4 - 20 mA	-2000 to 10000												
020A	0 - 20 mA	-2000 to 10000												
00 1V	0 - 1 V	-2000 to 10000												
005V	0 - 5 V	-2000 to 10000												
105V	1 - 5 V	-2000 to 10000												
0 10V	0 - 10 V	-2000 to 10000												
SFLH 0 1370	<b>Scaling high limit</b> <ul style="list-style-type: none"> <li>• Sets scaling high limit value.</li> <li>• Setting range: Scaling low limit to Input range high limit DC voltage, current inputs: -2000 to 10000 (The placement of the decimal point follows the selection.)</li> </ul>													
SFL L 0 -200	<b>Scaling low limit</b> <ul style="list-style-type: none"> <li>• Sets scaling low limit value.</li> <li>• Setting range: Input range low limit to Scaling high limit DC voltage, current inputs: -2000 to 10000 (The placement of the decimal point follows the selection.)</li> </ul>													
dP00 0 0000	<b>Decimal point place</b> <ul style="list-style-type: none"> <li>• Selects decimal point place.</li> <li>• Selection item:</li> </ul> <table border="1"> <tr> <td>0000</td> <td>No decimal point</td> </tr> <tr> <td>0000</td> <td>1 digit after decimal point</td> </tr> <tr> <td>0000</td> <td>2 digits after decimal point</td> </tr> <tr> <td>0000</td> <td>3 digits after decimal point</td> </tr> </table> <p>Available when DC voltage or current input is selected in [Input type].</p>		0000	No decimal point	0000	1 digit after decimal point	0000	2 digits after decimal point	0000	3 digits after decimal point				
0000	No decimal point													
0000	1 digit after decimal point													
0000	2 digits after decimal point													
0000	3 digits after decimal point													
EV0 1 0 0000	<b>Event output EV1 allocation</b> <ul style="list-style-type: none"> <li>• Selects Event output EV1 from the table below.</li> <li>• When changing Event output EV1, refer to Section “9.6 Items to be Initialized by Changing Settings” (p.104).</li> <li>• Selection item:</li> </ul> <table border="1"> <tr> <td>0000</td> <td>No event</td> </tr> <tr> <td>000 1</td> <td>Alarm output, High limit alarm</td> </tr> <tr> <td>000 2</td> <td>Alarm output, Low limit alarm</td> </tr> <tr> <td>000 3</td> <td>Alarm output, High/Low limits alarm</td> </tr> <tr> <td>000 4</td> <td>Alarm output, High/Low limits independent alarm</td> </tr> <tr> <td>000 5</td> <td>Alarm output, High/Low limit range alarm</td> </tr> </table>		0000	No event	000 1	Alarm output, High limit alarm	000 2	Alarm output, Low limit alarm	000 3	Alarm output, High/Low limits alarm	000 4	Alarm output, High/Low limits independent alarm	000 5	Alarm output, High/Low limit range alarm
0000	No event													
000 1	Alarm output, High limit alarm													
000 2	Alarm output, Low limit alarm													
000 3	Alarm output, High/Low limits alarm													
000 4	Alarm output, High/Low limits independent alarm													
000 5	Alarm output, High/Low limit range alarm													



Characters, Factory Default	Setting Item, Function, Setting Range	
	0006	Alarm output, High/Low limit range independent alarm
	0007	Alarm output, Process high alarm
	0008	Alarm output, Process low alarm
	0009	Alarm output, High limit with standby alarm
	0010	Alarm output, Low limit with standby alarm
	0011	Alarm output, High/Low limits with standby alarm
	0012	Alarm output, High/Low limits with standby independent alarm
	0013	<p>Heater burnout alarm output (When C5W, EIW or W option is ordered):</p> <p>Detects load current value with CT (current transformer), and if it is lower than heater burnout alarm value, Heater burnout alarm output is turned ON.</p>
	0014	<p>Loop break alarm output:</p> <p>Loop break alarm time and Loop break alarm span are set.</p> <p>If the PV does not reach the span setting within the time allotted to assess the Loop break alarm (after the MV has reached 100% or the OUT high limit value), the alarm output is turned ON.</p> <p>If the PV does not drop to the span setting within the time allotted to assess the Loop break alarm (after the MV has reached 0% or the OUT low limit value), the alarm output is turned ON.</p>
	0015	<p>Time signal output:</p> <p>Turns ON during program control RUN, by setting Time signal output OFF time and ON time within total time in one pattern.</p>
	0016	<p>Output during AT:</p> <p>Turns ON during AT.</p>
	0017	<p>Pattern end output:</p> <p>Turns ON when Program control ends, and remains ON during the time set in [Pattern end output time].</p>
	0018	<p>Output by communication command:</p> <p>Communication command 8004 B0 EV1 output 0: OFF, 1: ON  B1 EV2 output 0: OFF, 1: ON  B2 EV3 output 0: OFF, 1: ON</p>
	0019	<p>RUN output:</p> <p>Turns ON during program control RUN.</p>
	<p>When 0001 (High limit alarm) to 0012 (High/Low limit with standby independent alarm) or 0015 (Time signal output) is selected, one output can be set to one event output.</p> <p>When 0013 (Heater burnout alarm output), 0014 (Loop break alarm), 0016 (Output during AT) to 0019 (RUN output) are selected, each output is common to multiple event outputs.</p>	
<p><b>A 13A</b>  0 0000</p>	<p><b>EV1 alarm value 0 Enabled/Disabled</b></p> <ul style="list-style-type: none"> <li>• When EV1 alarm value is 0 (zero), alarm action can be Enabled or Disabled.</li> <li>• Selection item:</li> </ul>	
	0000	Disabled
	YES0	Enabled
	<p>Available when any alarm from 0001 (High limit alarm) to 0012 (High/Low limits with standby independent alarm) is selected in [Event output EV1 allocation] - excluding 0007 (Process high alarm) and 0008 (Process low alarm).</p>	

Characters, Factory Default	Setting Item, Function, Setting Range				
A 144 0 000	<p><b>EV1 alarm hysteresis</b></p> <ul style="list-style-type: none"> <li>• Sets EV1 alarm hysteresis.</li> <li>• Setting range: 0.1 to 1000.0°C (°F), DC voltage, current inputs: 1 to 10000 (The placement of the decimal point follows the selection.)</li> </ul> <p>Available when any alarm from 000 1 (High limit alarm) to 00 12 (High/Low limits with standby independent alarm) is selected in [Event output EV1 allocation].</p>				
A 124 0 0000	<p><b>EV1 alarm delay time</b></p> <ul style="list-style-type: none"> <li>• Sets EV1 alarm action delay time.</li> </ul> <p>When setting time has elapsed after PV enters the alarm output range, the alarm is activated.</p> <ul style="list-style-type: none"> <li>• Setting range: 0 to 10000 seconds</li> </ul> <p>Available when any alarm from 000 1 (High limit alarm) to 00 12 (High/Low limits with standby independent alarm) is selected in [Event output EV1 allocation].</p>				
A 12A 0 noNL	<p><b>EV1 alarm Energized/De-energized</b></p> <ul style="list-style-type: none"> <li>• Selects Energized/De-energized status for EV1 alarm.</li> </ul> <p>When Energized is selected, and Event output 1 is conductive (ON) while the EV1 indicator is lit. Event output 1 is not conductive (OFF) while the EV1 indicator is not lit.</p> <p>When De-energized is selected, Event output 1 not conductive (OFF) while the EV1 indicator is lit. Event output 1 is conductive (ON) while the EV1 indicator is not lit.</p> <div style="display: flex; justify-content: space-around;"> <div data-bbox="494 1142 877 1478"> <p><b>High limit alarm (Energized)</b></p> <p style="text-align: center;">(Fig. 8.6-1)</p> </div> <div data-bbox="957 1142 1340 1478"> <p><b>High limit alarm (De-energized)</b></p> <p style="text-align: center;">(Fig. 8.6-2)</p> </div> </div> <ul style="list-style-type: none"> <li>• Selection item:</li> </ul> <table border="1" style="width: 100%; border-collapse: collapse;"> <tr> <td style="width: 30%; text-align: center;">noNL</td> <td>Energized</td> </tr> <tr> <td style="text-align: center;">rEES</td> <td>De-energized</td> </tr> </table>	noNL	Energized	rEES	De-energized
noNL	Energized				
rEES	De-energized				
EV02 0 0000	<p><b>Event output EV2 allocation</b></p> <ul style="list-style-type: none"> <li>• Selects Event output EV2 from the table below.</li> <li>• When changing Event output EV2, refer to Section “9.6 Items to be Initialized by Changing Settings” (p.104).</li> <li>• Selection item:</li> </ul> <table border="1" style="width: 100%; border-collapse: collapse;"> <tr> <td style="width: 30%; text-align: center;">0000</td> <td>No event</td> </tr> <tr> <td style="text-align: center;">000 1</td> <td>Alarm output, High limit alarm</td> </tr> </table> <p>Available when any alarm from 000 1 (High limit alarm) to 00 12 (High/Low limits with standby independent alarm) is selected in [Event output EV1 allocation].</p>	0000	No event	000 1	Alarm output, High limit alarm
0000	No event				
000 1	Alarm output, High limit alarm				

Characters, Factory Default	Setting Item, Function, Setting Range
0002	Alarm output, Low limit alarm
0003	Alarm output, High/Low limits alarm
0004	Alarm output, High/Low limits independent alarm
0005	Alarm output, High/Low limit range alarm
0006	Alarm output, High/Low limit range independent alarm
0007	Alarm output, Process high alarm
0008	Alarm output, Process low alarm
0009	Alarm output, High limit with standby alarm
0010	Alarm output, Low limit with standby alarm
0011	Alarm output, High/Low limits with standby alarm
0012	Alarm output, High/Low limits with standby independent alarm
0013	Heater burnout alarm output (When C5W, EIW or W option is ordered): Detects load current value with CT (current transformer), and if it is lower than heater burnout alarm value, Heater burnout alarm output is turned ON.
0014	Loop break alarm output: Loop break alarm time and Loop break alarm span are set. If the PV does not reach the span setting within the time allotted to assess the Loop break alarm (after the MV has reached 100% or the OUT high limit value), the alarm output is turned ON. If the PV does not drop to the span setting within the time allotted to assess the Loop break alarm (after the MV has reached 0% or the OUT low limit value), the alarm output is turned ON.
0015	Time signal output: Turns ON during program control RUN, by setting Time signal output OFF time and ON time within total time in one pattern.
0016	Output during AT: Turns ON during AT.
0017	Pattern end output: Turns ON when Program control ends, and remains ON during the time set in [Pattern end output time].
0018	Output by communication command: Communication command 8004 B0 EV1 output 0: OFF, 1: ON B1 EV2 output 0: OFF, 1: ON B2 EV3 output 0: OFF, 1: ON
0019	RUN output Turns ON during program control RUN.
0020	Heating/Cooling control Relay contact output Works as Heating/Cooling control output OUT2.
<p>When 0001 (High limit alarm) to 0012 (High/Low limit with standby independent alarm) or 0015 (Time signal output) is selected, one output can be set to one event output.</p> <p>When 0013 (Heater burnout alarm output), 0014 (Loop break alarm), 0016 (Output during AT) to 0019 (RUN output) are selected, each output is common to multiple event outputs.</p> <p>Available when the EV2 or EV3(DR) option is ordered.</p>	

Characters, Factory Default	Setting Item, Function, Setting Range				
<b>A2EA</b> 0 0000	<p><b>EV2 alarm value 0 Enabled/Disabled</b></p> <ul style="list-style-type: none"> <li>When EV2 alarm value is 0 (zero), alarm action can be Enabled or Disabled.</li> <li>Selection item:</li> </ul> <table border="1" data-bbox="478 353 734 436"> <tr> <td>no00</td> <td>Disabled</td> </tr> <tr> <td>YES0</td> <td>Enabled</td> </tr> </table> <p>Available when any alarm from 00 0 1 (High limit alarm) to 00 12 (High/Low limits with standby independent alarm) is selected in [Event output EV2 allocation] - excluding 0007 (Process high alarm) and 0008 (Process low alarm).</p>	no00	Disabled	YES0	Enabled
no00	Disabled				
YES0	Enabled				
<b>A2HY</b> 0 00 0	<p><b>EV2 alarm hysteresis</b></p> <ul style="list-style-type: none"> <li>Sets EV2 alarm hysteresis.</li> <li>Setting range: 0.1 to 1000.0°C (°F), DC voltage, current inputs: 1 to 10000 (The placement of the decimal point follows the selection.)</li> </ul> <p>Available when any alarm from 000 1 (High limit alarm) to 00 12 (High/Low limits with standby independent alarm) is selected in [Event output EV2 allocation].</p>				
<b>A2DY</b> 0 0000	<p><b>EV2 alarm delay time</b></p> <ul style="list-style-type: none"> <li>Sets EV2 alarm action delay time.</li> <li>When setting time has elapsed after PV enters the alarm output range, the alarm is activated.</li> <li>Setting range: 0 to 10000 seconds</li> </ul> <p>Available when any alarm from 000 1 (High limit alarm) to 00 12 (High/Low limits with standby independent alarm) is selected in [Event output EV2 allocation].</p>				
<b>A2LA</b> 0 no0L	<p><b>EV2 alarm Energized/De-energized</b></p> <ul style="list-style-type: none"> <li>Selects Energized/De-energized status for EV2 alarm.</li> <li>When Energized is selected, and Event output 2 is conductive (ON) while the EV2 indicator is lit. Event output 2 is not conductive (OFF) while the EV2 indicator is not lit.</li> <li>When De-energized is selected, Event output 2 not conductive (OFF) while the EV2 indicator is lit. Event output 2 is conductive (ON) while the EV2 indicator is not lit.</li> </ul> <div style="display: flex; justify-content: space-around;"> <div data-bbox="494 1456 877 1836"> <p><b>High limit alarm (Energized)</b></p> <p>(Fig. 8.6-3)</p> </div> <div data-bbox="957 1456 1340 1836"> <p><b>High limit alarm (De-energized)</b></p> <p>(Fig. 8.6-4)</p> </div> </div> <ul style="list-style-type: none"> <li>Selection item:</li> </ul> <table border="1" data-bbox="478 1915 790 2004"> <tr> <td>no0L</td> <td>Energized</td> </tr> <tr> <td>rE0S</td> <td>De-energized</td> </tr> </table> <p>Available when any alarm from 000 1 (High limit alarm) to 00 12 (High/Low limits with standby independent alarm) is selected in [Event output EV2 allocation].</p>	no0L	Energized	rE0S	De-energized
no0L	Energized				
rE0S	De-energized				



Characters, Factory Default	Setting Item, Function, Setting Range				
	<p>When 0001 (High limit alarm) to 0012 (High/Low limit with standby independent alarm) or 0015 (Time signal output) is selected, one output can be set to one event output. When 0013 (Heater burnout alarm output), 0014 (Loop break alarm), 0015 (Output during AT) to 0019 (RUN output) are selected, each output is common to multiple event outputs.</p> <p>Available when the EV3D□ or EI option is ordered.</p>				
<p>A3EA 0 no00</p>	<p><b>EV3 alarm value 0 Enabled/Disabled</b></p> <ul style="list-style-type: none"> <li>When EV3 alarm value is 0 (zero), alarm action can be Enabled or Disabled.</li> <li>Selection item:</li> </ul> <table border="1" data-bbox="454 577 734 667"> <tr> <td>no00</td> <td>Disabled</td> </tr> <tr> <td>YES0</td> <td>Enabled</td> </tr> </table> <p>Available when any alarm from 0001 (High limit alarm) to 0012 (High/Low limits with standby independent alarm) is selected in [Event output EV3 allocation] - excluding 0007 (Process high alarm) and 0008 (Process low alarm).</p>	no00	Disabled	YES0	Enabled
no00	Disabled				
YES0	Enabled				
<p>A3HY 0 000</p>	<p><b>EV3 alarm hysteresis</b></p> <ul style="list-style-type: none"> <li>Sets EV3 alarm hysteresis.</li> <li>Setting range: 0.1 to 1000.0°C (°F), DC voltage, current inputs: 1 to 10000 (The placement of the decimal point follows the selection.)</li> </ul> <p>Available when any alarm from 0001 (High limit alarm) to 0012 (High/Low limits with standby independent alarm) is selected in [Event output EV3 allocation].</p>				
<p>A3DY 0 0000</p>	<p><b>EV3 alarm delay time</b></p> <ul style="list-style-type: none"> <li>Sets EV3 alarm action delay time.</li> <li>When setting time has elapsed after PV enters the alarm output range, the alarm is activated.</li> <li>Setting range: 0 to 10000 seconds</li> </ul> <p>Available when any alarm from 0001 (High limit alarm) to 0012 (High/Low limits with standby independent alarm) is selected in [Event output EV3 allocation].</p>				
<p>A3LA 0 no0L</p>	<p><b>EV3 alarm Energized/De-energized</b></p> <ul style="list-style-type: none"> <li>Selects Energized/De-energized status for EV3 alarm.</li> <li>When Energized is selected, and Event output 3 is conductive (ON) while the EV3 indicator is lit. Event output 3 is not conductive (OFF) while the EV3 indicator is not lit.</li> <li>When De-energized is selected, Event output 3 not conductive (OFF) while the EV3 indicator is lit. Event output 3 is conductive (ON) while the EV3 indicator is not lit.</li> </ul> <div style="display: flex; justify-content: space-around;"> <div data-bbox="494 1691 877 2072"> <p><b>High limit alarm (Energized)</b></p> <p>(Fig. 8.6-5)</p> </div> <div data-bbox="957 1691 1340 2072"> <p><b>High limit alarm (De-energized)</b></p> <p>(Fig. 8.6-6)</p> </div> </div>				

Characters, Factory Default	Setting Item, Function, Setting Range																																																										
	<ul style="list-style-type: none"> <li>Selection item</li> </ul>																																																										
	noNL	Energized																																																									
	rEBS	De-energized																																																									
	Available when any alarm from 0001 (High limit alarm) to 0012 (High/Low limits with standby independent alarm) is selected in [Event output EV3 allocation].																																																										
<b>EV 1</b> 0 0000	<b>Event input DI1 allocation</b> <ul style="list-style-type: none"> <li>Selects Event input DI1 from the table below.</li> <li>Selection item:</li> </ul> <table border="1" style="width: 100%; border-collapse: collapse;"> <thead> <tr> <th style="width: 10%;"></th> <th style="width: 60%;">Event input function</th> <th style="width: 15%;">Input ON (Closed)</th> <th style="width: 15%;">Input OFF (Open)</th> </tr> </thead> <tbody> <tr> <td style="text-align: center;">0000</td> <td>No event</td> <td></td> <td></td> </tr> <tr> <td style="text-align: center;">0001</td> <td>Pattern number selection</td> <td colspan="2">Refer to "About Event input".</td> </tr> <tr> <td style="text-align: center;">0002</td> <td>Direct/Reverse action</td> <td>Direct action</td> <td>Reverse action</td> </tr> <tr> <td style="text-align: center;">0003</td> <td>Program control RUN/STOP</td> <td>RUN</td> <td>STOP</td> </tr> <tr> <td style="text-align: center;">0004</td> <td>Program control Holding/Not holding</td> <td>Holding</td> <td>Not holding</td> </tr> <tr> <td style="text-align: center;">0005</td> <td>Program control Advance function</td> <td>Advance function</td> <td>Usual control</td> </tr> </tbody> </table> <p>Available when C5W, EIW, EIT, C5 or EI option is ordered.</p> <ul style="list-style-type: none"> <li><b>About Event input:</b> Signal edge action from OFF to ON / ON to OFF is engaged. However, when power is turned ON, level action is engaged except 0005 (Program control Advance function). If 0001 (Pattern number selection) is selected in [Event input DI1, DI2 allocation], OR calculation [if any one is ON (Closed), the function activates] begins. An action changed by Event input DI□ has priority. If 0001 (Pattern number selection) is selected, Patterns 1 to 4 can be selected by ON (Closed) or OFF (Open) status of Event input DI1 and DI2. Pattern numbers selected by Event input have priority over pattern numbers selected by keypad operation. To select pattern numbers by keypad operation, make sure all Event inputs are in OFF (Open) status.</li> </ul> <p><b>When 0001 (Pattern number selection) is selected only in [Event input DI1 allocation]</b></p> <table border="1" style="width: 100%; border-collapse: collapse;"> <thead> <tr> <th style="width: 30%;">Pattern number</th> <th style="width: 35%;">*</th> <th style="width: 35%;">2</th> </tr> </thead> <tbody> <tr> <td>Event input DI1</td> <td>OFF(Open)</td> <td>ON(Closed)</td> </tr> </tbody> </table> <p>* This number will be selected by keypad.</p> <p><b>When 0001 (Pattern number selection) is selected only in [Event input DI2 allocation]</b></p> <table border="1" style="width: 100%; border-collapse: collapse;"> <thead> <tr> <th style="width: 30%;">Pattern number</th> <th style="width: 35%;">*</th> <th style="width: 35%;">2</th> </tr> </thead> <tbody> <tr> <td>Event input DI2</td> <td>OFF(Open)</td> <td>ON(Closed)</td> </tr> </tbody> </table> <p>* This number will be selected by keypad.</p> <p><b>When 0001 (Pattern number selection) is selected in [Event input DI1, DI2 allocation]</b></p> <table border="1" style="width: 100%; border-collapse: collapse;"> <thead> <tr> <th style="width: 20%;">Pattern number</th> <th style="width: 15%;">*</th> <th style="width: 15%;">2</th> <th style="width: 15%;">3</th> <th style="width: 15%;">4</th> </tr> </thead> <tbody> <tr> <td>Event input DI1</td> <td>OFF(Open)</td> <td>ON(Closed)</td> <td>OFF(Open)</td> <td>ON(Closed)</td> </tr> <tr> <td>Event input DI2</td> <td>OFF(Open)</td> <td>OFF(Open)</td> <td>ON(Closed)</td> <td>ON(Closed)</td> </tr> </tbody> </table> <p>* This number will be selected by keypad.</p>					Event input function	Input ON (Closed)	Input OFF (Open)	0000	No event			0001	Pattern number selection	Refer to "About Event input".		0002	Direct/Reverse action	Direct action	Reverse action	0003	Program control RUN/STOP	RUN	STOP	0004	Program control Holding/Not holding	Holding	Not holding	0005	Program control Advance function	Advance function	Usual control	Pattern number	*	2	Event input DI1	OFF(Open)	ON(Closed)	Pattern number	*	2	Event input DI2	OFF(Open)	ON(Closed)	Pattern number	*	2	3	4	Event input DI1	OFF(Open)	ON(Closed)	OFF(Open)	ON(Closed)	Event input DI2	OFF(Open)	OFF(Open)	ON(Closed)	ON(Closed)
	Event input function	Input ON (Closed)	Input OFF (Open)																																																								
0000	No event																																																										
0001	Pattern number selection	Refer to "About Event input".																																																									
0002	Direct/Reverse action	Direct action	Reverse action																																																								
0003	Program control RUN/STOP	RUN	STOP																																																								
0004	Program control Holding/Not holding	Holding	Not holding																																																								
0005	Program control Advance function	Advance function	Usual control																																																								
Pattern number	*	2																																																									
Event input DI1	OFF(Open)	ON(Closed)																																																									
Pattern number	*	2																																																									
Event input DI2	OFF(Open)	ON(Closed)																																																									
Pattern number	*	2	3	4																																																							
Event input DI1	OFF(Open)	ON(Closed)	OFF(Open)	ON(Closed)																																																							
Event input DI2	OFF(Open)	OFF(Open)	ON(Closed)	ON(Closed)																																																							

Characters, Factory Default	Setting Item, Function, Setting Range																														
<b>EI 2</b> 0 0000	<b>Event input DI2 allocation</b> <ul style="list-style-type: none"> <li>• Selects Event input DI2 from the table below.</li> <li>• Selection item:</li> </ul>																														
	<b>Event input function</b>	<b>Input ON (Closed)</b>	<b>Input OFF (Open)</b>																												
0000	No event																														
0001	Pattern number selection	Refer to “About Event input”.																													
0002	Direct/Reverse action	Direct action	Reverse action																												
0003	Program control RUN/STOP	RUN	STOP																												
0004	Program control Holding/Not holding	Holding	Not holding																												
0005	Program control Advance function	Advance function	Usual control																												
Available when C5W, EIW, EIT, C5 or EI option is ordered.																															
<ul style="list-style-type: none"> <li>• <b>About Event input:</b> Signal edge action from OFF to ON / ON to OFF is engaged. However, when power is turned ON, level action is engaged except 0005 (Program control Advance function). If 0001 (Pattern number selection) is selected in [Event input DI1, DI2 allocation], OR calculation [if any one is ON (closed), the function activates] begins. An action changed by Event input DI□ has priority. If 0001 (Pattern number selection) is selected, Patterns 1 to 4 can be selected by ON (Closed) or OFF (Open) status of Event input DI1 and DI2. Pattern numbers selected by Event input have priority over pattern numbers selected by keypad operation. To select pattern numbers by keypad, make sure all Event inputs are in OFF (Open) status.</li> </ul> <p><b>When 0001 (Pattern number selection) is selected only in [Event input DI1 allocation]</b></p> <table border="1" style="margin-left: auto; margin-right: auto;"> <thead> <tr> <th style="text-align: left;">Pattern number</th> <th style="text-align: center;">*</th> <th style="text-align: center;">2</th> </tr> </thead> <tbody> <tr> <td>Event input DI1</td> <td>OFF(Open)</td> <td>ON(Closed)</td> </tr> </tbody> </table> <p style="text-align: center;">* This number will be selected by keypad.</p> <p><b>When 0001 (Pattern number selection) is selected only in [Event input DI2 allocation]</b></p> <table border="1" style="margin-left: auto; margin-right: auto;"> <thead> <tr> <th style="text-align: left;">Pattern number</th> <th style="text-align: center;">*</th> <th style="text-align: center;">2</th> </tr> </thead> <tbody> <tr> <td>Event input DI2</td> <td>OFF(Open)</td> <td>ON(Closed)</td> </tr> </tbody> </table> <p style="text-align: center;">* This number will be selected by keypad.</p> <p><b>When 0001 (Pattern number selection) is selected in [Event input DI1, DI2 allocation]</b></p> <table border="1" style="margin-left: auto; margin-right: auto;"> <thead> <tr> <th style="text-align: left;">Pattern number</th> <th style="text-align: center;">*</th> <th style="text-align: center;">2</th> <th style="text-align: center;">3</th> <th style="text-align: center;">4</th> </tr> </thead> <tbody> <tr> <td>Event input DI1</td> <td>OFF(Open)</td> <td>ON(Closed)</td> <td>OFF(Open)</td> <td>ON(Closed)</td> </tr> <tr> <td>Event input DI2</td> <td>OFF(Open)</td> <td>OFF(Open)</td> <td>ON(Closed)</td> <td>ON(Closed)</td> </tr> </tbody> </table> <p style="text-align: center;">* This number will be selected by keypad.</p>					Pattern number	*	2	Event input DI1	OFF(Open)	ON(Closed)	Pattern number	*	2	Event input DI2	OFF(Open)	ON(Closed)	Pattern number	*	2	3	4	Event input DI1	OFF(Open)	ON(Closed)	OFF(Open)	ON(Closed)	Event input DI2	OFF(Open)	OFF(Open)	ON(Closed)	ON(Closed)
Pattern number	*	2																													
Event input DI1	OFF(Open)	ON(Closed)																													
Pattern number	*	2																													
Event input DI2	OFF(Open)	ON(Closed)																													
Pattern number	*	2	3	4																											
Event input DI1	OFF(Open)	ON(Closed)	OFF(Open)	ON(Closed)																											
Event input DI2	OFF(Open)	OFF(Open)	ON(Closed)	ON(Closed)																											

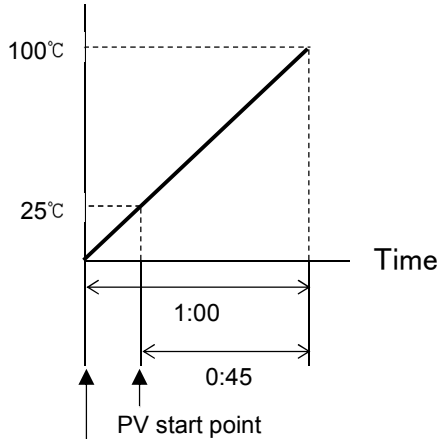

Characters, Factory Default	Setting Item, Function, Setting Range						
T-05 0 P800	<p><b>Transmission output type</b></p> <ul style="list-style-type: none"> <li>• Selects the transmission output type. Converting the value (PV, SV, MV transmission) to analog signal every 125 ms, outputs the value in current or voltage.</li> <li>• When changing transmission output type, refer to Section “9.6 Items to be Initialized by Changing Settings” (p.104).</li> <li>• Selection item:</li> </ul> <table border="1" data-bbox="459 524 1481 645"> <tr> <td>P800</td> <td>PV transmission</td> </tr> <tr> <td>S800</td> <td>SV transmission</td> </tr> <tr> <td>M800</td> <td>MV transmission</td> </tr> </table> <p>Available when EIT option is ordered.</p>	P800	PV transmission	S800	SV transmission	M800	MV transmission
P800	PV transmission						
S800	SV transmission						
M800	MV transmission						
T-LH 0 1370	<p><b>Transmission output high limit</b></p> <ul style="list-style-type: none"> <li>• Sets the Transmission output high limit value. (This value corresponds to 20 mA in direct current output.) Outputs Transmission output low limit value if Transmission output high limit and low limit value are the same. If SV or MV transmission is selected, outputs 4 mA at the time of Program control STOP (in Standby).</li> <li>• Setting range: PV, SV transmission: Transmission output low limit to Input range high limit Direct current, voltage input: -2000 to 10000 (The placement of the decimal point follows the selection.) MV transmission: Transmission output low limit to 105.0%</li> </ul> <p>Available when EIT option is ordered.</p>						
T-LL 0 -200	<p><b>Transmission output low limit</b></p> <ul style="list-style-type: none"> <li>• Sets the Transmission output low limit value. (This value corresponds to 4 mA in direct current output.) Outputs Transmission output low limit value if Transmission output high limit and low limit value are the same. If SV or MV transmission is selected, 4 mA is output while in Program control STOP (in Standby).</li> <li>• Setting range: PV, SV transmission: Input range low limit to Transmission output high limit Direct current, voltage input: -2000 to 10000 (The placement of the decimal point follows the selection.) MV transmission: -5.0% to Transmission output high limit</li> </ul> <p>Available when EIT option is ordered.</p>						
A-50 0 0000	<p><b>Step time unit</b></p> <ul style="list-style-type: none"> <li>• Selects the Step time unit.</li> <li>• Selection item:</li> </ul> <table border="1" data-bbox="459 1872 1481 1951"> <tr> <td>0000</td> <td>Hours : Minutes</td> </tr> <tr> <td>SE00</td> <td>Minutes : Seconds</td> </tr> </table>	0000	Hours : Minutes	SE00	Minutes : Seconds		
0000	Hours : Minutes						
SE00	Minutes : Seconds						

Characters, Factory Default	Setting Item, Function, Setting Range						
P-ET 0 STOP	<p><b>Power restore action</b></p> <ul style="list-style-type: none"> <li>• Selects the program status if a power failure occurs mid-program, and it is restored.</li> <li>• Selection item:</li> </ul> <table border="1" data-bbox="459 394 1482 875"> <tr> <td data-bbox="459 394 608 517">STOP</td> <td data-bbox="608 394 1482 517">           Stops after power is restored.            After power is restored, stops current program control, and returns to the Program control STOP (in Standby).         </td> </tr> <tr> <td data-bbox="459 517 608 640">CONT</td> <td data-bbox="608 517 1482 640">           Continues (resumes) after power is restored.            Continues (resumes) previous program control after power is restored.         </td> </tr> <tr> <td data-bbox="459 640 608 875">HOLD</td> <td data-bbox="608 640 1482 875">           Suspends after power is restored.            After power is restored, suspends (on hold) current program, and performs control (Fixed value control) using the SV from the point of suspension.            Pressing the <span style="border: 1px solid black; padding: 2px;">RUN</span> key cancels suspension, and program control resumes.         </td> </tr> </table>	STOP	Stops after power is restored. After power is restored, stops current program control, and returns to the Program control STOP (in Standby).	CONT	Continues (resumes) after power is restored. Continues (resumes) previous program control after power is restored.	HOLD	Suspends after power is restored. After power is restored, suspends (on hold) current program, and performs control (Fixed value control) using the SV from the point of suspension. Pressing the <span style="border: 1px solid black; padding: 2px;">RUN</span> key cancels suspension, and program control resumes.
STOP	Stops after power is restored. After power is restored, stops current program control, and returns to the Program control STOP (in Standby).						
CONT	Continues (resumes) after power is restored. Continues (resumes) previous program control after power is restored.						
HOLD	Suspends after power is restored. After power is restored, suspends (on hold) current program, and performs control (Fixed value control) using the SV from the point of suspension. Pressing the <span style="border: 1px solid black; padding: 2px;">RUN</span> key cancels suspension, and program control resumes.						
5.54 0 0000	<p><b>Step SV when program control starts</b></p> <ul style="list-style-type: none"> <li>• Sets the step SV when Program control starts.</li> <li>• Setting range: Scaling low limit to Scaling high limit (The placement of the decimal point follows the selection.)</li> </ul>						
5.5L 0 P800	<p><b>Program control start type</b></p> <ul style="list-style-type: none"> <li>• Selects the Program control start type.</li> <li>• Selection item:</li> </ul> <p><b>PV start, PVR start</b></p>  <p>When Program control starts, the step SV is advanced to the PV, then Program control starts.</p> <p>(Fig. 8.6-7)</p>						

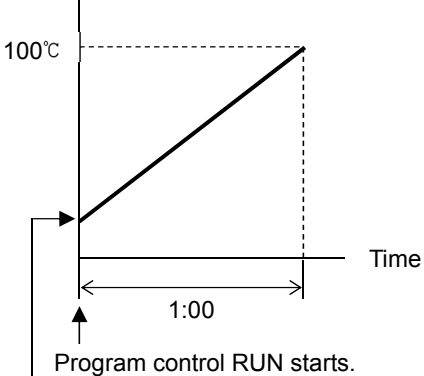
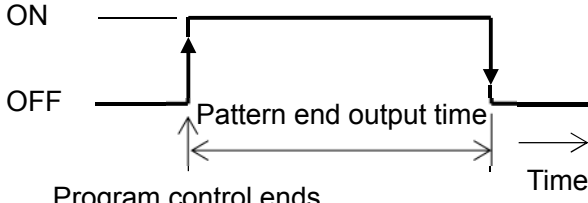
Characters, Factory Default	Setting Item, Function, Setting Range						
	<p><b>SV start</b></p>  <p>100°C</p> <p>Time</p> <p>1:00</p> <p>Program control RUN starts.</p> <p>Program control starts from the Step SV set in [Step SV when Program start starts].</p> <p>(Fig. 8.6-8)</p> <ul style="list-style-type: none"> <li>• Selection item:</li> </ul> <table border="1" data-bbox="454 840 1489 1234"> <tr> <td data-bbox="454 840 606 952"><b>P800</b></td> <td data-bbox="606 840 1489 952"> <p><b>PV start:</b></p> <p>Only when Program control starts, the step SV and step time are advanced to the PV, then Program control starts.</p> </td> </tr> <tr> <td data-bbox="454 952 606 1108"><b>P8r0</b></td> <td data-bbox="606 952 1489 1108"> <p><b>PVR start:</b></p> <p>When Program control starts and in pattern repeating, the step SV and step time are advanced to the PV, then the Program control starts.</p> </td> </tr> <tr> <td data-bbox="454 1108 606 1234"><b>S800</b></td> <td data-bbox="606 1108 1489 1234"> <p><b>SV start:</b></p> <p>When Program control starts, the Program control starts from the step SV set in [Step SV when program control starts].</p> </td> </tr> </table>	<b>P800</b>	<p><b>PV start:</b></p> <p>Only when Program control starts, the step SV and step time are advanced to the PV, then Program control starts.</p>	<b>P8r0</b>	<p><b>PVR start:</b></p> <p>When Program control starts and in pattern repeating, the step SV and step time are advanced to the PV, then the Program control starts.</p>	<b>S800</b>	<p><b>SV start:</b></p> <p>When Program control starts, the Program control starts from the step SV set in [Step SV when program control starts].</p>
<b>P800</b>	<p><b>PV start:</b></p> <p>Only when Program control starts, the step SV and step time are advanced to the PV, then Program control starts.</p>						
<b>P8r0</b>	<p><b>PVR start:</b></p> <p>When Program control starts and in pattern repeating, the step SV and step time are advanced to the PV, then the Program control starts.</p>						
<b>S800</b>	<p><b>SV start:</b></p> <p>When Program control starts, the Program control starts from the step SV set in [Step SV when program control starts].</p>						
<p><b>PENd</b> 0 0000</p>	<p><b>Pattern end output time</b></p> <ul style="list-style-type: none"> <li>• Sets Pattern end output retention time after program control is finished.</li> </ul> <p>If 'Pattern end output' is selected in [Event output EV□ allocation], pattern end output is turned ON after program control is finished, and the SV Display flashes <b>PENd</b>.</p> <p>Setting the time to 0 (zero) seconds causes continuous output, until the <b>STOP</b> key is pressed for 1 second, or until the power is turned OFF.</p> <p>By pressing the <b>STOP</b> key for 1 second, Pattern end output is turned OFF, and the unit returns to Program control STOP (in Standby).</p> <p>When setting the time to 1 to 10000 seconds: Pattern end output is automatically turned OFF after Pattern end output time has elapsed, and the unit returns to Program control STOP (in Standby).</p>  <p>ON</p> <p>OFF</p> <p>Pattern end output time</p> <p>Time</p> <p>Program control ends</p> <p>(Fig. 8.6-9)</p> <ul style="list-style-type: none"> <li>• Setting range: 0 to 10000 seconds</li> </ul>						

Characters, Factory Default	Setting Item, Function, Setting Range												
AT_b 0 0020	<p><b>AT bias</b></p> <ul style="list-style-type: none"> <li>Sets bias value for the AT.</li> <li>AT point is automatically determined by the deviation between PV and SV.</li> <li>AT bias setting works only in Fixed value control.</li> <li>Setting range: Thermocouple, RTD inputs without decimal point: 0 to 50°C (0 to 100°F) Thermocouple, RTD inputs with decimal point: 0.0 to 50.0°C (0.0 to 100.0°F)</li> <li>Available when Thermocouple or RTD input is selected in [Input type].</li> </ul>												
EoU 0 OFF0	<p><b>Output status when input errors occur</b></p> <ul style="list-style-type: none"> <li>Selects the output status when input errors (overscale, underscale) occur.</li> <li>Selection item:</li> </ul> <table border="1" style="width: 100%; border-collapse: collapse;"> <tr> <td style="text-align: center;">OFF0</td> <td style="text-align: left;">Output OFF</td> </tr> <tr> <td style="text-align: center;">ON00</td> <td style="text-align: left;">Output ON</td> </tr> </table> <p>Available for direct current and voltage inputs, and direct current output.</p>	OFF0	Output OFF	ON00	Output ON								
OFF0	Output OFF												
ON00	Output ON												
TAE 0 0000	<p><b>Indication time</b></p> <ul style="list-style-type: none"> <li>Sets time from no operation status until Displays are switched off.</li> <li>Displays relight by pressing any key while in Display sleep mode.</li> <li>When input errors (overscale, underscale) or burnout has occurred, Displays light up, and error codes are displayed.</li> <li>If errors are cancelled, Displays will turn off after indication time has passed again.</li> <li>Setting range: 00:00 to 60:00 (Minutes : Seconds)</li> <li>When set to 00:00, Displays remain ON.</li> </ul>												
Edl F 0 no00	<p><b>Error indication</b></p> <ul style="list-style-type: none"> <li>Selects error code indication Enabled/Disabled when input errors occur.</li> <li>When 'Enabled' is selected, error codes below are indicated on the PV Display.</li> </ul> <table border="1" style="width: 100%; border-collapse: collapse;"> <thead> <tr> <th style="text-align: center;">Error Code</th> <th style="text-align: center;">Error Contents</th> </tr> </thead> <tbody> <tr> <td style="text-align: center;">E-05</td> <td>PV has exceeded Input range high limit value (scaling high limit value for DC voltage, current inputs).</td> </tr> <tr> <td style="text-align: center;">E-06</td> <td>PV has dropped below Input range low limit value (scaling low limit value for DC voltage, current inputs).</td> </tr> <tr> <td style="text-align: center;">E-07</td> <td>Input burnout, or PV has exceeded or drop below the Indication range and Control range. See p.123.</td> </tr> </tbody> </table> <ul style="list-style-type: none"> <li>Selection item:</li> </ul> <table border="1" style="width: 100%; border-collapse: collapse;"> <tr> <td style="text-align: center;">no00</td> <td style="text-align: left;">Disabled</td> </tr> <tr> <td style="text-align: center;">YES0</td> <td style="text-align: left;">Enabled</td> </tr> </table>	Error Code	Error Contents	E-05	PV has exceeded Input range high limit value (scaling high limit value for DC voltage, current inputs).	E-06	PV has dropped below Input range low limit value (scaling low limit value for DC voltage, current inputs).	E-07	Input burnout, or PV has exceeded or drop below the Indication range and Control range. See p.123.	no00	Disabled	YES0	Enabled
Error Code	Error Contents												
E-05	PV has exceeded Input range high limit value (scaling high limit value for DC voltage, current inputs).												
E-06	PV has dropped below Input range low limit value (scaling low limit value for DC voltage, current inputs).												
E-07	Input burnout, or PV has exceeded or drop below the Indication range and Control range. See p.123.												
no00	Disabled												
YES0	Enabled												

At this stage, settings for Engineering setting mode 2 are complete.

Press the RST key. The unit reverts to RUN mode.

## 8.7 Clearing Data

If data is cleared, all data will revert to factory default values.

Data can be cleared only in Program control STOP (in Standby).

Data cannot be cleared during program control RUN.





### Caution





Once data clear is executed, initial settings and each setting should be set again.

(Cleared data cannot be restored.)

In preparation for mistaken execution of data clear, please write down initial settings and other setting data in the data sheets at the end of this manual.

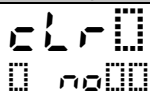
#### • To execute data clear

In RUN mode, and while in program control STOP (in Standby), if the ,  and **STOP** keys (in that order) together for approx. 3 seconds, the unit enters [Data clear Yes/No].

Characters, Factory Default	Setting Item, Function, Setting Range
	<p><b>Data clear Yes/No</b></p> <ul style="list-style-type: none"> <li>Selects if data clear is executed or not.</li> </ul> <p>Select 'Data clear No', and press the <b>MODE</b> key. Data will not be cleared, and the unit will return to RUN mode.</p> <p>Select 'Data clear Yes', and press the <b>MODE</b> key. The PV Display indicates  for approx. 3 seconds, and all data will return to factory default values. After that the unit automatically reverts to RUN mode.</p> <ul style="list-style-type: none"> <li>Selection item:</li> </ul>
	Data clear No
	Data clear Yes

# 9. Operation

## 9.1 Performing Program Control

### 9.1.1 Performing Program Control

#### (1) Before turning the power ON

Check Sections “3. Mounting to the Control Panel (pp.12 - 15)” and “4. Wiring (pp.16 - 25)” before turning the power ON.

#### (2) After turning the power ON

Set necessary setting items after turning the power ON.

Refer to Sections “5. Outline of Key Operation and Each Mode (pp.26-28)”, “6. Initial Settings (pp. 29-36)”, “7. Basic Settings and Operation (pp.37-42)” and “8. Explanation of Setting Items” (pp.43-85).

#### (3) Selecting a pattern number

There are 2 methods for selecting a pattern number:

Using the **PTN** key, or using Event input

Pattern numbers selected by Event input have priority over pattern numbers selected by the key.

To select pattern numbers by keypad, make sure all Event inputs are in OFF (Open) status.

- **Using the **PTN** key**

Select a pattern from 1 – 10 in Program control STOP (in Standby) with the **PTN** key.

- **Using Event input**

If **□□□** (Pattern number selection) is selected in [Event input DI1 allocation] and [Event input DI2 allocation]:

Select a pattern from 2 – 4, depending on ON (Closed) or OFF (Open) status between Event input DI1/DI2 terminal and SG terminal.

Select pattern 1 or a pattern from 5 – 10 with the **PTN** key.

Signal edge action is engaged. However, when power is turned ON, level action is engaged.

If **□□□** (Pattern number selection) is selected only in [Event input DI1 allocation]:  
(e.g.) To select Pattern 2, close (ON) ⑨ and ⑫.

(Table 9.1.1-1)

Pattern number Terminal number	*	2
⑨ Event input DI1	OFF (Open)	ON (Closed)

\* This number will be selected by keypad.

If **□□□** (Pattern number selection) is selected only in [Event input DI2 allocation]:  
(e.g.) To select Pattern 2, close (ON) ⑧ and ⑫.

(Table 9.1.1-2)

Pattern number Terminal number	*	2
⑧ Event input DI2	OFF (Open)	ON (Closed)

\* This number will be selected by keypad.

If 0001 (Pattern number selection) is selected in [Event input DI1 allocation] and [Event input DI2 allocation]:

(e.g.) To select Pattern 4, close (ON) ⑨ – ⑫, and ⑧ – ⑫.

(Table 9.1.1-3)

Pattern number Terminal number	*	2	3	4
⑨ Event input DI1	OFF (Open)	ON (Closed)	OFF (Open)	ON (Closed)
⑧ Event input DI2	OFF (Open)	OFF (Open)	ON (Closed)	ON (Closed)

\* This number will be selected by keypad.

#### (4) Perform Program Control

There are 2 ways to start program control.

Using the **RUN** key, or using Event input.

- Using the **RUN** key

Press the **RUN** key in Program control STOP (in Standby).

Program control starts.

- Using Event input

If 0003 (Program control RUN/STOP) is selected in [Event input DI□ allocation], Program control RUN/STOP can be switched, depending on ON (Closed) or OFF (Open) status between Event input DI1/DI2 terminal and SG terminal.

If 0003 (Program control RUN/STOP) is selected in [Event input DI1 allocation], close (ON) ⑨ and ⑫.

Program control will start.

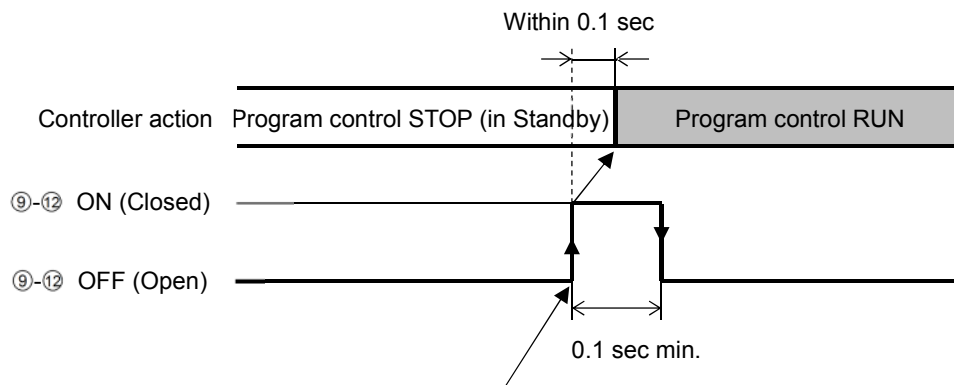

Program control performs by detecting rising signal edge action from OFF (Open) to ON (Closed) of terminals ⑨ and ⑫.

(Fig. 9.1.1-1)

### [Program control start type]

Program control start type can be selected in [Program control start type].

#### **PV start:**

Only when program control starts, step SV and step time are advanced to the PV, then program control starts.

However, if step SV set in [Step SV when program control starts] is higher than the PV (when PV start is initiated), then program control will start from the SV set in [Step SV when program control starts].

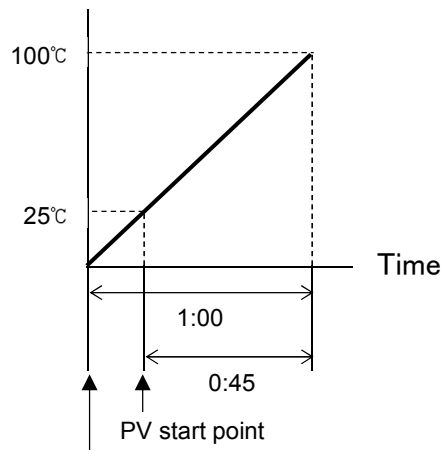

When program control starts,  
step SV is advanced to PV (25°C).

(Fig. 9.1.1-2)

#### **PVR start:**

When program control starts and in pattern repeating, the step SV and step time are advanced to the PV, then the program control starts.

Action is the same as that of PV start. Refer to (Fig. 9.1.1-2).

#### **SV start:**

Program control starts from the value set in [Step SV when program control starts].

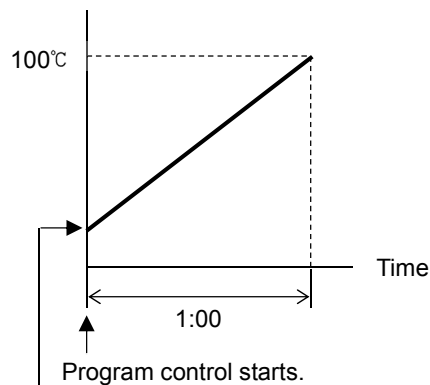

Program control starts from the value set  
in [Step SV when program control starts].

(Fig. 9.1.1-3)



### **[Power Restore Action]**

If power fails during program control, the controller can be operated depending on the selection in [Power restore action].

Progressing time error when power is restored: 1 minute or 1 second

- Stops after power is restored:  
After power is restored, stops current program control, and returns to Program control STOP (in Standby) status.
  
- Continues after power is restored:  
After power is restored, continues (resumes) program control.
  
- Suspends after power is restored:  
After power is restored, suspends (on hold) current program, and performs Fixed value control using the step SV from the point of suspension.  
Pressing the **RUN** key cancels suspension, and program control resumes.

**[Wait function]**

While program control is running, the program does not proceed to the next step until the deviation between PV and SV enters  $SV \pm \text{Wait value}$  at the end of step. The PV Display and PTN/STEP Display flash while the Wait function is working.

**Explanation of Wait function**

**• When program pattern is rising:**

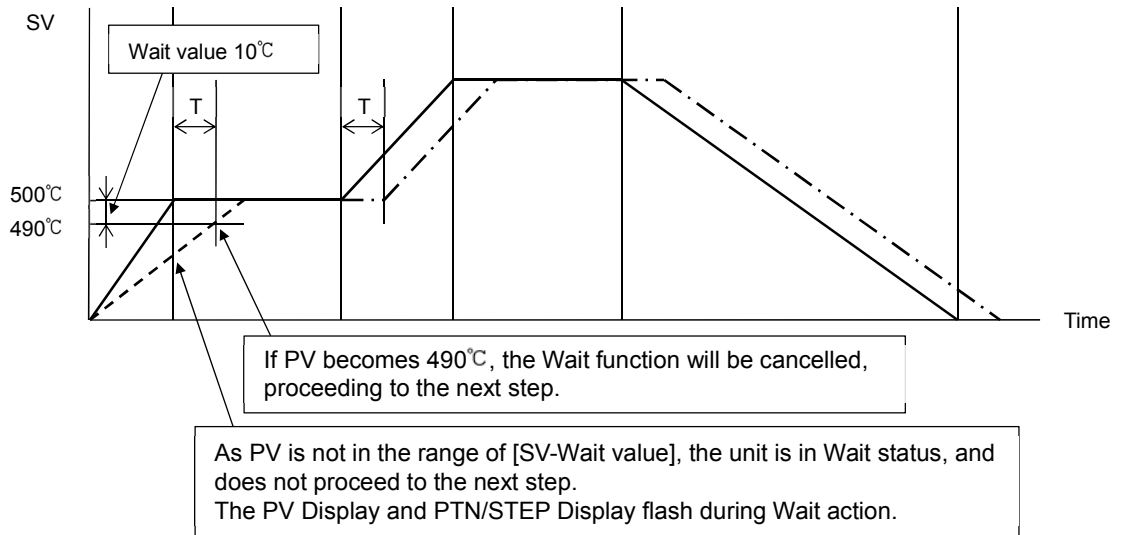

(Fig. 9.1.1-4)

**• When program pattern is falling:**

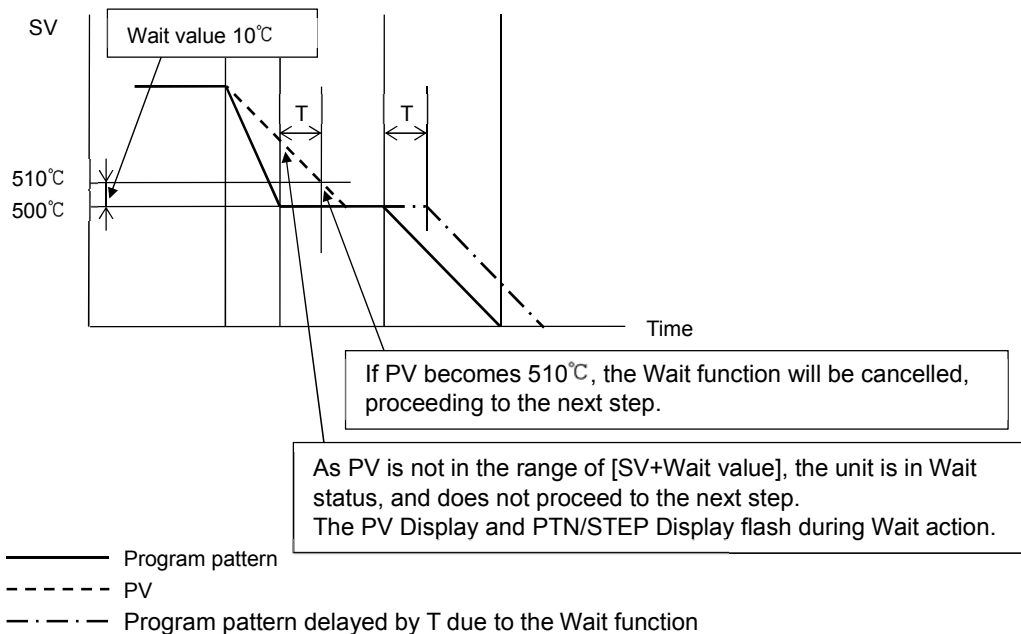

(Fig. 9.1.1-5)

**• How to cancel the Wait function**

Press the **RUN** key for approx. 1 second to cancel the Wait function.

The Wait function can also be cancelled by selecting **005** (Program control ADVANCE function) in [Event input DI□ allocation], and closing (ON) any terminal of Event input DI□ and SG terminal.

### 9.1.2 Stopping Program Control

There are 2 methods for stopping program control:

Using the **STOP** key or using Event input

- **Using the **STOP** key**

Press the **STOP** key for approximately 1 second during Program control RUN.

Program control will stop, and revert to program control STOP (in Standby) status.

- **Using Event input**

If **003** (Program control RUN/STOP) is selected in [Event input DI□ allocation], Program control RUN/STOP can be switched, depending on ON (Closed) or OFF (Open) status between Event input DI□ terminal and SG terminal.

If **003** (Program control RUN/STOP) is selected in [Event input DI1 allocation], open (OFF) ⑨ and ⑫.

Program control will stop, and the unit will revert to Program control STOP (in Standby) status.

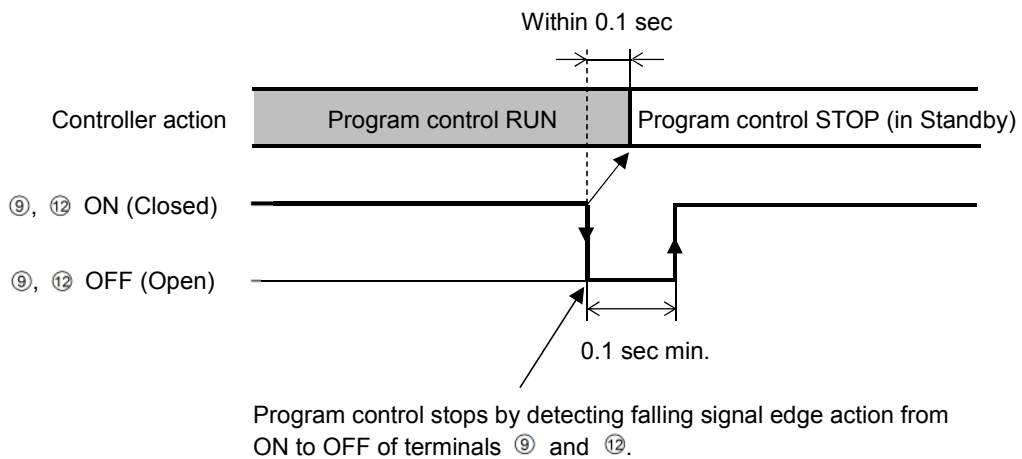

(Fig. 9.1.2-1)

### 9.1.3 Suspending Program Control (Program Control Hold Function)

During program control, progress of current step can be suspended (paused).

Fixed value control is performed using the SV at the point of suspension.

Pressing the **RUN** key cancels suspension, and program control resumes.

To suspend program control, there are 2 methods:

Using the  key, or using Event input

- **Using the  key**

Pressing the  key for approx. 1 second during program control.

Progress of current step is suspended, and then Fixed value control is performed using the SV from the point of suspension.

The PV Display and RUN indicator flash.

- **Using Event input**

If  (Program control Holding/Not holding) is selected in [Event input DI allocation], Program control Holding/Not holding can be switched, depending on ON (Closed) or OFF (Open) status between Event input DI terminal and SG terminal.

If  (Program control Holding/Not holding) is selected in [Event input DI1 allocation], close (ON) ⑨ and ⑫.

Progress of current step is suspended, and then Fixed value control is performed using the SV at the point of suspension.

The PV Display and RUN indicator flash.

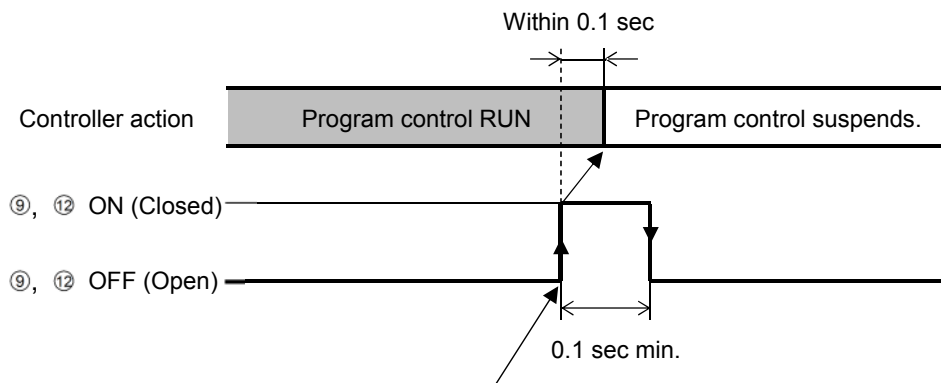

Program control suspends by detecting rising signal edge action from OFF (Open) to ON (Closed) of terminals ⑨ and ⑫.

(Fig. 9.1.3-1)

### 9.1.4 Advancing Program Step (Advance Function)

Interrupts current step while program control is running, and proceeds to the beginning of the next step.

If the Wait function is working, the Wait function will be cancelled, and will proceed to the beginning of the next step.

To advance program step, there are 2 methods:

Using the **RUN** key, or using Event input

- **Using the **RUN** key**

Press the **RUN** key for approx. 1 second during program control RUN.

Current step is stopped, and the unit proceeds to the beginning of the next step.

Each time the **RUN** key is pressed for approx. 1 second, the unit proceeds to the next step.

- **Using Event input**

If **005** (Program control Advance function) is selected in [Event input DI□ allocation], Program control ADVANCE or usual control can be switched, depending on ON (Closed) or OFF (Open) status between Event input DI□ terminal and SG terminal.

If **005** (Program control Advance function) is selected in [Event input DI1 allocation], close (ON) ⑨ and ⑫.

Current step is stopped, and the unit proceeds to the beginning of the next step.

Each time terminals ⑨ and ⑫ are turned from OFF (Open) to ON (Closed), the unit proceeds to the next step.

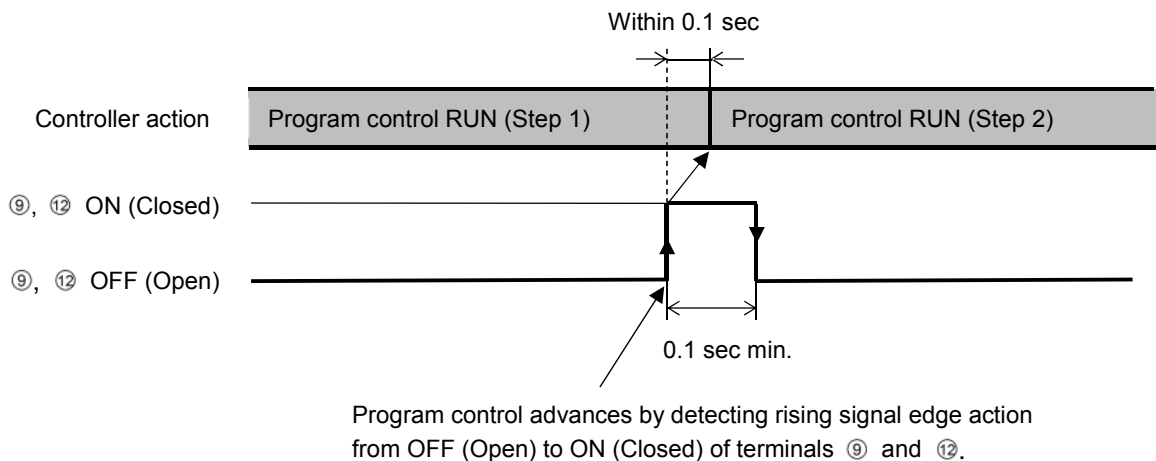

(Fig. 9.1.4-1)

### 9.1.5 Speeding up Program Step Time (Step Time Speed-up Function)

To make program step time progress faster, press the **FAST** key during program control RUN. While the **FAST** key is pressed, the step time progress is made 60 times faster.

If the Wait function is set, this function will be disabled as the Wait function has priority.

### 9.1.6 Changing Program Step SV and Step Time

When step SV and step time are changed during program control RUN, they will change as follows.

- When changing step SV from 500 to 700°C

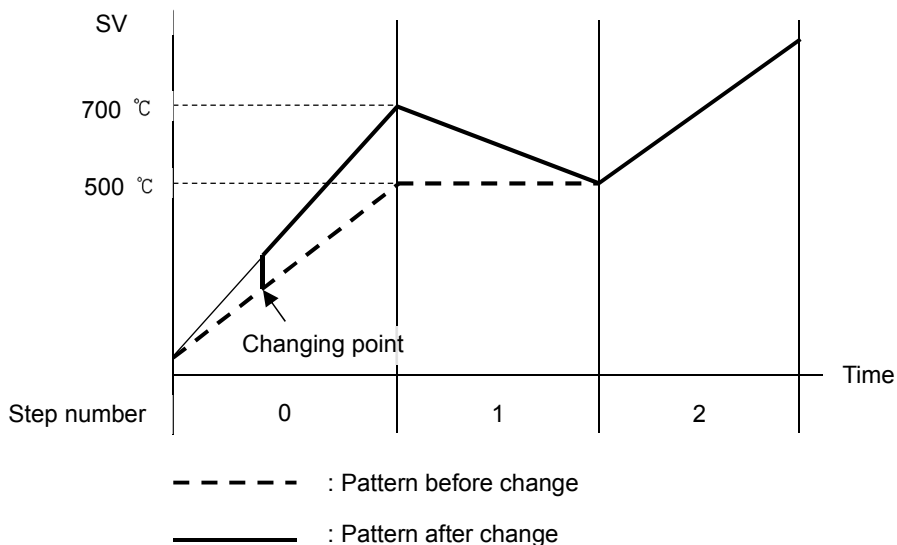

(Fig. 9.1.6-1)

- When changing step time from 0:30 to 0:50

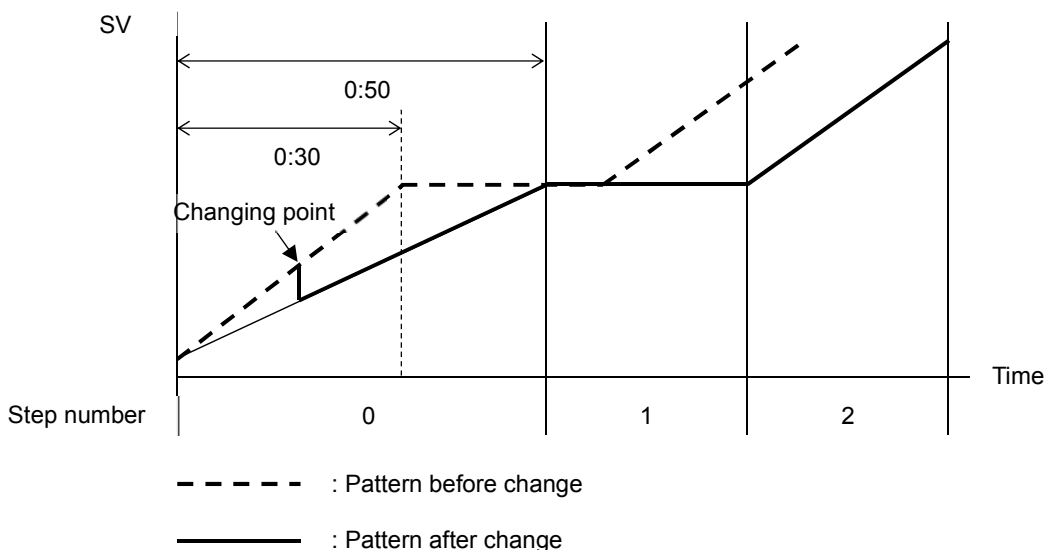

(Fig. 9.1.6-2)

### 9.1.7 Ending Program (Pattern End Function)

If (Pattern end output) is selected in [Event output EV□ allocation], Pattern end output is turned ON after program control is finished, and the SV Display flashes *PEnd*.

By pressing the **STOP** key for approximately 1 second, Pattern end output is turned OFF, and the unit returns to Program control STOP (in Standby).

If Pattern end output time is set, Pattern end output is automatically turned OFF after Pattern end output time has expired. And the unit returns to Program control STOP (in Standby).

## 9.2 Performing Fixed Value Control

### 9.2.1 Performing Fixed Value Control

Fixed value control (control action that indicating controllers are performing) is performed using the set step SV.

To perform Fixed value control, set the step time (of the desired step SV) to - - - - .

(e.g.) Set Pattern 1, Step 1 SV to 500°C, and set its step time to - - - - .

Press the **RUN** key. Fixed value control is performed at 500°C.

#### (1) Before turning the power ON

Check Sections “3. Mounting to the Control Panel (pp.12-15)” and “4. Wiring (pp.16-25)” before turning the power ON.

#### (2) After turning the power ON

Set necessary items after turning the power ON.

Refer to Sections “5. Outline of Key Operation and Explanation of Each Mode (pp.26-28)”, “6. Initial Settings (pp.29-36)”, “7. Basic Settings and Operation (pp.37-42)” and “8. Explanation of Setting Items (pp.43-85)”.

To perform Fixed value control. set the step SV and step time for the desired pattern.

To set the step time, press the  key at 00:00. - - - - will be selected.

Select a PID block number.

#### (3) Selecting a pattern number to perform

There are 2 methods for selecting a pattern number:

Using the **PTN** key, or using Event input

Pattern numbers selected by Event input have priority over pattern numbers selected by the **PTN** key.

To select pattern numbers by keypad, make sure all Event inputs are in OFF (Open) status.

##### • Using the **PTN** key

In Program control STOP (in Standby), select a pattern (from 1 – 10) for which step time is set to - - - - at (2), using the **PTN** key.

##### • Using Event input

If  (Pattern number selection) is selected in [Event input DI□ allocation], select a pattern from 2 – 4, depending on ON (Closed) or OFF (Open) status between Event input DI1/DI2 terminal and SG terminal.

To select Pattern 1 or a pattern from 5 – 10, press the **PTN** key.

Edge action is used. However, when power is turned ON, level action is engaged.

If  (Pattern number selection) is selected only in [Event input DI1 allocation], (e.g.) To select Pattern 2, close (ON) ⑨ and ⑫.

(Table 9.2.1-1)

Pattern number Terminal number	*	2
⑨ Event input DI1	OFF (Open)	ON (Closed)

\* This number will be selected by keypad.

If **000** (Pattern number selection) is selected only in [Event input DI2 allocation], (e.g.) To select Pattern 2, close (ON) ⑧ and ⑫.

(Table 9.2.1-2)

Pattern number Terminal number	*	2
⑧ Event input DI2	OFF (Open)	ON (Closed)

\* This number will be selected by keypad.

If **000** (Pattern number selection) is selected in [Event input DI1 allocation] and [Event input DI2 allocation]:

(e.g.) To select Pattern 4, close (ON) ⑨-⑫, and ⑧-⑫

(Table 9.2.1-3)

Pattern number Terminal number	*	2	3	4
⑨ Event input DI1	OFF (Open)	ON (Closed)	OFF (Open)	ON (Closed)
⑧ Event input DI2	OFF (Open)	OFF (Open)	ON (Closed)	ON (Closed)

\* This number will be selected by keypad.

#### (4) Executing Fixed Value Control

There are 2 ways to execute Fixed value control:

Using the **RUN** key, or using Event input

- **Using the **RUN** key.**

Press the **RUN** key in Program control STOP (in Standby).

The step, for which step time is set to - - - - at (2), is held, and Fixed value control is performed using the step SV.

The RUN indicator flashes during Fixed value control.

- **Using Event input**

If **003** (Program control RUN/STOP) is selected in [Event input DI□ allocation], Program control RUN/STOP can be switched, depending on ON (Closed) or OFF (Open) status between Event input DI1/DI2 terminal and SG terminal.

If **003** (Program control RUN/STOP) is selected in [Event input DI□ allocation], close (ON) ⑨ and ⑫.

The step, for which step time is set to - - - - at (2), is held, and Fixed value control is performed using the step SV.

The RUN indicator flashes during Fixed value control.

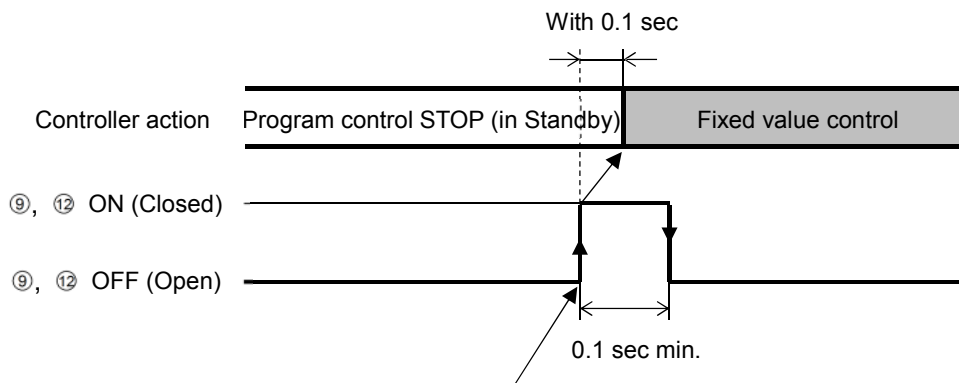

Fixed value control is performed by detecting rising signal edge action from OFF (Open) to ON (Closed) of terminals ⑨ and ⑫.

(Fig. 9.2.1-1)



### 9.2.2 Finishing Fixed Value Control

There are 2 ways to finish Fixed value control:

Using the **STOP** key, or using Event input

- **Using the **STOP** key**

Press the **STOP** key for approximately 1 second during Fixed value control.

Fixed value control will stop, and the unit will revert to Program control STOP (in Standby).

- **Using Event input**

If **003** (Program control RUN/STOP) is selected in [Event input DI□ allocation], Program control RUN/STOP can be switched, depending on ON (Closed) or OFF (Open) status between Event input DI□ terminal and SG terminal.

If **003** (Program control RUN/STOP) is selected in [Event input DI□ allocation], open (OFF) ⑨ and ⑫.

Fixed value control will stop, and the unit will revert to Program control STOP (in Standby).

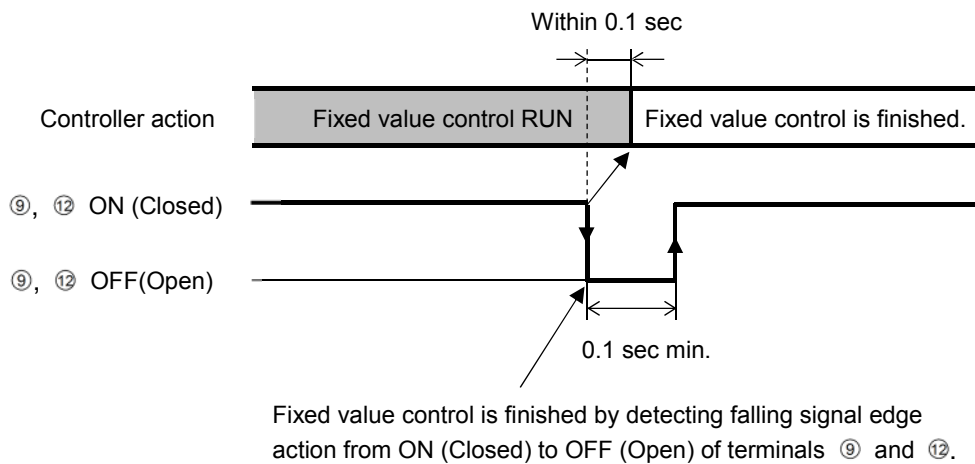

(Fig. 9.2.2-1)

### 9.3 Switching Indication of the SV Display

Press the **PTN** key to switch the indication of the SV Display.

Each time the **PTN** key is pressed, switches the indication as follows.

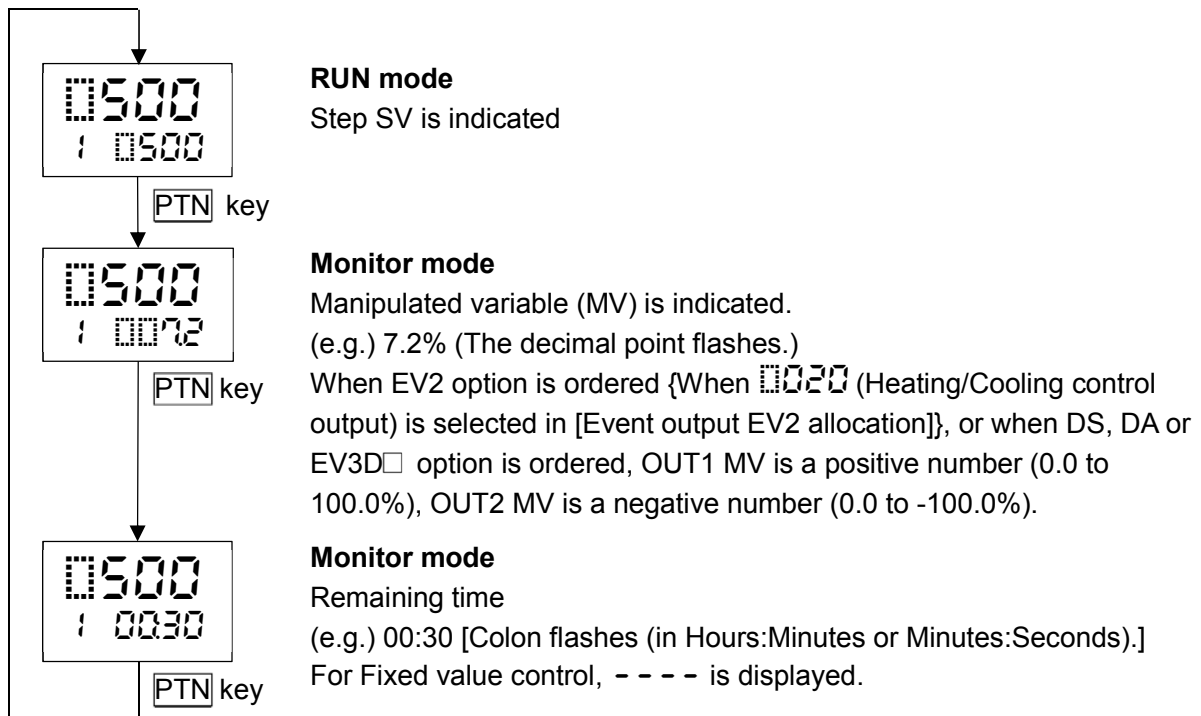

## 9.4 Performing AT

### 9.4.1 Notice when Performing AT



## Notice

- Perform the AT during the test operation.
- During the AT, none of the setting items can be set.
- If power failure occurs during AT, AT will stop.
- If AT is cancelled during the process, P, I, D and ARW values will revert to the values before AT was performed.
- AT will be forced to stop if it has not been completed within 4 hours.
- Sometimes the AT process will not fluctuate if AT is performed at or near room temperature. Therefore AT might not finish normally.

### [Notice when performing AT during Program control RUN]

- If AT is performed, AT starts from the AT starting point, and step time does not progress until AT finishes. After AT finishes, remaining step will be performed.

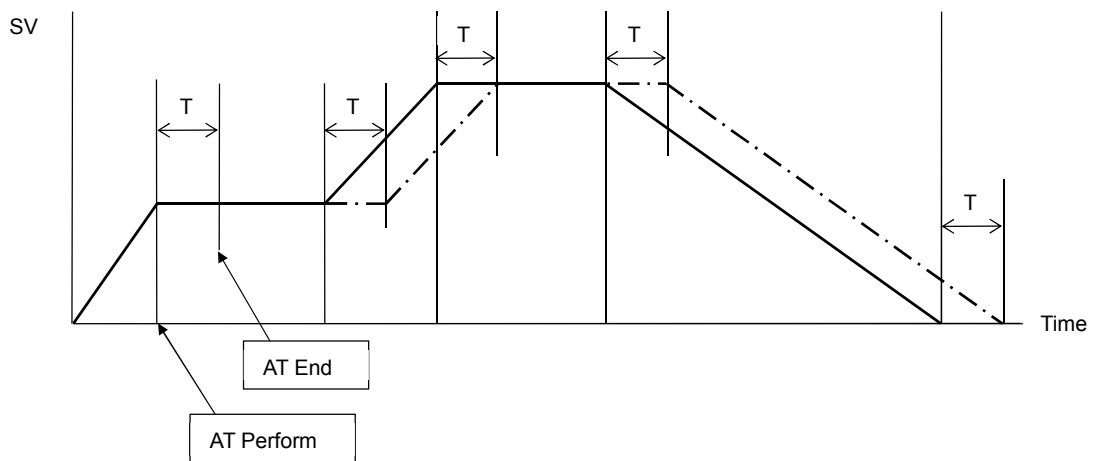

T: Time delay due to AT

———— : Program pattern before AT is performed.

- · - · - · : Program pattern after AT is performed.

(Fig. 9.4.1-1)

### 9.4.2 AT Action

In order to set each value of P, I, D and ARW automatically, the AT process should be made to fluctuate to obtain an optimal value.

For DC voltage, current inputs, the AT process will fluctuate around the SV for conditions of [A], [B] and [C] below.

One of 3 types of fluctuation below is automatically selected depending on the deviation between SV and PV.

#### [A] If there is a large difference between the SV and PV as the temperature is rising

When AT bias is set to 20°C, AT process will fluctuate at the temperature 20°C lower than the SV.

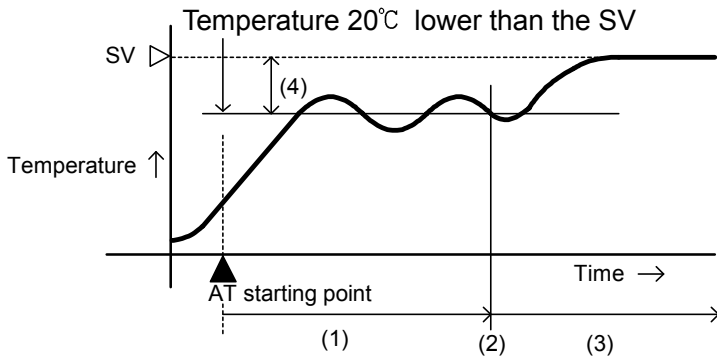

- (1) Calculates PID constants.
- (2) PID constants calculated
- (3) Controlled by the PID constants set by AT.
- (4) AT bias value (Factory default: 20°C)

(Fig. 9.4.2-1)

#### [B] When the control is stable

The AT process will fluctuate around the SV.

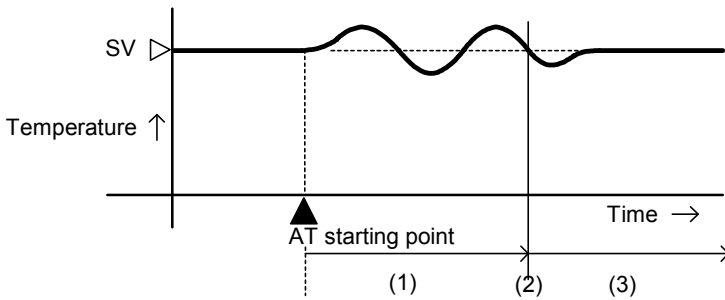

- (1) Calculates PID constants.
- (2) PID constants calculated
- (3) Controlled by the PID constants set by AT.

(Fig. 9.4.2-2)

#### [C] If there is a large difference between the SV and PV as the temperature is falling

When AT bias is set to 20°C, AT process will fluctuate at the temperature 20°C higher than the SV.

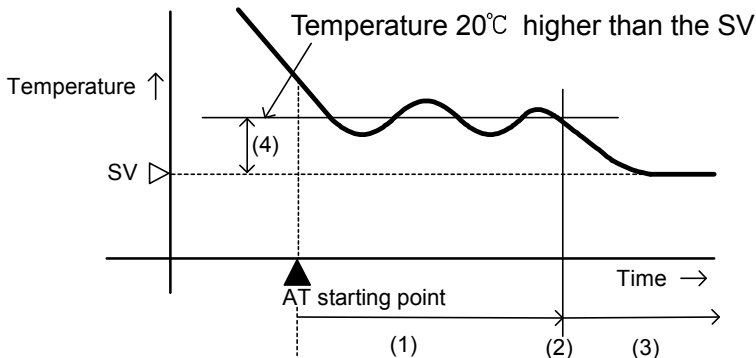

- (1) Calculates PID constants.
- (2) PID constants calculated
- (3) Controlled by the PID constants set by AT.
- (4) AT bias value (Factory default: 20°C)

(Fig. 9.4.2-3)

### 9.4.3 Performing AT

To perform AT, select **AT** (AT Perform) in [AT Perform/Cancel] in Control parameter setting mode. And press the **RST** key.

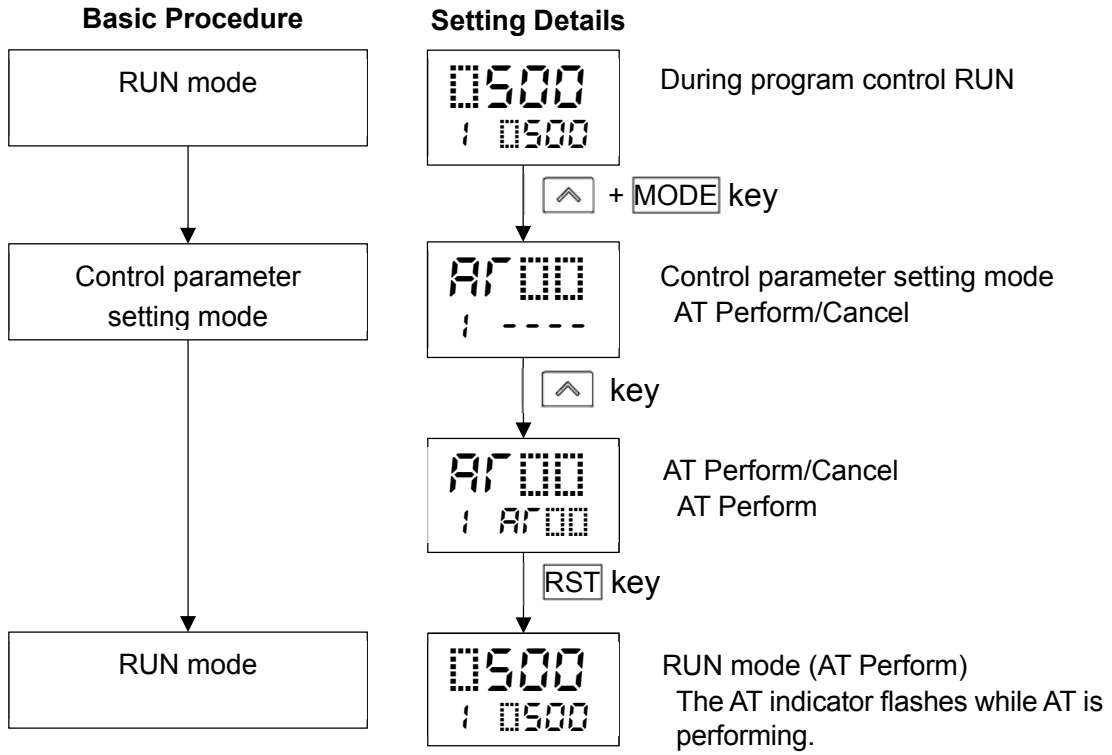

## 9.5 Input Value Correction

Input value can be corrected in [Sensor correction coefficient] and [Sensor correction] in Engineering setting mode 1.

In [Sensor correction coefficient], set the slope of temperature change.

In [Sensor correction], set the difference between temperatures before correction and after correction.

PV after input correction is expressed by the following formula.

PV after input correction = Current PV x Sensor correction coefficient + (Sensor correction value)

The following shows an example of input value correction using 'Sensor correction coefficient' and 'Sensor correction value'.

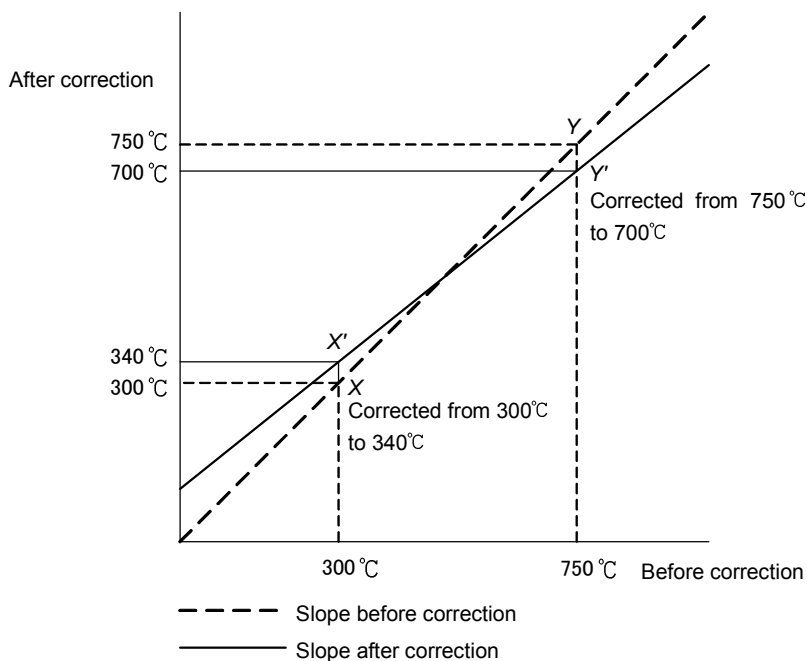

(Fig. 9.5-1)

- (1) Select any 2 points of PV to be corrected, and determine the PV after correction.  
 PV before correction: 300°C → PV after correction: 340°C  
 PV before correction: 750°C → PV after correction: 700°C
- (2) Calculate Sensor correction coefficient from Step (1).  
 $(Y' - X') / (Y - X) = (700 - 340) / (750 - 300) = 0.8$
- (3) Enter a PV value of 300°C using an mV generator or dial resistor.
- (4) Set Step (2) value as a Sensor correction coefficient.
- (5) Read the PV.  
 240°C will be indicated.
- (6) Calculate the sensor correction value.  
 Calculate the difference between 'PV after correction' and Step (5) PV.  
 $340°C - 240°C = 100°C$
- (7) Set Step (6) value as a Sensor correction value.
- (8) Enter an electromotive force or resistance value equivalent to 750°C using an mV generator or dial resistor.
- (9) Read the PV, and confirm that 700°C is indicated.

**(Example) Setting Sensor correction coefficient to 0.800, and Sensor correction to 100.0°C**

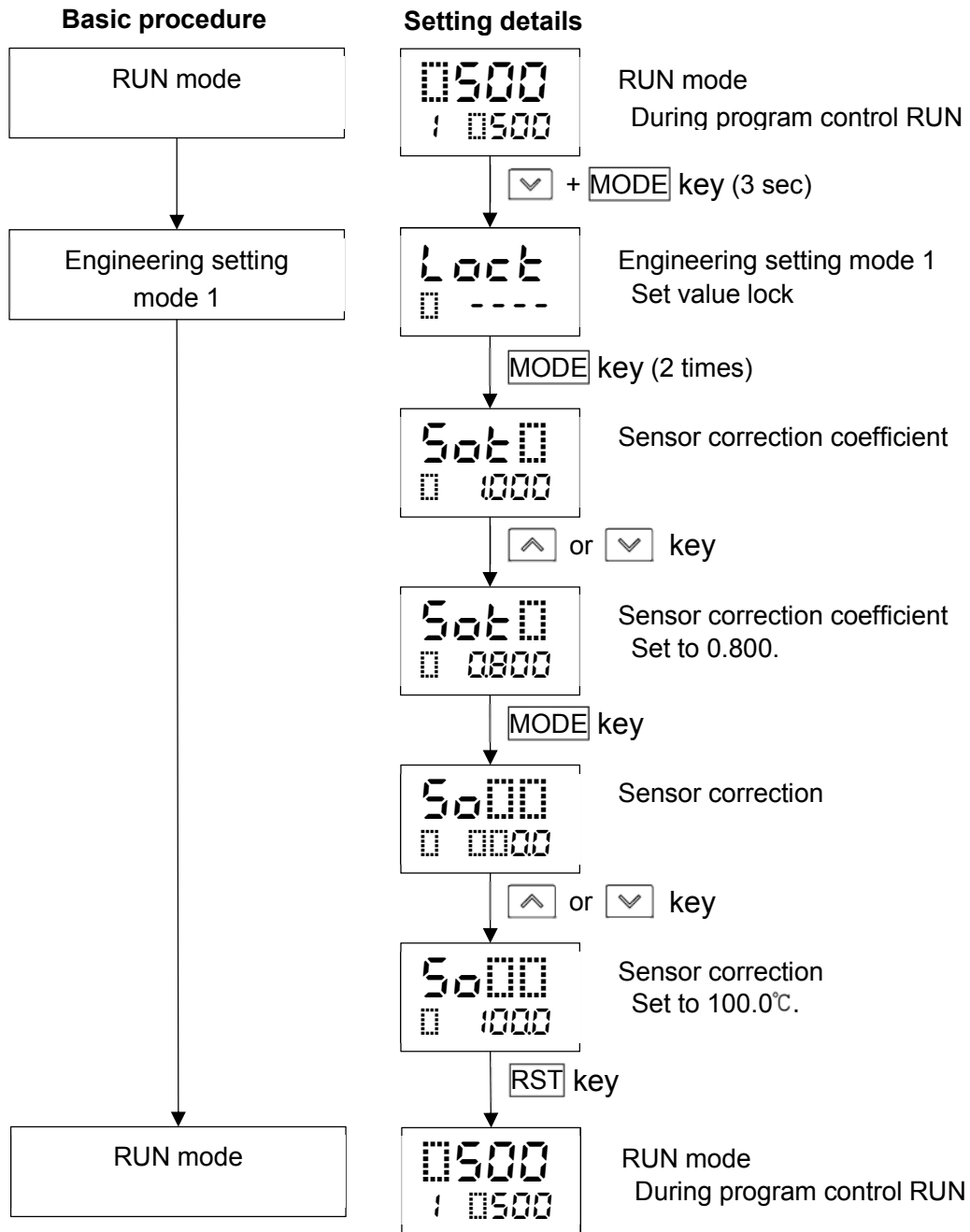

## 9.6 Items to be Initialized by Changing Settings

If settings are changed, the following items will be initialized.

●: Initialized

x: Not initialized

Setting item to be changed Item to be initialized	Input Type	Event output EV1 allocation	Event output EV2 allocation	Event output EV3 allocation	Transmission output
Loop break alarm time	●	x	x	x	x
Loop break alarm span	●	x	x	x	x
Sensor correction coefficient	●	x	x	x	x
Sensor correction	●	x	x	x	x
SVTC bias	●	x	x	x	x
Scaling high limit	●	x	x	x	x
Scaling low limit	●	x	x	x	x
EV1 alarm value 0 Enabled/Disabled	x	●	x	x	x
EV1 alarm hysteresis	x	●	x	x	x
EV1 alarm delay time	x	●	x	x	x
EV1 alarm Energized/De-energized	x	●	x	x	x
EV2 alarm value 0 Enabled/Disabled	x	x	●	x	x
EV2 alarm hysteresis	x	x	●	x	x
EV2 alarm delay time	x	x	●	x	x
EV2 alarm Energized/De-energized	x	x	●	x	x
EV3 alarm value 0 Enabled/Disabled	x	x	x	●	x
EV3 alarm hysteresis	x	x	x	●	x
EV3 alarm delay time	x	x	x	●	x
EV3 alarm Energized/De-energized	x	x	x	●	x
Transmission output high limit *	●	x	x	x	●
Transmission output low limit *	●	x	x	x	●
Step SV when program control starts	●	x	x	x	x
AT bias	●	x	x	x	x

\* When PV transmission or SV transmission is selected, and if input type is changed, these setting items will be initialized.



# 10. Action Explanation

## 10.1 OUT1 Action

	Reverse (Heating) action	Direct (Cooling) action
Control action		
Relay contact output	<p>Cycle action is performed according to deviation.</p>	<p>Cycle action is performed according to deviation.</p>
Non-contact voltage output	<p>Cycle action is performed according to deviation.</p>	<p>Cycle action is performed according to deviation.</p>
Direct current output	<p>Changes continuously according to deviation.</p>	<p>Changes continuously according to deviation.</p>
Indicator (OUT) Green	<p>Lit Unlit</p>	<p>Unlit Lit</p>

: Turns ON or OFF.

## 10.2 OUT1 ON/OFF Control Action

	Reverse (Heating) action	Direct (Cooling) action
Control action		
Relay output		
Non-contact voltage output		
Direct current output		
Indicator (OUT) Green	<p>Lit Unlit</p>	<p>Unlit Lit</p>

: Turns ON or OFF.

### 10.3 Heater Burnout Alarm Action

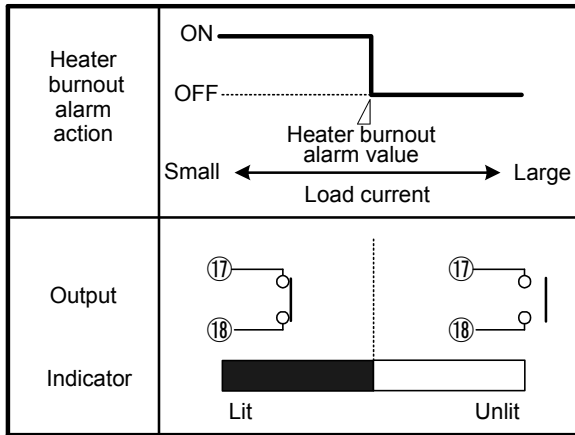

Event output EV1 terminal numbers: ⑰, ⑱

Event output EV2 terminal numbers: ⑲, ⑳

Event output EV3 terminal numbers: ⑥, ⑦

### 10.4 Alarm Action

	High limit alarm	Low limit alarm
Alarm action	<p>Diagram showing alarm action for a high limit alarm. The process value (EV1) is compared to the setpoint (SV). The alarm is ON when EV1 reaches +EV1 value and OFF when it reaches -EV1 value. Hysteresis is shown between the ON and OFF points.</p>	<p>Diagram showing alarm action for a low limit alarm. The process value (EV1) is compared to the setpoint (SV). The alarm is ON when EV1 reaches -EV1 value and OFF when it reaches +EV1 value. Hysteresis is shown between the ON and OFF points.</p>
Alarm output	<p>Diagram showing alarm output for a high limit alarm. The +side output is ON (black) when the alarm is active, and the -side output is OFF (white).</p>	<p>Diagram showing alarm output for a low limit alarm. The -side output is ON (black) when the alarm is active, and the +side output is OFF (white).</p>
	High/Low limits alarm	High/Low limits independent alarm
Alarm action	<p>Diagram showing alarm action for a combined high/low limit alarm. The alarm is ON when EV1 reaches either EV1 value (high) or EV1 value (low). Hysteresis is shown for both limits.</p>	<p>Diagram showing alarm action for independent high/low limit alarms. The alarm is ON when EV1 reaches either EV1 low limit value or EV1 high limit value. Hysteresis is shown for both limits.</p>
Alarm output	<p>Diagram showing alarm output for a combined high/low limit alarm. Both +side and -side outputs are ON (black) when either limit is reached.</p>	<p>Diagram showing alarm output for independent high/low limit alarms. The +side output is ON (black) for high limit and the -side output is ON (black) for low limit.</p>
	High/Low limit range alarm	High/Low limit range independent alarm
Alarm action	<p>Diagram showing alarm action for a range alarm. The alarm is ON when EV1 is between EV1 value (low) and EV1 value (high). Hysteresis is shown for both limits.</p>	<p>Diagram showing alarm action for independent range alarm. The alarm is ON when EV1 is between EV1 low limit value and EV1 high limit value. Hysteresis is shown for both limits.</p>
Alarm output	<p>Diagram showing alarm output for a range alarm. Both +side and -side outputs are ON (black) when the process value is within the range.</p>	<p>Diagram showing alarm output for independent range alarm. Both +side and -side outputs are ON (black) when the process value is within the range.</p>
	Process high alarm	Process low alarm
Alarm action	<p>Diagram showing alarm action for a process high alarm. The alarm is ON when EV1 reaches EV1 value and OFF when it reaches EV1 value with hysteresis.</p>	<p>Diagram showing alarm action for a process low alarm. The alarm is ON when EV1 reaches EV1 value and OFF when it reaches EV1 value with hysteresis.</p>
Alarm output	<p>Diagram showing alarm output for a process high alarm. The +side output is ON (black) when the alarm is active.</p>	<p>Diagram showing alarm output for a process low alarm. The -side output is ON (black) when the alarm is active.</p>

	High limit with standby alarm	Low limit with standby alarm
Alarm action		
Alarm output	+ side - side	+ side - side
	High/Low limits with standby alarm	High/Low limits with standby independent alarm
Alarm action		
Alarm output		

- : Event output EV1 terminals ⑰, ⑱: ON
- : Event output EV1 terminals ⑰, ⑱: ON or OFF
- : Event output EV1 terminals ⑰, ⑱: OFF
- : Alarm output is in standby.

- EV1 value, EV1 high limit value, and EV1 hysteresis represent EV1 alarm value, EV1 high limit alarm value and EV1 alarm hysteresis respectively.  
For EV2/EV3, read “EV2/EV3” for “EV1”.
- EV1 indicator lights up when Event output EV1 terminals 17 and 18 are ON, and turns off when their output terminals 17 and 18 are OFF.  
EV2 indicator lights up when Event output EV2 terminals 19 and 20 are ON, and turns off when their output terminals 19 and 20 are OFF.  
EV3 indicator lights up when Event output EV3 terminals 6 and 7 are ON, and turns off when their output terminals 6 and 7 are OFF.

### 10.5 OUT2 (Heating/Cooling Control) Action

Control action			
Relay contact output (OUT1)	<p>Cycle action is performed according to deviation.</p>		
Non-contact voltage output (OUT1)	<p>Cycle action is performed according to deviation.</p>		
Direct current output (OUT1)	<p>Changes continuously according to deviation.</p>		
Relay contact output (OUT2)	<p>Cycle action is performed according to deviation.</p>		
Non-contact voltage output (OUT2)	<p>Cycle action is performed according to deviation.</p>		
Direct current output (OUT2)	<p>Changes continuously according to deviation.</p>		
Indicator (OUT)			
Indicator (EV2)			

: Turns ON (Lit) or OFF (Unlit).

: Represents Heating control action.

: Represents Cooling control action.

### 10.6 OUT2 (Heating/Cooling Control) Action (When Setting Dead Band)

Control action			
Relay contact output (OUT1)	<p>Cycle action is performed according to deviation.</p>		
Non-contact voltage output (OUT1)	<p>Cycle action is performed according to deviation.</p>		
Direct current output (OUT1)	<p>Changes continuously according to deviation.</p>		
Relay contact output (OUT2)	<p>Cycle action is performed according to deviation.</p>		
Non-contact voltage output (OUT2)	<p>Cycle action is performed according to deviation.</p>		
Direct current output (OUT2)	<p>Changes continuously according to deviation.</p>		
Indicator (OUT)			
Indicator (EV2)			

: Turns ON (Lit) or OFF(Unlit).

— : Represents Heating control action.

- - - - : Represents Cooling control action.

### 10.7 OUT2 (Heating/Cooling control) Action (When Setting Overlap band)

Control action	
Relay contact output (OUT1)	<p>Cycle action is performed according to deviation.</p>
Non-contact voltage output (OUT1)	<p>Cycle action is performed according to deviation.</p>
Direct current output (OUT1)	<p>Changes continuously according to deviation.</p>
Relay contact output (OUT2)	<p>Cycle action is performed according to deviation.</p>
Non-contact voltage output (OUT2)	<p>Cycle action is performed according to deviation.</p>
Direct current output (OUT2)	<p>Changes continuously according to deviation.</p>
Indicator (OUT)	<p>Lit Unlit</p>
Indicator (EV2)	<p>Unlit Lit</p>

: Turns ON (Lit) or OFF (Unlit).

— : Represents Heating control action.

- - - - : Represents Cooling control action.

# 11. Specifications

## 11.1 Standard Specifications

### Rating

Rated scale	Input	Scale Range		Resolution
K		-200 to 1370 °C	-328 to 2498 °F	1 °C(°F)
		-200.0 to 400.0 °C	-328.0 to 752.0 °F	0.1 °C(°F)
J		-200 to 1000 °C	-328 to 1832 °F	1 °C(°F)
R		0 to 1760 °C	32 to 3200 °F	1 °C(°F)
S		0 to 1760 °C	32 to 3200 °F	1 °C(°F)
B		0 to 1820 °C	32 to 3308 °F	1 °C(°F)
E		-200 to 800 °C	-328 to 1472 °F	1 °C(°F)
T		-200.0 to 400.0 °C	-328.0 to 752.0 °F	0.1 °C(°F)
N		-200 to 1300 °C	-328 to 2372 °F	1 °C(°F)
PL-II		0 to 1390 °C	32 to 2534 °F	1 °C(°F)
C(W/Re5-26)		0 to 2315 °C	32 to 4199 °F	1 °C(°F)
Pt100		-200.0 to 850.0 °C	-328.0 to 1562.0 °F	0.1 °C(°F)
		-200 to 850 °C	-328 to 1562 °F	1 °C(°F)
JPt100		-200.0 to 500.0 °C	-328.0 to 932.0 °F	0.1 °C(°F)
		-200 to 500 °C	-328 to 932 °F	1 °C(°F)
4 – 20 mA		-2000 to 10000 (*)		1
0 – 20 mA		-2000 to 10000 (*)		1
0 – 1 V		-2000 to 10000 (*)		1
0 – 5 V		-2000 to 10000 (*)		1
1 – 5 V		-2000 to 10000 (*)		1
0 – 10 V		-2000 to 10000 (*)		1
(*) Scaling and decimal point place selection are possible.				

### Input

<b>Input</b>	<b>Thermocouple</b>	K, J, R, S, B, E, T, N, PL-II, C(W/Re5-26) External resistance: 100 Ω max. However, for B input, External resistance: 40 Ω max.
	<b>RTD</b>	Pt100, JPt100 3-wire type Allowable input lead wire resistance: 10 Ω max. per wire
	<b>Direct current</b>	0 to 20 mA DC, 4 to 20 mA DC Input impedance: 50 Ω Allowable input current: 50 mA max.
	<b>DC voltage</b>	0 – 1 V DC Input impedance: 1 MΩ min. Allowable input voltage: 5 V DC max. Allowable signal source resistance: 2 kΩ max. 0 – 5 V DC, 1 – 5 V DC, 0 – 10 V DC Input impedance: 100 kΩ min. Allowable input voltage: 15 V DC max. Allowable signal source resistance: 100 Ω max.
<b>Event input</b> (C5W, EIW, EIT, C5, EI options)		
	<b>Input point</b>	2 points
	<b>Circuit current when closed</b>	Approx. 16 mA
	<b>Action</b>	Edge action When the power is turned ON, level action is engaged.



## Output

<b>Control output OUT1</b>	<b>Relay contact 1a</b>	Control capacity: 3 A 250 V AC (resistive load) 1 A 250 V AC (inductive load $\cos \phi = 0.4$ ) Electrical life: 100,000 cycles Minimum applicable load: 10 mA 5 V DC
	<b>Non-contact voltage (for SSR drive)</b>	12 V DC $\pm 15\%$ Max. 40 mA (short circuit protected)
	<b>Direct current</b>	4 - 20 mA DC (Resolution: 12000) Load resistance: Max. 550 $\Omega$
<b>Event output EV1</b>		
	<b>Relay contact 1a</b>	Control capacity: 3 A 250 V AC (resistive load) 1 A 250 V AC (inductive load $\cos \phi = 0.4$ ) Electrical life: 100,000 cycles Minimum applicable load: 10 mA 5 V DC
<b>Event output EV2</b> [EV2, EV3(DR) options]		
	<b>Relay contact 1a</b>	Control capacity: 3 A 250 V AC (resistive load) 1 A 250 V AC (inductive load $\cos \phi = 0.4$ ) Electrical life: 100,000 cycles Minimum applicable load: 10 mA 5 V DC
<b>Event output EV3</b> (EV3D□, EI options)		
	<b>Relay contact 1a</b>	Control capacity: 3 A 250 V AC (resistive load) 1 A 250 V AC (inductive load $\cos \phi = 0.4$ ) Electrical life: 100,000 cycles Minimum applicable load: 10 mA 5 V DC
<b>Control output OUT2</b> (EV2, EV3D□ options)		
	<b>Relay contact 1a</b> [EV2, EV3(DR) options]	Control capacity: 3 A 250 V AC (resistive load) 1 A 250 V AC (inductive load $\cos \phi = 0.4$ ) Electrical life: 100,000 cycles Minimum applicable load: 10 mA 5 V DC
	<b>Non-contact voltage (for SSR drive)</b> (DS, EV3DS options)	12 V DC $\pm 15\%$ Max. 40 mA (short circuit protected)
	<b>Direct current</b> (DA, EV3DA options)	4 - 20 mA DC (Resolution: 12000) Load resistance: Max. 600 $\Omega$
<b>Transmission output</b> (EIT option)		
	<b>Resolution</b>	12000
	<b>Output</b>	4 - 20 mA DC (Load resistance: Max. 550 $\Omega$ )
	<b>Output accuracy</b>	Within $\pm 0.3\%$ of Transmission output span
	<b>Response time</b>	400 ms + Input sampling period (0% $\rightarrow$ 90%)
<b>Insulated power output</b> (P24 option)		
	<b>Output voltage</b>	24 $\pm$ 3 V DC (when load current is 30 mA DC)
	<b>Ripple voltage</b>	Within 200 mV DC (when load current is 30 mA DC)
	<b>Max. load current</b>	30 mA DC

**Power**

<b>Power supply</b>	<b>Model</b>	<b>PCB1□00-□□</b>	<b>PCB1□10-□□</b>
	Power supply	100 – 240 V AC, 50/60 Hz	24 V AC/DC, 50/60 Hz
	Allowable fluctuation range	85 – 264 V AC	20 – 28 V AC/DC
<b>Power consumption</b>	<b>Power supply</b>	<b>Power consumption</b>	
	100 – 240 V AC	Approx. 8 VA max. (When the maximum number of options are ordered: Approx. 11 VA max.)	
	24 V AC	Approx. 5 VA max. (When the maximum number of options are ordered: Approx. 8 VA max.)	
	24 V DC	Approx. 5 W max. (When the maximum number of options are ordered: Approx. 8 W max.)	
<b>Inrush current</b>	<b>Power supply</b>	<b>Inrush current</b>	
	100 – 240 V AC	Max. 14 to 34 A	
	24 V AC	Max. 34 A	
	24 V DC	Max. 34 A	

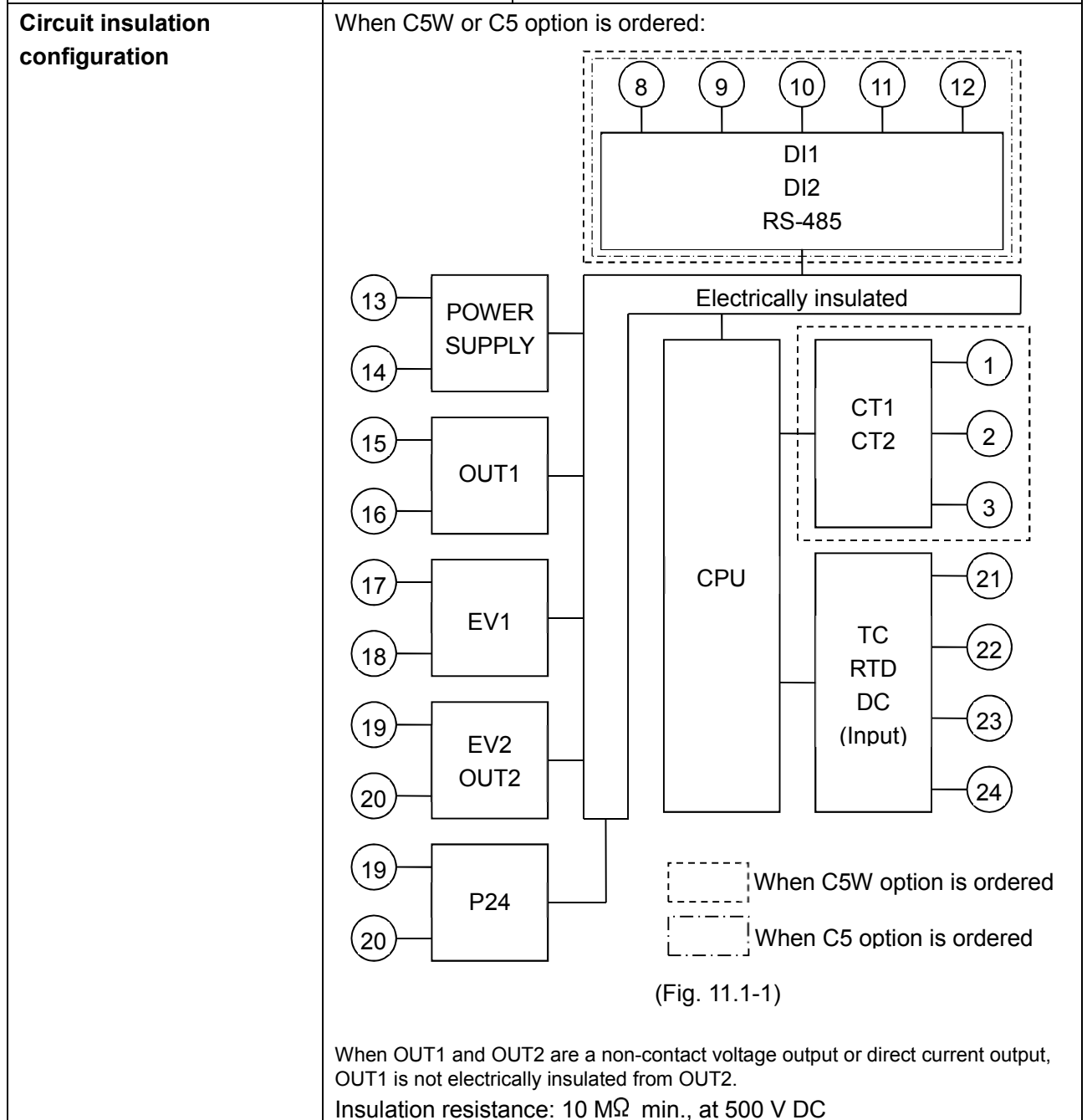

When EIW or W option is ordered:

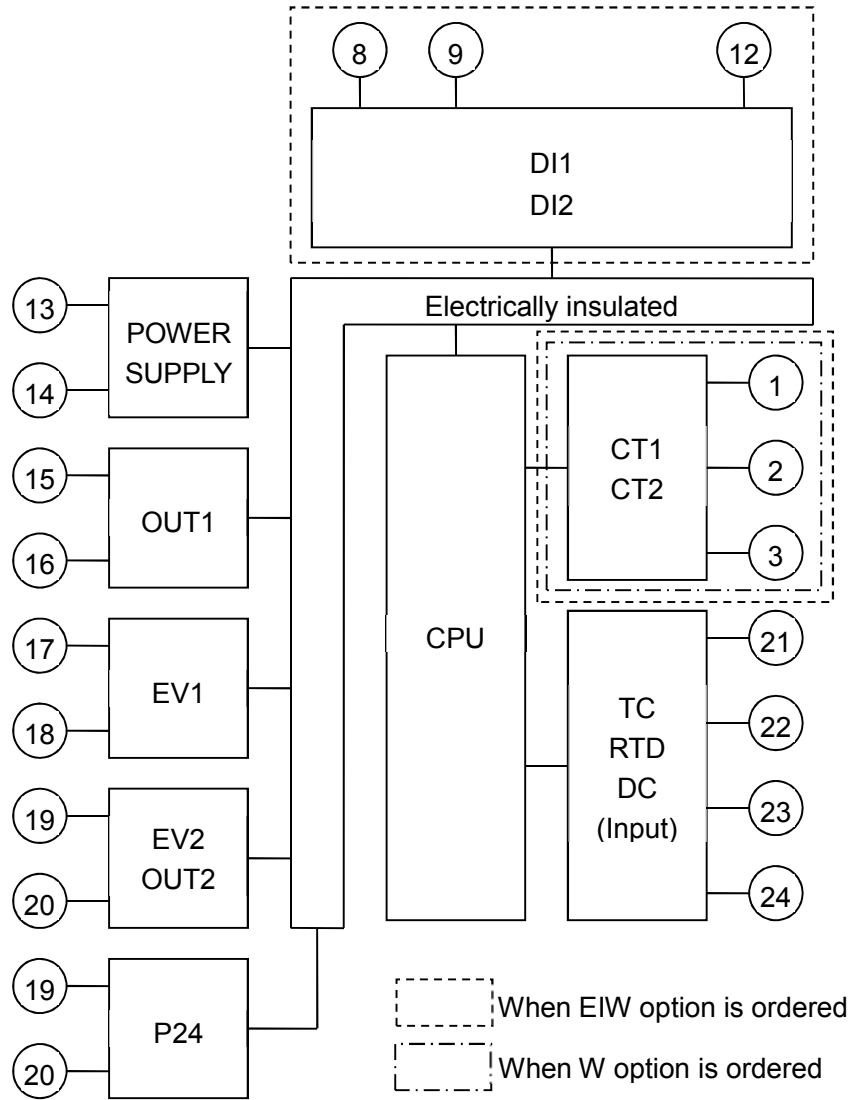

(Fig. 11.1-2)

When OUT1 and OUT2 are a non-contact voltage output or direct current output, OUT1 is not electrically insulated from OUT2.

Insulation resistance: 10 MΩ min., at 500 V DC

When EIT or EI option is ordered:

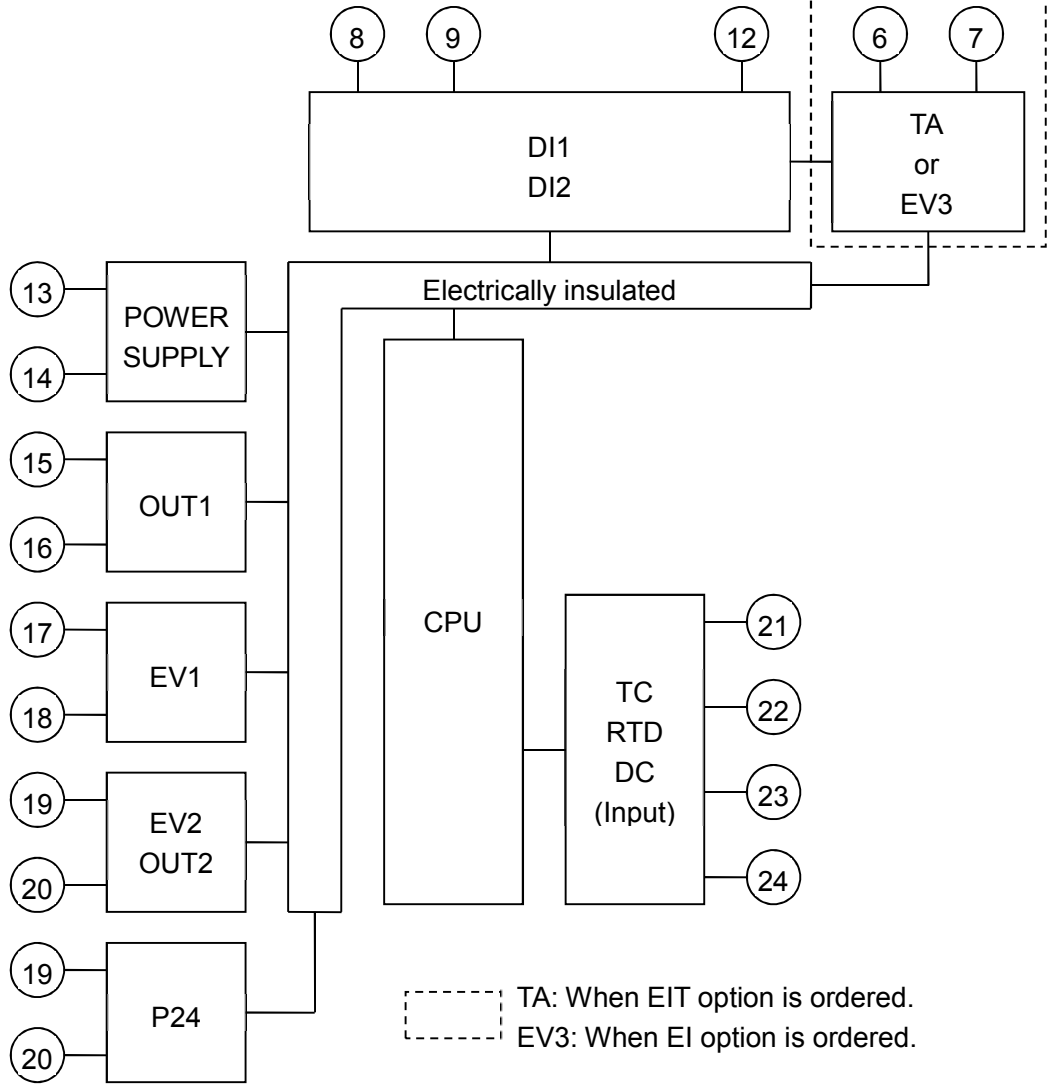

(Fig. 11.1-3)

When OUT1 and OUT2 are a non-contact voltage output or direct current output, OUT1 is not electrically insulated from OUT2.

Insulation resistance: 10 MΩ min., at 500 V DC

**Dielectric strength**

Between input terminal and power terminal: 1.5 kV AC for 1 minute  
 Between output terminal and power terminal: 1.5 kV AC for 1 minute  
 Between output terminal (P24) and power terminal: 500 V AC for 1 minute

### Recommended Environment

<b>Ambient temperature</b>	-10 to 55°C (However, non-condensing or no icing)
<b>Ambient humidity</b>	35 to 85 %RH (However, non-condensing)
<b>Environmental specification</b>	RoHS directive compliant

### Performance









<b>Base accuracy</b>	At ambient temperature 23°C (for a single unit mounting)	
	<b>Thermocouple</b>	Within $\pm 0.2\%$ of each input span $\pm 1$ digit However, R, S input, 0 to 200°C (32 to 392°F): Within $\pm 6^\circ\text{C}$ (12°F) B input, 0 to 300°C (32 to 572°F): Accuracy is not guaranteed. K, J, E, T, N input, Less than 0°C (32°F): Within $\pm 0.4\%$ of input span $\pm 1$ digit
	<b>RTD</b>	Within $\pm 0.1\%$ of each input span $\pm 1$ digit
	<b>Direct current, DC voltage</b>	Within $\pm 0.2\%$ of each input span $\pm 1$ digit
<b>Effect of ambient temperature</b>	Within 50 ppm/°C of each input span	
<b>Input sampling period</b>	125 ms	
<b>Time indication accuracy</b>	Within $\pm 0.5\%$ of setting time	
<b>Setting resolution</b>	<b>Temperature</b>	Thermocouple, RTD input without decimal point: 1°C (°F) Thermocouple, RTD input with decimal point: 0.1°C (°F) DC voltage, current input: 1
	<b>Time</b>	1 minute or 1 second

### General Structure

<b>Weight</b>	Approx. 220 g	
<b>External dimensions</b>	96 x 96 x 68 (W x H x D) (Depth of control panel interior: 60 mm)	
<b>Mounting</b>	Flush (Applicable panel thickness: 1 to 7 mm)	
<b>Case</b>	Flame-resistant resin, Color: Black	
<b>Front panel</b>	Membrane sheet	
<b>Drip-proof/Dust-proof</b>	IP66 for front panel only	
<b>Display</b>	<b>PV Display</b>	Indicates process variable (PV) in RUN mode. Indicates setting characters in setting mode. Flashes during Wait action or Program control Hold in program control. 7-segments Red LED display 4.5 digits Character size: 24.0 x 11.0 mm (H x W)
	<b>SV Display</b>	Indicates desired value (SV), Output manipulated variable (MV), or Remaining time (TIME) in RUN mode. Retains display indication at power OFF. Indicates the set values in setting mode. 7-segments Green LED display 4.5 digits Character size: 14.0 x 7.0 mm (H x W)

	<b>PTN/STEP Display</b>	<p>Indicates the pattern number or step number.</p> <p>Each time the <b>[DISP]</b> key is pressed, the PTN/STEP Display and the PTN/STEP indicator alternately indicate the pattern number and step number.</p> <p>Flashes during Wait action, or when the step number is indicated.</p> <p>If 'SV digital reception' is selected in [Communication protocol], <b>r</b> is indicated.</p> <p>7-segments Orange LED display 1.5-digits Character size:14.0 x 7.0 mm (H x W)</p>
<b>Indicator</b>	<b>PTN indicator</b>	<p>Lights up when the pattern number is indicated on the PTN/STEP Display.</p> <p>Orange LED</p>
	<b>STEP indicator</b>	<p>Lights up when the step number is indicated on the PTN/STEP Display.</p> <p>Orange LED</p>
	<b>PTN/STEP indicator</b>	<p>LED for the pattern number or step number lights up.</p> <p>Each time the <b>[DISP]</b> key is pressed, the PTN/STEP indicator and the PTN/STEP Display alternately indicate the pattern number and step number.</p> <p>Green LED 12 pieces (PTN, STEP, 1 to 10)</p>
<b>Action indicator</b>	<b>OUT (Green)</b>	<p>Lights up when control output OUT1 is ON.</p> <p>Lights up when Heating output [DS, DA, EV2 (if <b>020</b> is selected in Event output EV2 allocation), EV3D□ options] is ON.</p> <p>For direct current output type, flashes corresponding to the MV in 125 ms cycles.</p>
	<b>RUN (Orange)</b>	<p>Lights up during program control RUN.</p> <p>Flashes during Program control HOLD or Fixed value control.</p>
	<b>EV1 (Red)</b>	Lights up when Event output EV1 is ON.
	<b>EV2 (Red)</b>	<p>Lights up when Event output EV2 [(EV2, EV3(DR) options] is ON.</p> <p>Lights up when control output OUT2 [Cooling output: DS, DA, EV2 (if <b>020</b> is selected in Event output EV2 allocation), EV3D□ options] is ON.</p> <p>For direct current output type (DA, EV3DA options), flashes corresponding to the MV in 125 ms cycles.</p>
	<b>EV3 (Red)</b>	Lights up when Event output EV3 (EV3D□, EI options) is ON.
	<b>AT (Orange)</b>	Flashes while AT is performing.
	<b>T/R (Orange)</b>	<p>Lights up during serial communication (C5W, C5 options)</p> <p>TX (transmitting) output.</p>

## Setting Structure

<b>Function key</b>		<b>UP key</b>	In setting mode, increases the numerical value. By pressing for approx. 1 sec during program control RUN, time progress pauses, and Program control Hold function initiates.)
		<b>DOWN key</b>	In setting mode, decreases the numerical value.
		<b>FAST key</b>	In setting mode, makes the numeric value change faster. During program control RUN, makes step time progress 60 times faster.
		<b>RESET key</b>	In setting mode, registers the setting data, and moves to RUN mode.
		<b>MODE key</b>	In setting mode, registers the setting data, and moves to the next setting item.
		<b>PATTERN key</b>	During program control STOP (in Standby), selects a program pattern number to perform or to set. By pressing this key during program control RUN, the unit moves to Monitor mode. In Monitor mode, switches the indication item.
		<b>Display key</b>	During RUN mode, the PTN/STEP Display and PTN/STEP indicator alternately indicates the pattern number and step number. In setting mode, registers the setting data, and moves back to the previous mode.
		<b>RUN key</b>	Performs program control, or cancels Program control Hold function while program control is held. By pressing for approx. 1 second during program control RUN, stops performing step, and proceeds to the next step (Advance function initiates.)
		<b>STOP key</b>	Stops program control by pressing for approx. 1 second during program control RUN, or cancels pattern end output.

## Program Performance

<b>Number of patterns</b>	10 patterns (Linkable)
<b>Number of steps</b>	100 (10 steps/pattern)
<b>Number of repetitions</b>	0 to 10000 times (Repetitions disabled when set to 0)
<b>Program time range</b>	0 to 99 hours 59 minutes/step, or 0 to 99 minutes 59 seconds/step (When - - - - is set: Fixed value control is performed using step SV.)
<b>Wait value</b>	Thermocouple, RTD inputs: 0 to 20% of input span DC voltage, current input: 0 to 20% of scaling span (The placement of the decimal point follows the selection.) (The Wait function is disabled when set to 0 or 0.0.)

## Control Performance

<b>Control action</b>	<ul style="list-style-type: none"> <li>• PID control action (with AT function)</li> <li>• PI control action (When derivative time is set to 0.)</li> <li>• PD control action (When integral time is set to 0.)</li> <li>• P control action (When integral and derivative time are set to 0.)</li> <li>• ON/OFF control action (When proportional band is set to 0 or 0.0.)</li> </ul>
<b>OUT1 proportional band (P)</b>	Thermocouple, RTD input without decimal point: 0 to Input span°C (°F) Thermocouple, RTD input with decimal point: 0.0 to Input span°C (°F) DC voltage, current inputs: 0.0 to 1000.0% (ON/OFF control action when set to 0 or 0.0.)
<b>Integral time (I)</b>	0 to 3600 sec (Setting the value to 0 disables the function.)
<b>Derivative time (D)</b>	0 to 1800 sec (Setting the value to 0 disables the function.)
<b>OUT1 proportional cycle</b>	0.5, 1 to 120 sec
<b>ARW</b>	0 to 100%
<b>OUT1 ON/OFF hysteresis</b>	0.1 to 1000.0°C (°F) DC voltage, current inputs: 1 to 10000 (The placement of the decimal point follows the selection.)
<b>OUT1 high limit, OUT1 low limit</b>	0 to 100% (Direct current output: -5 to 105%)

## Standard Function

<b>Wait function</b>	During program control, the program does not proceed to the next step until the deviation between PV and SV enters $SV \pm \text{Wait}$ value at the end of step. The PV Display and PTN/STEP Display flash while the Wait function is working.
<b>Program control Hold function</b>	During program control RUN, progress of current step can be suspended. During program control RUN, if the  key is pressed for approx. 1 second, the Program control Hold function is enabled. While the Program control Hold function is working, the PV Display and RUN indicator flash. Pressing the <b>RUN</b> key cancels suspension, and program control resumes.
<b>Advance function</b>	Interrupts current step during program control RUN, and proceeds to the beginning of the next step. During program control RUN, if the <b>RUN</b> key is pressed for approx. 1 second, the Advance function is enabled.
<b>Pattern link and repetitions function</b>	Patterns 1 to 10 can be linked to the next pattern (of each pattern). For Pattern 10, Pattern 1 can be linked. Number of repetitions for Patterns 1 to 10: 0 to 10000 times. For repetitions of linked patterns, the whole linked pattern will be repeated as many times as set for the former pattern.
<b>Step SV when program control starts</b>	Program control starts from the step SV set in [Step SV when program control starts].



<b>Program control start type</b>	<p>Selects program control start type.</p> <p>PV start: Only when program control starts, the step SV is advanced to the PV, then program control starts.</p> <p>PVR start: When program control starts and in pattern repeating, the step SV is advanced to the PV, then program control starts.</p> <p>SV start: Program control starts from the step SV which has been set in [Step SV when program control starts].</p>
<b>Power restore action</b>	<p>If power fails during program control RUN, the controller can be operated depending on the selection in [Power restore action].</p> <p>Stops after power is restored: Stops current program control, and returns to Program control STOP (in Standby).</p> <p>Continues after power is restored: Continues (Resumes) previous program control after power is restored.</p> <p>Suspends after power is restored: Suspends (on hold) current program control, and performs control using the step SV from the point of suspension. Pressing the <b>RUN</b> key cancels suspension, and program control resumes.</p> <p>Progressing time error when power is restored: 1 minute or 1 second</p>
<b>Step time speed-up function</b>	<p>During program control RUN, makes step time progress 60 times faster while the <b>FAST</b> key is pressed.</p> <p>If the Wait function is set, the Wait function has priority.</p>
<b>Event output EV1</b>	<p>Output turns ON or OFF, depending on Event condition selected in [Event output EV1 allocation]:</p> <p>Alarm output, Heater burnout alarm output, Loop break alarm output, Time signal output, Output during AT, Pattern end output, Output by communication command, RUN output</p>
<b>Alarm action</b>	<p>Selects any alarm action in [Event output EV□ allocation] from the following:</p> <p>High limit alarm, Low limit alarm, High/Low limits alarm, High/Low limits independent alarm, High/Low limit range alarm, High/Low limit range independent alarm, Process high alarm, Process low alarm, High limit with standby alarm, Low limit with standby alarm, High/Low limits with standby alarm, High/Low limits with standby independent alarm</p> <p>Alarm Energized/De-energized action are applied to the above alarms, totaling 24 alarm types. No alarm action can also be selected.</p>
<b>Set value</b>	Factory default value: 0
<b>Action</b>	ON/OFF action
<b>Alarm hysteresis</b>	0.1 to 1000.0°C (°F) DC voltage, current input: 1 to 10000 (The placement of the decimal point follows the selection.)
<b>Output</b>	EV□ output for which Alarm output (001 to 012) is selected in [Event output EV□ allocation].

<b>Loop break alarm</b>	When Loop break alarm is selected in [Event output EV□ allocation], detects actuator trouble (heater burnout, heater adhesion) or sensor burnout.
<b>Loop break alarm time</b>	0 to 200 minutes
<b>Loop break alarm span</b>	Thermocouple, RTD input without decimal point: 0 to 150°C (°F) Thermocouple, RTD input with decimal point: 0.0 to 150.0°C (°F) DC voltage, current input: 0 to 1500 (The placement of the decimal point follows the selection.)
<b>Output</b>	EV□ output for which Loop break alarm output is selected in [Event output EV□ allocation].
<b>Time signal output</b>	When Time signal output is selected in [Event output EV□ allocation], Time signal output activates during Time signal output ON time within one pattern total time. Time signal output ON time follows Time signal output OFF time after the program control starts. During Wait action or Program control Hold, progress time of Time signal output stops. When step time is changed during program control RUN, Time signal output timing is re-calculated using the pattern time after change.
<b>Output during AT</b>	When 'Output during AT' is selected in [Event output EV□ allocation], turns ON during AT.
<b>Pattern end output</b>	When Pattern end output is selected in [Event output EV□ allocation], Pattern end output is turned ON during Pattern end output time after program control is finished, and the SV Display flashes <b>P E n d</b> . By pressing the <b>STOP</b> key for approximately 1 second, Pattern end output is turned OFF, and the unit returns to Program control STOP (in Standby). If Pattern end output time is set, Pattern end output is automatically turned OFF after Pattern end output time has expired. The unit returns to Program control STOP (in Standby).
<b>RUN output</b>	When 'RUN output' is selected in [Event output EV□ allocation], turns ON during program control RUN.
<b>Data clear function</b>	During program control STOP (in Standby), if the <b>▲</b> , <b>▼</b> and <b>STOP</b> keys (in that order) are pressed together for approx. 3 seconds, the PV Display indicates <b>CL R</b> , and the unit enters [Data clear Yes/No]. Select <b>YES</b> (Data clear Yes), and press the <b>MODE</b> key. The PV Display indicates <b>! 0 !</b> for approx. 3 seconds, and all data will return to factory default values.

## Attached Functions

<b>Sensor correction coefficient</b>	Sets slope of input value from a sensor.
<b>Sensor correction</b>	Corrects the input value from a sensor.
<b>Set value lock</b>	Locks the set values to prevent setting errors.
<b>Power failure countermeasure</b>	The setting data is backed up in the non-volatile IC memory.
<b>Self-diagnosis</b>	The CPU is monitored by a watchdog timer, and if an abnormal status occurs, the controller is switched to warm-up status, turning all outputs OFF.
<b>Automatic cold junction temperature compensation</b>	Detects the temperature at the connection terminal between the thermocouple and the instrument, and maintains it at the same status as if the reference junction location temperature were at 0°C (32°F).
<b>Indication range, Control range</b>	<p>Thermocouple input:            [Input range low limit value – 50°C (100°F)] to            [Input range high limit value + 50°C (100°F)]</p> <p>RTD input:            [Input range low limit value – (Input span x 1%)] to            [Input range high limit value + 50°C (100°F)]</p> <p>DC voltage, current inputs:            [Scaling low limit value – (Scaling span x 1%)] to            [Scaling high limit value + (Scaling span x 10%)]</p>
Input error (Overscale, Underscale)	<p>If input errors (overscale, underscale) occur, the following will be performed depending on the selection in [Error indication].</p> <p><b>If 'Disabled' is selected in [Error indication]:</b></p> <p>Overscale occurs if PV has exceeded Input range high limit value (Scaling high limit value for DC voltage, current inputs). The PV Display indicates PV.</p> <p>Underscale occurs if PV has dropped below Input range low limit value (Scaling low limit value for DC voltage, current inputs). The PV Display indicates PV.</p> <p><b>If 'Enabled' is selected in [Error indication]:</b></p> <p>Overscale occurs if PV has exceeded Input range high limit value (Scaling high limit value for DC voltage, current inputs). The PV Display indicates the PV and error code <math>E\text{-}OS</math> alternately.</p> <p>Underscale occurs if PV has dropped below Input range low limit value (Scaling low limit value for DC voltage, current inputs). The PV Display indicates the PV and error code <math>E\text{-}OE</math> alternately.</p>

## Burnout

If burnout occurs, the following will be performed depending on the selection in [Error indication].

### If Disabled is selected in [Error indication]:

If PV has exceeded Indication range and Control range, the PV Display flashes  $\overline{\text{---}}$ . OUT1 and OUT2 are turned OFF (OUT1 low limit value for direct current output, OUT2 low limit value for DA, EV3DA).

If PV has dropped below Indication range and Control range, the PV Display flashes  $\text{---}$ . OUT1 and OUT2 are turned OFF (OUT1 low limit value for direct current output, OUT2 low limit value for DA, EV3DA).

If thermocouple or RTD input is burnt out, or if DC voltage (0 – 1 V DC) input is disconnected, the PV Display flashes  $\text{---}$ .

If the following DC voltage or current input is disconnected:

4 – 20 mA DC, 1 – 5 V DC inputs: The PV Display flashes  $\text{---}$ .

0 – 20 mA DC, 0 – 5 V DC, 0 – 10 V DC inputs: The PV Display indicates the value corresponding with 0 mA DC or 0 V DC input.

If Alarm output, Heater burnout alarm output or Loop break alarm output is selected in [Event output EV allocation], Event output will be turned ON under the alarm active conditions.

Burnout is enabled even in Program control STOP (in Standby) status. However, Event output is not turned ON.

[Output status when input errors occur] can be used only for controllers using direct current and voltage inputs, and direct current output.

Output status differs depending on selection in [Output status when input errors occur].

Output status when input errors occur	Contents, Indication	Output Status			
		OUT1		OUT2	
		Direct (Cooling) action	Reverse (Heating) action	Direct (Cooling) action	Reverse (Heating) action
$\text{on}$	[ $\overline{\text{---}}$ ] flashes.	ON (20mA) or OUT1 high limit value (*)	OFF (4mA) or OUT1 low limit value	OFF or OUT2 low limit value	ON or OUT2 high limit value (*)
$\text{off}$		OFF (4mA) or OUT1 low limit value			OFF or OUT2 low limit value
$\text{on}$	[ $\text{---}$ ] flashes.	OFF (4mA) or OUT1 low limit value	ON (20mA) or OUT1 high limit value (*)	ON or OUT2 high limit value (*)	OFF or OUT2 low limit value
$\text{off}$			OFF (4mA) or OUT1 low limit value	OFF or OUT2 low limit value	

(\*) Outputs a value between OFF (4mA) and ON (20mA) or between OUT1 (or OUT2) low limit value and OUT1 (or OUT2) high limit value, depending on deviation.

### If Enabled is selected in [Error indication]:

If PV has exceeded Indication range and Control range, the PV Display indicates  $\overline{\text{---}}$  and  $\text{Er-07}$  alternately. OUT1 and OUT2 are turned OFF (OUT1 low limit value for direct current output, OUT2 low limit value for DA, EV3DA).

If PV has dropped below Indication range and Control range, the PV Display indicates  $\text{---}$  and  $\text{Er-07}$  alternately. OUT1 and OUT2 are turned OFF (OUT1 low limit value for direct current output, OUT2 low limit value for DA, EV3DA).

If thermocouple, RTD or DC voltage (0 to 1 V DC) input is burnt out or disconnected, the PV Display indicates  $\text{---}$  and  $\text{Er-07}$  alternately.

If the following DC voltage or current input is disconnected:

4 – 20 mA DC, 1 – 5 V DC inputs: The PV Display indicates  $\text{---}$  and  $\text{Er-07}$  alternately.

0 – 20 mA DC, 0 – 5 V DC, 0 – 10 V DC inputs: The PV Display indicates the value corresponding with 0 mA DC or 0 V DC input.

If Alarm output, Heater burnout alarm output or Loop break alarm output is selected in [Event output EV□ allocation], Event output will be turned ON under the alarm active conditions.

Burnout is enabled even in Program control STOP (in Standby) status. However, Event output is not turned ON.

[Output status when input errors occur] can be used only for controllers using direct current and voltage inputs, and direct current output.

Output status differs depending on selection in [Output status when input errors occur].

Output status when input errors occur	Contents, Indication	Output Status			
		OUT1		OUT2	
		Direct (Cooling) action	Reverse (Heating) action	Direct (Cooling) action	Reverse (Heating) action
ON□□	Indicates [ - - - - ] and [Err□□] alternately.	ON (20mA) or OUT1 high limit value (*)	OFF (4mA) or OUT1 low limit value	OFF or OUT2 low limit value	ON or OUT2 high limit value (*)
OFF□□		OFF (4mA) or OUT1 low limit value			OFF or OUT2 low limit value
ON□□	Indicates [ - - - - ] and [Err□□] alternately.	OFF (4mA) or OUT1 low limit value	ON (20mA) or OUT1 high limit value (*)	ON or OUT2 high limit value (*)	OFF or OUT2 low limit value
OFF□□			OFF (4mA) or OUT1 low limit value	OFF or OUT2 low limit value	

(\*) Outputs a value between OFF (4mA) and ON (20mA) or between OUT1 (or OUT2) low limit value and OUT1 (or OUT2) high limit value, depending on deviation.

<b>Warm-up indication</b>	After the power supply to the instrument is turned on, the PV Display indicates the input type, and SV Display indicates input range high limit value (for thermocouple, RTD inputs) or scaling high limit value (for direct current and voltage inputs) for approximately 3 seconds. Control output is OFF (0 mA for direct current output), and Transmission output is 0 mA.
<b>Console communication</b>	By connecting to the tool cable (CMD-001, sold separately) to the tool cable connector, the following operations can be conducted from an external computer, using the Console software SWC-PCB101M. Console communication and Serial communication (C5W, C5 options) cannot be used together. (1) Reading and writing of step SV, step time, PID and various set values (2) Reading of PV and action status (3) Function change Communication line: TTL level

**Other**

<b>Accessories included</b>	Mounting bracket: 1 set Instruction manual (excerpt): 1 copy
<b>Accessories sold separately</b>	Terminal cover CT (Current transformer): CTL-6-S-H (For Heater burnout alarm output 20 A) CTL-12-S36-10L1U (For Heater burnout alarm output 100 A) Tool cable CMD-001

## 11.2 Optional Specifications

<b>Event output EV2</b> [EV2, EV3(DR) options]	Output will be turned ON or OFF depending on the Event conditions selected in [Event output EV2 allocation]. One output can be selected from the following: Alarm output, Heater burnout alarm output, Loop break alarm output, Time signal output, Output during AT, Pattern end output, Output by communication command, RUN output, Heating/Cooling control Relay contact output
<b>Heating/Cooling control output</b> [EV2(DR), DS, DA, EV3D□ options]	Performs Heating/Cooling control.
<b>OUT2 proportional band</b>	Thermocouple, RTD inputs without decimal point: 0 to Input span°C (°F) Thermocouple, RTD inputs with decimal point: 0.0 to Input span°C (°F) DC voltage, current inputs: 0.0 to 1000.0% (ON/OFF control when set to 0.0)
<b>Integral time (I)</b>	0 to 3600 seconds (Setting to 0 disables the function.) (Same as OUT1 integral time)
<b>Derivative time (D)</b>	0 to 1800 seconds (Setting to 0 disables the function.) (Same as OUT1 derivative time)
<b>OUT2 proportional cycle</b>	0.5, 1 to 120 seconds
<b>Overlap/Dead band</b>	Thermocouple, RTD inputs: -200.0 to 200.0°C (°F) DC voltage, current inputs: -2000 to 2000 (The placement of the decimal point follows the selection.)
<b>OUT2 ON/OFF hysteresis</b>	Thermocouple, RTD inputs: 0.1 to 1000.0°C (°F) DC voltage, current inputs 1 to 10000 (The placement of the decimal point follows the selection.)
<b>OUT2 high limit, OUT2 low limit</b>	0 to 100% (DA, EV3DA: -5 to 105%)
<b>OUT2 cooling method</b>	(1) Air cooling (linear characteristics), (2) Oil cooling (1.5th power of the linear characteristics) (3) Water cooling (2nd power of the linear characteristics)
<b>Insulated power output</b> (P24 option)	
<b>Output voltage</b>	24 ± 3 V DC (when load current is 30 mA DC)
<b>Ripple voltage</b>	Within 200 mV DC (when load current is 30 mA DC)
<b>Max. load current:</b>	30 mA DC
<b>Event output EV3</b> (EV3D□, EI options)	Output will be turned ON or OFF depending on the Event conditions selected in [Event output EV3 allocation]. One output can be selected from the following: Alarm output, Heater burnout alarm output, Loop break alarm output, Time signal output, Output during AT, Pattern end output, Output by communication command, RUN output
<b>Serial communication</b> (C5W, C5 options)	The following operations can be carried out from an external computer. (1) Reading and writing of the step SV, step time, PID values and various set values (2) Reading of the PV and action status (3) Function change
<b>Communication line</b>	EIA RS-485
<b>Communication method</b>	Half-duplex communication
<b>Communication speed</b>	9600, 19200, 38400 bps (Selectable by keypad)
<b>Synchronization method</b>	Start-stop synchronization

<b>Communication protocol</b>	Shinko protocol, SV digital transmission, SV digital reception, Modbus ASCII mode, Modbus RTU mode (Selectable by keypad) Communication converter IF-400 is available for Shinko protocol and Modbus protocol.			
<b>Data bit/Parity</b>	Data bit: 7, 8 Parity: Even, Odd, No parity (Selectable by keypad)			
<b>Stop bit:</b>	1, 2 (Selectable by keypad)			
<b>Data format</b>	<b>Communication Protocol</b>	<b>Shinko Protocol</b>	<b>Modbus ASCII</b>	<b>Modbus RTU</b>
	Start bit	1	1	1
	Data bit	7 (8) Selectable	7 (8) Selectable	8
	Parity	Even (No parity, Odd) Selectable	Even (No parity, Odd) Selectable	No parity (Even, Odd) Selectable
	Stop bit	1 (2) Selectable	1 (2) Selectable	1 (2) Selectable
<b>Response delay time</b>	Response from the controller can be delayed after receiving command from the host computer. If Response delay time is changed via software communication, the changed delay time will be reflected from that response data. • Setting range: 0 to 1000 ms			

**SV digital transmission**

When 'SV digital transmission (Shinko protocol)' is selected in [Communication protocol], step SV can be digitally transmitted by connecting to Shinko digital indicating controllers with C5 option (SV digital transmission).

When 'SV digital reception (Shinko protocol)' is selected in [Communication protocol], step SV can be received via SVTC command by connecting to Shinko programmable controllers.

Shinko programmable controllers:

- PC-900 with the SVTC (SV digital transmission) option
- PCD-33A with the SVTC (SV digital transmission) option
- PCA1 for which 'SV digital transmission' is selected in [Communication protocol]
- PCB1 for which 'SV digital transmission' is selected in [Communication protocol]

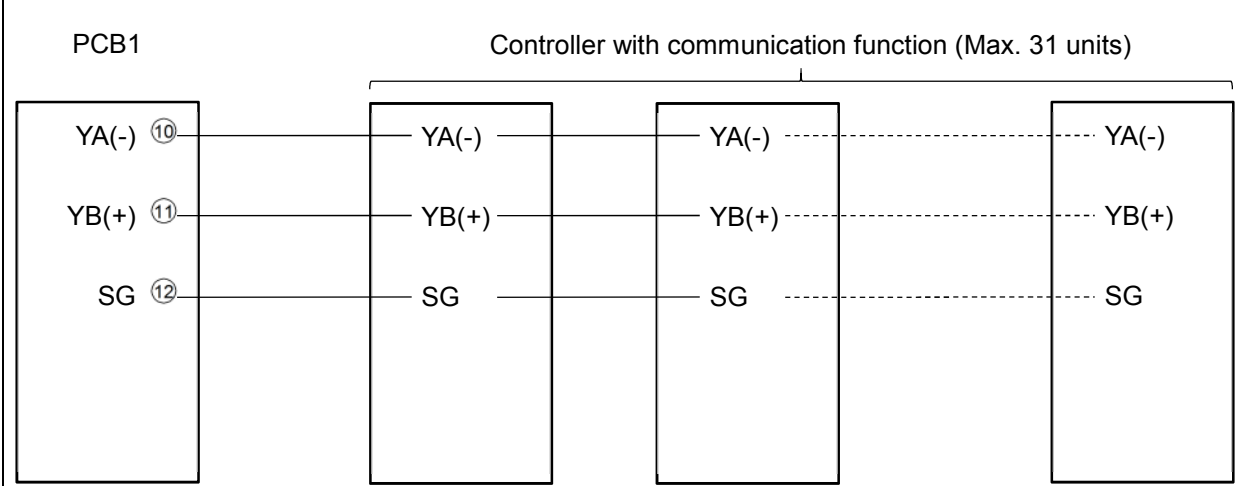

(Fig. 11.2-1)

<b>Heater burnout alarm</b> (C5W, EIW, W options)	Monitors heater current with CT (current transformer), and detects heater burnout. EV <input type="checkbox"/> output, for which Heater burnout alarm is selected in [Event output EV <input type="checkbox"/> allocation], will be turned ON or OFF. This alarm is also activated when the input is burnt out.
<b>Rated current:</b>	20 A, 100 A (Must be specified when ordering.) Single-phase: Detects burnout with CT1 input. 3-phase: Detects burnout with CT1 and CT2 inputs.
<b>Setting accuracy</b>	±5% of the rated value
<b>Transmission output</b> (EIT option)	Converting the value (PV, SV or MV transmission) to analog signal every 125 ms, outputs the value in current. Outputs Transmission output low limit value if Transmission output high limit and low limit value are the same. If SV or MV transmission is selected, 4 mA is output during Program control STOP (in Standby).
<b>Event input</b> (C5W, EIW, EIT, C5, EI options)	Action can be switched by event conditions selected in [Event input DI <input type="checkbox"/> allocation]. One function can be selected from the following: Pattern number selection, Direct/Reverse action, Program control RUN/STOP, Program control Holding/Not holding, Program control Advance function Signal edge action from OFF to ON / ON to OFF is engaged. However, when power is turned ON, level action is engaged except Program control Advance function.



## 12. Troubleshooting



### Warning

Turn the power supply to the instrument off before wiring or checking. Working on or touching the terminal with the power switched on may result in severe injury or death due to electrical shock.

Moreover, the instrument must be grounded before the power supply to the instrument is turned on.

If any malfunctions occur, refer to the following items after checking that power is being supplied to the controller.

#### 12.1 Indication

Problem	Possible Cause	Solution
The PV Display indicates $E-01$ .	Internal non-volatile IC memory is defective.	Cancel the error code by pressing the <b>MODE</b> key, and perform data clearing.(p.85) If the problem is not still solved after power is turned ON again, contact our agency or us.
The PV Display indicates $E-02$ .	Data writing (in non-volatile IC memory) error when power failure occurs.	Cancel the error code by pressing the <b>MODE</b> key, and perform data clearing. (P.85)
The PV Display indicates PV and $E-05$ (*) alternately.	Overscale. PV has exceeded Input range high limit value (scaling high limit value for DC voltage, current inputs).	Check the input signal source.
The PV Display indicates PV and $E-06$ (*) alternately.	Underscale. PV has dropped below Input range low limit value (scaling low limit value for DC voltage, current inputs).	Check the input signal source and wiring of input terminals.
The PV Display flashes $----$ .	PV has exceeded the Indication range and Control range.	Check the input signal source.
The PV Display indicates $----$ and $E-07$ (*) alternately.	Burnout of thermocouple, RTD or disconnection of DC voltage (0 to 1 V DC)	Replace each sensor. <b>How to check whether the sensor is burnt out:</b> <b>[Thermocouple]</b> If the input terminals of the instrument are shorted, and if a value around room temperature is indicated, the instrument is likely to be operating normally, however, the sensor may be burnt out. <b>[RTD]</b> If approx. 100 $\Omega$ of resistance is connected to the input terminals between A-B of the instrument and between B-B is shorted, and if a value around 0°C (32°F) is indicated, the instrument is likely to be operating normally, however, the sensor may be burnt out. <b>[DC voltage (0 to 1 V DC)]</b> If the input terminals of the instrument are shorted, and if a scaling low limit value is indicated, the instrument is likely to be operating normally, however, the signal wire may be disconnected.

(\*) Available when 'Enabled' is selected in [Error indication].

Problem	Possible Cause	Solution
	Check whether the input terminals of thermocouple, RTD or DC voltage (0 to 1 V DC) are securely mounted to the instrument input terminals.	Connect the sensor terminals to the instrument input terminals securely.
The PV Display flashes [ _ _ _ _ ].	PV has dropped below the Indication range and Control range.	Check the input signal source and wiring of input terminals.
The PV Display indicates [ _ _ _ _ ] and [Err 07] (*) alternately.	Check whether input signal wire for direct current (4 to 20 mA DC) or DC voltage (1 to 5 V DC) is disconnected.	<b>How to check whether the input signal wire is disconnected:</b> <b>[Direct current (4 to 20 mA DC)]</b> If the input to the input terminals of the instrument is 4 mA DC and if a scaling low limit value is indicated, the instrument is likely to be operating normally, however, the signal wire may be disconnected. <b>[DC voltage (1 to 5 V DC)]</b> If the input to the input terminals of the instrument is 1 V DC and if a scaling low limit value is indicated, the instrument is likely to be operating normally, however, the signal wire may be disconnected.
	Check whether input signal wire for direct current (4 to 20 mA DC) or DC voltage (1 to 5 V DC) is securely connected to the instrument input terminals.	Connect the input signal wire to the terminals of this instrument securely.
	Check if polarity of thermocouple or compensating lead wire is correct. Check whether codes (A, B, B) of RTD agree with the instrument terminals.	Wire them correctly.
The PV Display indicates [Err 10].	Hardware malfunction	Contact our agency or us.
The indication of PV Display is irregular or unstable.	Check whether sensor input or temperature unit (°C or °F) is correct.	Select the sensor input and temperature unit (°C or °F) correctly.
	Sensor correction coefficient or Sensor correction value is unsuitable.	Set them to suitable values.
	Check whether the sensor specification is correct.	Use a sensor with appropriate specifications.
	AC leaks into the sensor circuit.	Use an ungrounded type sensor.

(\*) Available when 'Enabled' is selected in [Error indication].

Problem	Possible Cause	Solution
The PV Display keeps indicating the value set in [Scaling low limit].	Check whether the input signal wire for direct current (0 to 20 mA DC) and DC voltage (0 to 5 V DC, 0 to 10 V DC) is disconnected.	Check the input signal wires of direct current (0 to 20 mA DC) and DC voltage (0 to 5 V DC, 0 to 10 V DC). <b>How to check whether the input signal wire is disconnected:</b> <b>[Direct current (0 to 20 mA DC)]</b> If the input to the input terminal of this controller is 4 mA DC, and if a value (converted value from scaling high, low limit setting) corresponding to 4 mA DC is indicated, the controller is likely to be operating normally, however, the input signal wire may be disconnected. <b>[DC voltage (0 to 5 V DC, 0 to 10 V DC)]</b> If the input to the input terminal of this controller is 1 V DC, and if a value (converted value from scaling high, low limit setting) corresponding to 1 V DC is indicated, the controller is likely to be operating normally, however, the input signal wire may be disconnected.
	Check whether the input terminals for direct current (0 to 20 mA DC) or DC voltage (0 to 5 V DC, 0 to 10 V DC) are securely connected to the instrument input terminals.	Connect the input terminals of direct current or DC voltage to the input terminals of this instrument securely.

## 12.2 Key Operation

Problem	Possible Cause	Solution
The following values cannot be set: Step SV, step time, OUT1 proportional band, EV□ alarm value, etc.	Set value lock (Lock 1 or Lock 4) is selected.	Release the lock in [Set value lock].
	AT is performing.	Cancel AT.
Only step SV, step time and EV □ Alarm value can be set. Other settings are not possible.	Set value lock (Lock 2 or Lock 5) is selected.	Release the lock in [Set value lock].
The setting indication does not change in the input range, and new values are unable to be set.	Scaling high or low limit value may be set at the point where the value does not change.	Set it to a suitable value.
A pattern number cannot be selected by the <b>PTN</b> key.	A pattern number might be selected by means of Event input. The pattern number selected via Event input has priority over a pattern number selected by the <b>PTN</b> key.	Open (OFF) the SG terminal and any one terminal of Event input (DI1, DI2).

### 12.3 Control

Problem	Possible Cause	Solution
Even though program control is executed, the control is advanced and the program is finished soon.	The step time of the performing pattern number is set to 00:00.	Set the step time to a suitable value.
Step does not progress.	Program control is suspended (Hold function). While program control is suspended, the PV Display and RUN indicator flash.	Press the <b>RUN</b> key. Suspension of control will be cancelled, and program control will resume.
	The Wait function is working. If the Wait function works, the PV Display and PTN/STEP Display flash.	Press the <b>RUN</b> key for approx. 1 second to cancel the Wait function. The Wait function will be cancelled, and program control will continue.
PV does not rise or fall.	Sensor is out of order.	Replace the sensor.
	Check whether the sensor or control output terminals are securely mounted to the instrument input terminals.	Ensure that the sensor or control output terminals are mounted to the instrument input terminals securely.
	Check whether the wiring of sensor or control output terminals is correct.	Wire them correctly.
Control output OUT1 or OUT2 remains in an ON status.	OUT1 or OUT2 low limit value is set to 100% or higher.	Set it to a suitable value.
The control output OUT1 or OUT2 remains in an OFF status.	OUT1 or OUT2 high limit value is set to 0% or less.	Set it to a suitable value.
The PV Display indicates <b>E-20</b>	AT has not been completed even if approx. 4 hours have elapsed since AT started.	Manually set P, I, D and ARW values.

# 13. Character Table

## • Explanation of Setting Item

Upper left: PV Display

Indicates setting item characters.

Lower left: PTN/STEP Display, SV Display

The PTN/STEP Display indicates the selected pattern number, and indication is different depending on the setting item.

The SV Display indicates factory default.

Right side: Indicates the setting item, explanation of its function, and setting range.

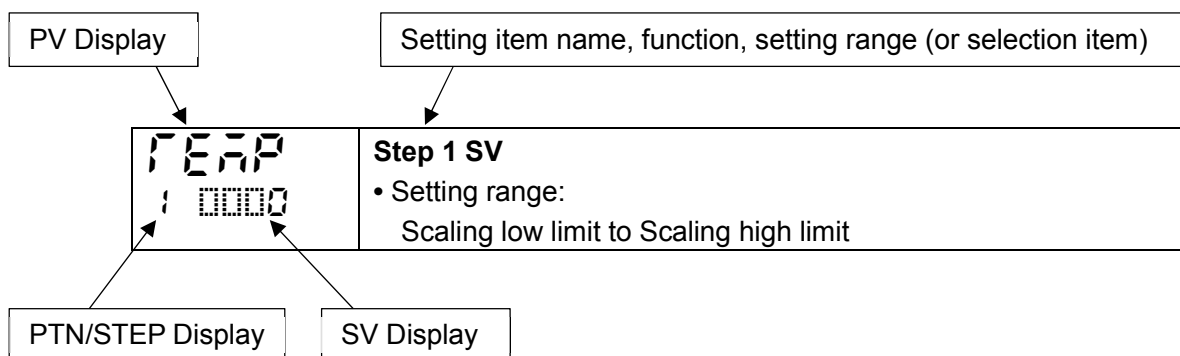

## 13.1 Error Code









Error codes are indicated on the PV Display.

Error Code	Error Contents	Occurrence
E-01 1 0500(*1)	Internal non-volatile IC memory (EEPROM) is defective.	When power is turned ON
E-02 1 0500(*1)	Data writing error when power failure occurs.	When power is turned ON
E-05 1 0500(*2)	PV has exceeded Input range high limit value (Scaling high limit value for DC voltage, current inputs).	When operating
E-06 1 0500(*2)	PV has dropped below Input range low limit value (Scaling low limit value for DC voltage, current inputs).	When operating
E-07 1 0500(*2)	Input burnout or disconnection. Input value is outside of the Indication range and Control range.	When operating
E-10 1 0500	Hardware malfunction or errors (This error cannot be cancelled.)	When operating
E-20 1 0500(*1)	AT has not been completed even if approx. 4 hours have elapsed since AT started. When input errors have occurred.	After AT starts

(\*1) Can be cancelled by the **MODE** key.

(\*2) An error code is indicated when Enabled is selected in [Error indication].

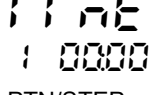
### 13.2 Pattern Setting Mode

Characters, Factory Default	Setting Item, Setting Range	Data
 PTN/STEP indicator 1 lights.	<b>Step 1 SV</b> Scaling low limit to Scaling high limit	
 PTN/STEP indicator 1 lights.	<b>Step 1 time</b> - - - - , 00:00 to 99.59 (Time unit follows the selection in [Step time unit].) If the <input type="checkbox"/> key is pressed at 00:00, - - - - will be indicated. If - - - - is set, Fixed value control will be performed using Step 1 SV.	
 PTN/STEP indicator 1 lights.	<b>Step 1 PID block number</b> 1 to 10	
 PTN/STEP indicator 2 lights.	<b>Step 2 SV</b> Scaling low limit to Scaling high limit	
 PTN/STEP indicator 2 lights.	<b>Step 2 time</b> - - - - , 00:00 to 99.59 (Time unit follows the selection in [Step time unit].) If the <input type="checkbox"/> key is pressed at 00:00, - - - - will be indicated. If - - - - is set, Fixed value control will be performed using Step 2 SV.	
 PTN/STEP indicator 2 lights.	<b>Step 2 PID block number</b> 1 to 10	
 PTN/STEP indicator 3 lights.	<b>Step 3 SV</b> Scaling low limit to Scaling high limit	
 PTN/STEP indicator 3 lights.	<b>Step 3 time</b> - - - - , 00:00 to 99.59 (Time unit follows the selection in [Step time unit].) If the <input type="checkbox"/> key is pressed at 00:00, - - - - will be indicated. If - - - - is set, Fixed value control will be performed using Step 3 SV.	
 PTN/STEP indicator 3 lights.	<b>Step 3 PID block number</b> 1 to 10	

Characters, Factory Default	Setting Item, Setting Range	Data
 PTN/STEP indicator 4 lights.	<b>Step 4 SV</b> Scaling low limit to Scaling high limit	
 PTN/STEP indicator 4 lights.	<b>Step 4 time</b> -----, 00:00 to 99.59 (Time unit follows the selection in [Step time unit].) If the <input type="checkbox"/> key is pressed at 00:00, ----- will be indicated. If ----- is set, Fixed value control will be performed using Step 4 SV.	
 PTN/STEP indicator 4 lights.	<b>Step 4 PID block number</b> 1 to 10	
 PTN/STEP indicator 5 lights.	<b>Step 5 SV</b> Scaling low limit to Scaling high limit	
 PTN/STEP indicator 5 lights.	<b>Step 5 time</b> -----, 00:00 to 99.59 (Time unit follows the selection in [Step time unit].) If the <input type="checkbox"/> key is pressed at 00:00, ----- will be indicated. If ----- is set, Fixed value control will be performed using Step 5 SV.	
 PTN/STEP indicator 5 lights.	<b>Step 5 PID block number</b> 1 to 10	
 PTN/STEP indicator 6 lights.	<b>Step 6 SV</b> Scaling low limit to Scaling high limit	
 PTN/STEP indicator 6 lights.	<b>Step 6 time</b> -----, 00:00 to 99.59 (Time unit follows the selection in [Step time unit].) If the <input type="checkbox"/> key is pressed at 00:00, ----- will be indicated. If ----- is set, Fixed value control will be performed using Step 6 SV.	
 PTN/STEP indicator 6 lights.	<b>Step 6 PID block number</b> 1 to 10	















Characters, Factory Default	Setting Item, Setting Range	Data
 PTN/STEP indicator 7 lights.	<b>Step 7 SV</b> Scaling low limit to Scaling high limit	
 PTN/STEP indicator 7 lights.	<b>Step 7 time</b> ----, 00:00 to 99.59 (Time unit follows the selection in [Step time unit].) If the <input type="checkbox"/> key is pressed at 00:00, ---- will be indicated. If ---- is set, Fixed value control will be performed using Step 7 SV.	
 PTN/STEP indicator 7 lights.	<b>Step 7 PID block number</b> 1 to 10	
 PTN/STEP indicator 8 lights.	<b>Step 8 SV</b> Scaling low limit to Scaling high limit	
 PTN/STEP indicator 8 lights.	<b>Step 8 time</b> ----, 00:00 to 99.59 (Time unit follows the selection in [Step time unit].) If the <input type="checkbox"/> key is pressed at 00:00, ---- will be indicated. If ---- is set, Fixed value control will be performed using Step 8 SV.	
 PTN/STEP indicator 8 lights.	<b>Step 8 PID block number</b> 1 to 10	
 PTN/STEP indicator 9 lights.	<b>Step 9 SV</b> Scaling low limit to Scaling high limit	
 PTN/STEP indicator 9 lights.	<b>Step 9 time</b> ----, 00:00 to 99.59 (Time unit follows the selection in [Step time unit].) If the <input type="checkbox"/> key is pressed at 00:00, ---- will be indicated. If ---- is set, Fixed value control will be performed using Step 9 SV.	
 PTN/STEP indicator 9 lights.	<b>Step 9 PID block number</b> 1 to 10	



Characters, Factory Default	Setting Item, Setting Range	Data	
<b>TEAP</b> 1 0000 PTN/STEP indicator 10 lights.	<b>Step 10 SV</b> Scaling low limit to Scaling high limit		
<b>TAE</b> 1 0000 PTN/STEP indicator 10 lights.	<b>Step 10 time</b> - - - - , 00:00 to 99.59 (Time unit follows the selection in [Step time unit].) If the <input type="checkbox"/> key is pressed at 00:00, - - - - will be indicated. If - - - - is set, Fixed value control will be performed using Step 10 SV.		
<b>PI d</b> 1 0001 PTN/STEP indicator 10 lights.	<b>Step 10 PID block number</b> 1 to 10		
<b>REP</b> 1 0000 PTN/STEP indicator turns off.	<b>Number of repetitions</b> 0 to 10000		
<b>CH n</b> 1 - - - - PTN/STEP indicator turns off.	<b>Pattern link</b>		
	- - - -		Pattern link Disabled
	<b>CH n</b>		Pattern link Enabled

### 13.3 Event Setting Mode

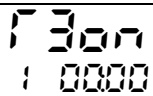
Characters, Factory Default	Setting Item, Setting Range	Data
<p>A 100 : 0000</p>	<p><b>EV1 alarm value</b>            High limit alarm                                 -(Input span) to Input span (*1)            Low limit alarm                                    -(Input span) to Input span (*1)            High/Low limits alarm                            0 to Input span (*1)            High/Low limits independent alarm            0 to Input span (*1)            High/Low limit range alarm                    0 to Input span (*1)            High/Low limit range independent alarm    0 to Input span (*1)            Process high alarm    Input range low limit to Input range high limit (*2)            Process low alarm    Input range low limit to Input range high limit (*2)            High limit with standby alarm                -(Input span) to Input span (*1)            Low limit with standby alarm                 -(Input span) to Input span (*1)            High/Low limits with standby alarm           0 to Input span (*1)            High/Low limits with standby independent alarm 0 to Input span (*1)</p> <p>(*1) For DC voltage, current inputs, the input span is the same as the scaling span.            (The placement of the decimal point follows the selection.)            (*2) For DC voltage, current inputs, input range low (or high) limit value is the same as scaling low (or high) limit value. (The placement of the decimal point follows the selection.)            Available when 000 1 (High limit alarm) to 00 12 (High/Low limits with standby independent alarm) is selected in [Event output EV1 allocation].</p>	
<p>A 140 : 0000</p>	<p><b>EV1 high limit alarm value</b>            Setting range: Same as those of EV1 alarm value.            Available when 0004 (High/Low limits independent alarm), 0005 (High/Low limit range independent alarm) or 00 12 (High/Low limits with standby independent alarm) is selected in [Event output EV1 allocation].</p>	
<p>F 10F : 0000</p>	<p><b>TS1 output OFF time</b>            Setting range:            00:00 to 99:59 (Time unit follows the selection in [Step time unit].)            Available when 00 15 (Time signal output) is selected in [Event output EV1 allocation].</p>	
<p>F 10n : 0000</p>	<p><b>TS1 output ON time</b>            Setting range:            00:00 to 99:59 (Time unit follows the selection in [Step time unit].)            Available when 00 15 (Time signal output) is selected in [Event output EV1 allocation].</p>	
<p>A200 : 0000</p>	<p><b>EV2 alarm value</b>            Setting range: Same as those of EV1 alarm value.            Available when 000 1 (High limit alarm) to 00 12 (High/Low limits with standby independent alarm) is selected in [Event output EV2 allocation].</p>	
<p>A240 : 0000</p>	<p><b>EV2 high limit alarm value</b>            Setting range: Same as those of EV1 alarm value.            Available when 0004 (High/Low limits independent alarm), 0005 (High/Low limit range independent alarm) or 00 12 (High/Low limits with standby independent alarm) is selected in [Event output EV2 allocation].</p>	

Characters, Factory Default	Setting Item, Setting Range	Data
	<b>TS2 output OFF time</b> Setting range: 00:00 to 99:59 (Time unit follows the selection in [Step time unit].) Available when  (Time signal output) is selected in [Event output EV2 allocation].	
	<b>TS2 output ON time</b> Setting range: 00:00 to 99:59 (Time unit follows the selection in [Step time unit].) Available when  (Time signal output) is selected in [Event output EV2 allocation].	
	<b>EV3 alarm value</b> Setting range: Same as those of EV1 alarm value. Available when  (High limit alarm) to  (High/Low limits with standby independent alarm) is selected in [Event output EV3 allocation].	
	<b>EV3 high limit alarm value</b> Setting range: Same as those of EV1 alarm value. Available when  (High/Low limits independent alarm),  (High/Low limit range independent alarm) or  (High/Low limits with standby independent alarm) is selected in [Event output EV3 allocation].	
	<b>TS3 output OFF time</b> Setting range: 00:00 to 99:59 (Time unit follows the selection in [Step time unit].) Available when  (Time signal output) is selected in [Event output EV3 allocation].	
	<b>TS3 output ON time</b> Setting range: 00:00 to 99:59 (Time unit follows the selection in [Step time unit].) Available when  (Time signal output) is selected in [Event output EV3 allocation].	







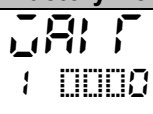
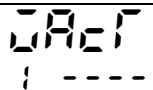
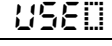

### 13.4 Control Parameter Setting Mode

Characters, Factory Default	Setting Item, Setting Range	Data
<b>AT</b> <b>00</b> <b>0</b> <b>----</b>	<b>AT Perform/Cancel</b>	
	<b>----</b>   AT Cancel	
	<b>AT</b> <b>00</b>   AT Perform	
<b>PbL</b> <b>0</b> <b>000</b> <b>1</b>	<b>PID block number</b> 1 to 10	
<b>P</b> <b>000</b> <b>1</b> <b>00</b> <b>10</b>	<b>OUT1 proportional band</b> Setting range: Thermocouple, RTD input without decimal point: 0 to input span°C (°F) Thermocouple, RTD input with decimal point: 0.0 to input span°C (°F) DC voltage, current inputs: 0.0 to 1000.0%	
<b>I</b> <b>000</b> <b>1</b> <b>0200</b>	<b>Integral time</b> Setting range: 0 to 3600 seconds	
<b>d</b> <b>000</b> <b>1</b> <b>0050</b>	<b>Derivative time</b> Setting range: 0 to 1800 seconds	
<b>Ar</b> <b>00</b> <b>1</b> <b>0050</b>	<b>ARW</b> Setting range: 0 to 100%	
<b>c</b> <b>000</b> <b>0</b> <b>0003</b>	<b>OUT1 proportional cycle</b> Setting range: 0.5, 1 to 120 seconds Available when OUT1 is relay contact output or non-contact voltage output type.	
<b>H</b> <b>50</b> <b>0</b> <b>00</b> <b>10</b>	<b>OUT1 ON/OFF hysteresis</b> Setting range: 0.1 to 1000.0°C (°F) DC voltage, current inputs: 1 to 10000 (The placement of the decimal point follows the selection.)	
<b>oL</b> <b>H0</b> <b>0</b> <b>0</b> <b>100</b>	<b>OUT1 high limit</b> Setting range: OUT1 low limit to 100% Direct current output type: OUT1 low limit to 105%	
<b>oL</b> <b>L0</b> <b>0</b> <b>0000</b>	<b>OUT1 low limit</b> Setting range: 0% to OUT1 high limit Direct current output type: -5% to OUT1 high limit	
<b>or</b> <b>Ar</b> <b>0</b> <b>0000</b>	<b>OUT1 rate-of-change</b> Setting range: 0 to 100 %/sec	
<b>c</b> <b>Ar</b> <b>L</b> <b>0</b> <b>Ar</b> <b>L0</b>	<b>OUT2 cooling method</b>	
	<b>Ar</b> <b>L0</b>   Air cooling (Linear characteristics)	
	<b>oL</b> <b>L0</b>   Oil cooling (1.5th power of the linear characteristics)	
	<b>o</b> <b>Ar</b> <b>L0</b>   Water cooling (2nd power of the linear characteristics)	
Available when EV2 option {0020 (Heating/Cooling control output) is selected in [Event output EV2 allocation]} is ordered, or when DS, DA or EV3D□ option is ordered.		

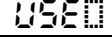
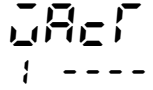
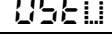
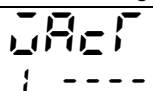
Characters, Factory Default	Setting Item, Setting Range	Data
P_b0 1 00 10	<b>OUT2 proportional band</b> Setting range: Thermocouple, RTD input without decimal point: 0 to Input span°C (°F) Thermocouple, RTD input with decimal point: 0.0 to Input span°C (°F) DC voltage, current inputs: 0.0 to 1000.0% Available when EV2 option {0020 (Heating/Cooling control output) is selected in [Event output EV2 allocation]} is ordered, or when DS, DA or EV3D□ option is ordered.	
c_b0 0 0003	<b>OUT2 proportional cycle</b> Setting range: 0.5, 1 to 120 seconds Available when EV2 option {0020 (Heating/Cooling control output) is selected in [Event output EV2 allocation]} is ordered, or when DS, EV3(DR), EV3DS option is ordered.	
H45b 0 00 10	<b>OUT2 ON/OFF hysteresis</b> Setting range: 0.1 to 1000.0°C (°F) DC voltage, current inputs: 1 to 10000 (The placement of the decimal point follows the selection.) Available when EV2 option {0020 (Heating/Cooling control output) is selected in [Event output EV2 allocation]} is ordered, or when DS, DA or EV3D□ option is ordered.	
oLHb 0 0 100	<b>OUT2 high limit</b> Setting range: OUT2 low limit value to 100% Direct current output type (DA, EV3DA options): OUT2 low limit value to 105% Available when EV2 option {0020 (Heating/Cooling control output) is selected in [Event output EV2 allocation]} is ordered, or when DS, DA or EV3D□ option is ordered.	
oLlb 0 0000	<b>OUT2 low limit</b> Setting range: 0% to OUT2 high limit value Direct current output type (DA, EV3DA options): -5% to OUT2 high limit value Available when EV2 option {0020 (Heating/Cooling control output) is selected in [Event output EV2 allocation]} is ordered, or when DS, DA or EV3D□ option is ordered.	
db00 0 0000	<b>Overlap/Dead band</b> Setting range: -200.0 to 200.0 °C(°F) DC voltage, current inputs: -2000 to 2000 (The placement of the decimal point follows the selection.) Available when EV2 option {0020 (Heating/Cooling control output) is selected in [Event output EV2 allocation]} is ordered, or when DS, DA or EV3D□ option is ordered.	
co01 0 HEAT	<b>Direct/Reverse action</b>	
	HEAT Reverse (Heating) action COOL Direct (Cooling) action	

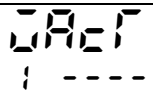
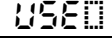
Characters, Factory Default	Setting Item, Setting Range	Data
<p>H 100 0 0000 H 100 and CT1 current value are alternately indicated.</p>	<p><b>Heater burnout alarm 1 value</b> Setting range: 20 A: 0.0 to 20.0 A 100 A: 0.0 to 100.0 A Available when C5W, EIW, W option is ordered, and OUT1 is relay contact output or non-contact voltage output type.</p>	
<p>H200 0 0000 H200 and CT2 current value are alternately indicated.</p>	<p><b>Heater burnout alarm 2 value</b> Setting range: 20 A: 0.0 to 20.0 A 100 A: 0.0 to 100.0 A Available when C5W, EIW, W option is ordered, and OUT1 is relay contact output or non-contact voltage output type.</p>	
<p>LP_T 0 0000</p>	<p><b>Loop break alarm time</b> Setting range: 0 to 200 minutes Available when 00 14 (Loop break alarm output) is selected in [Event output EV□ allocation].</p>	
<p>LP_H 0 0000</p>	<p><b>Loop break alarm span</b> Setting range: Thermocouple, RTD input without decimal point: 0 to 150°C (°F) Thermocouple, RTD input with decimal point: 0.0 to 150.0°C (°F) DC voltage, current inputs: 0 to 1500 (The placement of the decimal point follows the selection.) Available when 00 14 (Loop break alarm output) is selected in [Event output EV□ allocation].</p>	

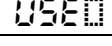
### 13.5 Wait Parameter Setting Mode

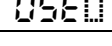
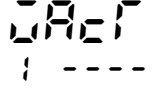
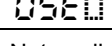
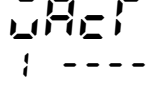
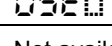
Characters, Factory Default	Setting Item, Setting Range	Data
	<b>Wait value</b> Setting range: 0 to 20% of input span (*) (*) DC voltage, current inputs: 0 to 20% of scaling span (The placement of the decimal point follows the selection.)	
 PTN/STEP indicator 1 lights up.	<b>Step 1 wait function Enabled/Disabled</b>	
	---- Disabled	
	 Enabled	
Not available if Wait value is set to 0 or 0.0.		
 PTN/STEP indicator 2 lights up.	<b>Step 2 wait function Enabled/Disabled</b>	
	---- Disabled	
	 Enabled	
Not available if Wait value is set to 0 or 0.0.		
 PTN/STEP indicator 3 lights up.	<b>Step 3 wait function Enabled/Disabled</b>	
	---- Disabled	
	 Enabled	
Not available if Wait value is set to 0 or 0.0.		
 PTN/STEP indicator 4 lights up.	<b>Step 4 wait function Enabled/Disabled</b>	
	---- Disabled	
	 Enabled	
Not available if Wait value is set to 0 or 0.0.		
 PTN/STEP indicator 5 lights up.	<b>Step 5 wait function Enabled/Disabled</b>	
	---- Disabled	
	 Enabled	
Not available if Wait value is set to 0 or 0.0.		
 PTN/STEP indicator 6 lights up.	<b>Step 6 wait function Enabled/Disabled</b>	
	---- Disabled	
	 Enabled	
Not available if Wait value is set to 0 or 0.0.		
 PTN/STEP indicator 7 lights up.	<b>Step 7 wait function Enabled/Disabled</b>	
	---- Disabled	
	 Enabled	
Not available if Wait value is set to 0 or 0.0.		
 PTN/STEP indicator 8 lights up.	<b>Step 8 wait function Enabled/Disabled</b>	
	---- Disabled	
	 Enabled	
Not available if Wait value is set to 0 or 0.0.		
 PTN/STEP indicator 9 lights up.	<b>Step 9 wait function Enabled/Disabled</b>	
	---- Disabled	
	 Enabled	
Not available if Wait value is set to 0 or 0.0.		

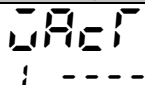
Characters, Factory Default	Setting Item, Setting Range		Data	
 PTN/STEP indicator 10 lights up.	<b>Step 10 wait function Enabled/Disabled</b>			
	----	Disabled		
	USE	Enabled		
	Not available if Wait value is set to 0 or 0.0.			



### 13.6 Engineering Setting Mode 1

Characters, Factory Default	Setting Item, Setting Range			Data
<b>Lock</b> 0 ----	<b>Set value lock</b>			
			<b>Change via Keypad</b>	<b>Change via Software Communication</b>
	----	Unlock	All set values can be changed.	All set values can be changed.
	Loc 1	Lock 1	Only 'Set value lock' can be changed.	
	Loc 2	Lock 2	Setting items selected in [Changeable in Set value lock] can be changed. Only 'Set value lock' can be changed.	Setting items – except Input type – can be changed temporarily via software communication. However, if power is turned ON again, the set values revert to the values before Lock 3, 4 or 5 was selected.
	Loc 3	Lock 3	All set values can be changed.	
	Loc 4	Lock 4	Only 'Set value lock' can be changed. Other setting items cannot be changed.	
Loc 5	Lock 5	Setting items selected in [Changeable in Set value lock] can be changed. Only 'Set value lock' can be changed.		
<b>LoSE</b> 0 5800	<b>Changeable in Set value lock</b>			
	5800	Step SV, Step time can be changed.		
	58E8	Step SV, Step time, EV <input type="checkbox"/> alarm value can be changed.		
<b>So60</b> 0 1000	<b>Sensor correction coefficient</b> Setting range: -10.000 to 10.000			
<b>So00</b> 0 0000	<b>Sensor correction</b> Setting range: -1000.0 to 1000.0°C (°F) DC voltage, current inputs: -10000 to 10000 (The placement of the decimal point follows the selection.)			
<b>FlLT</b> 0 0000	<b>PV filter time constant</b> Setting range: 0.0 to 10.0 seconds			
<b>cASL</b> 0 noAL	<b>Communication protocol</b>			
	noAL	Shinko protocol		
	58F0	Set value digital transmission (Shinko protocol)		
	58Fr	Set value digital reception (Shinko protocol)		
	nodA	Modbus ASCII mode		
	nodr	Modbus RTU mode		
Available when C5W or C5 option is ordered.				

Characters, Factory Default	Setting Item, Setting Range	Data
<b>cāno</b> 0 0000	<b>Instrument number</b> Setting range: 0 to 95 Available when C5W or C5 option is ordered.	
<b>cāSP</b> 0 0096	<b>Communication speed</b>	
	0096   9600 bps	
	0192   19200 bps	
	0384   38400 bps	
	Available when C5W or C5 option is ordered.	
<b>cāFI</b> 0 7E8n	<b>Data bit/Parity</b>	
	8nan   8 bits/No parity	
	7nan   7 bits/No parity	
	8E8n   8 bits/Even	
	7E8n   7 bits/Even	
	8odd   8 bits/Odd	
	7odd   7 bits/Odd	
	Available when C5W or C5 option is ordered.	
<b>cāSI</b> 0 0001	<b>Stop bit</b>	
	0001   1 bit	
	0002   2 bits	
	Available when C5W or C5 option is ordered.	
<b>cād4</b> 0 0010	<b>Response delay time</b> Setting range: 0 to 1000 ms Available when C5W or C5 option is ordered.	
<b>SB_b</b> 0 0000	<b>SVTC bias</b> Setting range: ±20% of input span DC voltage, current inputs: ±20% of scaling span (The placement of the decimal point follows the selection.) Available when C5W, C5 option is ordered, or when <b>SB r</b> [Set value digital reception (Shinko protocol)] is selected in [Communication protocol].	

### 13.7 Engineering Setting Mode 2

Characters, Factory Default	Setting Item, Setting Range		Data
SEnS 0 1370	<b>Input type</b>		
	1300C	K -200 to 1370 °C	
	130.0C	K -200.0 to 400.0 °C	
	1300C	J -200 to 1000 °C	
	1300C	R 0 to 1760 °C	
	1300C	S 0 to 1760 °C	
	1300C	B 0 to 1820 °C	
	1300C	E -200 to 800 °C	
	130.0C	T -200.0 to 400.0 °C	
	1300C	N -200 to 1300 °C	
	1320C	PL-II 0 to 1390 °C	
	1300C	C(W/Re5-26) 0 to 2315 °C	
	130.0C	Pt100 -200.0 to 850.0 °C	
	1300C	JPt100 -200.0 to 500.0 °C	
	1300C	Pt100 -200 to 850 °C	
	1300C	JPt100 -200 to 500 °C	
	1300F	K -328 to 2498 °F	
	130.0F	K -328.0 to 752.0 °F	
	1300F	J -328 to 1832 °F	
	1300F	R 32 to 3200 °F	
	1300F	S 32 to 3200 °F	
	1300F	B 32 to 3308 °F	
	1300F	E -328 to 1472 °F	
	130.0F	T -328.0 to 752.0 °F	
	1300F	N -328 to 2372 °F	
	1320F	PL-II 32 to 2534 °F	
	1300F	C(W/Re5-26) 32 to 4199 °F	
	130.0F	Pt100 -328.0 to 1562.0 °F	
	1300F	JPt100 -328.0 to 932.0 °F	
	1300F	Pt100 -328 to 1562 °F	
	1300F	JPt100 -328 to 932 °F	
	420A	4 to 20 mA -2000 to 10000	
020A	0 to 20 mA -2000 to 10000		
001V	0 to 1 V -2000 to 10000		
005V	0 to 5 V -2000 to 10000		
105V	1 to 5 V -2000 to 10000		
010V	0 to 10 V -2000 to 10000		
SEnS 0 1370	<b>Scaling high limit</b> Setting range: Scaling low limit to Input range high limit DC voltage, current inputs: -2000 to 10000 (The placement of the decimal point follows the selection.)		

Characters, Factory Default	Setting Item, Setting Range	Data																																								
SLL 0 -200	<b>Scaling low limit</b> Setting range: Input range low limit to Scaling high limit DC voltage, current inputs: -2000 to 10000 (The placement of the decimal point follows the selection.)																																									
dP00 0 0000	<b>Decimal point place</b> <table border="1"> <tr> <td>0000</td> <td>No decimal point</td> </tr> <tr> <td>0000</td> <td>1 digit after decimal point</td> </tr> <tr> <td>0000</td> <td>2 digits after decimal point</td> </tr> <tr> <td>0000</td> <td>3 digits after decimal point</td> </tr> </table> Available when DC voltage or current input is selected in [Input type].	0000	No decimal point	0000	1 digit after decimal point	0000	2 digits after decimal point	0000	3 digits after decimal point																																	
0000	No decimal point																																									
0000	1 digit after decimal point																																									
0000	2 digits after decimal point																																									
0000	3 digits after decimal point																																									
EV01 0 0000	<b>Event output EV1 allocation</b> <table border="1"> <tr> <td>0000</td> <td>No event</td> </tr> <tr> <td>0001</td> <td>Alarm output, High limit alarm</td> </tr> <tr> <td>0002</td> <td>Alarm output, Low limit alarm</td> </tr> <tr> <td>0003</td> <td>Alarm output, High/Low limits alarm</td> </tr> <tr> <td>0004</td> <td>Alarm output, High/Low limits independent alarm</td> </tr> <tr> <td>0005</td> <td>Alarm output, High/Low limit range alarm</td> </tr> <tr> <td>0006</td> <td>Alarm output, High/Low limit range independent alarm</td> </tr> <tr> <td>0007</td> <td>Alarm output, Process high alarm</td> </tr> <tr> <td>0008</td> <td>Alarm output, Process low alarm</td> </tr> <tr> <td>0009</td> <td>Alarm output, High limit with standby alarm</td> </tr> <tr> <td>0010</td> <td>Alarm output, Low limit with standby alarm</td> </tr> <tr> <td>0011</td> <td>Alarm output, High/Low limits with standby alarm</td> </tr> <tr> <td>0012</td> <td>Alarm output, High/Low limits with standby independent alarm</td> </tr> <tr> <td>0013</td> <td>Heater burnout alarm output (When C5W, EIW or W option is ordered)</td> </tr> <tr> <td>0014</td> <td>Loop break alarm output</td> </tr> <tr> <td>0015</td> <td>Time signal output</td> </tr> <tr> <td>0016</td> <td>Output during AT</td> </tr> <tr> <td>0017</td> <td>Pattern end output</td> </tr> <tr> <td>0018</td> <td>Output by communication command</td> </tr> <tr> <td>0019</td> <td>RUN output</td> </tr> </table> <p>When 0001 (High limit alarm) to 0012 (High/Low limit with standby independent alarm) or 0015 (Time signal output) is selected, one output can be set to one event output.</p> <p>When 0013 (Heater burnout alarm output), 0014 (Loop break alarm), 0016 (Output during AT) to 0019 (RUN output) are selected, each output is common to multiple event outputs.</p>	0000	No event	0001	Alarm output, High limit alarm	0002	Alarm output, Low limit alarm	0003	Alarm output, High/Low limits alarm	0004	Alarm output, High/Low limits independent alarm	0005	Alarm output, High/Low limit range alarm	0006	Alarm output, High/Low limit range independent alarm	0007	Alarm output, Process high alarm	0008	Alarm output, Process low alarm	0009	Alarm output, High limit with standby alarm	0010	Alarm output, Low limit with standby alarm	0011	Alarm output, High/Low limits with standby alarm	0012	Alarm output, High/Low limits with standby independent alarm	0013	Heater burnout alarm output (When C5W, EIW or W option is ordered)	0014	Loop break alarm output	0015	Time signal output	0016	Output during AT	0017	Pattern end output	0018	Output by communication command	0019	RUN output	
0000	No event																																									
0001	Alarm output, High limit alarm																																									
0002	Alarm output, Low limit alarm																																									
0003	Alarm output, High/Low limits alarm																																									
0004	Alarm output, High/Low limits independent alarm																																									
0005	Alarm output, High/Low limit range alarm																																									
0006	Alarm output, High/Low limit range independent alarm																																									
0007	Alarm output, Process high alarm																																									
0008	Alarm output, Process low alarm																																									
0009	Alarm output, High limit with standby alarm																																									
0010	Alarm output, Low limit with standby alarm																																									
0011	Alarm output, High/Low limits with standby alarm																																									
0012	Alarm output, High/Low limits with standby independent alarm																																									
0013	Heater burnout alarm output (When C5W, EIW or W option is ordered)																																									
0014	Loop break alarm output																																									
0015	Time signal output																																									
0016	Output during AT																																									
0017	Pattern end output																																									
0018	Output by communication command																																									
0019	RUN output																																									
A1EA 0 no00	<b>EV1 alarm value 0 Enabled/Disabled</b> <table border="1"> <tr> <td>no00</td> <td>Disabled</td> </tr> <tr> <td>YES0</td> <td>Enabled</td> </tr> </table> Available when any alarm from 0001 (High limit alarm) to 0012 (High/Low limits with standby independent alarm) is selected in [Event output EV1 allocation] - excluding 0007 (Process high alarm) and 0008 (Process low alarm).	no00	Disabled	YES0	Enabled																																					
no00	Disabled																																									
YES0	Enabled																																									

Characters, Factory Default	Setting Item, Setting Range	Data																																										
A 1H4 0 00 0	<b>EV1 alarm hysteresis</b> Setting range: 0.1 to 1000.0°C (°F), DC voltage, current inputs: 1 to 10000 (The placement of the decimal point follows the selection.) Available when any alarm from 000 1 (High limit alarm) to 00 12 (High/Low limits with standby independent alarm) is selected in [Event output EV1 allocation].																																											
A 1d4 0 0000	<b>EV1 alarm delay time</b> Setting range: 0 to 10000 seconds Available when any alarm from 000 1 (High limit alarm) to 00 12 (High/Low limits with standby independent alarm) is selected in [Event output EV1 allocation].																																											
A 1L A 0 000L	<b>EV1 alarm Energized/De-energized</b> <table border="1"> <tr> <td>000L</td> <td>Energized</td> </tr> <tr> <td>000S</td> <td>De-energized</td> </tr> </table> Available when any alarm from 000 1 (High limit alarm) to 00 12 (High/Low limits with standby independent alarm) is selected in [Event output EV1 allocation].	000L	Energized	000S	De-energized																																							
000L	Energized																																											
000S	De-energized																																											
E 002 0 0000	<b>Event output EV2 allocation</b> <table border="1"> <tr> <td>0000</td> <td>No event</td> </tr> <tr> <td>0001</td> <td>Alarm output, High limit alarm</td> </tr> <tr> <td>0002</td> <td>Alarm output, Low limit alarm</td> </tr> <tr> <td>0003</td> <td>Alarm output, High/Low limits alarm</td> </tr> <tr> <td>0004</td> <td>Alarm output, High/Low limits independent alarm</td> </tr> <tr> <td>0005</td> <td>Alarm output, High/Low limit range alarm</td> </tr> <tr> <td>0006</td> <td>Alarm output, High/Low limit range independent alarm</td> </tr> <tr> <td>0007</td> <td>Alarm output, Process high alarm</td> </tr> <tr> <td>0008</td> <td>Alarm output, Process low alarm</td> </tr> <tr> <td>0009</td> <td>Alarm output, High limit with standby alarm</td> </tr> <tr> <td>00 10</td> <td>Alarm output, Low limit with standby alarm</td> </tr> <tr> <td>00 11</td> <td>Alarm output, High/Low limits with standby alarm</td> </tr> <tr> <td>00 12</td> <td>Alarm output, High/Low limits with standby independent alarm</td> </tr> <tr> <td>00 13</td> <td>Heater burnout alarm output (When C5W, EIW or W option is ordered)</td> </tr> <tr> <td>00 14</td> <td>Loop break alarm output</td> </tr> <tr> <td>00 15</td> <td>Time signal output</td> </tr> <tr> <td>00 16</td> <td>Output during AT</td> </tr> <tr> <td>00 17</td> <td>Pattern end output</td> </tr> <tr> <td>00 18</td> <td>Output by communication command</td> </tr> <tr> <td>00 19</td> <td>RUN output</td> </tr> <tr> <td>0020</td> <td>Heating/Cooling control Relay contact output</td> </tr> </table> When 000 1 (High limit alarm) to 00 12 (High/Low limit with standby independent alarm) or 00 15 (Time signal output) is selected, one output can be set to one event output. When 00 13 (Heater burnout alarm output), 00 14 (Loop break alarm), 00 16 (Output during AT) to 00 19 (RUN output) are selected, each output is common to multiple event outputs. Available when the EV2 or EV3(DR) option is ordered.	0000	No event	0001	Alarm output, High limit alarm	0002	Alarm output, Low limit alarm	0003	Alarm output, High/Low limits alarm	0004	Alarm output, High/Low limits independent alarm	0005	Alarm output, High/Low limit range alarm	0006	Alarm output, High/Low limit range independent alarm	0007	Alarm output, Process high alarm	0008	Alarm output, Process low alarm	0009	Alarm output, High limit with standby alarm	00 10	Alarm output, Low limit with standby alarm	00 11	Alarm output, High/Low limits with standby alarm	00 12	Alarm output, High/Low limits with standby independent alarm	00 13	Heater burnout alarm output (When C5W, EIW or W option is ordered)	00 14	Loop break alarm output	00 15	Time signal output	00 16	Output during AT	00 17	Pattern end output	00 18	Output by communication command	00 19	RUN output	0020	Heating/Cooling control Relay contact output	
0000	No event																																											
0001	Alarm output, High limit alarm																																											
0002	Alarm output, Low limit alarm																																											
0003	Alarm output, High/Low limits alarm																																											
0004	Alarm output, High/Low limits independent alarm																																											
0005	Alarm output, High/Low limit range alarm																																											
0006	Alarm output, High/Low limit range independent alarm																																											
0007	Alarm output, Process high alarm																																											
0008	Alarm output, Process low alarm																																											
0009	Alarm output, High limit with standby alarm																																											
00 10	Alarm output, Low limit with standby alarm																																											
00 11	Alarm output, High/Low limits with standby alarm																																											
00 12	Alarm output, High/Low limits with standby independent alarm																																											
00 13	Heater burnout alarm output (When C5W, EIW or W option is ordered)																																											
00 14	Loop break alarm output																																											
00 15	Time signal output																																											
00 16	Output during AT																																											
00 17	Pattern end output																																											
00 18	Output by communication command																																											
00 19	RUN output																																											
0020	Heating/Cooling control Relay contact output																																											



Characters, Factory Default	Setting Item, Setting Range	Data
A23A 0 no00	<b>EV2 alarm value 0 Enabled/Disabled</b>	
	no00   Disabled	
	YES0   Enabled	
Available when any alarm from 0001 (High limit alarm) to 0012 (High/Low limits with standby independent alarm) is selected in [Event output EV2 allocation] - excluding 0007 (Process high alarm) and 0008 (Process low alarm).		
A24Y 0 0010	<b>EV2 alarm hysteresis</b> Setting range: 0.1 to 1000.0°C (°F), DC voltage, current inputs: 1 to 10000 (The placement of the decimal point follows the selection.) Available when any alarm from 0001 (High limit alarm) to 0012 (High/Low limits with standby independent alarm) is selected in [Event output EV2 allocation].	
A24Y 0 0000	<b>EV2 alarm delay time</b> Setting range: 0 to 10000 seconds Available when any alarm from 0001 (High limit alarm) to 0012 (High/Low limits with standby independent alarm) is selected in [Event output EV2 allocation].	
A2LA 0 no0L	<b>EV2 alarm Energized/De-energized</b>	
	no0L   Energized	
	re05   De-energized	
Available when any alarm from 0001 (High limit alarm) to 0012 (High/Low limits with standby independent alarm) is selected in [Event output EV2 allocation].		
E603 0 0000	<b>Event output EV3 allocation</b>	
	0000   No event	
	0001   Alarm output, High limit alarm	
	0002   Alarm output, Low limit alarm	
	0003   Alarm output, High/Low limits alarm	
	0004   Alarm output, High/Low limits independent alarm	
	0005   Alarm output, High/Low limit range alarm	
	0006   Alarm output, High/Low limit range independent alarm	
	0007   Alarm output, Process high alarm	
	0008   Alarm output, Process low alarm	
	0009   Alarm output, High limit with standby alarm	
	0010   Alarm output, Low limit with standby alarm	
	0011   Alarm output, High/Low limits with standby alarm	
	0012   Alarm output, High/Low limits with standby independent alarm	
	0013   Heater burnout alarm output (When C5W, EIW or W option is ordered)	
	0014   Loop break alarm output	
	0015   Time signal output	
	0016   Output during AT	
	0017   Pattern end output	
	0018   Output by communication command	
0019   RUN output		
When 0001 (High limit alarm) to 0012 (High/Low limit with standby independent alarm) or 0015 (Time signal output) is selected, one output can be set to one event output. When 0013 (Heater burnout alarm output), 0014 (Loop break alarm), 0016 (Output during AT) to 0019 (RUN output) are selected, each output is common to multiple event outputs. Available when the EV3D□ or EI option is ordered.		

Characters, Factory Default	Setting Item, Setting Range			Data
<b>A3EA</b> 0 0000	<b>EV3 alarm value 0 Enabled/Disabled</b>			
	no00	Disabled		
	YES0	Enabled		
	Available when any alarm from 000 1 (High limit alarm) to 00 12 (High/Low limits with standby independent alarm) is selected in [Event output EV3 allocation] - excluding 0007 (Process high alarm) and 0008 (Process low alarm).			
<b>A3HY</b> 0 00 0	<b>EV3 alarm hysteresis</b>			
	Setting range: 0.1 to 1000.0°C (°F), DC voltage, current inputs: 1 to 10000 (The placement of the decimal point follows the selection.) Available when any alarm from 000 1 (High limit alarm) to 00 12 (High/Low limits with standby independent alarm) is selected in [Event output EV3 allocation].			
<b>A3dY</b> 0 0000	<b>EV3 alarm delay time</b>			
	Setting range: 0 to 10000 seconds Available when any alarm from 000 1 (High limit alarm) to 00 12 (High/Low limits with standby independent alarm) is selected in [Event output EV3 allocation].			
<b>A3LA</b> 0 000L	<b>EV3 alarm Energized/De-energized</b>			
	no0L	Energized		
	rEB5	De-energized		
	Available when any alarm from 000 1 (High limit alarm) to 00 12 (High/Low limits with standby independent alarm) is selected in [Event output EV3 allocation].			
<b>E6I 1</b> 0 0000	<b>Event input DI1 allocation</b>			
		<b>Event input function</b>	<b>Input ON (Closed)</b>	<b>Input OFF (Open)</b>
	0000	No event		
	000 1	Pattern number selection		
	0002	Direct/Reverse action	Direct action	Reverse action
	0003	Program control RUN/STOP	RUN	STOP
	0004	Program control Holding/Not holding	Holding	Not holding
	0005	Program control Advance function	Advance function	Usual control
Available when C5W, EIW, EIT, C5 or EI option is ordered.				



Characters, Factory Default	Setting Item, Setting Range			Data	
<b>EI 2</b> 0 0000	<b>Event input DI2 allocation</b>				
		<b>Event input function</b>	<b>Input ON (Closed)</b>		<b>Input OFF (Open)</b>
	0000	No event			
	0001	Pattern number selection			
	0002	Direct/Reverse action	Direct action		Reverse action
	0003	Program control RUN/STOP	RUN		STOP
	0004	Program control Holding/Not holding	Holding		Not holding
	0005	Program control Advance function	Advance function		Usual control
Available when C5W, EIW, EIT, C5 or EI option is ordered.					
<b>Tr05</b> 0 P800	<b>Transmission output type</b>				
	P800	PV transmission			
	S800	SV transmission			
	M800	MV transmission			
Available when EIT option is ordered.					
<b>TrLH</b> 0 1370	<b>Transmission output high limit</b>				
Setting range: PV, SV transmission: Transmission output low limit to Input range high limit Direct current, voltage inputs: -2000 to 10000 (The placement of the decimal point follows the selection.) MV transmission: Transmission output low limit to 105.0% Available when EIT option is ordered.					
<b>TrLL</b> 0 -200	<b>Transmission output low limit</b>				
Setting range: PV, SV transmission: Input range low limit to Transmission output high limit Direct current, voltage inputs: -2000 to 10000 (The placement of the decimal point follows the selection.) MV transmission: -5.0% to Transmission output high limit Available when EIT option is ordered.					
<b>M_50</b> 0 M 00	<b>Step time unit</b>				
	M 00	Hours : Minutes			
	SECD	Minutes : Seconds			

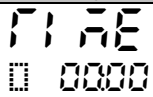

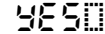
Characters, Factory Default	Setting Item, Setting Range	Data
<b>P_rEt</b> 0 stop	<b>Power restore action</b>	
	<b>stop</b>	Stops after power is restored. After power is restored, stops current program control, and returns to the Program control STOP (in Standby).
	<b>conf</b>	Continues (resumes) after power is restored. Continues (resumes) previous program control after power is restored.
	<b>Hold</b>	Suspends after power is restored. After power is restored, suspends (on hold) current program control, and performs Fixed value control using the SV from the point of suspension. Pressing the <b>[RUN]</b> key cancels suspension, and Program control resumes.
<b>S_5H</b> 0 0000	<b>Step SV when program control starts</b> Setting range: Scaling low limit to Scaling high limit (The placement of the decimal point follows the selection.)	
<b>S_5L</b> 0 P800	<b>Program control start type</b>	
	<b>P800</b>	<b>PV start:</b> Only when Program control starts, the step SV and step time are advanced to the PV, then Program control starts.
	<b>P8r0</b>	<b>PVR start:</b> When Program control starts and in pattern repeating, the step SV and step time are advanced to the PV, then Program control starts.
<b>5800</b>	<b>SV start:</b> When Program control starts, the Program control starts from the step SV set in [Step SV when program control starts].	
<b>PEtA</b> 0 0000	<b>Pattern end output time</b> Setting range: 0 to 10000 seconds	
<b>AT_b</b> 0 0020	<b>AT bias</b> Setting range: Thermocouple, RTD inputs without decimal point: 0 to 50°C (0 to 100°F) Thermocouple, RTD inputs with decimal point: 0.0 to 50.0°C (0.0 to 100.0°F) Available when Thermocouple or RTD input is selected in [Input type].	
<b>EoUt</b> 0 OFF0	<b>Output status when input errors occur</b>	
	<b>OFF0</b>	Output OFF
	<b>ON00</b>	Output ON
	Available for direct current and voltage inputs, and direct current output.	

Characters, Factory Default	Setting Item, Setting Range	Data
	<b>Indication time</b> Setting range: 00:00 to 60:00 (Minutes : Seconds) When set to 00:00, Displays remain ON.	
	<b>Error indication</b>	
	 Disabled	
	 Enabled	

### 13.8 Data Clear

Characters, Factory Default	Setting Item, Setting Range	Data
	<b>Data clear Yes/No</b>	
	 Data clear No	
	 Data clear Yes	

# 14. Making Program Pattern Table and Data Table

Before setting program, make a program pattern table and data table.

## 14.1 Making Program Pattern Table

Please make a copy of the program pattern table (p.157), and follow the procedure below.

(1) Write a step SV, step time, PID block number, Wait function Enabled/Disabled for each step from Step 1 in numerical order.

(Even if the same block number is used, write for every step.)

(2) Draw a line graph of step SV.

### Program Pattern Table

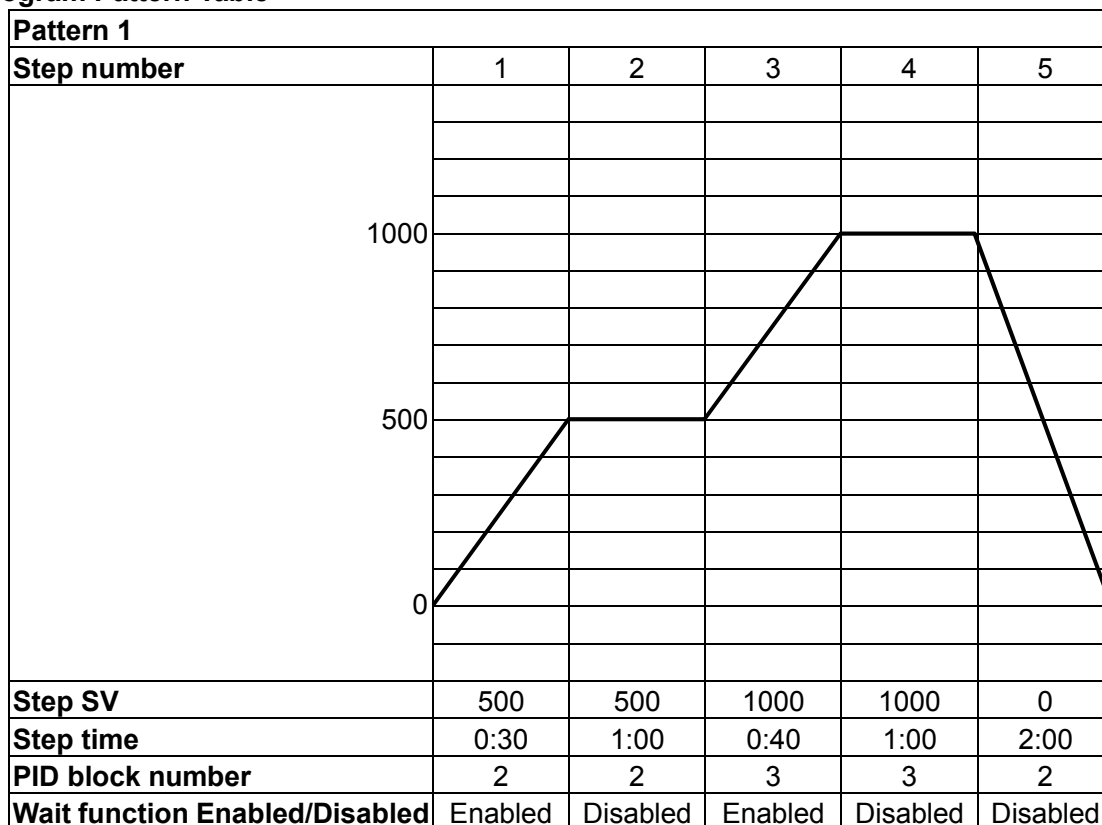

(Fig. 14.1-1)

### Explanation of Program Pattern Table

Program pattern table consists of Y axis which represents the step SV (°C, °F), and X axis which represents the step time (Hours : Minutes, Minutes : Seconds).

Step SV is considered to be the SV at the end of the step.

Step time is considered to be the step process time.

- The relation between the step SV and step time can be explained as follows.
  - Step 1: The control is performed so that the temperature reaches from 0 to 500°C for 30 minutes. Depending on the selection in [Program control start type], control is performed as follows.
    - When SV start is selected: Performs control from the step SV set in [Step SV when program control starts] so that the temperature reaches 500°C.
    - When PV start or PVR start is selected: Step SV and time are advanced to PV, and control starts so that the temperature reaches 500°C.
  - Step 2: The control is performed so that SV is maintained at 500°C for 1 hour.
  - Step 3: The control is performed so that SV rises from 500°C to 1000°C for 40 minutes.
  - Step 4: The control is performed so that SV is maintained at 1000°C for 1 hour.
  - Step 5: The control is performed so that SV drops from 1000°C to 0°C for 2 hours.

- PID block includes: OUT1 proportional band, Integral time, Derivative time, ARW, OUT2 proportional band  
10 types of PID block (1 – 10) can be set.
- Wait function Enabled or Disabled can be selected for each step.

## 14.2 Making Data Table

Please make a copy of Data Table (p.158), and follow the procedure below.

- (1) Write data for block numbers in Control parameter setting mode, by referring to the PID block numbers in the Program pattern table.
- (2) For Wait value and other setting items, write the data in the table if required.

### About PID block settings

If program pattern is not set for a step, its PID block number becomes 1 (factory default). We highly recommend that you leave the factory default values of PID block 1 as they are, and set the values from PID block 2.

#### • Example of PID block setting

PID Block number	OUT1 P-band	Integral time	Derivative time	ARW	OUT2 P-band
1	10°C	200 sec	50 sec	50%	10°C
2	30°C	240 sec	60 sec	35%	10°C
3	50°C	340 sec	85 sec	40%	10°C

#### • Example of Wait value setting

Wait value	10°C
------------	------

Wait value is common to all steps for each pattern.

#### • Example of other setting items

Setting items	Data
OUT1 proportional cycle	15 sec
OUT2 proportional cycle	15 sec
Number of repetitions	1
Pattern link	Pattern link Disabled
Communication protocol	Shinko protocol
Instrument number	1
Communication speed	38400 bps
Data bit/Parity	7 bits/Even
Stop bit	1 bit
Response delay time	10 ms

**Program Pattern Table**

Please make a copy of this table for use.

<b>Pattern number</b>										
<b>Step number</b>	1	2	3	4	5	6	7	8	9	10
<b>Step SV</b>										
<b>Step time</b>										
<b>PID block number</b>										
<b>Wait function Enabled/Disabled</b>										

### Data Table

Please make a copy of this table for use.

#### • PID block

PID Block number	OUT1 P-band	Integral time	Derivative time	ARW	OUT2 P-band
1		sec	sec	%	
2		sec	sec	%	
3		sec	sec	%	
4		sec	sec	%	
5		sec	sec	%	
6		sec	sec	%	
7		sec	sec	%	
8		sec	sec	%	
9		sec	sec	%	
10		sec	sec	%	

#### • Wait value

Wait value	
------------	--

Wait value is common to all steps for each pattern.

#### • Other setting data (Please use the blank for your own usage. )

Setting item	Data
OUT1 proportional cycle	sec
OUT2 proportional cycle	sec
Number of repetitions	times
Pattern link	
Communication protocol	
Instrument number	
Communication speed	bps
Data bit/Parity	
Stop bit	
Response delay time	ms

# 15. Key Operation Flowchart

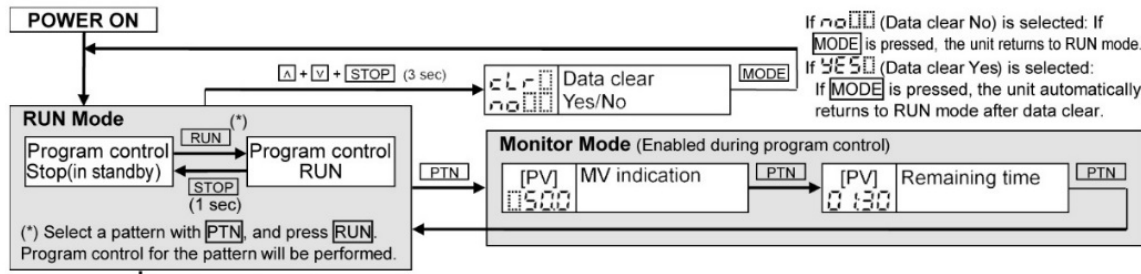

## About Setting Item

- **Step 1 SV**: Upper left: PV Display: Indicates setting characters. Lower left: SV Display: Indicates factory default. Right side: Indicates setting items.
- **EV2 alarm value**: Shaded setting items are optional, and appear only when the options are ordered.
- (\*1) Available when 001 (High limit) to 012 (H/L limits with standby independent) are selected in [Event output EV] allocation.
- (\*2) Available when 004 (H/L limits independent), 006 (H/L limit range independent) or 012 (H/L limits with standby independent) is selected in [Event output EV] allocation.
- (\*3) Available when 015 (Time signal output) is selected in [Event output EV] allocation.
- (\*4) Available when SV digital reception (Shinko protocol) is selected in [Communication protocol].
- (\*5) Available when direct current or DC voltage input is selected in [Input type].
- (\*6) Available when 001(High limit) to 012 (H/L limits with standby independent) – except [007 (Process high) and 008 (Process low)] – are selected in [Event output EV] allocation.

## Key Operation

- Use **▲** and **▼** for settings, and register the settings with **MODE** or **DISP**.
- **MODE**: Moves to the next item, illustrated by an arrow.
- **DISP**: Moves back to the previous item (Opposite to **MODE**).
- **MODE** (3 sec): Press **MODE** for approx. 3 seconds.
- **▲+MODE**: Press **▲** and **MODE** (in that order) together.
- **▲+▼** (3 sec): Press **▲** and **▼** (in that order) together for 3 seconds.
- **▼+MODE** (3 sec): Press **▼** and **MODE** (in that order) together for 3 seconds.
- **▲+▼+MODE** (3 sec): Press **▲**, **▼** and **MODE** (in that order) together for 3 seconds.
- **▲+▼+STOP** (3 sec): Press **▲**, **▼** and **STOP** (in that order) together for 3 seconds.
- **RST**: Returns to RUN mode from any setting items.

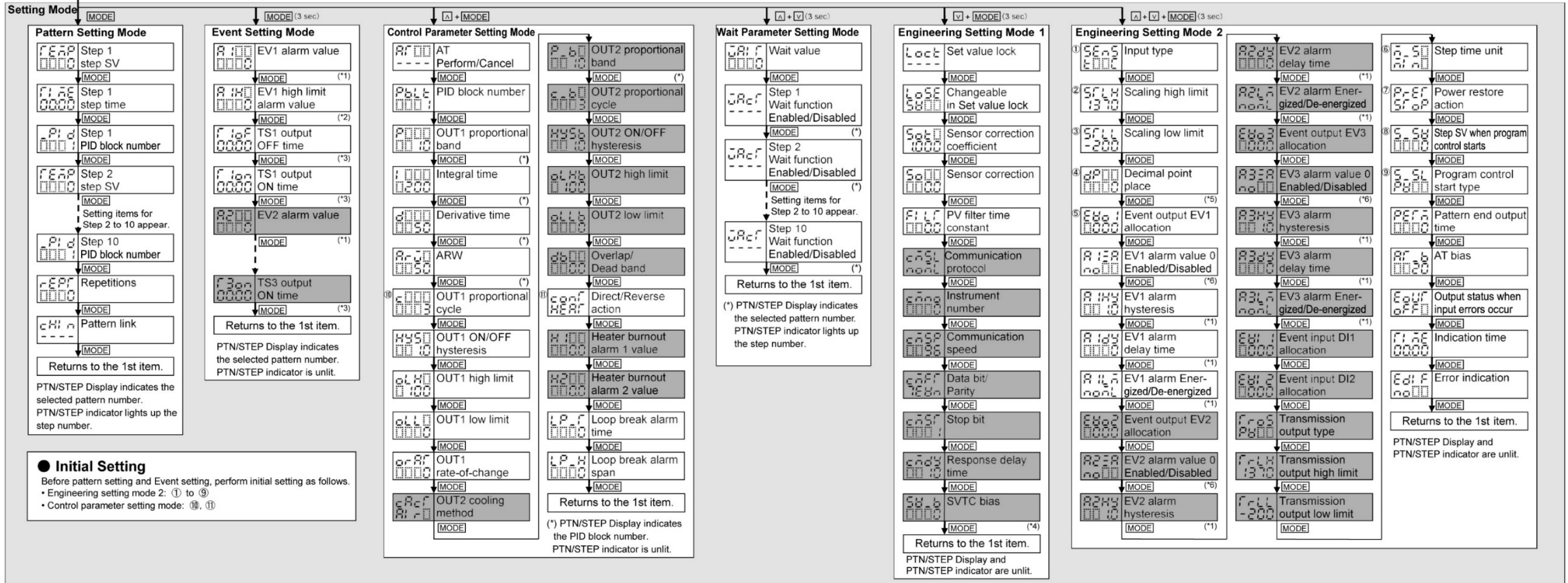

Pattern link	Lock 5	Stop bit	Input type	Temperature	Event output EV1 to EV3 allocation	Power restore action
----	Changeable in Set value lock	1 bit	K	32 to 3200 °F	Event output EV1 to EV3 allocation	Stops after power is restored
CH: n	Step SV + Step time	2 bits	J	32 to 3308 °F	No event	Continues after power is restored
AT Perform / Cancel	Step SV + Step time + EV alarm value		K	-328 to 1472 °F	High limit alarm	Suspends after power is restored
----	Step SV + Step time + EV alarm value		T	-328.0 to 752.0 °F	Low limit alarm	Program control start type
AT Perform	Communication protocol		N	-328 to 2372 °F	H/L limits alarm	EV1 to EV3 alarm Energized / De-energized
OUT2 cooling method	Shinko protocol		PL-II	32 to 2534 °F	H/L limits independent alarm	Energized
Air cooling	SV digital transmission (Shinko protocol)		C(W/Re5-26)	32 to 4199 °F	H/L limit range alarm	De-energized
Oil cooling	SV digital reception (Shinko protocol)		Pt100	-328.0 to 1562.0 °F	H/L limit range independent alarm	Event input DI1, DI2 allocation
Water cooling	Modbus ASCII mode		JPt100	-328.0 to 932.0 °F	Process high alarm	Output status when input errors occur
Direct / Reverse action	Modbus RTU mode		Pt100	-328 to 1562 °F	Process low alarm	Output OFF
Reverse control action	Communication speed		JPt100	-328 to 932 °F	High limit with standby alarm	Output ON
Direct control action	9600 bps		N	-200 to 1300 °C	Low limit with standby alarm	Error indication
Step 1 to 10 Wait function Enabled / Disabled	19200 bps		PL-II	0 to 1390 °C	H/L limits with standby alarm	Program control RUN / STOP
Disabled	38400 bps		C(W/Re5-26)	0 to 2315 °C	H/L limits with standby independent	Program control Holding / Not holding
Enabled	Data bit / Parity		Pt100	-200.0 to 850.0 °C	H/L limits with standby independent	Program control Advance function
Set value lock	8 bits / No parity		JPt100	-200.0 to 500.0 °C	Heater burnout alarm output	Transmission output type
----	7 bits / No parity		Pt100	-200 to 850 °C	1 - 5 V	PV transmission
Lock 1	8 bits / Even		JPt100	-200 to 500 °C	0 - 5 V	SV transmission
Lock 2	7 bits / Even		K	-328 to 2498 °F	1 - 5 V	MV transmission
Lock 3	8 bits / Odd		F	-328.0 to 752.0 °F	0 - 10 V	Step time unit
Lock 4	7 bits / Odd		J	-328 to 1832 °F	No decimal point	Hours : Minutes
					1 digit after decimal point	Minutes : Seconds
					2 digits after decimal point	

\*\*\*\*\* Inquiries \*\*\*\*\*

For any inquiries about this unit, please contact our agency or the vendor where you purchased the unit after checking the following.

[Example]

- Model ----- PCB1R00-52
- Option ----- EV3(DR), C5W(100A)
- Serial number ----- No. 173F05000

In addition to the above, please let us know the details of the malfunction, or discrepancy, and the operating conditions.

**SHINKO TECHNOS CO., LTD.**  
**OVERSEAS DIVISION**

Head Office : 2-5-1, Senbahigashi, Minoo, Osaka, Japan

URL: <http://www.shinko-technos.co.jp/e/>

E-mail: [overseas@shinko-technos.co.jp](mailto:overseas@shinko-technos.co.jp)

Tel : +81-72-727-6100

Fax: +81-72-727-7006