



- » Analog switching AC solid state relay.
- » Two input ranges: 4 - 20 mA and 2 - 10 VDC.
- » Maximum load current (AC1 at 25° C): 25, 40, 60, 80, 100 A.
- » Operational ratings: 0 - 380 VAC.
- » Frequency range: 50 - 60 Hz.
- » Maximum non-repetitive peak voltage: 850 Vp.
- » Clip on protective cover for greater safety (IP 20).

References

Control voltage	Operational voltage	Operational current	Reference	Ref. heat sink
2 - 10VDC	240 VAC	25 A	RS1APV010DC240025R	RSH-060
		40 A	RS1APV010DC240040R	RSH-061
		60 A	RS1APV010DC380060R	RSH-038
	380 VAC	80 A	RS1APV010DC380080R	RSH-038
		100 A	RS1APV010DC380100R	RSH-039
4 - 20mA	240 VAC	25 A	RS1API420mA240025R	RSH-060
		40 A	RS1API420mA240040R	RSH-061
	380 VAC	60 A	RS1API420mA380060R	RSH-038
		80 A	RS1API420mA380080R	RSH-038
		100 A	RS1API420mA380100R	RSH-039

General specifications

Dielectric insulation (between input & output)	2.500 VAC
Operating temperature	-40 °C to 80 °C
Storage temperature	-45 °C to 85 °C
Rth junction to case	2,5° C/W(25A)
	0,5° C/W(80A)
	1,25° C/W(40A)
	0,3° C/W(100A)
Ambient humidity	Operating: up to 85 %
CE marking	Yes

Input specifications

	VDC input	Current
Control voltage range	2 - 10 VDC	4 - 20 mA
And control mA range	13/16 mA @= 5 V/24 V	29 mA @= 220 VAC
Pick-up voltage	1,9 VDC	70 VAC
Drop-out voltage	1,9 VDC	70 VAC
Maximum reverse voltage	32 VDC	-
Max. response time pick-up	1 ms	-
Max. response time drop-out	½ cycle	-

Output specifications

Maximum load current	(AC51 @ Ta = 25° C)	25, 40, 60, 80, 100 A
	(AC53a @ Ta = 25° C)	5, 15, 18, 20 A
Load voltage range	0 - 240VAC / 0 - 380 VAC	
Frequency range	50 - 60 Hz	
Max. non-repetitive peak voltage	850 Vp	
Max. non-repetitive peak current (t=10ms)	350 Ap / 25 A	910 Ap / 80 A
	500 Ap / 40 A	1100 Ap / 100 A
	630 Ap / 60 A	
Maximum off state leakage current	8 mArms	
Minimum off state dv / dt	200 V / µseg	
Maximum on state voltage	1,6 VAC	
Minimum load current	0,15 - 0,25Arms	
I ² t (10 ms) (orientative data)	625 A ² s (25 A)	4.225 A ² s (80 A)
	1.250 A ² s (40A)	6.050 A ² s (100A)
	2.025 A ² s (60A)	

Housing specifications

Dimensions (L x W x H mm)	57 x 44 x 23
Weight	160 gr max.
Baseplate	Aluminum, nickel-plated
Control terminal (M3x6) torque	1,2 Nm
Power terminal (M5x9) torque	2,4 Nm

Load current vs. ambient temperature

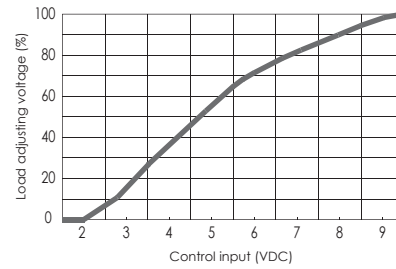

RS1APV010DC240025R
RS1APV010DC240040R
RS1APV010DC380060R
RS1APV010DC380080R
RS1APV010DC380100R

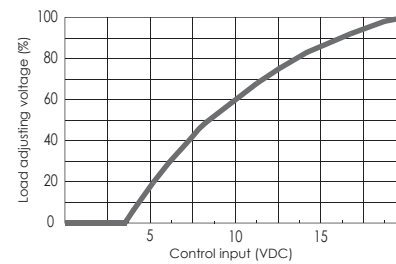

RS1API420mA240025R
RS1API420mA240040R
RS1API420mA380060R
RS1API420mA380080R
RS1API420mA380100R

Over 10 A load a heat sink must be used. The use of a heat sink will make the lifetime of the relay up to four times longer, even when using it with load currents lower than 10 A.

Dimensions (mm-inch)

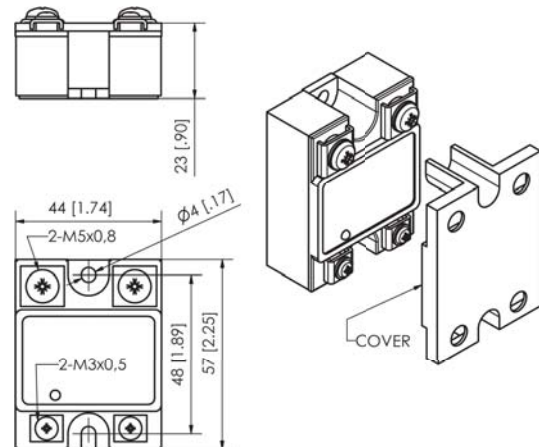

Diagrams

