



FEATURES

- > UL recognized for 1,500VDC.
- > Hermetically Sealed – Designed to meet: UL1604 for Class I & II, Div 2 and Class III for use in hazardous locations, IP67 for temporary water immersion for 30 min, SAE J1171 - external ignition protection, and ISO8846 for protection against ignition around flammable gasses.
- > Meets CE Conformance standards.
- > High Efficiency Dual DC Coils – Very low 12, 24, or 48VDC continuous coil power with no EMI emissions or cross-talk on your system control power. Ideal for battery powered systems or where low power is needed. PWM coil options provide additional drive control flexibility.
- > Built-in coil suppression for all DC coils – Saves you engineering time and parts cost to add external coil suppression.
- > Not position sensitive – can be mounted in any position for ease of installation.

PRODUCT SPECIFICATIONS

Specifications	Units	Data
Rated Voltage	V	1,500
Contact Arrangement		
Main	Form X	SPST-NO
Auxiliary ¹	Form A or B	SPST-NO or SPST-NC
Mechanical Life	cycles	1,000,000
Contact Resistance		
Max	mohms	0.4
Typical	mohms	0.3
Insulation Resistance²	Mohms	100
Dielectric at sea level (leakage < 1mA)	VRMS	5,375
Shock, 1/2 Sine, 11ms		
Actuated (closed)	G	50
Non Actuated (open)	G	25
Vibration, Sinusoidal (10-2000 Hz peak)	G	25
Environmental Seal	Exceeds IP67 & IP69K	
Salt Fog	MIL-STD-810	
Short Circuit Current (20ms)	A	4000
Max Break Current @ 400V (1 cycle)	A	3000
Max Break Current @ 800V (1 cycle)	A	900
Impulse Withstand Voltage	kV	8

POWER SWITCHING

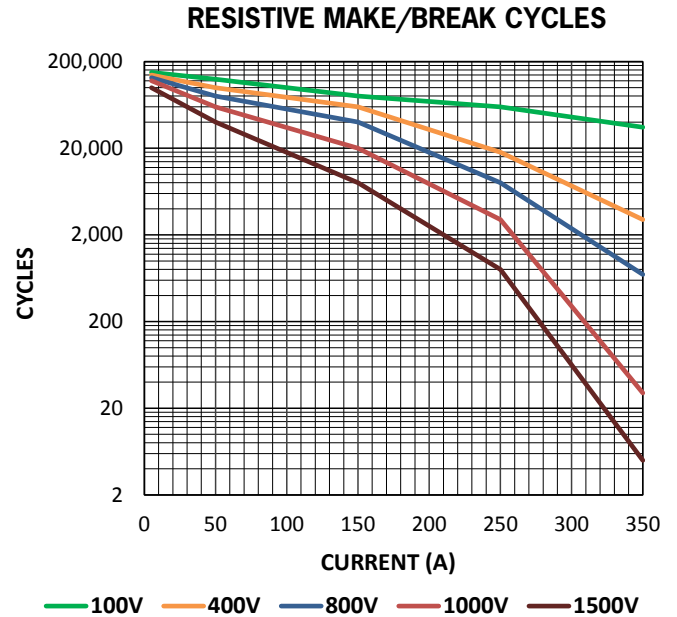

COIL RATINGS at 25°C

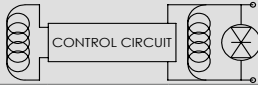
Coil P/N Designation	B ⁵	C ⁵	F ⁶
Coil Voltage, Nominal (VDC)	12	24	48
Coil Type	Dual	Dual	Dual
Coil Voltage, Max (V)³	16	32	64
Pick-Up Voltage, Max (V)^{3,4,5}	8	16	40
Drop-Out Voltage (V)³	0.5	2	4
Pick-Up Current, Max (A) (75 ms)^{3,4}	3.9	1.6	0.97
Coil Current (A)³	0.23	0.097	0.042
Coil Power (W)³	2.8	2.3	2
Operate Time, Max (ms)⁸	20		
Release Time, Max (ms)	12		
Internal Coil Suppression	TVS 		
Coil Back EMF (V)	55	55	125
Transients, Max (V) (13 ms)	±50	±50	±75
Reverse Polarity (V)	16	32	64

CURRENT CARRY RATINGS

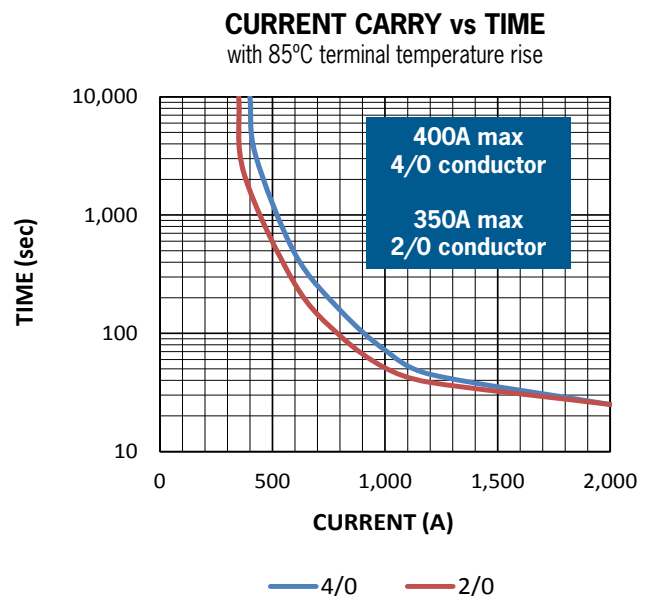



DIMENSIONS

Auxiliary Leads

B=SPST-NO
Blue Lead = T1
White Lead = T2
C=SPST-NC
Orange Lead = T1
White Lead = T2
(Refer to Part Number System on page 4)

Coil Leads

Red Lead = X1(+)
Black Lead = X2(-)
(Refer to Part Number System on page 4)

Upright Mounting

M5 or No. 10 Screws
Torque 1.7-4 Nm [15-35 in-lb]

Upright Power Connection

Silver Plated Copper M8x1.25 stud
Stainless M8x1.25 flanged nut
Torque 10 Nm [90 in-lb] max

PCB Mounting / Power Connection

M8x1.25 bolt
Torque 10 Nm [90 in-lb] max

Auxiliary contacts (optional)

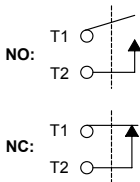

Power Contacts

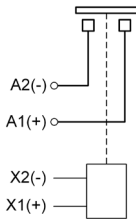

Temperature and Weight

Operating ambient Temp Range = -55 to +85°C
Storage ambient Temp Range = -70 to +150°C
Weight, typical without nuts and washers = 0.38 kg (0.84 lb)

Packaging

24 units per shipping box
21 in x 18 in x 4 in shipping box

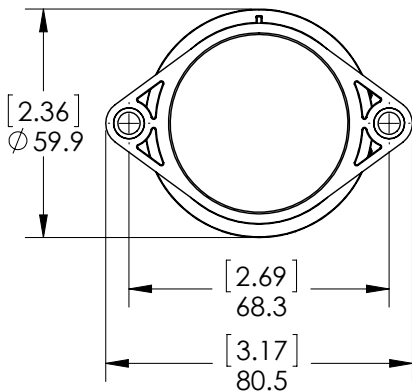
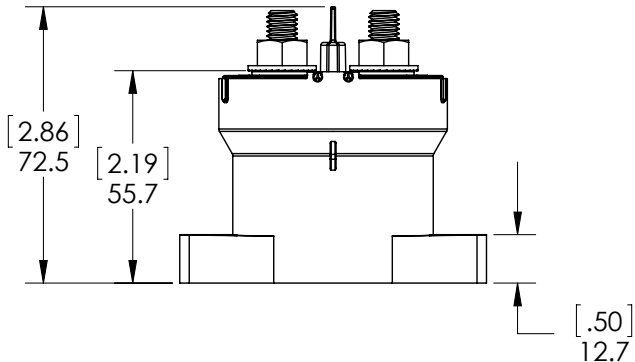
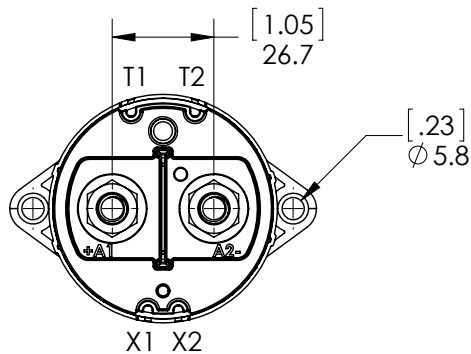

PART NUMBER SYSTEM

HX24	1	B	A	B
Mounting	1 = Upright			
Coil Voltage		B = 12 Vdc, internal coil suppression		
		C = 24 Vdc, internal coil suppression		
		F = 48 Vdc, internal coil suppression		
Coil Termination			A = Flying leads 38 cm (15 in)	
Auxiliary Contacts				X = None
				B = SPST-NO Normally Open
				C = SPST-NC Normally Closed

APPLICATION NOTES

- Contactors feature internal transient voltage suppressor for coil suppression. [No external diodes](#) should be added across the coil.
- Power switching lifecycles are based on [current flow](#) from A1(+) to A2(-). For best breaking performance, the contactor should be installed so that current flows from A1(+) to A2(-). There are cases where the contactor will interrupt power in the opposite direction but please contact GIGAVAC to confirm suitability. Direction of current flow is not relevant during make or when flowing on closed contacts. For bi-directional contactors, please contact GIGAVAC.
- Applications with [capacitors](#) will require a pre-charge circuit.
- Electrical life rating is based on resistive load with 27µH maximum inductance in circuit. Because your application may be different, we suggest you test the contactor in your circuit to verify life is as required.
- End of life is defined as when the dielectric, insulation resistance or contact resistance exceeds the specifications listed.

Notes & Definitions:

- 1 Auxillary contact rating is 2A, 24Vdc Resistive load, 100,000 cycles. Minimum current is 0.1mA, 5V. The auxiliary contact is mechanically linked to the main power contacts.
- 2 Insulation resistance is 50 Mohms after life.
- 3 Because the contactor is operated by a coil that changes resistance with temperature:

Maximum coil voltage will be lower than indicated at temperatures above 25°C, and higher than indicated at temperatures below 25°C.

And because Nominal Coil Voltage has been assumed for the Pick-up Current, Coil Current and Coil Power specifications, Current/Wattage will be lower than indicated at temperatures above 25°C and higher than indicated at temperatures below 25°C.

Pick-up Voltage and Drop Out Voltage will be lower than indicated at temperatures below 25°C and higher than indicated at temperatures above 25°C.
- 4 Contactor has two coils. Both are used for pick-up, and then in approximately 75 milliseconds, one coil is electronically removed from the coil drive circuit. The remaining coil supplies low continuous hold power sufficient for the contactor to meet all of its specified performance specifications. This provides the lowest coil power possible without the use of PWM electronics that have been known to cause EMI emissions and/or cross-talk on your system control power.
- 5 For Pick-up testing of contactors with dual coils, the voltage can not be ramped up slowly, but must be applied instantly to at least the maximum Pick-up Voltage or Current. Otherwise, the contactor will not pick-up.
- 6 These DC coils have built-in coil suppression. The use of additional external coil suppression can slow the release time and invalidate the life cycle ratings, or can cause the contactor not to be able to interrupt the maximum current specified. If lower coil back EMF is required, please contact GIGAVAC for assistance.
- 7 All contact ratings and coil versions may not be UL recognized. Contact GIGAVAC for a copy of the applicable sections of the test report.
- 8 Operation time is measured at 25°C and includes maximum 7mx bounce.