



POWER FACTOR CORRECTION EQUIPMENT

- POWER FACTOR CORRECTION CAPACITOR BANKS DECREASE ELECTRICAL ENERGY COSTS AND INCREASE SYSTEM VOLTAGE
- USING POWER CAPACITORS IS ONE OF THE MOST PRACTICAL SOLUTION TO INCREASE SYSTEM POWER QUALITY
- POWER CAPACITORS ARE A MAINTENANCE FREE AND INEXPENSIVE SOURCE OF REACTIVE ENERGY NEEDED IN EVERY INDUCTIVE ELECTRICAL SYSTEM

INDEX

KNK PFC CAPACITORS FOR LOW VOLTAGE

■ GENERAL	2
■ TERMS AND DEFINITIONS	4
■ INSTRUCTIONS FOR INSTALLATION, MAINTENANCE AND SAFE HANDLING	4
■ KNK5015 - CYLINDRICAL ALUMINIUM HOUSING (SINGLE-PHASE) KNK5065 - CYLINDRICAL ALUMINIUM HOUSING (THREE-PHASE)	6
■ KNK1053, KNK9053 - CYLINDRICAL ALUMINIUM HOUSING	9
■ KNK3053, KNK4053 - CYLINDRICAL ALUMINIUM HOUSING	14
■ KNK9103, KNK9143, KNK9101, KNK9141 - PRISMATIC	20
■ KNK9103, KNK9143 THREE-PHASE CAPACITORS - PRISMATIC	21
■ KNK9101, KNK9141 SINGLE-PHASE CAPACITORS - PRISMATIC	24

KLV HIGH VOLTAGE POWER CAPACITORS

■ GENERAL	26
■ KLV1XX1, KLV3XX1 SINGLE-PHASE CAPACITORS	28
■ KLV1XX3, KLV3XX3 THREE-PHASE CAPACITORS	29
■ KLV1XX4, KLV3XX4 SINGLE-PHASE CAPACITORS WITH TWO OUTPUTS (TWIN)	31

KLS INDUCTION HEATING CAPACITORS

■ GENERAL	34
■ KLSX0XX, KLSX1XX - AIR COOLED	35
■ KLSX2XX, KLSX3XX, KLSX4XX - WATER COOLED	36

CAPACITOR DUTY CONTACTORS

■ Kc12, Kc16, Kc20, Kc25, Kc33, Kc40, Kc60	40
--	----

POWER FACTOR CONTROL RELAY

■ PFCMAX 6, PFCMAX 12	42
■ PFC-CX	43

HARMONIC FILTER REACTORS

■ 3UI	45
-------------	----

PFC CAPACITORS FOR LOW VOLTAGE TYPE KNK



APPLICATIONS

THE KNK CAPACITORS ARE USED FOR POWER FACTOR CORRECTION OF INDUCTIVE CONSUMERS (TRANSFORMERS, ELECTRIC MOTORS, RECTIFIERS IN INDUSTRIAL NETWORKS FOR VOLTAGES OF UP TO 1000 V.

DESIGN

ISKRA KNK CAPACITORS ARE CONSTRUCTED BY THE MKP SYSTEM OF LOW-LOSS, METALIZED POLYPROPYLENE FILMS WITH A SPECIAL METALIZATION, WHOSE PURPOSE IS TO FAVOUR THE SELF-HEALING PROCESS AND REDUCE DIELECTRIC LOSSES.

ON THE END OF THE ELEMENT IS ZINC METAL SPRAYED TO MAKE CONTINUOUS GOOD ELECTRICAL CONTACT WITH ELECTRODE METALIZATION ON THE ELECTRIC. THREE SINGLE-PHASE ELEMENT ARE DELTA CONNECTED. AFTERWARDS ARE HERMETICALLY SEALED IN AL CASES. CAPACITORS ARE FILLED WITH WEGETABLE OIL BASED, NON TOXIC, PCB FREE, BIODEGRADABLE, ENVIRONMENTALLY FRIENDLY OR/AND DRY TYPE.

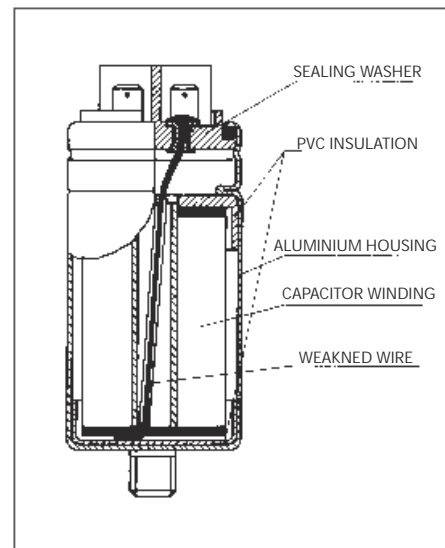

SELF-HEALING CAPACITY

DAMAGE MAY OCCUR ON THE DIELECTRIC DUE TO FATIGUE WHICH RESULTS IN LOCAL BREAKDOWNS ON CERTAIN POINTS. THE RESULTANT ELECTRIC CURRENT DEVAPORISES THE THIN METALLIZED LAYER AND ISOLATES THE DAMAGED SPOT FROM THE REST OF THE CAPACITOR. CAPACITANCE LOSS IS ALMOST NEGLIGIBLE (SOME PF) DURING THIS PROCESS. THIS SELF-HEALING PROPERTY GUARANTEES OPERATING RELIABILITY AND LONG LIFE EXPECTANCY OF THE CAPACITOR.

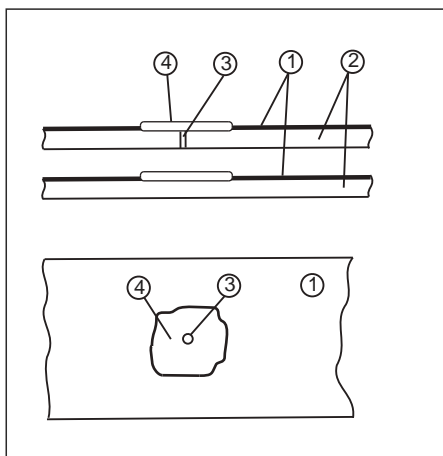

PFC CAPACITORS FOR LOW VOLTAGE TYPE KNK

DISCHARGE RESISTOR

CAPACITORS SHOULD BE DISCHARGED TO $\leq 10\%$ OF THE RATED VOLTAGE PRIOR TO BEING RE-ENERGIZED. KNK CAPACITORS ARE EQUIPPED WITH A RESISTOR THAT DISCHARGES THE CAPACITOR TO 75 V UNDER 3 MIN.

OVER-PRESSURE DISCONNECTOR

EVERY CAPACITOR IS PROTECTED AGAINST BREAKING BY THE OVERPRESSURE DISCONNECTOR, WHICH ENSURES SAFE DISCONNECTION OF THE CAPACITOR FROM THE NETWORK IN THE EVENT OF OVERLOADING AND AT THE END OF ITS OPERATIONAL LIFE.

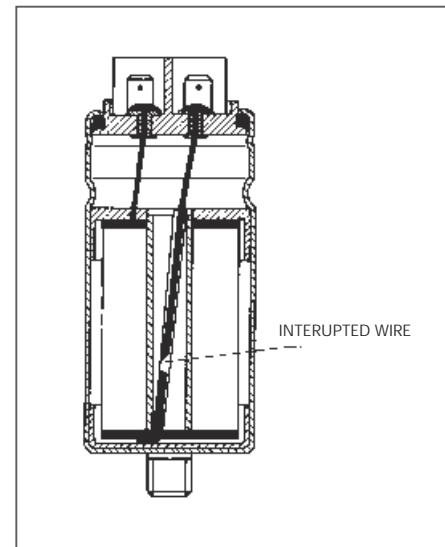

PFC CAPACITORS FOR LOW VOLTAGE TYPE KNK

TERMS AND DEFINITIONS

RATED CAPACITANCE OF A CAPACITOR C_n
CAPACITANCE VALUE FOR WHICH THE CAPACITOR HAS BEEN DESIGNED.

RATED OUTPUT OF A CAPACITOR Q_n
REACTIVE POWER DERIVED FROM THE RATED VALUES OF CAPACITANCE, FREQUENCY AND VOLTAGE.

RATED VOLTAGE OF A CAPACITOR U_n
MEAN OF THE MAX. PERMISSIBLE VALUE OF SINUSOIDAL AC VOLTAGE IN CONTINUOUS OPERATION.

RATED FREQUENCY OF A CAPACITOR f_n
FREQUENCY FOR WHICH THE CAPACITOR HAS BEEN DESIGNED.

RATED CURRENT OF A CAPACITOR I_n
RMS VALUE OF THE CURRENT AT RATED VOLTAGE AND FREQUENCY, EXCLUDING HARMONIC DISTORTION, CAPACITANCE TOLERANCE AND SWITCHING TRANSIENTS.

MAXIMUM PERMISSIBLE A.C. VOLTAGE OF A CAPACITOR U_{max}
MAXIMUM RMS VOLTAGE, WHICH THE CAPACITOR CAN BE EXPOSED TO PERMANENTLY.

MAXIMUM PERMISSIBLE A.C. CURRENT OF A CAPACITOR I_{max}
MAXIMUM RMS VALUE OF PERMISSIBLE CURRENT IN CONTINUOUS OPERATING. THE EXACT VALUE FOR EACH CAPACITOR CAN BE FOUND IN THE DATA CHARTS. HIGHER RMS VALUE THAN STATED IN THE DATA CHARTS REQUIRE ADJUSTMENTS IN CONSTRUCTION AND ARE AVAILABLE ON REQUEST.

AMBIENT AIR TEMPERATURE

TEMPERATURE OF THE AIR AT THE PROPOSED LOCATION OF THE CAPACITOR.

THE LOWEST AMBIENT TEMPERATURE AT WHICH A CAPACITOR MAY OPERATE, FOR ALL KNK CAPACITORS, IS -40°C. THE UPPER LIMIT TEMPERATURE IS INDICATED BY THE LETTER:

TEMPERATURE CLASSES (ACCORDING TO IEC 60831-1)

TEMPERATURE CLASS	AMBIENT TEMPERATURE °C		
	MAXIMUM	MAXIMUM MEAN FOR 24 H	MAXIMUM MEAN FOR 1 YEAR
A	40°C	30°C	20°C
B	45°C	35°C	25°C
C	50°C	40°C	30°C
D	55°C	45°C	35°C

INSTRUCTION FOR INSTALLATION, MAINTENANCE AND SAFE HANDLING OF CAPACITORS TYPE KNK

CAPACITORS CAN OPERATE SAFELY DURING ITS LIFE TIME ONLY IF ALL ELECTRICAL AND THERMAL CONDITIONS ARE IN COMPLIANCE WITH THE LABEL, DATA SHEET OR CATALOGUE.

RECEIVING

WHEN YOU RECEIVE CAPACITOR, MAKE SURE THAT NO MECHANICAL DAMAGE OCCURRED DURING TRANSPORT. SMALL DAMAGES, SUCH AS SCRATCHES WILL HAVE NO AFFECT ON QUALITY AND PERFORMANCE OF CAPACITOR. IF YOU RECEIVE CAPACITORS WITH LARGE DENTS OR BROKEN PARTS, PLEASE INFORM THE NEAREST SALES OFFICE FOR INSTRUCTIONS REGARDING THE DISPOSITION BEFORE INSTALLATION.

CHECK THE CAPACITOR NAMEPLATE TO MAKE SURE THAT THE SPECIFICATIONS ARE IN ACCORDANCE WITH THE CONTRACT.

INSTALLATION

IN GENERAL CAPACITORS MUST BE INSTALLED INDOORS. TYPE KNK105X, KNK305X, KNK405X CAN BE MOUNTED IN VERTICAL OR HORIZONTAL POSITION. TYPE KNK50XX KNK905X MUST BE MOUNTED VERTICALLY WITH TERMINALS UPRIGHT. WHILE INSTALLING MAKE SURE THAT THE MINIMUM SPACE BETWEEN CAPACITORS IS 20 mm AND THERE IS MINIMUM 25 mm ABOVE UPPER SIDE OF CAPACITOR TO ENABLE THE EXTENSION OF ALUMINUM CASE (IN CASE OF ABNORMAL OPERATION) AND CONSEQUENTIAL NORMAL OPERATION OF THE OVERPRESSURE DISCONNECTOR. AT THE BOTTOM OF EACH CAPACITOR CASE IS A MALE SCREW M12, WHICH IS INTENDED FOR MOUNTING AND PROTECTION EARTH. MAXIMUM ALLOWED TORQUE AT TIGHTENING A SCREW IS 10 Nm.

INRUSH CURRENT

SWITCHING CAPACITORS, ESPECIALLY WHEN THEY ARE IN PARALLEL WITH OTHERS CAN CAUSE HIGH INRUSH CURRENTS OF UP TO 200 TIMES OF NOMINAL CURRENT. THESE SHOCKS CAUSE ADDITIONAL STRESS TO CAPACITOR AND HAVE BAD INFLUENCE ON USEFUL LIFE. IT IS NECESSARY TO LIMIT INRUSH CURRENTS.

PFC CAPACITORS FOR LOW VOLTAGE TYPE KNK

ELECTRICAL CONNECTION

CONNECTIONS TO THE CAPACITOR TERMINALS MUST BE MADE WITH INSULATED FLEXIBLE COPPER CONDUCTORS. CONDUCTORS MUST HAVE A PROPER CROSS SECTION FOR EXPECTED CAPACITOR CURRENTS INCLUDING OVERLOADS. CONDUCTORS HAVE TO BE EQUIPPED WITH END SLEEVES OR CABLE LUGS IN CASE OF SCREW TERMINALS. WHEN COUPLING THE CAPACITORS IN PARALLEL DO NOT EXCEED THE MAXIMAL CURRENT PER CONTACT.

DO NOT SOLDER LEADS TO THE TERMINALS. CHECK CONNECTIONS PERIODICALLY TO AVOID WEAK CONNECTIONS AND OVERHEATING OF THE CONNECTING POINTS. WITH OUR 16 AND 25 mm² TERMINALS USE ONLY PH1 SCREWDRIVERS.

AMBIENT TEMPERATURE

THE CAPACITORS ARE DESIGNED TO OPERATE CONTINUOUSLY IN A TEMPERATURE RANGE -25 °C TO 55 °C. CAPACITORS CAN ALSO OPERATE CONTINUOUSLY AT LOWER TEMPERATURE, DOWN TO -40 °C. IF THE TEMPERATURE DROPS TO LESS THAN -40 °C THE CAPACITORS SHOULD NOT BE ENERGIZED, BECAUSE THERE IS POSSIBILITY OF DAMAGE. MAINTAIN PROPER AMBIENT TEMPERATURES AND TAKE CARE OF SUFFICIENT HEAT DISSIPATION.

DISCHARGE OF CAPACITORS

BECAUSE OF THE RESIDUAL VOLTAGE ALWAYS DISCHARGE AND SHORT CIRCUIT THE CAPACITOR BEFORE TOUCHING THE TERMINALS. OUR CAPACITORS ARE DISCHARGED TO 75 V UNDER 3 MIN AND THEY MUST BE DISCHARGED TO 10 % OF THE RATED VOLTAGE BEFORE RE-ENERGIZING. DISCHARGE RESISTOR MAY BECOME VERY HOT DURING OPERATION.

IN CASE THE REQUIRED TIME BETWEEN SWITCHING OFF AND REPEATED SWITCHING ON HAVE TO BE SHORTER THAN 3 MINUTES (MOSTLY APPLICATION IN AUTOMATIC CAPACITOR BANKS), CAPACITORS MUST BE ADDITIONALLY DISCHARGED BY OTHER MEASURES, EXAMPLE FAST DISCHARGE REACTORS OR FAST DISCHARGE RESISTORS.

HARMONICS

HIGHER HARMONICS MAY BE PRESENT IN SOME APPLICATIONS AND CAN AFFECT THE USEFUL LIFE OF A CAPACITOR. IN SUCH CASES CAPACITORS OR CAPACITOR DEVICES MUST BE CONNECTED WITH SUITABLE REACTORS.

PROTECTION AGAINST SHOCK

BEFORE MAINTENANCE OR ANY CONTACT OF THE CAPACITORS MAKE SURE THAT CAPACITORS OR CAPACITOR DEVICE ARE PHYSICALLY DISCONNECTED FROM THE POWER SOURCE. CAPACITORS HAVE AN INTERNAL OR EXTERNAL DISCHARGE RESISTORS TO REDUCE VOLTAGE TO 75 V OR LESS IN THREE MINUTES, AFTER THE POWER IS SWITCHED OFF.

WAIT FIVE MINUTES, THEN THE CAPACITORS MUST BE SHORTED AND GROUNDED BY USING A SHORT STICK WITH INSULATED HANDLE. MAKE SURE THAT ALL SAFETY PRECAUTIONS ARE MADE BEFORE HANDLING THE CAPACITOR.

FIRE HAZARD

CAPACITORS ARE NOT FLAMMABLE, BUT THERE IS A POSSIBILITY OF IGNITION IN A CASE OF EXPLOSION, IF THE ELECTRICAL CURRENT IS PRESENT.

IT MUST BE CONSIDERED, THAT THE CAPACITORS AND CAPACITOR DEVICES ARE LOCATED IN SUCH POSITION THAT POSSIBLE DAMAGE OF CAPACITOR WILL NOT DAMAGE THE SURROUNDING AREA.

EXPLOSION HAZARD

ALL CAPACITORS HAVE INTERNAL OVERPRESSURE DISCONNECTORS ON ALL THREE TERMINALS. IN EXTREME SITUATIONS IT IS POSSIBLE TO GET AN EXPLOSIVE CASE RUPTURE, EVEN WITH PROPER FUSING.

THESE FACTS SHOULD BE CONSIDERED WHEN LOCATING THE CAPACITORS AND CAPACITOR DEVICES.

HANDLING OF FAILED CAPACITORS

FAILED CAPACITORS SHOULD BE SHORT CIRCUITED BEFORE HANDLING.

CAPACITORS WHICH ARE VISUALLY DAMAGED MUST BE CAREFULLY REMOVED FROM THE PLACE OF INSTALLATION. CAPACITORS DO NOT CONTAIN ECOLOGICALLY HARMFUL SUBSTANCES AND CAN BE DEPOSITED TO AN INDUSTRIAL DUMP.

WARRANTY

IN CASE OF A CLAIM IN AN IN-WARRANTY PERIOD, THE USER SHOULD PROVIDE ALL INFORMATION IN ACCORDANCE WITH THE TERMS OF THE WARRANTY, TO THE SELLER.

THIS INFORMATION IS:

MANUFACTURING DATE, DESCRIPTION OF THE FAILURE, TIME OF THE OPERATION, DATE AND TIME OF THE FAILURE, WHETHER THE CAPACITOR WAS OPERATING CONTINUOUSLY OR THERE WERE MULTIPLE SWITCHING, CONDITIONS AT THE TIME OF THE FAILURE.

DO NOT DISPOSE OF AN IN-WARRANTY CAPACITOR BEFORE GETTING AN APPROVAL FROM A PERSON AUTHORIZED BY THE MANUFACTURER.

PFC CAPACITORS FOR LOW VOLTAGE

KNK5015, KNK5065

TECHNICAL DATA				
TYPE	SYMBOL	UNIT	KNK5015	KNK5065
STANDARDS			IEC/EN 60831-1/2, UL 810 APPROVAL (E163120)	
CONNECTION			SINGLE PHASE	DELTA (THREE-PHASE)
RATED REACTIVE POWER	Q_n	kVar		UP TO 7.5
RATED VOLTAGE	U_n	V		400 ~ 525
RATED FREQUENCY	f_n	Hz		50 OR 60
CAPACITANCE TOLERANCE			-5/10 % (OTHER ON REQUEST)	
DIELECTRIC LOSES		W/kVar	≤ 0.2	
TOTAL LOSES		W/kVar	≤ 0.45	
TEMPERATURE CATEGORY			-25/D	
MAX. HUMIDITY			95 %	
COOLING			FORCED VENTILATION OR NATURAL AIR COOLED	
MAX. OVERVOLTAGE			1.1 x U_n (8 h/DAY)	
			1.15 x U_n (30 min/DAY)	
			1.2 x U_n (5 min - 200 TIMES PER LIFE TIME)	
			1.3 x U_n (1 min - 200 TIMES PER LIFE TIME)	
MAX. OVERCURRENT			1.3 x I_n (INCLUDING COMBINED EFFECTS OF OVERVOLTAGES, HARMONICS AND CAPACITANCE TOLERANCE)	
INRUSH CURRENT			150 x I_n	
EXPECTED LIFE TIME			> 100000 h (TEMP. CATEGORY D)	
			> 120000 h (TEMP. CATEGORY C)	
DISCHARGE RESISTOR			TO 75 V ≤ 3 min	
ALTITUDE			UP TO 4000 m	
INSULATION LEVEL		kV	3.6/-	
ROUTINE TESTS				
TERMINAL TO TERMINAL			2.15 x U_n , 2 s	
TERMINAL TO CASE			3600 V, 10 s	
SEALING TEST			75 °C, 6 h	
MECHANICAL PARAMETERS				
TERMINAL PER PHASE / MAX. CURRENT			2.5 mm ² / 15 A	
MOUNTING AND GROUNDING / MAX. TORQUE			THREADED M12 BOLT /10 Nm	
MOUNTING POSITION			VERTICAL WITH TERMINAL POINTING UPWARDS OR HORIZONTAL	
PROTECTION			IP00	
CLEARANCE DISTANCE			> 10 mm	
CREEPAGE DISTANCE			> 10 mm	
SAFETY DEVICE			OVERPRESSURE DISCONNECTOR	
MATERIAL PARAMETERS				
DIELECTRIC			SELF HEALING METALLIZED POLYPROPYLENE FILM	
FILLING			NON PCB BIODEGRADABLE VEGETABLE OIL	
CASE			ALUMINIUM	

Notes:

ON REQUEST, CAPACITORS WITH OTHER POWER AND VOLTAGE RATINGS, SHAPES, AND CONNECTIONS ARE AVAILABLE.

- ALL RIGHTS RESERVED FOR ANY POSSIBLE CHANGES.
- IN-RUSH CURRENT MUST BE LIMITED TO MAXIMAL PERMITTED VALUE.

PFC CAPACITORS FOR LOW VOLTAGE (SINGLE-PHASE)

KNK5015 - CYLINDRICAL ALUMINIUM HOUSING



230 ... 525 V, 1.67 ... 6.25 kVar

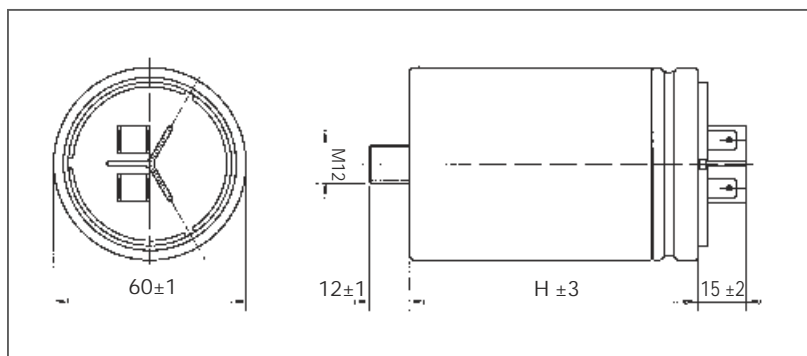

$f_n = 50 \text{ Hz}$

U_n (V)	Q_n (kVar)	C_n (μF)	I_n (A)	H (mm)	Weight (kg)	Packing unit (pcs)
400	1.67	33.2	4.2	75	0.22	36
400	2.1	41.6	5.2	87	0.27	36
400	2.5	49.7	6.2	87	0.27	36
400	3.33	66.3	8.3	110	0.32	36
400	4.17	82.9	10.4	125	0.40	36
400	5	99.5	12.5	150	0.45	36
440	1.67	27	3.8	75	0.22	36
440	2.5	41.1	5.7	110	0.32	36
440	3.33	54.8	7.6	110	0.32	36
440	4.17	68.5	9.5	150	0.45	36
440	5	82.2	11.4	150	0.45	36
480	1.67	23.1	3.5	75	0.22	36
480	2.1	29	4.4	75	0.22	36
480	2.5	34.5	5.2	87	0.27	36
480	3.33	46	6.9	100	0.30	36
480	4.17	57.6	8.7	125	0.40	36
480	5	69.1	10.4	150	0.45	36
525	1.67	19.3	3.1	75	0.22	36
525	2.5	28.0	4.8	100	0.30	36
525	3.33	38.5	6.3	125	0.40	36
525	4.17	48.2	7.3	150	0.45	36

$f_n = 60 \text{ Hz}$

U_n (V)	Q_n (kVar)	C_n (μF)	I_n (A)	H (mm)	Weight (kg)	Packing unit (pcs)
400	1.67	27.2	4.2	75	0.22	36
400	3.33	55.2	8.3	100	0.30	36
400	4.17	69.1	10.4	110	0.32	36
400	5	82.9	12.5	125	0.40	36
440	1.67	22.8	3.8	75	0.22	36
440	3.33	45.4	7.5	110	0.32	36
440	4.17	56.9	9.4	125	0.40	36
440	5	68.4	11.3	150	0.45	36
480	1.67	19.2	3.5	75	0.22	36
480	3.33	38.3	6.9	87	0.27	36
480	4.17	48	8.7	100	0.30	36
480	5	57.6	10.4	125	0.40	36
525	1.67	16.1	3.2	75	0.22	36
525	3.33	32	6.3	100	0.30	36
525	4.17	40.1	7.9	110	0.32	36
525	5	48.1	9.5	125	0.40	36
525	6.25	60.2	11.9	150	0.45	36

PFC CAPACITORS FOR LOW VOLTAGE (THREE-PHASE)

KNK5065 - CYLINDRICAL ALUMINIUM HOUSING, DELTA CONNECTION



400 ... 525 V, 2.5 ... 7.5 kVar

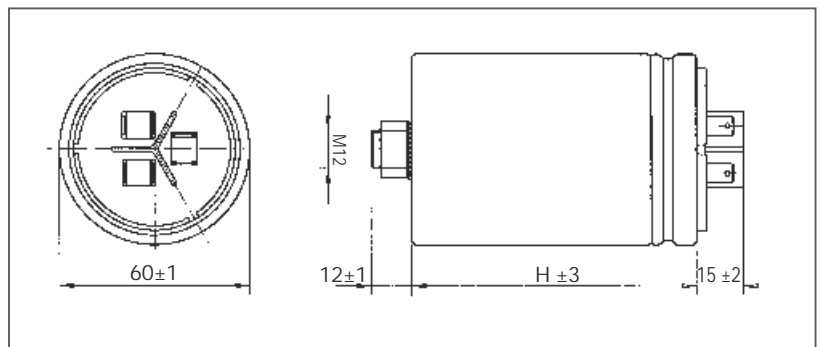

$f_n = 50 \text{ Hz}$

U_n (V)	Q_n (kVar)	C_n (μF)	I_n (A)	H (mm)	Weight (kg)	Packing unit (pcs)
400	2.5	3 x 16.6	3.6	145	0.45	36
400	3	3 x 19.9	4.3	145	0.45	36
400	4	3 x 26.5	5.8	185	0.55	36
400	5	3 x 33.2	7.2	185	0.55	36
400	7.5	3 x 49.7	10.8	185	0.55	36
440	2.5	3 x 13.7	3.3	145	0.45	36
440	3	3 x 16.5	3.9	145	0.45	36
440	4	3 x 21.9	5.3	185	0.55	36
440	5	3 x 27.4	6.6	185	0.55	36
480	2.5	3 x 11.5	3.0	145	0.45	36
480	3	3 x 13.8	3.6	145	0.45	36
480	4	3 x 18.4	4.8	145	0.45	36
480	5	3 x 23	6.0	185	0.55	36
480	6.25	3 x 28.8	7.5	185	0.55	36
525	2.5	3 x 9.6	2.7	145	0.45	36
525	3	3 x 11.5	3.3	145	0.45	36
525	4	3 x 15.4	4.4	185	0.55	36
525	5	3 x 19.3	5.5	185	0.55	36
525	7.5	3 x 28.9	8.2	185	0.55	36

PFC CAPACITORS FOR LOW VOLTAGE (THREE-PHASE)

KNK1053, KNK9053 - CYLINDRICAL ALUMINIUM HOUSING

TECHNICAL DATA				
TYPE	SYMBOL	UNIT	KNK1053	KNK9053
STANDARDS			IEC/EN 60831-1/2	
CONNECTION			DELTA (THREE-PHASE)	
RATED REACTIVE POWER	Q_n	kVar	UP TO 30	
RATED VOLTAGE	U_n	V	400 ~ 690	
RATED FREQUENCY	f_n	Hz	50 OR 60	
CAPACITANCE TOLERANCE			-5/10 % (OTHER ON REQUEST)	
DIELECTRIC LOSES		W/kVar	≤ 0.2	
TOTAL LOSES		W/kVar	≤ 0.45	
TEMPERATURE CATEGORY			-25/D	
MAX. HUMIDITY			95 %	
COOLING			FORCED VENTILATION OR NATURAL AIR COOLED	
MAX. OVERVOLTAGE			1.1 X U_n (8 H/DAY)	
			1.15 X U_n (30 MIN/DAY)	
			1.2 X U_n (5 min - 200 TIMES PER LIFE TIME)	
			1.3 X U_n (1 min - 200 TIMES PER LIFE TIME)	
MAX. OVERCURRENT			1.7 X I_n (INCLUDING COMBINED EFFECTS OF OVERVOLTAGES, HARMONICS AND CAPACITANCE TOLERANCE)	
INRUSH CURRENT			200 X I_n	
EXPECTED LIFE TIME			> 130000 h	
DISCHARGE RESISTOR			TO 75 V ≤ 3 min	
ALTITUDE			UP TO 2000 m	
INSULATION LEVEL		kV	3.6/-	
ROUTINE TESTS				
TERMINAL TO TERMINAL			2.15 X U_n , 2 s	
TERMINAL TO CASE			3600 V, 10 s	
SEALING TEST			N/A	75 °C, 6 h
MECHANICAL PARAMETERS				
TERMINAL PER PHASE / MAX. TORQUE / MAX. CURRENT			2 x 25 mm ² / 3 Nm / 60 A	
MOUNTING AND GROUNDING / MAX. TORQUE			THREADED M12 BOLT /10 Nm	
MOUNTING POSITION			VERTICAL WITH TERMINAL POINTING UPWARDS OR HORIZONTAL	VERTICAL WITH TERMINAL POINTING UPWARDS
PROTECTION			IP20	
CLEARANCE DISTANCE			> 16 mm	
CREEPAGE DISTANCE			> 16 mm	
SAFETY DEVICE			OVERPRESSURE DISCONNECTOR (ALL PHASES)	
MATERIAL PARAMETERS				
DIELECTRIC			SELF HEALING METALLIZED POLYPROPYLENE FILM	
FILLING			DRY	NON PCB BIODEGRADABLE VEGETABLE OIL
CASE			ALUMINIUM	

PFC CAPACITORS FOR LOW VOLTAGE (THREE-PHASE)

KNK1053 - CYLINDRICAL ALUMINIUM HOUSING



400 ... 690 V, 10 ... 40 kVar

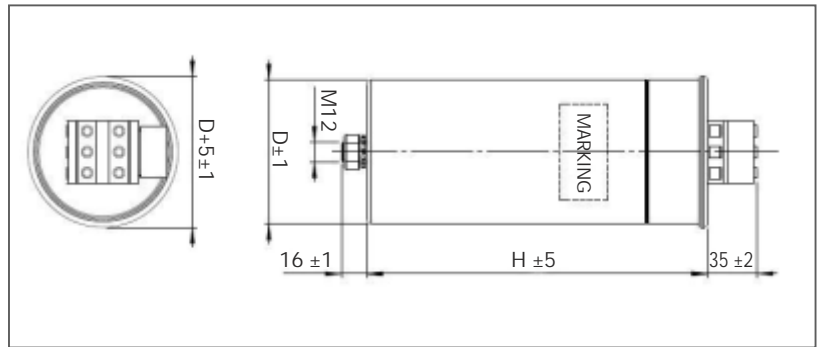

$f_n = 50 \text{ Hz}$ - DELTA CONNECTION

C_n (μF)	Q_n (kVar)	I_n (A)	Q_n (kVar)	I_n (A)	Q_n (kVar)	I_n (A)	H (mm)	D (mm)	Weight (kg)	Packing unit (pcs)
$U_n = 400 \text{ V}$		$U_n = 400 \text{ V}$		$U_n = 380 \text{ V}$						
3 x 66.3	10	14.4	9	13.7			205	90	1.2	16
3 x 83.3	12.5	18	11.3	17.2			205	90	1.2	16
3 x 100	15	21.7	13.6	20.7			240	90	1.4	16
3 x 133	20	28.9	18.1	27.5			205	116	1.6	9
3 x 165.8	25	36.1	22.6	34.3			240	116	1.9	9
3 x 198.9	30	43.3	27.1	41.2			240	116	1.9	9
$U_n = 440 \text{ V}$		$U_n = 440 \text{ V}$		$U_n = 420 \text{ V}$		$U_n = 400 \text{ V}$				
3 x 54.9	10	13.1	9.1	12.5	8.3	12	205	90	1.2	16
3 x 68.6	12.5	16.4	11.5	15.8	10.4	15	205	90	1.2	16
3 x 82.3	15	19.7	13.7	18.8	12.4	17.9	240	90	1.4	16
3 x 110	20	26.2	18.3	25.2	16.6	24	205	116	1.6	9
3 x 137.1	25	32.8	22.8	31.3	20.7	29.9	240	116	1.9	9
3 x 164.4	30	39.4	27.3	37.5	24.8	35.8	280	116	2.3	9
$U_n = 480 \text{ V}$		$U_n = 480 \text{ V}$		$U_n = 440 \text{ V}$		$U_n = 440 \text{ V}$				
3 x 46.1	10	12	8.4	11	7	10.1	160	90	0.9	16
3 x 57.6	12.5	15	10.5	13.8	8.6	12.4	205	90	1.2	16
3 x 69.1	15	18	12.7	16.7	10.5	15.2	205	90	1.2	16
3 x 92.1	20	24	16.9	22.2	13.9	20.1	205	116	1.6	9
3 x 115.1	25	30.1	21	27.6	17.4	25.1	205	116	1.6	9
3 x 138.2	30	36.1	25.2	33.1	20.8	30	240	116	1.9	9
$U_n = 525 \text{ V}$		$U_n = 525 \text{ V}$		$U_n = 460 \text{ V}$		$U_n = 440 \text{ V}$				
3 x 38.5	10	11	7.7	9.7	7	9.2	205	90	1.2	16
3 x 48.2	12.5	13.8	9.6	12	8.8	11.5	240	90	1.4	16
3 x 57.8	15	16.5	11.5	14.4	10.5	13.8	240	90	1.4	16
3 x 77	20	22	15.3	19.2	14	18.4	205	116	1.6	9
3 x 96.3	25	27.5	19.2	24.1	17.6	23.1	240	116	1.9	9
3 x 115.5	30	33	23	28.9	21.1	27.7	240	116	1.9	9
3 x 154	40	44	30.6	38.4	28	36.8	305	136	2.3	1
$U_n = 690 \text{ V}$										
3 x 11.1	5	4.2					160	90	1.1	16
3 x 16.7	7.5	6.3					160	90	1.1	16
3 x 22.3	10	8.4					205	90	1.6	16
3 x 28	12.5	10.5					240	90	1.6	16
3 x 44.6	20	17					205	116	1.9	9
3 x 56	25	21					240	116	1.9	9
3 x 74	33	27.7					280	116	2.5	9

PFC CAPACITORS FOR LOW VOLTAGE (THREE-PHASE)

KNK1053 - CYLINDRICAL ALUMINIUM HOUSING

$f_n = 60 \text{ Hz}$

C_n (μF)	Q_n (kVar)	I_n (A)	Q_n (kVar)	I_n (A)	Q_n (kVar)	I_n (A)	H (mm)	D (mm)	Weight (kg)	Packing unit (pcs)
$U_n = 400 \text{ V}$	$U_n = 400 \text{ V}$		$U_n = 380 \text{ V}$							
3 x 55.3	10	14.4	9	13.7			160	90	0.9	16
3 x 69.7	12.5	18	11.3	17.2			205	90	1.2	16
3 x 82.9	15	21.7	13.6	20.7			205	90	1.2	16
3 x 110.5	20	28.9	18.1	27.5			280	90	1.4	16
3 x 138.2	25	36.1	22.6	34.3			205	116	1.6	9
3 x 165.8	30	43.3	27.1	41.2			240	116	1.9	9
$U_n = 440 \text{ V}$	$U_n = 440 \text{ V}$		$U_n = 420 \text{ V}$		$U_n = 400 \text{ V}$					
3 x 45.7	10	13.1	9.1	12.5	8.3	12	160	90	0.9	16
3 x 57.1	12.5	16.4	11.5	15.8	10.4	15	205	90	1.2	16
3 x 68.5	15	19.7	13.7	18.8	12.4	17.9	205	90	1.2	16
3 x 91.3	20	26.2	18.3	25.2	16.6	24	240	90	1.4	16
3 x 114.2	25	32.8	22.8	31.3	20.7	29.9	205	116	1.6	9
3 x 137	30	39.4	27.3	37.5	24.8	35.8	240	116	1.6	9
$U_n = 480 \text{ V}$	$U_n = 480 \text{ V}$		$U_n = 440 \text{ V}$		$U_n = 440 \text{ V}$					
3 x 38.4	10	12	8.5	11.1	7	10	160	90	0.9	16
3 x 48	12.5	15	10.7	14	8.8	12.7	205	90	1.2	16
3 x 57.6	15	18	12.8	16.7	10.3	14.9	205	90	1.2	16
3 x 76.7	20	24	17	22.3	14	20.2	240	90	1.4	16
3 x 96	25	30	21	27.6	17.3	25	205	116	1.6	9
3 x 115.1	30	36	25	33	21	30	205	116	1.6	9
$U_n = 525 \text{ V}$	$U_n = 525 \text{ V}$		$U_n = 460 \text{ V}$		$U_n = 440 \text{ V}$					
3 x 21.1	10	11	7.7	9.7	7	9.2	160	90	0.9	16
3 x 40.1	12.5	13.8	9.6	12	8.8	11.5	205	90	1.2	16
3 x 48.1	15	16.5	11.5	14.4	10.5	13.8	205	90	1.2	16
3 x 64.2	20	22	15.3	19.2	14	18.4	240	90	1.4	9
3 x 80.2	25	27.5	19.2	24.1	17.6	23.1	205	116	1.6	9
3 x 96.2	30	33	23	28.9	21.1	27.7	240	116	1.9	9
3 x 128.3	40	44	30.6	38.4	28	36.8	305	136	3.1	1

PFC CAPACITORS FOR LOW VOLTAGE (THREE-PHASE)

KNK9053 - CYLINDRICAL ALUMINIUM HOUSING



400 ... 690 V, 10 ... 30 kVar

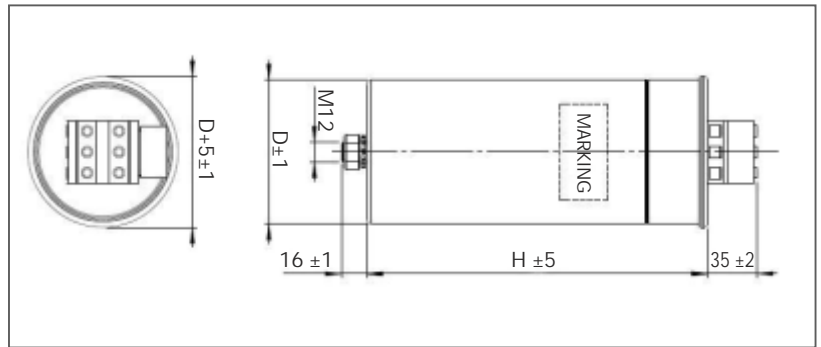

$f_n = 50 \text{ Hz}$ - DELTA CONNECTION

C_n (μF)	Q_n (kVar)	I_n (A)	Q_n (kVar)	I_n (A)	Q_n (kVar)	I_n (A)	H (mm)	D (mm)	Weight (kg)	Packing unit (pcs)
$U_n = 400 \text{ V}$		$U_n = 400 \text{ V}$		$U_n = 380 \text{ V}$						
3 x 66.3	10	14.4	9	13.7			205	90	1.35	16
3 x 83.3	12.5	18	11.3	17.2			205	90	1.35	16
3 x 100	15	21.7	13.6	20.7			240	90	1.6	16
3 x 133	20	28.9	18.1	27.5			205	116	1.9	9
3 x 165.8	25	36.1	22.6	34.3			240	116	2.2	9
3 x 198.9	30	43.3	27.1	41.2			240	116	2.2	9
$U_n = 440 \text{ V}$		$U_n = 440 \text{ V}$		$U_n = 420 \text{ V}$		$U_n = 400 \text{ V}$				
3 x 54.9	10	13.1	9.1	12.5	8.3	12	205	90	1.35	16
3 x 68.6	12.5	16.4	11.5	15.8	10.4	15	205	90	1.35	16
3 x 82.3	15	19.7	13.7	18.8	12.4	17.9	240	90	1.6	16
3 x 110	20	26.2	18.3	25.2	16.6	24	205	116	1.9	9
3 x 137.1	25	32.8	22.8	31.3	20.7	29.9	240	116	2.2	9
3 x 164.4	30	39.4	27.3	37.5	24.8	35.8	280	116	2.6	9
$U_n = 480 \text{ V}$		$U_n = 480 \text{ V}$		$U_n = 440 \text{ V}$		$U_n = 440 \text{ V}$				
3 x 46.1	10	12	8.4	11	7	10.1	205	90	1.35	16
3 x 57.6	12.5	15	10.5	13.8	8.6	12.4	205	90	1.35	16
3 x 69.1	15	18	12.7	16.7	10.5	15.2	240	90	1.6	16
3 x 92.1	20	24	16.9	22.2	13.9	20.1	205	116	1.9	9
3 x 115.1	25	30.1	21	27.6	17.4	25.1	240	116	2.2	9
3 x 138.2	30	36.1	25.2	33.1	20.8	30	240	116	2.2	9
$U_n = 525 \text{ V}$		$U_n = 525 \text{ V}$		$U_n = 460 \text{ V}$		$U_n = 440 \text{ V}$				
3 x 38.5	10	11	7.7	9.7	7	9.2	205	90	1.35	16
3 x 48.2	12.5	13.8	9.6	12	8.8	11.5	205	90	1.6	16
3 x 57.8	15	16.5	11.5	14.4	10.5	13.8	240	90	1.6	16
3 x 77	20	22	15.3	19.2	14	18.4	205	116	1.9	9
3 x 96.3	25	27.5	19.2	24.1	17.6	23.1	240	116	2.2	9
3 x 115.5	30	33	23	28.9	21.1	27.7	240	116	2.2	9
$U_n = 690 \text{ V}$										
3 x 11	5	4.2					160	90	1.1	16
3 x 16	7.5	6.3					160	90	1.1	16
3 x 22	10	8.4					240	90	1.6	16
3 x 28	12.5	10.5					240	90	1.6	16
3 x 46	20	17					240	116	1.9	9
3 x 56	25	21					240	116	1.9	9
3 x 74	33	27.7					280	116	2.5	9

PFC CAPACITORS FOR LOW VOLTAGE (THREE-PHASE)

KNK9053 - CYLINDRICAL ALUMINIUM HOUSING

$f_n = 60 \text{ Hz}$

C_n (μF)	Q_n (kVar)	I_n (A)	Q_n (kVar)	I_n (A)	Q_n (kVar)	I_n (A)	H (mm)	D (mm)	Weight (kg)	Packing unit (pcs)
$U_n = 400 \text{ V}$										
3×55.3	10	14.4	9	13.7			160	90	1.05	16
3×69.7	12.5	18	11.3	17.2			205	90	1.35	16
3×82.9	15	21.7	13.6	20.7			205	90	1.35	16
3×110.5	20	28.9	18.1	27.5			280	90	1.6	16
3×138.2	25	36.1	22.6	34.3			205	116	1.9	9
3×165.8	30	43.3	27.1	41.2			240	116	2.2	9
$U_n = 440 \text{ V}$										
3×45.7	10	13.1	9.1	12.5	8.3	12	160	90	1.05	16
3×57.1	12.5	16.4	11.5	15.8	10.4	15	205	90	1.35	16
3×68.5	15	19.7	13.7	18.8	12.4	17.9	205	90	1.35	16
3×91.3	20	26.2	18.3	25.2	16.6	24	240	90	1.6	16
3×114.2	25	32.8	22.8	31.3	20.7	29.9	205	116	1.9	9
3×137	30	39.4	27.3	37.5	24.8	35.8	240	116	2.2	9
$U_n = 480 \text{ V}$										
3×38.4	10	12	8.5	11.1	7	10	160	90	0.9	16
3×48	12.5	15	10.7	14	8.8	12.7	205	90	1.2	16
3×57.6	15	18	12.8	16.7	10.3	14.9	205	90	1.2	16
3×76.7	20	24	17	22.3	14	20.2	240	90	1.4	16
3×96	25	30	21	27.6	17.3	25	205	116	1.6	9
3×115.1	30	36	25	33	21	30	205	116	1.6	9
$U_n = 525 \text{ V}$										
3×14.3	4.5	5	3.4	4.3	4.1		160	90	1.2	16
3×16.8	5.2	5.7	4	5	4.9		160	90	1.2	16
3×23.6	7.4	8.1	5.6	7	6.8		160	90	1.2	16
3×32.1	10	11	7.7	9.7	7	9.2	160	90	1.2	16
3×40.1	12.5	13.8	9.6	12	8.8	11.5	205	90	1.35	16
3×48.1	15	16.5	11.5	14.4	10.5	13.8	205	90	1.35	16
3×64.2	20	22	15.3	19.2	14	18.4	205	116	1.9	9
3×80.2	25	27.5	19.2	24.1	17.6	23.1	240	116	2.2	9
3×96.2	30	33	23	28.9	21.1	27.7	240	116	2.2	9
$U_n = 690 \text{ V}$										
3×18.6	10	8.4					160	90	1.6	16
3×23.2	12.5	10.5					205	90	1.6	16
3×37.1	20	16.7					205	90	2.2	9
3×46.4	25	21					240	90	2.6	9
3×55.7	33	25.1					205	116	2.6	9

PFC CAPACITORS FOR LOW VOLTAGE (THREE-PHASE)

KNK3053, KNK4053 - CYLINDRICAL ALUMINIUM HOUSING

TECHNICAL DATA				
TYPE	SYMBOL	UNIT	KNK3053	KNK4053
STANDARDS			IEC/EN 60831-1/2	
CONNECTION			DELTA (THREE-PHASE)	
RATED REACTIVE POWER	Q_n	kVar	UP TO 50	
RATED VOLTAGE	U_n	V	220 - 800	
RATED FREQUENCY	f_n	Hz	50 OR 60	
CAPACITANCE TOLERANCE			-5/10 % (OTHER ON REQUEST)	
DIELECTRIC LOSSES		W/kVar	≤ 0.2	
TOTAL LOSSES		W/kVar	≤ 0.45	
TEMPERATURE CATEGORY			-40/D	
MAX. HUMIDITY			95 %	
COOLING			FORCED VENTILATION OR NATURAL AIR COOLED	
MAX. OVERVOLTAGE			1.1 X U_n (8 h/DAY)	
			1.15 X U_n (30 min/DAY)	
			1.2 X U_n (5 min - 200 TIMES PER LIFE TIME)	
			1.3 X U_n (1 min - 200 TIMES PER LIFE TIME)	
MAX. OVERCURRENT			1.5 x I_n (NORMAL DUTY) OR 2 x I_n (HEAVY DUTY)	
			(INCLUDING COMBINED EFFECTS OF OVERVOLTAGES, HARMONICS AND CAPACITANCE TOLERANCE)	
INRUSH CURRENT			200 x I_n	
EXPECTED LIFE TIME			> 120000 h (NORMAL DUTY)	
			> 150000 h (HEAVY DUTY)	
DISCHARGE RESISTOR			TO 75 V ≤ 3 min	
ALTITUDE			UP TO 4000 m	
INSULATION LEVEL		kV	4/-	
ROUTINE TESTS				
TERMINAL TO TERMINAL			2.15 x U_n , 2 s	
TERMINAL TO CASE			4000 V, 10 s	
SEALING TEST			N/A	75 °C, 6 h
MECHANICAL PARAMETERS				
TERMINAL PER PHASE / TERMINAL HEIGHT (TH) / MAX. TORQUE / MAX. CURRENT			2 x 25 mm ² / 35 mm / 3 Nm / 60 A for D > 90 mm	
			2 x 16 mm ² / 30 mm / 2 Nm / 35 A for D = 75 mm	
MOUNTING AND GROUNDING / MAX. TORQUE			THREADED M12 BOLT / 10 Nm	
MOUNTING POSITION			VERTICAL WITH TERMINAL POINTING UPWARDS OR HORIZONTAL	VERTICAL WITH TERMINAL POINTING UPWARDS
PROTECTION			IP20	
CLEARANCE DISTANCE			> 16 mm	
CREEPAGE DISTANCE			> 16 mm	
SAFETY DEVICE			OVERPRESSURE DISCONNECTOR (ALL PHASES)	
MATERIAL PARAMETERS				
DIELECTRIC			SELF HEALING METALLIZED POLYPROPYLENE FILM	
FILLING			DRY (FILLED WITH NON PCB POLYURETHANE RESIN)	NON PCB BIODEGRADABLE VEGETABLE OIL
CASE			ALUMINIUM	
REFERENCE STANDARD				
			UL-CSA APPROVED (FILE NO. 163120)	



UL-CSA APPROVED (FILE NO. 163120)

PFC CAPACITORS FOR LOW VOLTAGE (THREE-PHASE)

KNK3053, KNK4053 - CYLINDRICAL ALUMINIUM HOUSING



220 ... 800 V, 5 ... 50 kVar

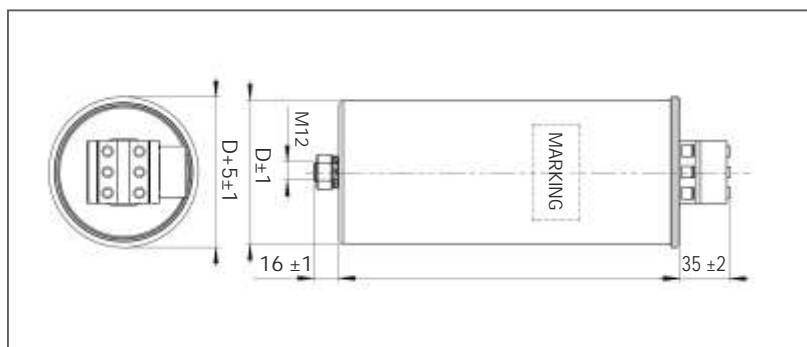

$f_n = 50 \text{ Hz}$ - NORMAL DUTY

C_n (μF)	$U_n = 400 \text{ V}$		$U_n = 380 \text{ V}$		O_n (kVar)	I_n (A)	D (mm)	H (mm)	Weight (kg)		Packing unit (pcs)	Approval
	O_n (kVar)	I_n (A)	O_n (kVar)	I_n (A)					KNK3053	KNK4053		
3 x 33.2	5	7.2	4.5	6.8			75	165	0.9	0.8	16	●
3 x 49.7	7.5	10.8	6.7	10.2			75	210	1.1	1.0	16	●
3 x 66.3	10	14.4	9	13.7			75	210	1.1	1.0	16	●
3 x 82.9	12.5	18	11.3	17.2			75	245	1.4	1.2	16	●
3 x 99.5	15	21.7	13.5	20.5			90	210	1.5	1.3	16	●
3 x 132.5	20	28.9	18	27.3			90	245	1.8	1.5	16	●
3 x 165.8	25	36.1	22.5	34.2			90	285	2.1	1.8	16	●
3 x 198.9	30	43.1	27	41			116	245	3.0	2.6	9	●
3 x 265.3	40	57.7	36.1	54.8			116	285	3.6	3.2	9	●
3 x 331.6	50	72.2	45.1	68.6			136	245	4	3.6	2	●
	$U_n = 440 \text{ V}$		$U_n = 400 \text{ V}$		$U_n = 380 \text{ V}$				KNK3053	KNK4053		
3 x 27.4	5	6.6	4.1	5.9	3.7	5.6	75	165	0.9	0.8	16	●
3 x 41.1	7.5	9.8	6.2	8.9	5.6	8.5	75	210	1.1	1.0	16	●
3 x 54.8	10	13.1	8.3	12	7.4	11.2	75	245	1.4	1.2	16	●
3 x 68.5	12.5	16.4	10.4	15	9.3	14.1	90	210	1.5	1.3	16	●
3 x 82.2	15	19.7	12.4	17.9	11.2	17	90	245	1.8	1.5	16	●
3 x 109.6	20	26.2	16.6	24	15	22.8	90	285	2.1	1.8	16	●
3 x 137	25	32.8	20.7	29.9	18.6	28.3	116	210	2.5	2.2	9	●
3 x 164.4	30	39.4	24.8	35.8	22.4	34	116	245	3.0	2.6	9	●
3 x 219.2	40	52.5	33.1	47.6	29.8	45.3	116	285	3.6	3.2	9	●
3 x 274	50	65.6	41.3	59.6	37.3	56.7	136	245	4	3.6	2	●
	$U_n = 480 \text{ V}$		$U_n = 440 \text{ V}$		$U_n = 400 \text{ V}$				KNK3053	KNK4053		
3 x 23	5	6	4.2	5.5	3.5	5.1	75	165	0.9	0.8	16	●
3 x 34.5	7.5	9	6.3	8.3	5.2	7.5	75	210	1.1	1.0	16	●
3 x 46.1	10	12	8.4	11	7	10.1	75	210	1.1	1.0	16	●
3 x 57.6	12.5	15	10.5	13.8	8.6	12.4	75	245	1.4	1.2	16	●
3 x 69.1	15	18	12.7	16.7	10.5	15.2	90	210	1.5	1.3	16	●
3 x 92.1	20	24.1	16.9	22.2	13.9	20.1	90	245	1.8	1.5	16	●
3 x 115.1	25	30.1	21	27.6	17.4	25.1	90	285	2.1	1.8	16	●
3 x 138.2	30	36.1	25.2	33.1	20.8	30	116	210	2.5	2.2	9	●
3 x 184.2	40	48.1	33.5	44	27.7	40.1	116	285	3.6	3.2	9	●
3 x 230.3	50	60.1	42	55.1	34.7	50.1	136	245	4	3.6	2	●
	$U_n = 525 \text{ V}$		$U_n = 480 \text{ V}$		$U_n = 440 \text{ V}$				KNK3053	KNK4053		
3 x 19.3	5	5.5	4.4	5.1	3.5	4.6	75	165	0.9	0.8	16	●
3 x 28.9	7.5	8.2	6.2	7.5	5.3	7	75	210	1.1	1.0	16	●
3 x 38.5	10	11	8.4	10	7	9.2	75	245	1.4	1.2	16	●
3 x 48.1	12.5	13.7	10.5	12.6	8.8	11.5	75	245	1.4	1.2	16	●
3 x 57.7	15	16.5	12.5	15	10.5	13.8	90	210	1.5	1.3	16	●
3 x 77	20	22	16.7	20.1	14	18.4	90	285	2.1	1.8	16	●
3 x 96.2	25	27.5	20.9	25.1	17.6	23.1	116	210	2.5	2.2	9	●
3 x 115.5	30	33	25	30.1	21.1	27.7	116	245	3.0	2.6	9	●
3 x 154	40	44	33.4	40.2	28.1	36.9	116	285	3.6	3.2	9	●
3 x 192.5	50	55	41.8	50.3	35.1	46.1	136	245	4	3.6	2	●

PFC CAPACITORS FOR LOW VOLTAGE (THREE-PHASE)

KNK3053, KNK4053 - CYLINDRICAL ALUMINIUM HOUSING

$f_n = 50 \text{ Hz}$ - NORMAL DUTY

C_n (μF)	Q_n (kVar)	I_n (A)	Q_n (kVar)	I_n (A)	Q_n (kVar)	I_n (A)	D (mm)	H (mm)	Weight (kg)		Packing unit (pcs)	Approval  C22.2 No. 198 PROTECTED: 10 000 A-C
									KNK3053	KNK4053		
$U_n = 690 \text{ V}$												
3 x 11.1	5	4.2					75	165	0.9	0.8	16	
3 x 16.7	7.5	6.3					75	210	1.1	1.0	16	
3 x 22.3	10	8.4					75	210	1.1	1.0	16	
3 x 27.9	12.5	10.5					75	245	1.4	1.2	16	
3 x 33.4	15	12.6					90	210	1.5	1.3	16	
3 x 44.6	20	16.7					90	245	1.8	1.5	16	
3 x 55.7	25	20.9					116	210	2.5	2.2	16	
3 x 66.9	30	25.1					116	245	3.0	2.6	9	
3 x 89.1	40	33.5					116	285	3.6	3.2	9	
$U_n = 800 \text{ V}$												
3 x 27.4	5	6.6					75	165	0.9	0.8	16	
3 x 41.1	7.5	9.8					75	210	1.1	1.0	16	
3 x 54.8	10	13.1					75	245	1.4	1.2	16	
3 x 68.5	12.5	16.4					75	245	1.4	1.2	16	
3 x 82.2	15	19.7					90	210	1.5	1.3	16	
3 x 109.6	20	26.2					90	285	2.1	1.8	16	
3 x 137	25	32.8					116	210	2.5	2.2	9	
3 x 164.4	30	39.4					116	245	3.0	2.6	9	
3 x 219.2	40	52.5					116	285	3.6	3.2	9	

$f_n = 50 \text{ Hz}$ - HEAVY DUTY

C_n (μF)	Q_n (kVar)	I_n (A)	Q_n (kVar)	I_n (A)	Q_n (kVar)	I_n (A)	D (mm)	H (mm)	Weight (kg)		Packing unit (pcs)	Approval  C22.2 No. 198 PROTECTED: 10 000 A-C
									KNK3053	KNK4053		
$U_n = 400 \text{ V}$												
3 x 33.2	5	7.2	4.5	6.8			75	165	0.9	0.8	16	●
3 x 49.7	7.5	10.8	6.7	10.2			75	210	1.1	1.0	16	●
3 x 66.3	10	14.4	9	13.7			90	210	1.5	1.3	16	●
3 x 82.9	12.5	18	11.3	17.2			90	245	1.8	1.5	16	●
3 x 99.5	15	21.7	13.5	20.5			90	245	1.8	1.5	16	●
3 x 132.5	20	28.9	18	27.3			116	210	2.5	2.2	16	●
3 x 165.8	25	36.1	22.5	34.2			116	245	3.0	2.6	9	●
3 x 198.9	30	43.1	27	41			116	285	3.6	3.2	9	●
3 x 265.3	40	57.7	36.1	54.8			136	285	4.6	4.1	9	●
3 x 331.6	50	72.2	45.1	68.6			136	310	5	4.5	1	●
$U_n = 440 \text{ V}$												
3 x 27.4	5	6.6	4.1	5.9	3.7	5.6	75	210	1.1	1.0	16	●
3 x 41.1	7.5	9.8	6.2	8.9	5.6	8.5	75	245	1.4	1.2	16	●
3 x 54.8	10	13.1	8.3	12	7.4	11.2	90	210	1.5	1.3	16	●
3 x 68.5	12.5	16.4	10.4	15	9.3	14.1	90	245	1.8	1.5	16	●
3 x 82.2	15	19.7	12.4	17.9	11.2	17	90	285	2.1	1.8	16	●
3 x 109.6	20	26.2	16.6	24	15	22.8	116	245	3.0	2.6	9	●
3 x 137	25	32.8	20.7	29.9	18.6	28.3	116	245	3.0	2.6	9	●
3 x 164.4	30	39.4	24.8	35.8	22.4	34	116	285	3.6	3.2	9	●
3 x 219.2	40	52.5	33.1	47.6	29.8	45.3	136	285	4.6	4.1	1	●
3 x 274	50	65.6	41.3	59.6	37.3	56.7	136	310	5	4.5	1	●
$U_n = 480 \text{ V}$												
3 x 23	5	6	4.2	5.5	3.5	5.1	75	165	0.9	0.8	16	●
3 x 34.5	7.5	9	6.3	8.3	5.2	7.5	75	210	1.1	1.0	16	●
3 x 46.1	10	12	8.4	11	7	10.1	75	245	1.4	1.2	16	●
3 x 57.6	12.5	15	10.5	13.8	8.6	12.4	90	210	1.5	1.3	16	●
3 x 69.1	15	18	12.7	16.7	10.5	15.2	90	245	1.8	1.5	16	●
3 x 92.1	20	24.1	16.9	22.2	13.9	20.1	90	285	2.1	1.8	16	●
3 x 115.1	25	30.1	21	27.6	17.4	25.1	116	245	3.0	2.6	9	●
3 x 138.2	30	36.1	25.2	33.1	20.8	30	116	285	3.6	3.2	9	●
3 x 184.2	40	48.1	33.5	44	27.7	40.1	136	245	4.0	3.6	1	●
3 x 230.3	50	60.1	42	55.1	34.7	50.1	136	285	4.6	4.1	2	●
$U_n = 525 \text{ V}$												
3 x 19.3	5	5.5	4.4	5.1	3.5	4.6	75	165	0.9	0.8	16	●
3 x 28.9	7.5	8.2	6.2	7.5	5.3	7	75	210	1.2	1.1	16	●
3 x 38.5	10	11	8.4	10	7	9.2	90	210	1.5	1.3	16	●
3 x 48.1	12.5	13.7	10.5	12.6	8.8	11.5	90	245	1.8	1.5	16	●
3 x 57.7	15	16.5	12.5	15	10.5	13.8	90	245	2.1	1.8	16	●
3 x 77	20	22	16.7	20.1	14	18.4	116	210	2.5	2.2	9	●
3 x 96.2	25	27.5	20.9	25.1	17.6	23.1	116	245	3.0	2.6	9	●
3 x 115.5	30	33	25	30.1	21.1	27.7	116	285	3.6	3.2	9	●
3 x 154	40	44	33.4	40.2	28.1	36.9	136	245	4.6	4.1	1	●
3 x 192.5	50	55	41.8	50.3	35.1	46.1	136	285	4.6	4.1	2	●

PFC CAPACITORS FOR LOW VOLTAGE (THREE-PHASE)

KNK3053, KNK4053 - CYLINDRICAL ALUMINIUM HOUSING

$f_n = 50 \text{ Hz}$ - HEAVY DUTY

C_n (μF)	Q_n (kVar)	I_n (A)	Q_n (kVar)	I_n (A)	Q_n (kVar)	I_n (A)	D (mm)	H (mm)	Weight (kg)		Packing unit (pcs)	Approval  C22 No. 199 PROTECTED: 10 000 A-C
									KNK3053	KNK4053		
$U_n = 690 \text{ V}$												
3 x 11.1	5	4.2					75	165	0.9	0.8	16	
3 x 16.7	7.5	6.3					90	165	1.2	1.1	16	
3 x 22.3	10	8.4					90	210	1.5	1.3	16	
3 x 27.9	12.5	10.5					90	245	1.8	1.5	16	
3 x 33.4	15	12.6					90	285	2.1	1.8	16	
3 x 44.6	20	16.7					116	210	2.5	2.2	9	
3 x 55.7	25	20.9					116	245	3.0	2.6	9	
3 x 66.9	30	25.1					116	285	3.6	3.2	9	
3 x 89.1	40	33.5					136	285	4.6	4.1	1	
$U_n = 800 \text{ V}$												
3 x 8.3	5	3.6					75	210	1.1	1.0	16	
3 x 12.4	7.5	5.4					75	245	1.4	1.2	16	
3 x 16.6	10	7.2					90	210	1.5	1.3	16	
3 x 20.7	12.5	9					90	245	1.8	1.5	16	
3 x 24.9	15	10.8					90	285	2.1	1.8	16	
3 x 33.2	20	14.4					116	210	2.5	2.2	9	
3 x 41.5	25	18					116	245	3.0	2.6	9	
3 x 49.7	30	21.7					116	285	3.6	3.2	9	
3 x 66.3	40	28.9					136	285	4.6	4.1	1	

$f_n = 60 \text{ Hz}$ - NORMAL DUTY

C_n (μF)	Q_n (kVar)	I_n (A)	Q_n (kVar)	I_n (A)	Q_n (kVar)	I_n (A)	D (mm)	H (mm)	Weight (kg)		Packing unit (pcs)	Approval  C22 No. 199 PROTECTED: 10 000 A-C
									KNK3053	KNK4053		
$U_n = 400 \text{ V}$												
3 x 27.6	5	7.2	4.5	6.8			75	165	0.9	0.8	16	●
3 x 41.5	7.5	10.8	6.7	10.2			75	165	0.9	0.8	16	●
3 x 55.3	10	14.4	9	13.7			75	210	1.1	1.0	16	●
3 x 69.1	12.5	18	11.3	17.2			75	245	1.4	1.2	16	●
3 x 82.9	15	21.7	13.5	20.5			75	245	1.4	1.2	16	●
3 x 110.5	20	28.9	18	27.3			90	245	1.8	1.5	16	●
3 x 138.2	25	36.1	22.6	34.3			90	285	2.1	1.8	16	●
3 x 165.8	30	43.1	27	41			116	210	2.5	2.2	9	●
3 x 221.1	40	57.7	36.1	54.8			116	245	3.0	2.6	9	●
3 x 276.3	50	72.2	45.1	68.6			116	285	3.6	3.2	4	●
$U_n = 440 \text{ V}$												
3 x 22.8	5	6.6	4.1	5.9	3.7	5.6	75	165	0.9	0.8	16	●
3 x 34.3	7.5	9.8	6.2	8.9	5.6	8.5	75	210	1.1	1.0	16	●
3 x 45.7	10	13.1	8.3	12	7.5	11.4	75	210	1.1	1.0	16	●
3 x 57.1	12.5	16.4	10.4	14.9	9.3	14.1	75	245	1.4	1.2	16	●
3 x 68.5	15	19.7	12.4	17.9	11.2	17	90	210	1.5	1.3	16	●
3 x 91.3	20	26.2	16.6	23.8	14.9	22.6	90	245	1.8	1.5	16	●
3 x 114.2	25	32.8	20.7	29.9	18.7	28.4	90	285	2.1	1.8	16	●
3 x 137	30	39.4	24.8	35.8	22.4	34	116	210	2.5	2.2	9	●
3 x 182.7	40	52.5	33.1	47.6	29.8	45.3	116	285	3.6	3.2	9	●
3 x 228.4	50	65.6	41.3	59.6	37.3	56.7	116	285	3.6	3.2	4	●
$U_n = 480 \text{ V}$												
3 x 19.2	5	6	4.2	5.5	3.5	5.1	75	165	0.9	0.8	16	●
3 x 28.8	7.5	9	6.3	8.3	5.2	7.5	75	165	0.9	0.8	16	●
3 x 38.4	10	12	8.4	11	7	10.1	75	210	1.1	1.0	16	●
3 x 50	12.5	15	11	14.4	9	13	75	245	1.4	1.2	16	●
3 x 57.6	15	18	12.8	16.8	10.4	15	75	245	1.4	1.2	16	●
3 x 76.8	20	24.1	16.8	22	13.9	20.1	75	210	1.5	1.3	16	●
3 x 95.9	25	30.1	21	27.6	17.4	25.1	90	245	1.8	1.5	16	●
3 x 115.1	30	36.1	25.2	33.1	20.8	30	90	285	2.1	1.8	16	●
3 x 153.5	40	48.1	33.6	44.1	27.8	40.1	90	245	3.0	2.6	9	●
3 x 191.9	50	60.1	42	55.1	34.7	50.1	116	245	3.0	2.6	4	●
$U_n = 525 \text{ V}$												
3 x 16	5	6.5	4.4	5.1	3.5	4.6	75	165	0.9	0.8	16	●
3 x 24.1	7.5	8.2	6.3	7.6	5.3	7	75	165	0.9	0.8	16	●
3 x 32.1	10	11	8.4	10.1	7	9.2	75	210	1.1	1.0	16	●
3 x 40.1	12.5	13.7	10.5	12.6	8.8	11.5	75	245	1.4	1.2	16	●
3 x 48.1	15	16.5	12.5	15	10.5	13.8	75	245	1.4	1.2	16	●
3 x 64.2	20	22	16.7	20.1	14.1	18.5	75	245	1.8	1.5	16	●
3 x 80.2	25	27.5	21	25.3	17.5	23	90	285	2.1	1.8	16	●
3 x 96.2	30	33	25.1	30.2	21	27.6	90	210	2.5	2.2	9	●
3 x 128.3	40	44	33.5	40.3	28.1	36.9	116	245	3.0	2.6	9	●
3 x 160.4	50	55	41.8	50.3	35.1	46.1	116	285	3.6	3.2	4	●

PFC CAPACITORS FOR LOW VOLTAGE (THREE-PHASE)

KNK3053, KNK4053 - CYLINDRICAL ALUMINIUM HOUSING

$f_n = 60 \text{ Hz}$ - NORMAL DUTY

C_n (μF)	Q_n (kVar)	I_n (A)	Q_n (kVar)	I_n (A)	Q_n (kVar)	I_n (A)	D (mm)	H (mm)	Weight (kg)		Packing unit (pcs)	Approval  C22.2 No. 198 PROTECTED: 10 000 A-C
									KNK3053	KNK4053		
$U_n = 690 \text{ V}$												
3 x 9.3	5	4.2					75	165	0.9	0.8	16	
3 x 13.9	7.5	6.3					75	165	0.9	0.8	16	
3 x 18.6	10	8.4					75	210	1.1	1.0	16	
3 x 23.2	12.5	10.5					75	245	1.4	1.2	16	
3 x 27.9	15	12.6					75	245	1.4	1.2	16	
3 x 37.1	20	16.7					90	245	1.8	1.5	16	
3 x 46.4	25	20.9					90	245	1.8	1.5	16	
3 x 55.7	30	25.1					90	285	2.1	1.8	16	
3 x 74.3	40	33.5					116	245	3.0	2.6	9	
$U_n = 800 \text{ V}$												
3 x 6.9	5	3.6					75	165	0.9	0.8	16	
3 x 10.4	7.5	5.4					75	165	0.9	0.8	16	
3 x 13.8	10	7.2					75	210	1.1	1.0	16	
3 x 17.3	12.5	9					75	245	1.4	1.2	16	
3 x 20.7	15	10.8					90	210	1.5	1.3	16	
3 x 27.6	20	14.4					90	245	1.8	1.5	16	
3 x 34.5	25	18					90	285	2.1	1.8	16	
3 x 41.6	30	21.7					116	210	2.5	2.2	9	
3 x 55.3	40	28.9					116	245	3.0	2.6	9	

$f_n = 60 \text{ Hz}$ - HEAVY DUTY

C_n (μF)	Q_n (kVar)	I_n (A)	Q_n (kVar)	I_n (A)	Q_n (kVar)	I_n (A)	D (mm)	H (mm)	Weight (kg)		Packing unit (pcs)	Approval  C22.2 No. 198 PROTECTED: 10 000 A-C
									KNK3053	KNK4053		
$U_n = 400 \text{ V}$												
3 x 27.6	5	7.2	4.5	6.8			75	165	0.9	0.8	16	●
3 x 41.5	7.5	10.8	6.7	10.2			75	210	1.1	1.0	16	●
3 x 55.3	10	14.4	9	13.7			75	245	1.4	1.2	16	●
3 x 69.1	12.5	18	11.3	17.2			90	210	1.5	1.3	16	●
3 x 82.9	15	21.7	13.5	20.5			90	245	1.8	1.5	16	●
3 x 110.5	20	28.9	18	27.3			90	285	2.1	1.8	16	●
3 x 138.2	25	36.1	22.6	34.3			116	210	2.5	2.2	16	●
3 x 165.8	30	43.1	27	41			116	245	3.0	2.6	9	●
3 x 221.1	40	57.7	36.1	54.8			136	245	4.0	3.6	9	●
3 x 276.3	50	72.2	45.1	68.6			136	285	4.6	4.1	2	●
$U_n = 440 \text{ V}$												
3 x 22.8	5	6.6	4.1	5.9	3.7	5.6	75	165	0.9	0.8	16	●
3 x 34.3	7.5	9.8	6.2	8.9	5.6	8.5	75	210	1.1	1.0	16	●
3 x 45.7	10	13.1	8.3	12	7.5	11.4	75	245	1.4	1.2	16	●
3 x 57.1	12.5	16.4	10.3	14.9	9.3	14.1	90	210	1.5	1.3	16	●
3 x 68.5	15	19.7	12.4	17.9	11.2	17	90	245	1.8	1.5	16	●
3 x 91.3	20	26.2	16.5	23.8	14.9	22.6	90	285	2.1	1.8	16	●
3 x 114.2	25	32.8	20.7	29.9	18.7	28.4	116	245	3.0	2.6	9	●
3 x 137	30	39.4	24.8	35.8	22.4	34	116	245	3.0	2.6	9	●
3 x 182.7	40	52.5	33.1	47.6	29.8	45.3	136	245	4.0	3.6	1	●
3 x 228.4	50	65.6	41.3	59.6	37.3	56.7	136	285	4.6	4.1	2	●
$U_n = 480 \text{ V}$												
3 x 19.2	5	6	4.2	5.5	3.5	5.1	75	165	0.9	0.8	16	●
3 x 28.8	7.5	9	6.3	8.3	5.2	7.5	75	210	1.1	1.0	16	●
3 x 38.4	10	12	8.4	11	7	10.1	75	245	1.4	1.2	16	●
3 x 50	12.5	15	11	14.4	9	13	90	210	1.5	1.3	16	●
3 x 57.6	15	18	12.8	16.8	10.4	15	90	210	1.5	1.3	16	●
3 x 76.8	20	24.1	16.8	22	13.9	20.1	90	245	1.8	1.5	16	●
3 x 95.9	25	30.1	21	27.6	17.4	25.1	116	210	2.5	2.2	9	●
3 x 115.1	30	36.1	25.2	33.1	20.8	30	116	245	3.0	2.6	9	●
3 x 153.5	40	48.1	33.6	44.1	27.8	40.1	116	285	3.6	3.2	9	●
3 x 191.9	50	60.1	42	55.1	34.7	50.1	136	245	4.0	3.6	2	●
$U_n = 525 \text{ V}$												
3 x 16	5	6.5	4.2	5.1	3.5	4.6	75	165	0.9	0.8	16	●
3 x 24.1	7.5	8.2	6.3	7.6	5.3	7	75	210	1.1	1.0	16	●
3 x 32.1	10	11	8.4	10.1	7	9.2	75	245	1.4	1.2	16	●
3 x 40.1	12.5	13.7	10.5	12.6	8.8	11.5	90	210	1.5	1.3	16	●
3 x 48.1	15	16.5	12.5	15	10.5	13.8	90	245	1.8	1.5	16	●
3 x 64.2	20	22	16.7	20.1	14.1	18.5	90	285	2.1	1.8	16	●
3 x 80.2	25	27.5	21	25.3	17.5	23	116	210	2.5	2.2	9	●
3 x 96.2	30	33	25.1	30.2	21	27.6	116	245	3.0	2.6	9	●
3 x 128.3	40	44	33.5	40.3	28.1	36.9	116	285	3.6	3.7	9	●
3 x 160.4	50	55	41.8	50.3	35.1	46.1	136	285	4.6	4.1	2	●

PFC CAPACITORS FOR LOW VOLTAGE (THREE-PHASE)

KNK3053, KNK4053 - CYLINDRICAL ALUMINIUM HOUSING

$f_n = 60 \text{ Hz}$ - HEAVY DUTY

C_n (μF)	Q_n (kVar)	I_n (A)	Q_n (kVar)	I_n (A)	Q_n (kVar)	I_n (A)	D (mm)	H (mm)	Weight (kg)		Packing unit (pcs)	Approval  C22.2 No. 198 PROTECTED TO 600 A/C
									KNK3053	KNK4053		
$U_n = 690 \text{ V}$												
3 x 9.3	5	4.2					75	165	0.9	0.8	16	
3 x 13.9	7.5	6.3					75	210	1.1	1.0	16	
3 x 18.6	10	8.4					75	245	1.4	1.2	16	
3 x 23.2	12.5	10.5					90	210	1.5	1.3	16	
3 x 27.9	15	12.6					90	245	1.8	1.5	16	
3 x 37.1	20	16.7					90	285	2.1	1.8	16	
3 x 46.4	25	20.9					116	245	3.0	2.6	9	
3 x 55.7	30	25.1					116	245	3.0	2.6	9	
3 x 74.3	40	33.5					116	285	4.0	3.6	1	
$U_n = 800 \text{ V}$												
3 x 6.9	5	3.6					75	165	0.9	0.8	16	
3 x 10.4	7.5	5.4					75	210	1.1	1.0	16	
3 x 13.8	10	7.2					75	245	1.4	1.2	16	
3 x 17.3	12.5	9					90	210	1.5	1.3	16	
3 x 20.7	15	10.8					90	245	1.8	1.5	16	
3 x 27.6	20	14.4					90	285	2.1	1.8	16	
3 x 34.5	25	18					116	245	3.0	2.6	9	
3 x 41.6	30	21.7					116	245	3.0	2.6	9	
3 x 55.3	40	28.9					136	245	4.0	3.6	1	

PFC CAPACITORS FOR LOW VOLTAGE (SINGLE- AND THREE-PHASE)

KNK9103, KNK9143, KNK9101, KNK9141 - PRISMATIC

TECHNICAL DATA				
TYPE	SYMBOL	UNIT	KNK9103, KNK9143	KNK9101, KNK9141
STANDARDS			IEC/EN 60831-1/2	
CONNECTION			DELTA (THREE-PHASE)	SINGLE PHASE
RATED REACTIVE POWER	Q_n	kVar	UP TO 60	
RATED VOLTAGE	U_n	V	220 - 525	
RATED FREQUENCY	f_n	Hz	50 OR 60	
CAPACITANCE TOLERANCE			-5/10 % (OTHER ON REQUEST)	
DIELECTRIC LOSSES		W/kVar	≤ 0.2	
TOTAL LOSSES		W/kVar	≤ 0.5	
TEMPERATURE CATEGORY			-25/D	
MAX. HUMIDITY			95 %	
COOLING			FORCED VENTILATION OR NATURAL AIR COOLED	
MAX. OVERVOLTAGE			1.1 x U_n (8 h/DAY)	
			1.15 x U_n (30 min/DAY)	
			1.2 x U_n (5 min - 200 TIMES PER LIFE TIME)	
			1.3 x U_n (1 min - 200 TIMES PER LIFE TIME)	
MAX. OVERCURRENT			1.5 x I_n (INCLUDING COMBINED EFFECTS OF OVERVOLTAGES, HARMONICS AND CAPACITANCE TOLERANCE)	
INRUSH CURRENT			200 x I_n	
EXPECTED LIFE TIME			> 100000 h (NORMAL DUTY)	
			> 120000 h (HEAVY DUTY)	
DISCHARGE RESISTOR			TO 75 V ≤ 3 min	
ALTITUDE			UP TO 2000 m	
INSULATION LEVEL		kV	3.6/-	
ROUTINE TESTS				
TERMINAL TO TERMINAL			2.15 x U_n , 2 s	
TERMINAL TO CASE			3600 V, 10 s	
SEALING TEST			75 °C, 6 h	
MECHANICAL PARAMETERS				
TERMINAL PER PHASE / MAX. TORQUE / MAX. CURRENT			M8 / 5 Nm / 50 A M12 / 10 Nm / 90 A	
MOUNTING AND GROUNDING / MAX. TORQUE			THREADED M8 BOLT / 5 Nm	
MOUNTING POSITION			VERTICAL WITH TERMINAL POINTING UPWARDS	
PROTECTION			IP00 - KNK9103, KNK9143	
			IP55 - KNK9143, KNK9141	
CLEARANCE DISTANCE			> 40 mm	
CREEPAGE DISTANCE			> 20 mm	
SAFETY DEVICE			OVERPRESSURE DISCONNECTOR	
MATERIAL PARAMETERS				
DIELECTRIC			SELF HEALING METALLIZED POLYPROPYLENE FILM	
FILLING			NON PCB BIODEGRADABLE VEGETABLE OIL	
CASE			PAINTED METAL HOUSING RAL7032	

PFC CAPACITORS FOR LOW VOLTAGE (THREE-PHASE)

KNK9103, KNK9143 - PRISMATIC

230 ... 525 V, 5 ... 60 kVar



THE CAP FOR KNK9103 (TYPE KNK9153)

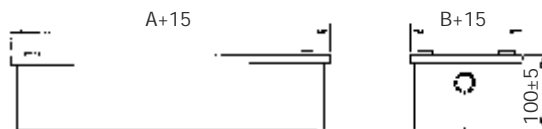

KNK9103

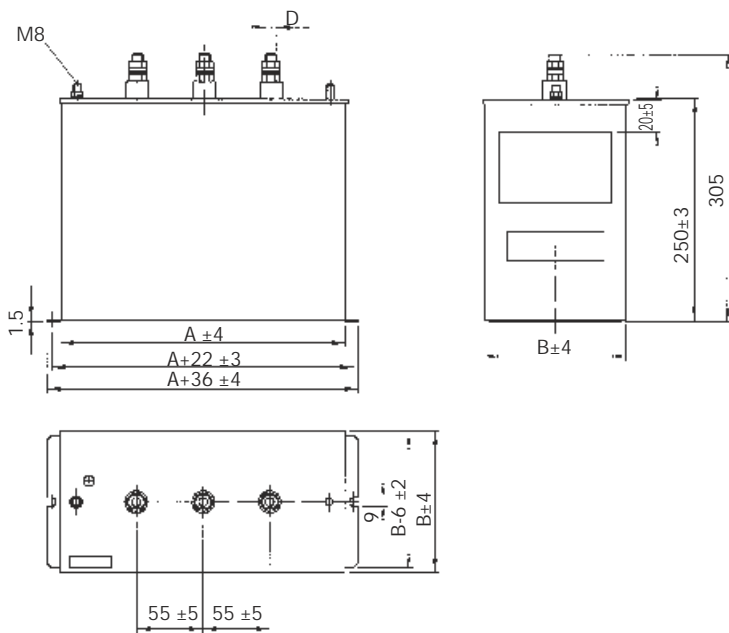

KNK9143

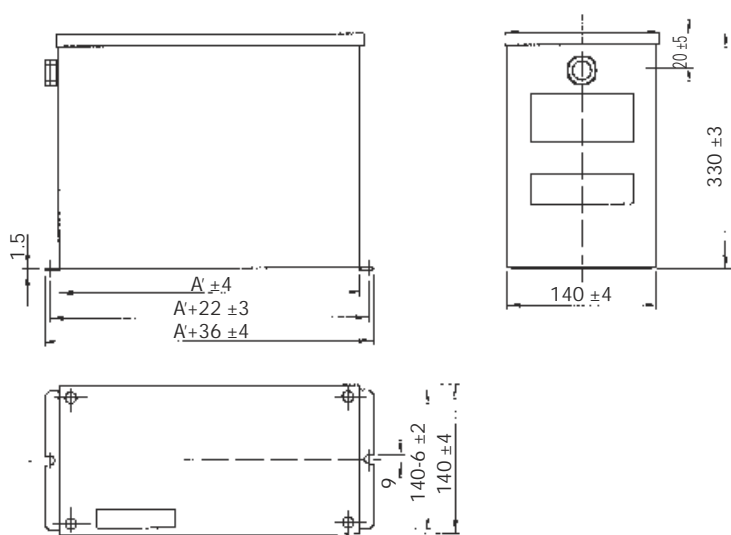

PFC CAPACITORS FOR LOW VOLTAGE (THREE-PHASE)

KNK9103, KNK9143 - PRISMATIC

$f_n = 50 \text{ Hz}$

U_n (V)	Q_n (kVar)	C_n (μF)	I_n (A)	A (mm)	A' (mm)	B (mm)	D	Weight (kg) KNK9103	Weight (kg) KNK9143
230	5	3 x 100.3	12.5	190	190	70	M8	3.65	6.40
230	10	3 x 200.7	25.1	380	190	70	M8	5.65	7.30
230	12.5	3 x 250.7	32.1	380	190	70	M8	5.95	7.80
230	15	3 x 301	37.6	380	380	140	M12	8.30	12.40
230	20	3 x 401.2	50.2	380	380	140	M12	9.65	13.20
230	25	3 x 501.5	62.7	380	380	140	M12	10.25	13.80
400	5	3 x 33.2	7.2	190	190	70	M8	2.95	6.00
400	7.5	3 x 49.7	10.8	190	190	70	M8	3.05	6.10
400	10	3 x 66.3	14.4	190	190	70	M8	3.25	6.25
400	12.5	3 x 82.9	18	190	190	70	M8	3.30	6.30
400	15	3 x 99.5	21.7	190	190	70	M8	3.65	6.45
400	20	3 x 132.6	28.9	380	190	70	M8	5.65	7.30
400	25	3 x 165.8	36.1	380	190	70	M8	5.95	7.80
400	30	3 x 198.9	43.3	380	190	70	M8	6.25	8.10
400	40	3 x 265.3	57.7	380	380	140	M12	8.30	12.20
400	50	3 x 331.6	72.2	380	380	140	M12	9.65	13.20
400	60	3 x 397.9	86.6	380	380	140	M12	10.25	13.80
440	5	3 x 27.4	6.5	190	190	70	M8	2.95	6.00
440	7.5	3 x 41.1	9.8	190	190	70	M8	3.05	6.10
440	10	3 x 54.8	13.1	190	190	70	M8	3.25	6.25
440	12.5	3 x 68.5	16.4	190	190	70	M8	3.30	6.30
440	15	3 x 82.2	19.7	190	190	70	M8	3.65	6.45
440	20	3 x 109.6	26.3	380	190	70	M8	5.65	7.30
440	25	3 x 137	32.8	380	190	70	M8	5.95	7.80
440	30	3 x 164.4	39.4	380	190	70	M8	6.25	8.10
440	40	3 x 219.2	52.6	380	380	140	M12	8.30	12.20
440	50	3 x 272	65.6	380	380	140	M12	9.65	13.20
440	60	3 x 328.8	78.8	380	380	140	M12	10.25	13.80
480	5	3 x 23	6	190	190	70	M8	2.95	6.10
480	7.5	3 x 34.5	9	190	190	70	M8	3.05	6.10
480	10	3 x 46	12	190	190	70	M8	3.25	6.30
480	12.5	3 x 57.6	15	190	190	70	M8	3.30	6.40
480	15	3 x 69.1	18	190	190	70	M8	3.65	7.30
480	20	3 x 92.1	24.1	380	190	70	M8	5.65	7.30
480	25	3 x 115.1	30.1	380	190	70	M8	5.95	7.80
480	30	3 x 138.2	36.1	380	190	70	M8	6.25	8.10
480	40	3 x 184.2	48.1	380	380	140	M12	8.30	12.20
480	50	3 x 230.3	60.1	380	380	140	M12	9.65	13.20
480	60	3 x 276.3	72.2	380	380	140	M12	10.25	13.80
525	7.5	3 x 28.9	8.2	190	190	70	M8	3.05	6.25
525	10	3 x 39	11	190	190	70	M8	3.25	6.30
525	12.5	3 x 48.1	13.8	190	190	70	M8	3.30	6.45
525	15	3 x 57.7	16.5	190	190	70	M8	3.65	7.30
525	20	3 x 77	22	380	190	70	M8	5.65	7.80
525	25	3 x 92.2	27.5	380	190	70	M8	5.95	8.10
525	30	3 x 115.5	33	380	190	70	M8	6.25	12.20
525	40	3 x 154	44	380	380	140	M12	8.30	13.20
525	50	3 x 192.5	55	380	380	140	M12	9.65	13.80

PFC CAPACITORS FOR LOW VOLTAGE (THREE-PHASE)

KNK9103, KNK9143 - PRISMATIC

$f_n = 60 \text{ Hz}$

U_n (V)	Q_n (kVar)	C_n (μF)	I_n (A)	A (mm)	A' (mm)	B (mm)	D	Weight (kg) KNK9103	Weight (kg) KNK9143
220	5	3 x 91.3	13.13	190	190	70	M8	3.65	6.40
220	10	3 x 182.6	26.27	380	190	70	M8	5.95	7.30
220	15	3 x 273.9	39.41	380	190	70	M8	6.25	7.75
220	20	3 x 365.2	52.54	380	380	140	M12	8.30	12.10
220	25	3 x 456.5	65.68	380	380	140	M12	9.65	13.10
220	30	3 x 547.8	78.82	380	380	140	M12	10.25	13.70
420	5	3 x 25	6.88	190	190	70	M8	2.95	6.10
420	10	3 x 50.1	13.7	190	190	70	M8	3.25	6.20
420	15	3 x 75.2	20.64	190	190	70	M8	3.65	6.40
420	20	3 x 100.2	27.5	380	190	70	M8	5.65	7.25
420	25	3 x 125.3	34.4	380	190	70	M8	5.95	7.70
420	30	3 x 150.4	41.28	380	190	70	M8	6.25	8.00
420	50	3 x 250.6	68.8	380	380	140	M12	9.65	13.10
420	60	3 x 300.8	82.57	380	380	140	M12	10.25	13.70
440	5	3 x 22.8	6.5	190	190	70	M8	2.95	6.10
440	10	3 x 45.7	13.1	190	190	70	M8	3.25	6.20
440	15	3 x 68.5	19.6	190	190	70	M8	3.65	6.40
440	20	3 x 91.3	26	380	190	70	M8	5.65	7.25
440	25	3 x 114.2	32.8	380	190	70	M8	5.95	7.70
440	30	3 x 137	39.4	380	190	70	M8	6.25	8.00
440	50	3 x 228.4	65.6	380	380	140	M12	9.65	13.10
440	60	3 x 274	78.7	380	380	140	M12	10.25	13.70
480	5	3 x 19.2	6	190	190	70	M8	2.95	6.10
480	10	3 x 38.4	12	190	190	70	M8	3.25	6.20
480	15	3 x 57.6	18	190	190	70	M8	3.65	6.40
480	20	3 x 76.8	24.1	380	190	70	M8	5.65	7.25
480	25	3 x 99	30.1	380	190	70	M8	5.95	7.70
480	30	3 x 115.1	36.1	380	190	70	M8	6.25	8.00
480	40	3 x 153.5	48.1	380	380	140	M12	8.30	13.20
480	50	3 x 192	60.1	380	380	140	M12	9.65	13.50
480	60	3 x 230.3	72.2	380	380	140	M12	10.25	13.80

PFC CAPACITORS FOR LOW VOLTAGE (SINGLE-PHASE)

KNK9101, KNK9141 - PRISMATIC

230 ... 525 V, 5 ... 60 kVar

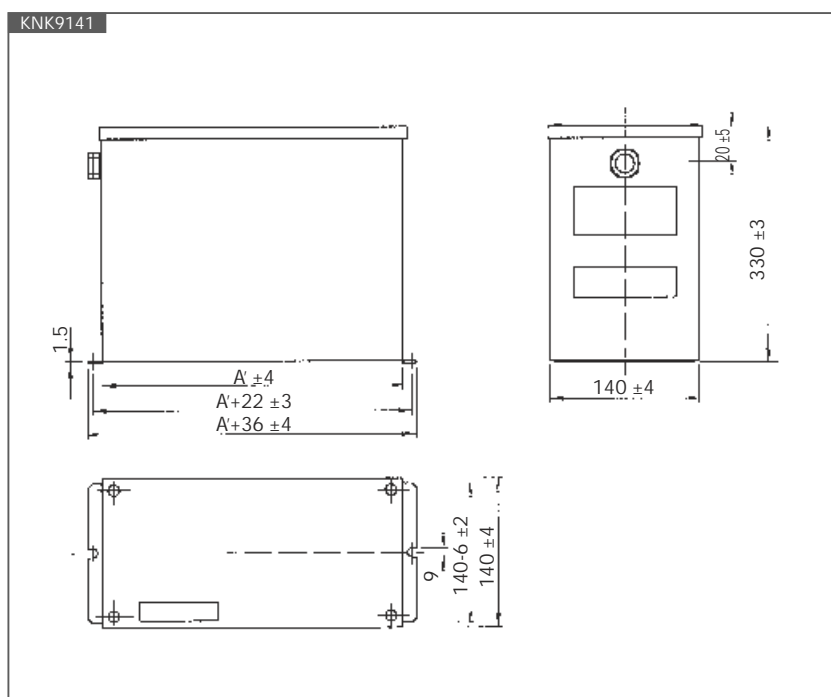
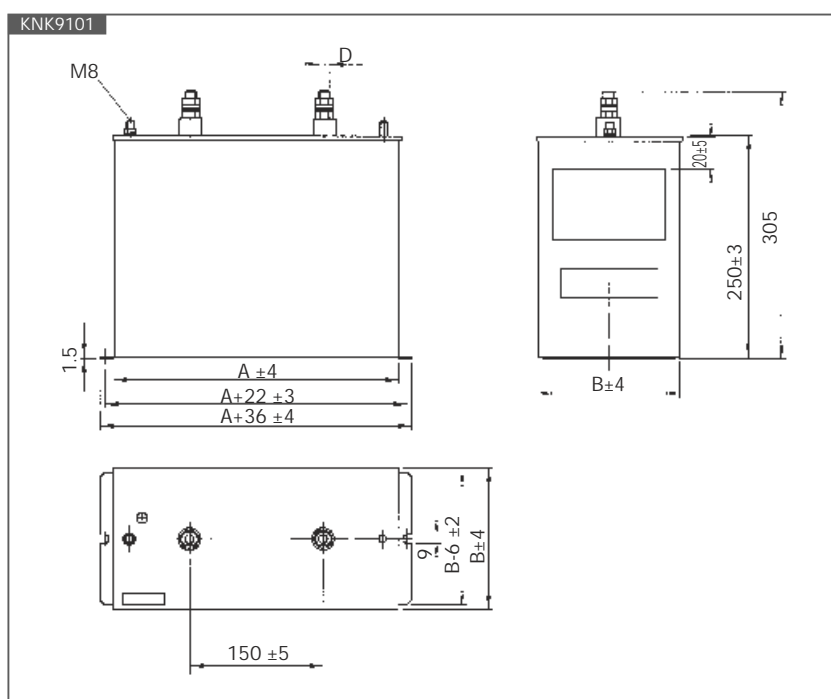
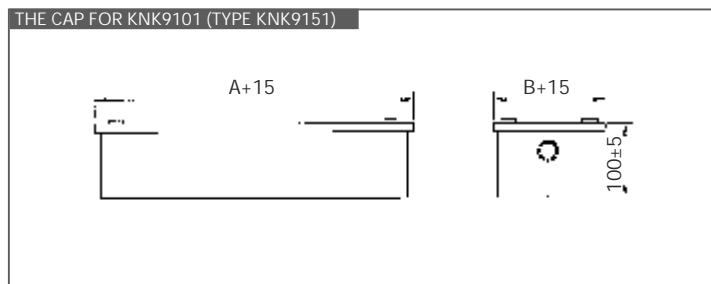

PFC CAPACITORS FOR LOW VOLTAGE (SINGLE-PHASE)

KNK9101, KNK9141 - PRISMATIC

$f_n = 50 \text{ Hz}$

U_n (V)	Q_n (kVar)	C_n (μF)	I_n (A)	A (mm)	A' (mm)	B (mm)	D	Weight (kg) KNK9101	Weight (kg) KNK9141
230	5	300.9	21.7	190	190	70	M8	3.60	6.40
230	7.5	450.6	32.6	380	190	70	M8	5.30	7.25
230	10	602.1	43.4	380	190	70	M8	5.60	7.70
230	12.5	725.1	54.3	380	190	70	M8	5.90	8.00
230	15	903	65.2	380	380	140	M12	8.25	12.10
230	20	1203.6	86.9	380	380	140	M12	9.60	13.10
230	25	1504.4	108.6	380	380	140	M12	10.20	13.70
400	5	99.5	12.5	190	190	70	M8	2.90	5.90
400	7.5	149.1	18.7	190	190	70	M8	3.00	6.00
400	10	198.8	25	190	190	70	M8	3.20	6.10
400	12.5	248.5	31.2	190	190	70	M8	3.25	6.20
400	15	298.2	37.5	190	190	70	M8	3.60	6.40
400	20	397.6	50	380	190	70	M8	5.60	7.25
400	25	497	62.5	380	190	70	M8	5.90	7.70
400	30	596.4	75	380	190	70	M8	6.25	8.00
400	40	795.2	100	380	380	140	M12	8.25	12.10
400	50	994	125	380	380	140	M12	9.60	13.10
440	5	82.2	11.4	190	190	70	M8	2.90	5.30
440	7.5	123.3	17.1	190	190	70	M8	3.00	6.00
440	10	164.4	22.7	190	190	70	M8	3.20	6.10
440	12.5	205.5	28.4	190	190	70	M8	3.25	6.20
440	15	246.6	34.1	190	190	70	M8	3.60	6.40
440	20	328.8	45.5	380	190	70	M8	5.00	6.00
440	25	411	56.8	380	190	70	M8	5.90	7.70
440	30	493.2	68.2	380	190	70	M8	6.25	8.00
440	40	657.7	90.9	380	380	140	M12	8.25	12.10
440	50	822.1	113.6	380	380	140	M12	9.60	13.10
440	60	986.5	136.4	380	380	140	M12	10.20	13.70
480	5	69.1	10.4	190	190	70	M8	2.90	5.30
480	7.5	103.6	15.6	190	190	70	M8	3.00	6.00
480	10	138.1	20.8	190	190	70	M8	3.20	6.10
480	12.5	172.7	26	190	190	70	M8	3.25	6.20
480	15	207.2	31.2	190	190	70	M8	3.60	6.40
480	20	276.3	41.6	380	190	70	M8	5.00	6.00
480	25	354.4	52.1	380	190	70	M8	5.90	7.70
480	30	414.5	62.5	380	190	70	M8	6.25	8.00
480	40	552.6	83.3	380	190	140	M12	8.25	12.10
480	50	690.8	104.1	380	190	140	M12	9.60	13.10
480	60	830	125	380	380	140	M12	10.20	13.70
525	5	57.7	9.5	190	190	70	M8	2.90	5.30
525	7.5	86.6	14.3	190	190	70	M8	3.00	6.00
525	10	115.5	19	190	190	70	M8	3.20	6.10
525	12.5	144.4	23	190	190	70	M8	3.25	6.20
525	15	173.2	28.6	190	190	70	M8	3.60	6.40
525	20	231	38.1	380	190	70	M8	5.00	6.00
525	25	288.7	47.6	380	190	70	M8	5.90	7.70
525	30	346.5	57.5	380	190	70	M8	6.25	8.00
525	40	462	72.2	380	190	140	M12	8.25	12.10
525	50	577.4	95.2	380	380	140	M12	9.60	13.10
525	50	692.9	114.3	380	380	140	M12	10.20	13.70

HIGH VOLTAGE POWER CAPACITORS

KLV



SINGLE-PHASE CAPACITORS



THREE-PHASE CAPACITORS



SINGLE-PHASE WITH TWO OUTPUTS - TWIN CAPACITORS

GENERAL

ADVANCED TECHNOLOGY OF KLV CAPACITORS IS BASED ON CONSTRUCTION OF ALL-FILM CAPACITOR SECTIONS, FOLDING FOIL EDGE DESIGN, IMPROVED ELECTRICAL AND MECHANICAL CONNECTIONS BETWEEN SECTIONS AND IMPREGNATION WITH ENVIRONMENTALLY COMPATIBLE INSULATING OIL. KLV CAPACITORS HAVE VERY LOW DIELECTRIC LOSSES AND ARE DESIGNED FOR LONG SERVICE LIFE.

- KLV 3xxx - INTERNALLY FUSED CAPACITORS. EACH CAPACITOR ELEMENT HAS A SEPARATE INTERNAL FUSE.
- KLV1xxx - CAPACITORS WITHOUT INTERNAL FUSES
- KLVxxx4 - SINGLE PHASE CAPACITORS WITH TWO OUTPUTS (TWIN). CAPACITORS ARE SUPPLIED IN SETS OF THREE TO PROVIDE AN ECONOMICAL UNBALANCE DETECTION SCHEME. THIS IS PARTICULARLY ADVANTAGEOUS IN LOW OUTPUT CAPACITOR BANKS.

TECHNICAL DATA

RATED POWER (MAX.):	600 kVAR, 50 Hz ; 720 kVAR, 60 Hz
RATED VOLTAGE:	1.0 - 20 KV
RATED FREQUENCY:	50 OR 60 Hz
LOSSES TOTAL:	MAX. 0.2 W/kVAR (0.08...0.15 AVERAGE)
DIELECTRIC:	ALL-FILM (HAZY POLYPROPYLENE)
IMPREGNATING FLUID:	ENVIRONMENTALLY COMPATIBLE IMPREGNATING OIL BASED ON M/DBT (NON - PCB)
DISCHARGE RESISTOR:	BUILT IN DISCHARGE RESISTOR REDUCES THE VOLTAGE ON A DE-ENERGISED CAPACITOR FROM THE CREST OF RATED VOLTAGE TO 75 V IN 10 MINUTES OR LESS (DISCHARGE TO 50 V IN 5 MINUTES ON DEMAND).
PERMISSIBLE OVERLOADS:	MAXIMUM PERMISSIBLE CURRENT $1,3 \times I_N$ CONTINUOUSLY MAXIMUM PERMISSIBLE VOLTAGE $1,1 \times U_N$ CONTINUOUSLY, 12 H PER DAY
QUALITY:	ISKRA IS CERTIFIED ACCORDING TO ISO 9001(QUALITY) AND ISO 14001 (ENVIRONMENT)
STANDARDS:	IEC 60871-1, ANSI / IEEE 18, NEMA CP 1

HIGH VOLTAGE POWER CAPACITORS

KLV

ROUTINE TESTS

SEALING TEST:	MINIMUM OF 16 HOURS AT 75°C
VOLTAGE TEST BETWEEN TERMINALS:	2.15 x RATED VOLTAGE AC, 10 s OR 4.3 x RATED VOLTAGE DC, 10 s
AC VOLTAGE TEST BETWEEN TERMINALS AND CONTAINER:	ACCORDING TO IEC 60871-1, TABLE 3, 10 s
DISCHARGE RESISTOR TEST	
MEASUREMENT OF LOSSES (TAN d)	

SERVICE CONDITIONS

TEMPERATURE CATEGORIES UP TO -40 /D

UPPER TEMPERATURE CATEGORY LIMIT	C	D
MAXIMUM	50	55
HIGHEST MEAN OVER 24 H	40	45
HIGHEST MEAN OVER 1 YEAR	30	35
LOW TEMPERATURE LIMIT DURING OPERATION	-25 °C OR -40 °C	

INSTALLATION:	OUTDOOR OR INDOOR
INSTALLATION ALTITUDE (ABOVE SEA LEVEL):	1000 M STANDARD, UP TO 4000 M ON DEMAND
CASE MATERIAL:	STAINLESS STEEL PLATE 1.5 MM THICK
FINISH / COLOUR:	TWO-COMPONENT DURABLE PAINTING RAL 7032 (LIGHT GREY) ON TREATED SURFACES.
FIXING:	DEPENDING ON THE HEIGHT OF CAPACITOR, CONTAINER IS EQUIPED WITH ONE OR TWO MOUNTING BRACKETS ON THE NARROWER SIDES. BRACKETS HAVE MOUNTING SLOTS 11 X 20 mm

TERMINAL & CONNECTIONS

BUSHINGS:	BROWN OR GRAY PORCELAIN BUSHINGS, WELDED TO THE CONTAINER.
THREAD OF TERMINAL STUD:	M14
CURRENT:	110 A MAX.
CONNECTIONS:	TERMINAL CLAMPS WITH PROVISION TO ACCOMMODATE ANY COMBINATION OF 2 CONDUCTORS FROM 4 mm ² SOLID TO 50 mm ² STRANDED WIRE ARE AVAILABLE ON DEMAND*. THE CAPACITOR UNIT GROUNDING IS PROVIDED BY UNPAINTED SURFACE OF MOUNTING BRACKETS.
PRESSURE SWITCH:	WITH TERMINAL CAP SUPPLIED ON DEMAND
NAME PLATE:	DURABLE PLASTIC LABEL WITH PERMANENT PRINTING

NOTE:

* TERMINAL CLAMPS 70 mm² ALSO AVAILABLE ON DEMAND

HIGH VOLTAGE POWER CAPACITORS

KLV 1xx1 AND 3xx1, SINGLE-PHASE CAPACITORS

TYPICAL DIMENSIONS

Q _n at 50 Hz (kVar)	U _n KLV 1xxx (WITHOUT INTERNALLY FUSED) (kV)			U _n KLV 3xxx (INTERNALLY FUSED) (kV)			DIMENSIONS (mm)					WEIGHT (kg)	WEIGHT* (kg)	
							A	B	B*	C	D			
											BIL 75-95 kV			BIL 125 kV
100	2.00	-	16.5 (20)	2.00	-	2.4	145	310	340	120 ^{2R}	240	315	26	28
150	2.00	-	16.5 (20)	2.00	-	4.8	145	400	430	200 ^{2R}	240	315	32	34
200	2.00	-	16.5 (20)	2.00	-	4.8	145	500	550	200 ^{2R}	240	315	39	42
250	2.27	-	16.5 (20)	2.27	-	7.2	145	600	670	200 ^{2R}	240	315	47	50
300	2.72	-	16.5 (20)	2.72	-	7.2	145	720	770	200 ^{2R}	240	315	53	56
350	3.18	-	16.5 (20)	3.18	-	9.6	145	840	870	200 ^{2R}	240	315	60	65
400	3.64	-	16.5 (20)	3.64	-	9.6	145	940	1000	200 ^{2R}	240	315	66	70
450	4.10	-	16.5 (20)	4.10	-	12	175	860	940	100 ^{4R}	240	315	75	78
500	4.56	-	16.5 (20)	4.56	-	14.4	175	920	1000	100 ^{4R}	240	315	82	89
550	5.00	-	16.5 (20)	5.00	-	14.4	190	920	970	100 ^{4R}	240	315	93	98
600	5.46	-	16.5 (20)	5.46	-	14.4	190	1000	1025	100 ^{4R}	240	315	93	98

NOTES:

* DIMENSIONS WITH AN ASTERISK (*) REFER TO INTERNALLY FUSED CAPACITORS

- 1) VOLTAGE IN PARENTHESIS () REFER TO ONE-BUSHING CAPACITORS ONLY
- 2) FOR OUTPUT AND VOLTAGE OUTSIDE THIS RANGE, PLEASE CONTACT FACTORY
- 3) CASE SIZES ARE TYPICAL AND ACTUAL SIZES WILL BE CONFIRMED AT THE TIME OF ORDER
- 4) CAPACITOR CONTAINER COULD HAVE 2 OR 4 BRACKETS (1 OR 2 BRACKETS ON NARROWER SIDE)

DIMENSION C - 2R MEANS 1 BRACKET FROM EACH SIDE (CAPACITOR TYPE KLVXX1X); 4R MEANS 2 BRACKETS ON EACH SIDE, ONE ON THE TOP AND ONE ON THE BOTTOM, EXCEPT WHERE THE HEIGHT IS 310 MM OR BELOW, WHERE BRACKETS ARE ON THE BOTTOM ONLY (TYPE KLVXX2X).

- 5) DIM A MAY EXPAND UP TO 115% DUE TO THERMAL FLEXURE
- 6) POWER AT 60 HZ = 1.2 X POWER AT 50 HZ

PICTURE 1: TWO - BUSHING CAPACITOR KLVXXX1 (INSULATED CONTAINER)

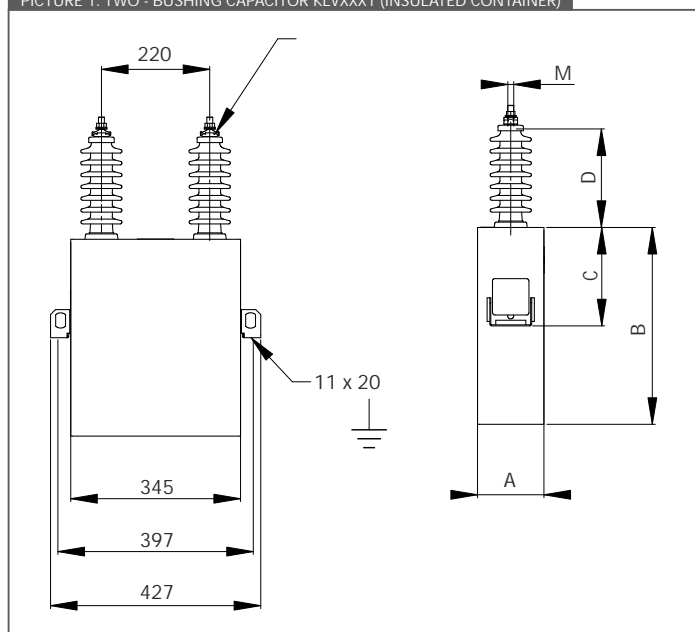

PICTURE 2: SINGLE - BUSHING CAPACITOR KLVXXX0 (VOLTAGE ON THE CONTAINER)

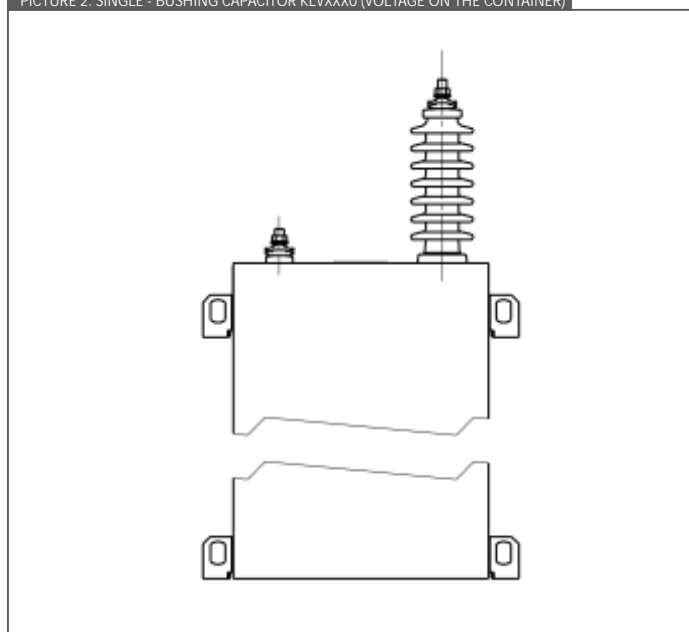

WHILE EVERY CARE HAS BEEN TAKEN TO ENSURE THAT THE INFORMATION CONTAINED IN THIS DOCUMENT IS CORRECT, NO RESPONSIBILITY CAN BE ACCEPTED FOR ANY INACCURACY. WE RESERVE THE RIGHT TO ALTER OR MODIFY THE INFORMATION CONTAINED HEREIN AT ANY TIME IN THE LIGHT OF TECHNICAL OR OTHER DEVELOPMENTS. TECHNICAL SPECIFICATIONS ARE VALID UNDER NORMAL OPERATING CONDITIONS ONLY. WE DO NOT ACCEPT ANY RESPONSIBILITY FOR ANY MISUSE OF THE PRODUCT AND CANNOT BE HELD LIABLE FOR INDIRECT OR CONSEQUENTIAL DAMAGES. TECHNICAL DATA AND DESIGN CAN BE SUBJECT TO CHANGE AND SHOULD BE CONFIRMED PRIOR TO ORDERING.

HIGH VOLTAGE POWER CAPACITORS

KLV 1xx3 AND 3xx3, THREE-PHASE CAPACITORS

BIL 20/60 kV

TYPICAL DIMENSIONS (PICTURE 3)								
U _n (kV)	Q _n at 50 Hz (kVar)	Dimensions (mm)					Weight (kg)	Weight* (kg)
		A	B	B*	D	E		
3.3 - 7.2	50	145	200	200	190	240	16	20
	100	145	290	325	190	240	23	26
	150	145	415	430	190	240	30	33
	200	145	520	550	190	240	37	42
	250	145	620	670	190	240	44	49
	300	145	740	770	190	240	51	55
	350	145	825	900	190	240	60	63
	400	145	940	1000	190	240	66	71
	450	175	870	960	190	240	73	78

BIL 28/75 kV

TYPICAL DIMENSIONS (PICTURE 4)								
U _n (kV)	Q _n at 50 Hz (kVar)	Dimensions (mm)					Weight (kg)	Weight* (kg)
		A	B	B*	D	E		
UP TO 12	50	145	200	200	300	510	22	23
	100	145	290	310	300	510	28	29
	150	145	400	430	300	510	35	37
	200	145	500	550	300	510	42	44
	250	145	600	670	300	510	49	51
	300	145	720	770	300	510	55	60
	350	145	825	870	300	510	63	66
	400	145	940	1000	300	510	69	75
	450	175	840	940	300	510	76	82

NOTES:

- * DIMENSIONS WITH AN ASTERISK (*) REFER TO INTERNALLY FUSED CAPACITORS
- 1) FOR OUTPUT AND VOLTAGE OUTSIDE THIS RANGE, PLEASE CONTACT FACTORY
- 2) CASE SIZES ARE TYPICAL AND ACTUAL SIZES WILL BE CONFIRMED AT THE TIME OF ORDER
- 3) PRESSURE SWITCH ON DEMAND
- 4) EITHER 2 OR 4 FIXING BRACKETS ARE USED, DEPENDING ON THE HEIGHT OF THE UNIT. SPECIAL BRACKET POSITIONS CAN BE PROVIDED IF REQUIRED. PLEASE SPECIFY AT THE ENQUIRY STAGE.
- 5) DIM A MAY EXPAND UP TO 115 % DUE TO THERMAL FLEXURE
- 6) POWER AT 60 HZ = 1.2 x POWER AT 50 HZ

HIGH VOLTAGE POWER CAPACITORS

KLV 1xx3 AND 3xx3, THREE-PHASE CAPACITORS

PICTURE 3

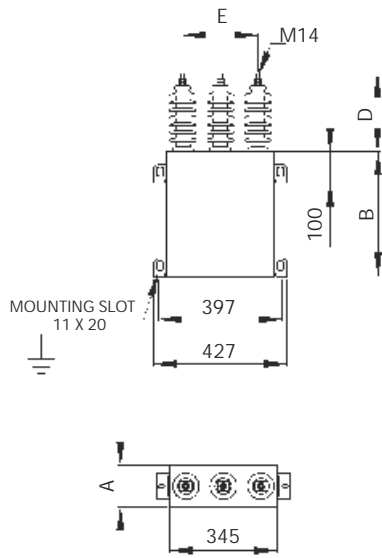

PICTURE 4

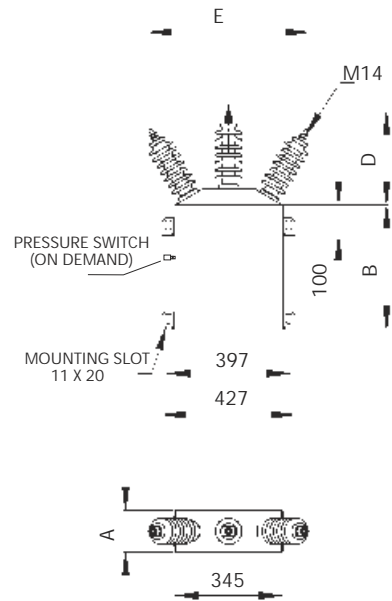

WHILE EVERY CARE HAS BEEN TAKEN TO ENSURE THAT THE INFORMATION CONTAINED IN THIS DOCUMENT IS CORRECT, NO RESPONSIBILITY CAN BE ACCEPTED FOR ANY INACCURACY. WE RESERVE THE RIGHT TO ALTER OR MODIFY THE INFORMATION CONTAINED HEREIN AT ANY TIME IN THE LIGHT OF TECHNICAL OR OTHER DEVELOPMENTS. TECHNICAL SPECIFICATIONS ARE VALID UNDER NORMAL OPERATING CONDITIONS ONLY. WE DO NOT ACCEPT ANY RESPONSIBILITY FOR ANY MISUSE OF THE PRODUCT AND CANNOT BE HELD LIABLE FOR INDIRECT OR CONSEQUENTIAL DAMAGES. TECHNICAL DATA AND DESIGN CAN BE SUBJECT TO CHANGE AND SHOULD BE CONFIRMED PRIOR TO ORDERING.

HIGH VOLTAGE POWER CAPACITORS

KLV 1xx4 AND 3xx4, SINGLE-PHASE CAPACITORS WITH TWO OUTPUTS (TWIN)

BIL 20/60 kV

TYPICAL DIMENSIONS (PICTURE 5)								
U _n (kV)	Q _n at 50 Hz (kVar)	Dimensions (mm)					Weight (kg)	Weight* (kg)
		A	B	B*	D	E		
2.0 - 4.16	50 (2x25)	135	200	220	250	240	22	23
	100 (2x50)	145	290	310	250	240	28	29
	150 (2x75)	145	400	430	250	240	35	37
	200 (2x100)	145	500	550	250	240	42	44
	250 (2x125)	145	620	640	250	240	49	51
	300 (2x150)	145	720	770	250	240	51	55
	400 (2x200)	145	940	1000	250	240	66	71

BIL 28/75 kV

TYPICAL DIMENSIONS (PICTURE 6)								
U _n (kV)	Q _n at 50 Hz (kVar)	Dimensions (mm)					Weight (kg)	Weight* (kg)
		A	B	B*	D	E		
UP TO 6.93	50 (2x25)	145	180	200	300	510	22	23
	100 (2x50)	145	290	330	300	510	28	29
	150 (2x75)	145	400	440	300	510	35	37
	200 (2x100)	145	500	550	300	510	42	44
	250 (2x125)	145	590	670	300	510	49	51
	300 (2x150)	145	690	770	300	510	55	60
	400 (2x200)	145	900	1000	300	510	69	75

NOTES:

* DIMENSIONS WITH AN ASTERISK (*) REFER TO INTERNALLY FUSED CAPACITORS

- 1) FOR OUTPUT AND VOLTAGE OUTSIDE THIS RANGE, PLEASE CONTACT FACTORY
- 2) CASE SIZES ARE TYPICAL AND ACTUAL SIZES WILL BE CONFIRMED AT THE TIME OF ORDER
- 3) EITHER 2 OR 4 FIXING BRACKETS ARE USED, DEPENDING ON THE HEIGHT OF THE UNIT. SPECIAL BRACKET POSITIONS CAN BE PROVIDED IF REQUIRED. PLEASE SPECIFY AT THE ENQUIRY STAGE. 4) DIM A MAY EXPAND UP TO 115 % DUE TO THERMAL FLEXURE
- 5) POWER AT 60 HZ = 1.2 x POWER AT 50 HZ

HIGH VOLTAGE POWER CAPACITORS

KLV 1xx4 AND 3xx4, SINGLE-PHASE CAPACITORS WITH TWO OUTPUTS (TWIN)

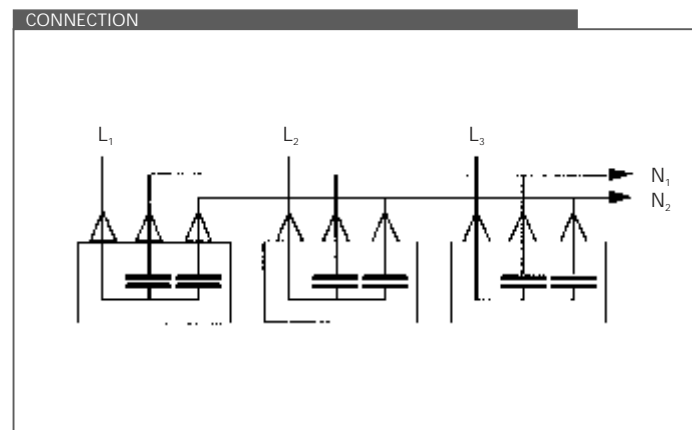
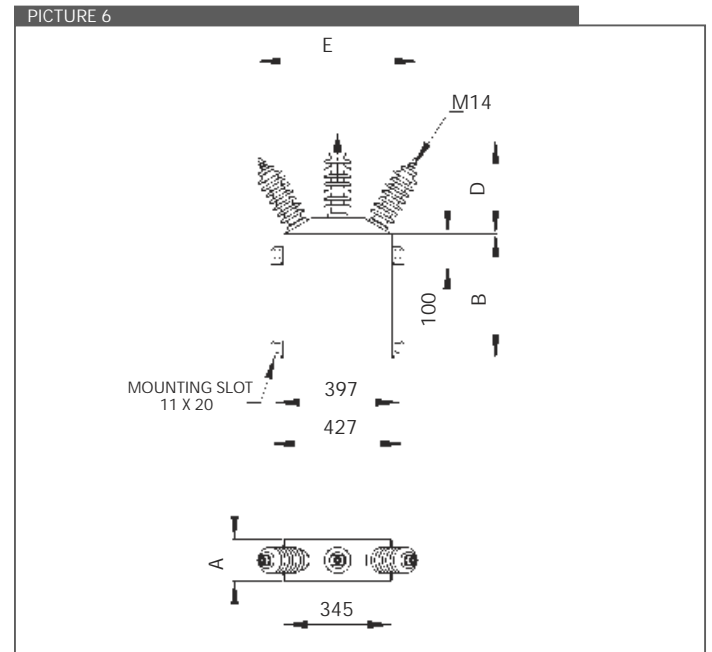
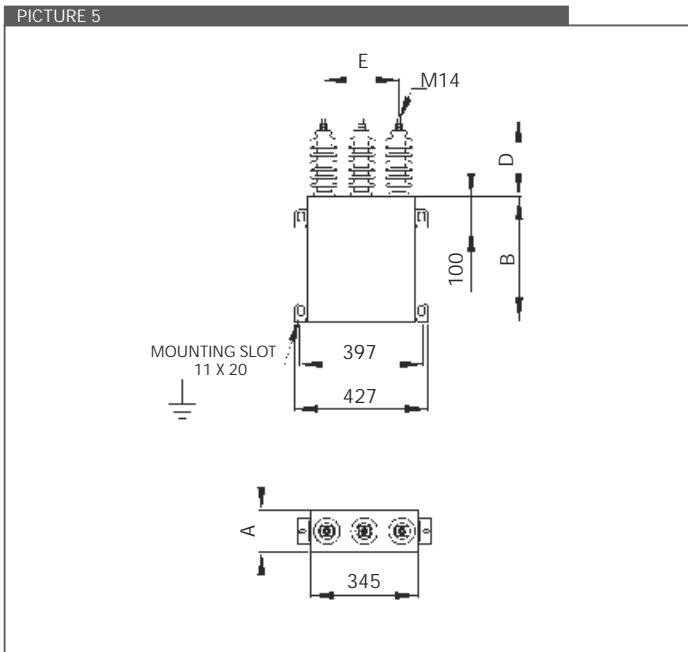

WHILE EVERY CARE HAS BEEN TAKEN TO ENSURE THAT THE INFORMATION CONTAINED IN THIS DOCUMENT IS CORRECT, NO RESPONSIBILITY CAN BE ACCEPTED FOR ANY INACCURACY. WE RESERVE THE RIGHT TO ALTER OR MODIFY THE INFORMATION CONTAINED HEREIN AT ANY TIME IN THE LIGHT OF TECHNICAL OR OTHER DEVELOPMENTS. TECHNICAL SPECIFICATIONS ARE VALID UNDER NORMAL OPERATING CONDITIONS ONLY. WE DO NOT ACCEPT ANY RESPONSIBILITY FOR ANY MISUSE OF THE PRODUCT AND CANNOT BE HELD LIABLE FOR INDIRECT OR CONSEQUENTIAL DAMAGES. TECHNICAL DATA AND DESIGN CAN BE SUBJECT TO CHANGE AND SHOULD BE CONFIRMED PRIOR TO ORDERING.

HIGH VOLTAGE POWER CAPACITORS

KLV

ORDERING DATA

TYPE DESIGNATION DATA:

	A1	A2	A3	A4	A5-A6	A7
K						
DIELECTRIC						
APPLICATION						
INTERNAL DEVICES						
CASE MATERIAL AND FINISH						
NUMBER OF TERMINALS, CONNECTION						

A1	K	CAPACITOR
A2	L	DIELECTRIC POLYPROPYLENE (ALL-FILM)
A3	V	HIGH VOLTAGE CAPACITOR FOR POWER FACTOR CORRECTION
A4	1	DISCHARGE RESISTOR BUILT IN
	2	WITHOUT DISCHARGE RESISTORS
	3	INTERNAL FUSES AND DISCHARGE RESISTORS BUILT IN
	4	INTERNAL FUSES BUILT IN
A5	0	ORDINARY STEEL CASE COATED WITH PRIMER AND TOP COAT (INTENDED FOR INDOOR INSTALLATION)
	2	STAINLESS STEEL CASE COATED WITH PRIMER AND TOP COAT (INTENDED FOR OUTDOOR AND AGGRESSIVE ATMOSPHERE INSTALLATION)
A6	1	CASE SIDE MOUNTING (2 BRACKETS)
	2	CASE SIDE MOUNTING (2 BRACKETS ON THE TOP AND / OR 2 BRACKETS ON THE BOTTOM)
A7	0	SINGLE PHASE, ONE BUSHING CAPACITOR
	1	SINGLE-PHASE, TWO BUSHING CAPACITOR
	3	THREE PHASE CAPACITOR
	4	SINGLE PHASE CAPACITOR WITH TWO OUTPUTS

WHEN ORDERING, PLEASE STATE:

RATED OUTPUT	kVar
RATED VOLTAGE	V
RATED FREQUENCY	Hz
TOLERANCE OF CAPACITANCE	-...% / +...%
NUMBER OF BUSHINGS	SINGLE BUSHING, TWO BUSHINGS...
INSTALLATION	INDOOR/OUTDOOR
INSULATION LEVEL	.../...kV, IF HIGHER THAN REQUIRED BY U
INTERNAL FUSES	YES/NO
PRESSURE SWITCH	YES/NO
TERMINAL CLAMPS	YES/NO

WHILE EVERY CARE IS TAKEN TO ENSURE THAT THE INFORMATION CONTAINED IN THIS PUBLICATION IS CORRECT, NO LEGAL RESPONSIBILITY CAN BE ACCEPTED FOR ANY INACCURACY. THE COMPANY RESERVES THE RIGHT TO ALTER OR MODIFY THE INFORMATION CONTAINED HEREIN AT ANY TIME IN THE LIGHT OF TECHNICAL OR OTHER DEVELOPMENTS.

INDUCTION HEATING CAPACITORS

KLS



ADVANCED TECHNOLOGY OF LOW LOSS KLS CAPACITOR UNITS IS BASED ON CONSTRUCTION OF ALL-FILM CAPACITOR SECTIONS AND IMPREGNATION WITH ENVIRONMENTALLY COMPATIBLE INSULATING OIL (NON-PCB).

APPLICATIONS

KLS CAPACITORS ARE ESPECIALLY DESIGNED FOR INDUCTIVE HEAT GENERATING PLANTS OPERATING AT FREQUENCIES BETWEEN 50 AND 10000 HZ. MANUFACTURED BY REQUEST, THESE CAPACITORS ARE DESIGNED TO COMPLY WITH THE SPECIFIC REQUIREMENTS OF EACH CUSTOMER. MOST OF THESE CAPACITORS PROVIDE FOR STEP CHANGES IN KVAR BY VIRTUE OF TERMINATED SECTIONS WITHIN EACH UNIT. THIS ALLOWS FOR THE TUNING OF THE CIRCUIT FOR CHANGING INDUCTIVE LOADS.

CONSTRUCTION

KLS CAPACITORS UTILIZE A POLYPROPYLENE FILM AND ALUMINUM FOIL CONSTRUCTION WITH NON-PCB LIQUID IMPREGNANT. THE IMPREGNATING FLUID M/DBT AND TEXTURED POLYPROPYLENE FILM HAVE EXCEPTIONAL DIELECTRIC PROPERTIES OVER THE ENTIRE OPERATING TEMPERATURE RANGE OF INDUCTION HEATING CAPACITORS.

THE EXTENDED FOIL DESIGN OF CAPACITOR ELEMENTS MAKES NEARLY CONTINUOUS CONNECTION TO THE FOILS, SO CAPACITOR OVERCURRENT AND COOLING CAPABILITIES ARE INCREASED.

KLS CAPACITORS DESIGNED FOR OPERATING AT LOWER FREQUENCIES ARE AIR COOLED. MEDIUM FREQUENCY CAPACITORS UTILIZE INTERNAL TUBES FOR COOLING. BUSHINGS AND CONNECTION FOR COOLING WATER ARE PLACED ON CAPACITOR CASE COVER.

SAFETY REQUIREMENTS

THE STANDARD CAPACITOR DOES NOT HAVE INTERNAL DISCHARGE DEVICES - ALL CAPACITOR UNITS SHOULD BE CONNECTED DIRECTLY WITH A DISCHARGE DEVICE, THIS MAY BE OTHER ELECTRICAL EQUIPMENT CONNECTED DIRECTLY ACROSS THE CAPACITOR (I.E. FURNACE COIL). THE DISCHARGE PATH MUST NOT HAVE A DISCONNECTING SWITCH OR FUSES.

WHEN THE CAPACITORS IS SWITCHED OFF AND RE-ENERGIZED AT SHORT INTERVALS, ARRANGEMENTS SHOULD BE MADE SO THAT, AT THE TIME OF RE-APPLICATION OF THE VOLTAGE, THE CAPACITOR TERMINAL VOLTAGE SHALL NOT BE MORE THAN 10% OF THE RATED VOLTAGE OF THE CAPACITOR.

BEFORE WORKING ON A CAPACITOR ENSURE THAT THE CAPACITOR BANK IS PROPERLY ISOLATED, WAIT TO ENSURE THE CAPACITOR IS DISCHARGED AND SHORT CIRCUIT THE CAPACITOR TERMINALS BEFORE HANDLING.

QUALITY ASSURANCE

ALL CAPACITORS ARE SUBJECTED TO THE FOLLOWING ROUTINE TESTS:

- SEALING TEST ON CONTAINER
- SHORT CIRCUIT DISCHARGE TEST $1.7 \times$ RATED VOLTAGE DC, ONE DISCHARGE, FOR INTERNALLY FUSED CAPACITORS
- CAPACITANCE MEASUREMENTS
- LOSS MEASUREMENTS AT 50 HZ
- VOLTAGE TEST BETWEEN TERMINALS AT $2.0 \times$ RATED VOLTAGE AC, 10 SEC OR $4.0 \times$ RATED VOLTAGE DC, 10 SEC.
- VOLTAGE TEST TERMINALS TO CONTAINER WHERE APPLICABLE
- CAPACITORS COMPLY WITH IEC 60110-1 AND VDE 0560 PART 9.

INDUCTION HEATING CAPACITORS

KLS xOxx, KLS x1xx - AIR COOLED

50 / 60 Hz

TECHNICAL DATA			
VOLTAGE RANGE	U_n	V	500 - 3000
OUTPUT RANGE	Q_n	kVar	UP TO 600
RATED FREQUENCY	f_n	Hz	50/60
TOLERANCE OF CAPACITY			-5 % . . . +10 % (NARROWER TOLERANCES ON REQUEST)
LOSSES (TYPICAL)		W/kVar	0.15 - 0.3
TEMPERATURE CATEGORY (AMBIENT TEMPERATURE)		° C	-25 / +45 % (AIR-COOLED CAPACITORS)
IMPREGNATING FLUID			BIODEGRADABLE NON-PCB DIELECTRIC OIL BASED ON M/DBT
DISCHARGE RESISTORS			ON DEMAND
INTERNAL FUSES			BUILT IN, WITHOUT FUSES ON DEMAND
TEMPERATURE MONITORING			TEMPERATURE SENSORS CAN BE BUILT-IN UPON REQUEST
PRESSURE MONITORING			PRESSURE SWITCHES CAN BE BUILT-IN UPON REQUEST
CASE MATERIAL			MILD STEEL OR STAINLESS STEEL
CASE FINISH			ONE LAYER OF TOP COAT ON ONE LAYER OF PRIMER. STANDARD COLOUR RAL 7032.
DIMENSIONS			DIM A : 110 - 165 mm, DIM B : UP TO 1000 mm ACTUAL SIZES WILL BE CONFIRMED AT THE TIME OF ORDER

PICTURE 1 - KLS X12X AIR COOLED CAPACITORS 50/60 HZ

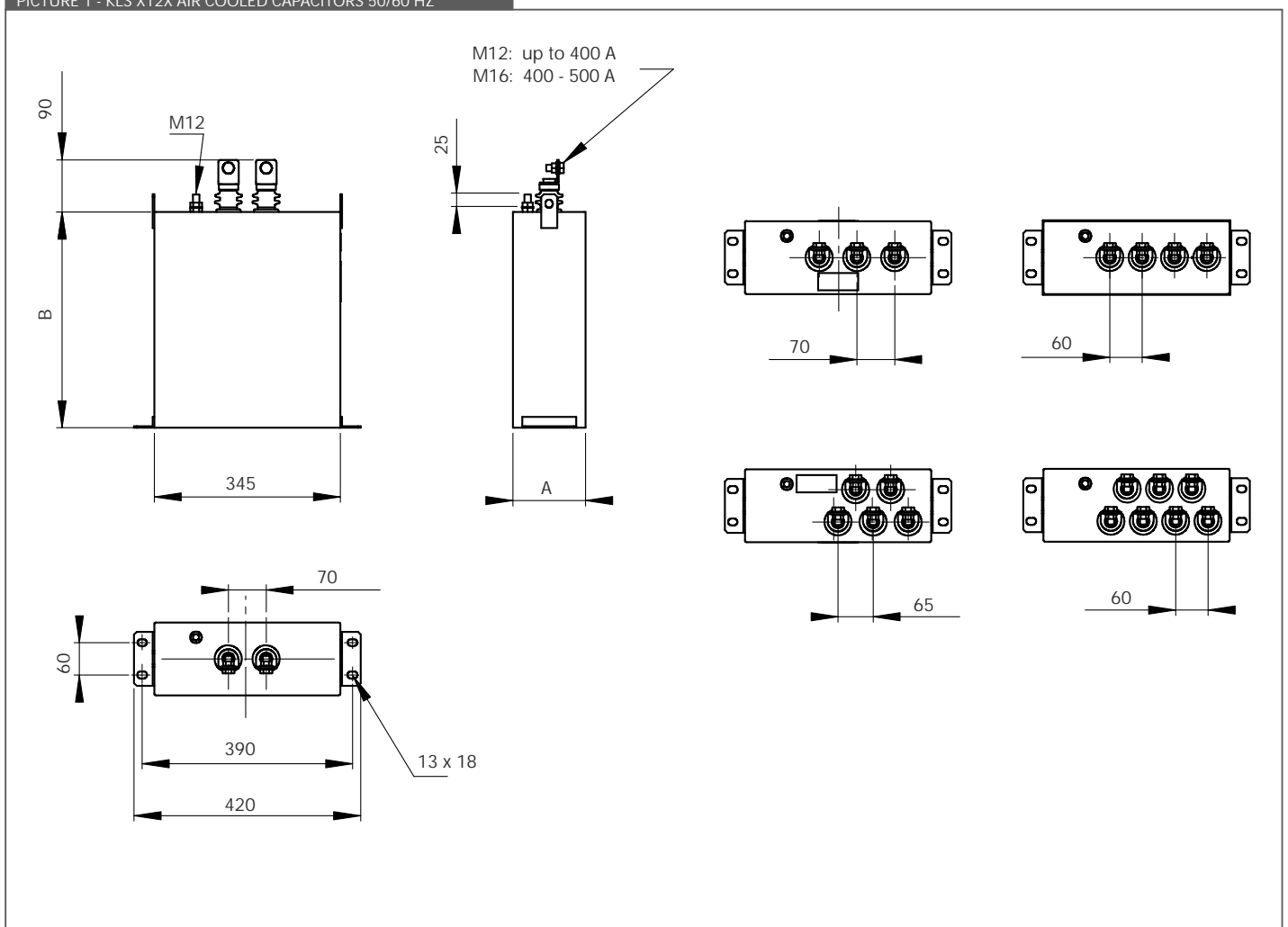

INDUCTION HEATING CAPACITORS

KLS x2xx, x3xx, x4xx - WATER COOLED

180 ... 10000 Hz



TECHNICAL DATA

VOLTAGE RANGE	U_n	V	100 - 3000
OUTPUT RANGE	Q_n	kVar	UP TO 3000
RATED FREQUENCY	f_n	Hz	150 ... 10000
TOLERANCE OF CAPACITY			-10 % ... +10 % (NARROWER TOLERANCES ON REQUEST)
LOSSES (TYPICAL)		W/kVar	0.2 - 0.7
TEMPERATURE CATEGORY (AMBIENT TEMPERATURE)		° C	+1 / +45 % (WATER COOLED CAPACITORS)
OUTLET WATER TEMPERATURE		° C	45 MAX.
MAX. PRESSURE OF INCOMING COOLING WATER		bar	8
COOLING WATER FLOW		l/min	4.5 - 12.5
IMPREGNATING FLUID			BIODEGRADABLE NON-PCB DIELECTRIC OIL BASED ON M/DBT
DISCHARGE RESISTORS			NO
INTERNAL FUSES			NO
TEMPERATURE MONITORING			TEMPERATURE SENSORS CAN BE BUILT-IN UPON REQUEST
PRESSURE MONITORING			PRESSURE SWITCHES CAN BE BUILT-IN UPON REQUEST
CASE MATERIAL			BRASS OR ALUMINIUM CONTAINERS FOR MEDIUM FREQUENCY CAPACITORS
CASE FINISH			ONE LAYER OF TOP COAT ON ONE LAYER OF PRIMER. STANDARD COLOUR RAL 7032.
DIMENSIONS			DIM A : 110 - 165 mm, DIM B : UP TO 1000 mm ACTUAL SIZES WILL BE CONFIRMED AT THE TIME OF ORDER
NUMBER OF TAPS			UP TO 8

INDUCTION HEATING CAPACITORS

KLS x2xx, x3xx, x4xx - WATER COOLED

PICTURE 2 - KLS X3XX SINGLE COOLING COIL CAPACITOR (INSULATED POLES, "DEAD" CASE)

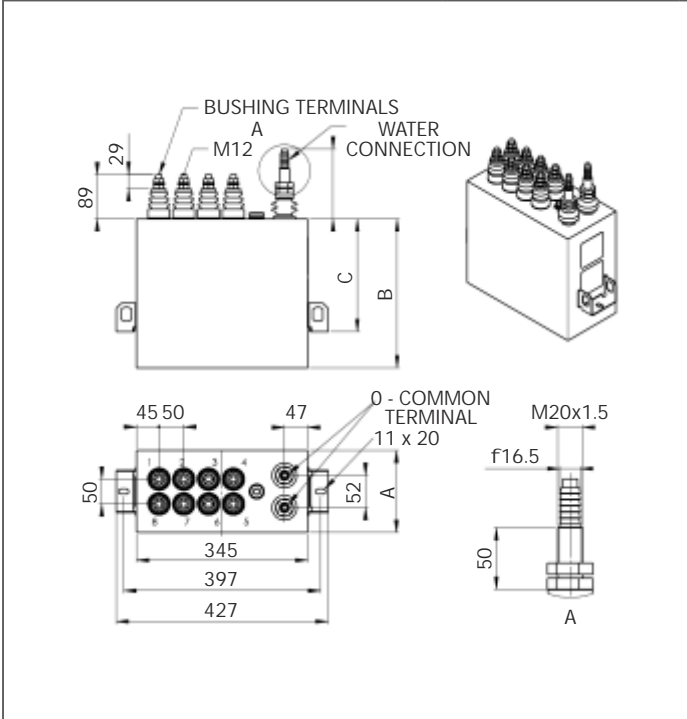

PICTURE 3 - KLS X2XX SINGLE COOLING COIL CAPACITOR ("LIVE" CASE)HZ

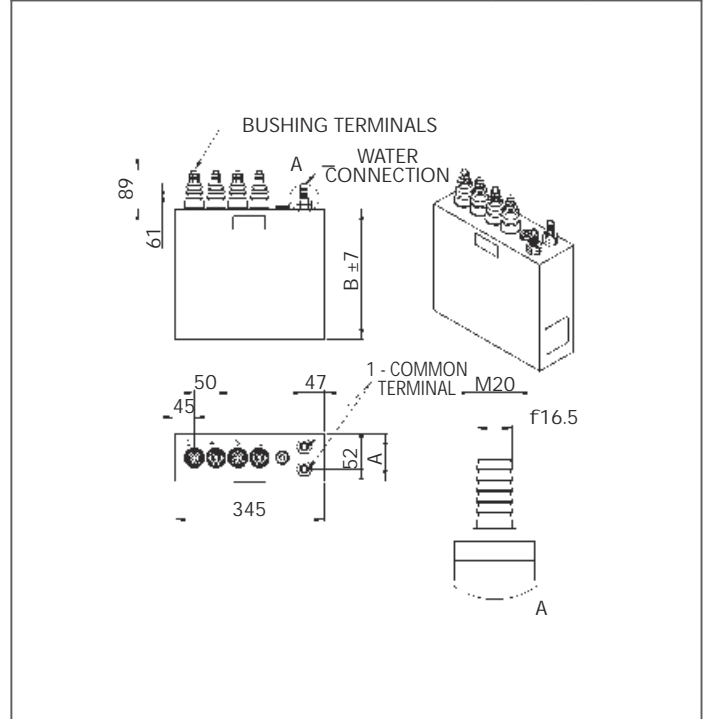

PICTURE 4 - KLS X400 DOUBLE COOLING COILS CAPACITOR - "DEAD"

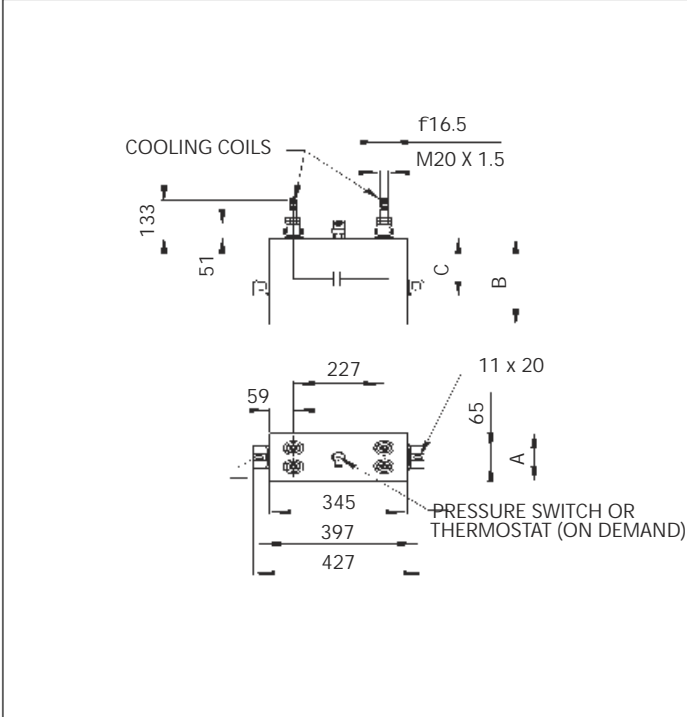

PICTURE 5 - KLS X200 DOUBLE COOLING COILS CAPACITOR - "LIVE" CASE

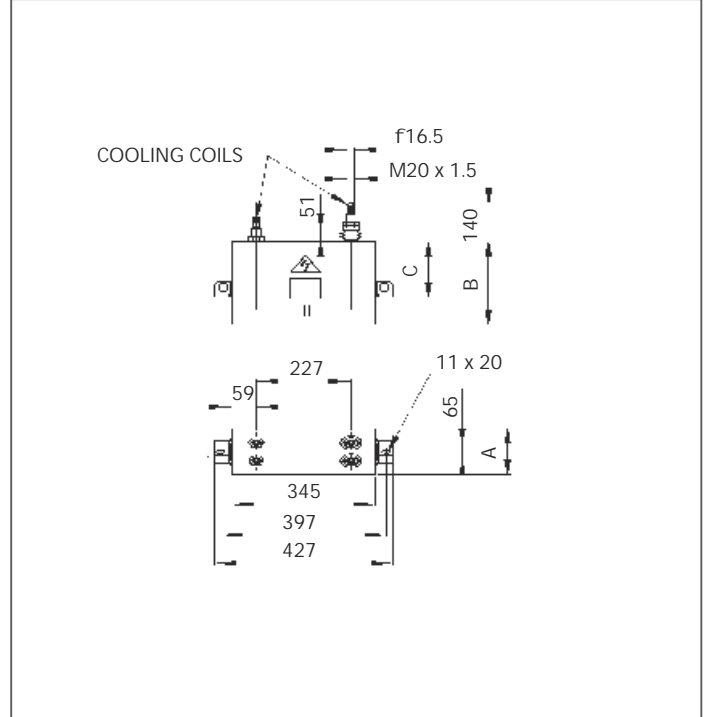

INDUCTION HEATING CAPACITORS

KLS

ORDERING DATA

TYPE DESIGNATION DATA:

	A1	A2	A3	A4	A5	A6	A7
K							
DIELECTRIC							
APPLICATION							
INTERNAL DEVICES							
CONSTRUCTION							
CONTAINER							
NUMBER OF TERMINALS, CONNECTION							

A1	K	CAPACITOR
A2	L	DIELECTRIC POLYPROPYLENE (ALL-?LM)
A3	S	INDUCTION HEATING CAPACITOR
	1	DISCHARGE RESISTORS BUILT IN
	2	WITHOUT DISCHARGE RESISTORS
	3	INTERNAL FUSES AND DISCHARGE RESISTORS BUILT IN
A4	4	INTERNAL FUSES BUILT IN
	5	DISCHARGE RESISTORS AND THERMOSTAT OR PRESSURE SWITCH BUILT-IN
	6	THERMOSTAT OR PRESSURE SWITCH BUILT-IN
	7	INTERNAL FUSES, DISCHARGE RESISTORS AND THERMOSTAT OR PRESSURE SWITCH BUILT-IN
	8	INTERNAL FUSES, AND THERMOSTAT OR PRESSURE SWITCH BUILT-IN
	0	AIR COOLED, COMMON TERMINAL ON THE CASE (»LIVE CASE«)
	1	AIR COOLED, ISOLATED TERMINALS
A5	2	WATER COOLED, COMMON TERMINAL ON THE CASE (»LIVE CASE«)
	3	WATER COOLED, ISOLATED TERMINALS
	4	WATER COOLED, TWO COILING COILS, ISOLATED TERMINAL
A6	0	CASE SIDE MOUNTING
	2	CASE BOTTOM MOUNTING
A7	0	NUMBER OF TERMINALS

INDUCTION HEATING CAPACITORS

KLS

When ordering, please state:

RATED OUTPUT	kVar
RATED VOLTAGE	V
RATED FREQUENCY	Hz
TOLERANCE OF CAPACITANCE	-...% / +...%
COOLING	air / water
TERMINAL CONNECTION	one terminal connected to the case ("live") / isolated ("dead")
NUMBER OF BUSHINGS	
INTERNAL FUSES	Yes/No
DISCHARGE RESISTORS	Yes/No
THERMOSTAT	Yes/No
PRESSURE SWITCH	Yes/No
SPECIAL CONDITIONS	
STANDARDS AND REGULATIONS	

WHILE EVERY CARE IS TAKEN TO ENSURE THAT THE INFORMATION CONTAINED IN THIS PUBLICATION IS CORRECT, NO LEGAL RESPONSIBILITY CAN BE ACCEPTED FOR ANY INACCURACY. THE COMPANY RESERVES THE RIGHT TO ALTER OR MODIFY THE INFORMATION CONTAINED HEREIN AT ANY TIME IN THE LIGHT OF TECHNICAL OR OTHER DEVELOPMENTS.

CAPACITOR DUTY CONTACTORS

KC12, KC16, KC20, KC25, KC33, KC40, KC60



SWITCHING OF CAPACITORS IN SYSTEMS FOR COMPENSATION OF REACTIVE ENERGY (CLASSIC AUTOMATION DEVICES).

FEATURES

- CONFORMS TO UTILIZATION CATEGORY AC-6B
- STANDARD CONTROL VOLTAGES:
24 V 50/60 HZ, 220 V 50/60 HZ, 230 V 50/60 HZ, 415 V 50/60 HZ
- SAVES COSTS OF EXPENSIVE REPLACEMENT
- LONG ELECTRICAL LIFE
- REDUCES WATT LOSSES DURING "ON" CONDITION, SAVES ENERGY
- HIGH SAFETY
- NO RISK OF DANGEROUS VOLTAGE
- SWITCHING OF CAPACITOR BANK IN PARALLEL WITHOUT DE-RATING
- LESS MAINTENANCE AND DOWNTIME
- APPROVALS: CSA

TECHNICAL DATA

TYPE	RATING AT 50/60 Hz (kVar)	CURRENT CARRYING CAPACITY							POWER DISSIPATION PER POLE	MECHANICAL LIFE		ELECTRICAL LIFE
	≤ 55°C *	220 - 240 V		400 440 V		kVar / CURRENT RATING AS PER UL (kVar/A)				50 OR 60 Hz	50 / 60 Hz	
		kVar	CURRENT AT 230 V (A)	kVar	CURRENT AT 400 V (A)	240 V	480 V	600 V	W	MILLION		OPERATIONS
KC12-11	12.5	6.7	17.6	12.5	18.1	6 / 15	12.5 / 15	15 / 15	0.36	17	15	200.000
KC16-11	16.7	8.5	22.3	16.7	24.1	8 / 20	16.7 / 20	20 / 20	0.8	20	15	200.000
KC20-11	20	10	26.2	20	28.9	10 / 24	20 / 24	25 / 24	1.25	16	12	100.000
KC25-11	25	15	39.4	25	36.1	12.5 / 30	25 / 30	33.3 / 30	2	16	12	100.000
KC33-12	33.3	20	52.5	33.3	48.1	16.5 / 40	33.3 / 40	40 / 40	4.2	16	6	100.000
KC40-12	40	25	65.6	40	57.7	20 / 48	40 / 48	50 / 48	4.2	16	6	100.000
KC60-12	60	40	104.9	60	86.6	30 / 72	60 / 72	80 / 77	5.1	10	4	100.000

NOTES:

KC12 TO KC25; CLIP- ON MOUNTING ON 35 mm WIDE RAIL
KC33 TO KC60; CLIP-ON MOUNTING ON 75 mm WIDE RAIL

* AVERAGE AMBIENT TEMPERATURE SHOULD NOT EXCEED 45 °C WITHIN THE 24-HOUR PERIOD IN ACC. WITH IEC 60 070 AND IEC 60 831

TECHNICAL DATA

TYPE	RATING AT 50/60 Hz (kvar)	UPPER BLOCK		Wire details						COIL CONSUMPTION		
	≤ 55°C	TIME LAG BETWEEN MAKE CONTACTS OF AUX. BLOCK AND CONTACTOR	HOLDING TIME OF MAIN CONTACTS OF AUX. BLOCK	CROSS-SECTIONAL AREA	LENGHT	MATERIAL	LUGS - AT CONTACTOR END	LUGS AT AUX. BLOCK END	TIGHTENING TORQUE	50 Hz	60 Hz	50 / 60 Hz
										ms	ms	mm ²
KC12-11	12.5	2 - 10	5 - 12	0.292	174	PTFE COATED RESISTANCE WIRE	RING TYPE LUG	PIN TYPE LUG	1.2	7	7.5	8
KC16-11	16.7	2 - 10	5 - 12	0.292	174				1.7	7	7.5	8
KC20-11	20	2 - 10	5 - 12	0.292	174				1.85	7.5	7.5	8.5
KC25-11	25	2 - 10	5 - 12	0.292	174				2.5	7.5	7.5	8.5
KC33-12	33.3	2 - 10	5 - 12	0.196	245				5	20	22	26
KC40-12	40	2 - 10	5 - 12	0.196	245				5	20	22	26
KC60-12	60	2 - 10	5 - 12	0.196	245	5	20	22				

CAPACITOR DUTY CONTACTORS

KC12, KC16, KC20, KC25, KC33, KC40, KC60

DIMENSIONS

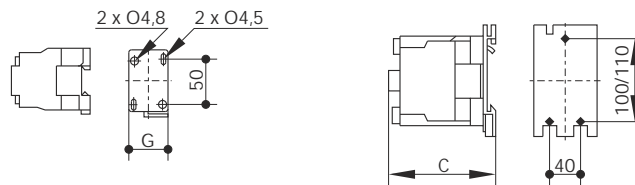
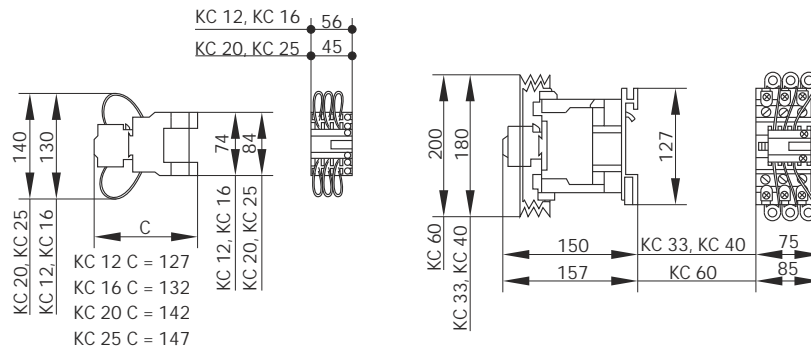

KC 12	2,5	1,5	4	4			1,2
KC 16	4	2,5	6	6			1,7
KC 20	4	4	10	6			1,85
KC 25	6	4	16	10			2,5
KC 33	16	6	25	16		5	
KC 40	16	6	25	16		5	
KC 60	50	25	50	35	10	9	

PHILIPS N°2
Ø6...Ø8

AWG 16 = 1,31 mm²
 AWG 14 = 2,08 mm²
 AWG 12 = 3,31 mm²
 AWG 10 = 5,26 mm²
 AWG 8 = 8,37 mm²
 AWG 5 = 13,3 mm²
 AWG 4 = 21,15 mm²
 AWG 3 = 26,31 mm²
 AWG 2 = 33,62 mm²
 AWG 1 = 42,41 mm²
 AWG 1/0 = 53,49 mm²

ORDERING DATA

THE TYPE DESIGNATION AND CONTROL VOLTAGE ARE STATED WHEN ORDERING THE CONTACTORS.

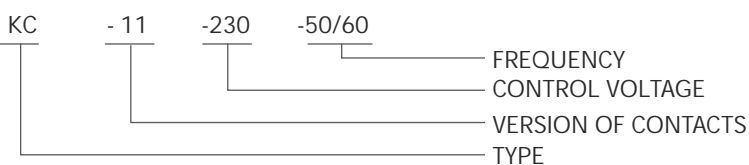

POWER FACTOR CONTROL RELAY

PFCMAX 6, PFCMAX 12



POWER FACTOR REGULATORS PFCMAX6 (6 STEPS) AND PFCMAX12 (12 STEPS) MEASURE $\cos \varphi$ OF A SUPPLY SYSTEM AND CONTROL THE AUTOMATIC CONNECTION AND DISCONNECTION OF COMPENSATION CAPACITORS ACCORDING TO DESIRED $\cos \varphi$.

FEATURES

- FCP (FAST COMPUTERIZED PROGRAM) SYSTEM MINIMIZING THE NUMBER OF CAPACITOR CONNECTIONS AND DISCONNECTIONS
- 6 AND 12 RELAY REGULATORS ACCORDING TO THE TYPE
- CONNECTED STEP DISPLAY, A DIGITAL DISPLAY FOR $\cos \varphi$ AND DIFFERENTIATION OF A SIGN FOR REACTIVE POWER L (INDUCTIVE) AND C (CAPACITIVE)
- THREE-DIGIT LCD WITH SEVEN SEGMENTS
- SETTING OF PARAMETERS WITHOUT THE NEED FOR DISCONNECTING THE REGULATOR POWER SUPPLY
- OPTION TO CONFIGURE THE REGULATOR EVEN WHEN IT IS STILL IN THE PROCESS OF REGULATING THE CAPACITORS
- OPTION FOR USING 50 OR 60 HZ FREQUENCIES
- ALL MEASUREMENTS DISPLAYED ON ONE SINGLE DISPLAY
- EASY TO MOUNT WITH NO NEED FOR TOOLS
- PROGRAMMING FROM KEYPAD ON THE FRONT: (3 KEYS)
- SIZE 144 X 144 mm ACCORDING TO DIN 43 700
- MEASUREMENT AND POWER SUPPLY IN ONE SINGLE INPUT

PFCMAX 6

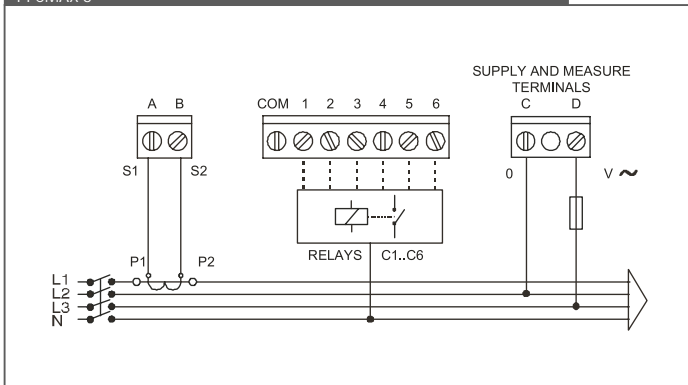

PFCMAX 12

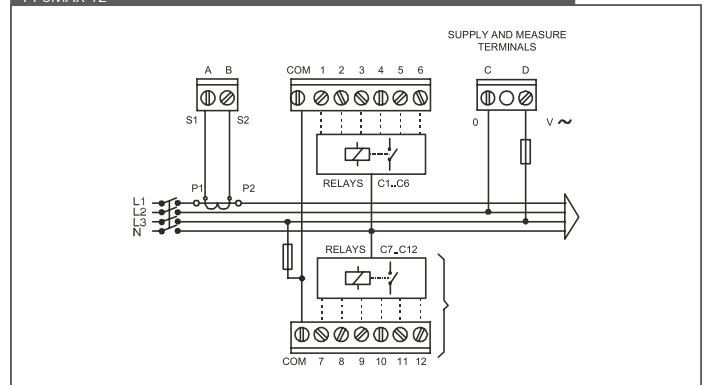

DIMENSIONS

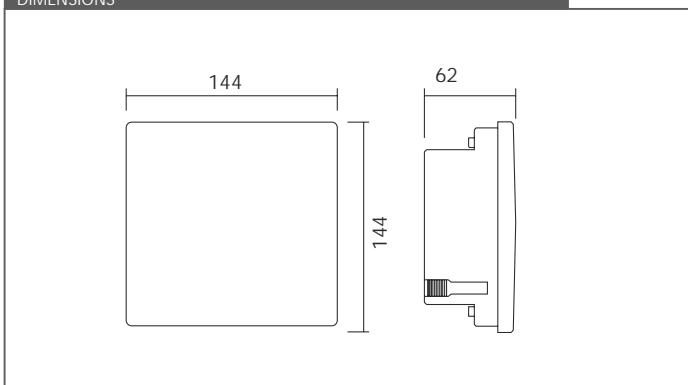

POWER FACTOR CONTROL RELAY

PFC-CX



POWER FACTOR CONTROL RELAY PFC-CX MEASURE $\cos \varphi$ OF A SUPPLY SYSTEM AND CONTROL THE AUTOMATIC CONNECTION AND DISCONNECTION OF COMPENSATION CAPACITORS ACCORDING TO DESIRED $\cos \varphi$. MICROPROCESSOR CONTROLLED POWER FACTOR CONTROLLER WITH 1-PHASE MEASUREMENT SYSTEM.

FEATURES

- START MENU FOR EASY COMMISSIONING
- AUTOMATIC DETECTION AND CORRECTION OF THE PHASE OF CURRENT AND VOLTAGE CONNECTION
- FULLY-AUTOMATIC C/K-VALUE SETTING, SELF ADAPTING, CONNECTION OF DIFFERENT CAPACITOR STEP SIZES POSSIBLE
- AUTOMATIC DETECTION AND USAGE OF THE OPTIMUM CAPACITOR STEP
- SWITCHING PROGRAMS: BEST FIT, LIFO, MANUAL MODE, COMBIFILTER, PROGRESSIVE
- CAPABLE FOR 4-QUADRANT OPERATION
- 1-PHASE MEASUREMENT SYSTEM ALSO SUITABLE FOR NON-SINUSOIDAL CURRENTS AND VOLTAGES
- SUPPLY VOLTAGE TAKEN FROM MEASURING VOLTAGE
- VOLTAGE MEASURING: 90 - 550 V, 45 - 65 HZ
- CURRENT MEASURING: 15 mA - 5 A, SUITABLE FOR CT X/1 A UND X/5 A
- CONNECTION WITH PLUGABLE SCREW TERMINALS
- LCD WITH BACKLIT
- DISPLAY OF ALL IMPORTANT GRID AND SYSTEM PARAMETERS
- DISPLAY OF THD U AND VOLTAGE HARMONICS FROM 3RD TO 15TH ORDER
- INPUT FOR TEMPERATURE SENSOR OR THERMOSTATE (N/O) (THIS INPUT CAN BE USED TO SWITCH-OVER THE TARIF BY N/O CONTACT)
- ALARM RELAY WITH VOLTFREE N/O CONTACT (OPERATED AT NORMAL FUNCTION)
- TTL-INTERFACE ON REAR
- INSTRUMENT CASING FOR CUTOUT 144 X 144 mm, DEPTH 49 mm
- PROTECTION CLASS IP20 (CASING), IP50 (FRONT)

POWER FACTOR CONTROL RELAY

PFC-CX

CONNECTION

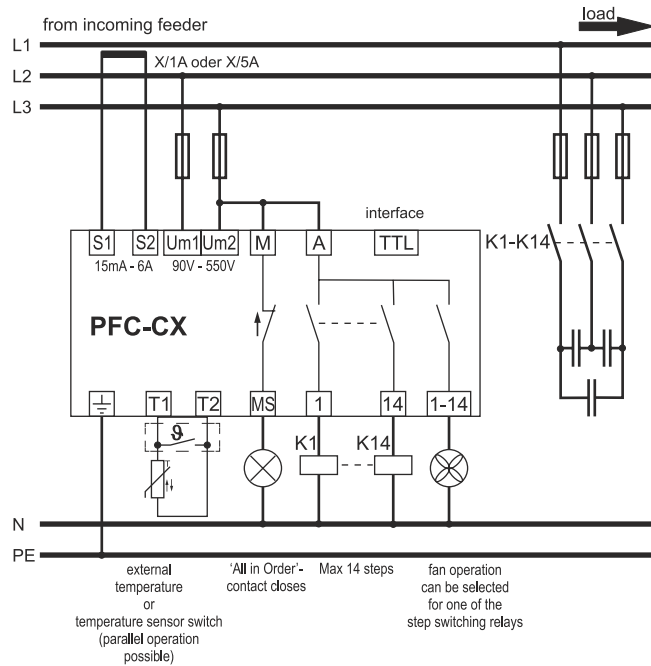

DIMENSIONS

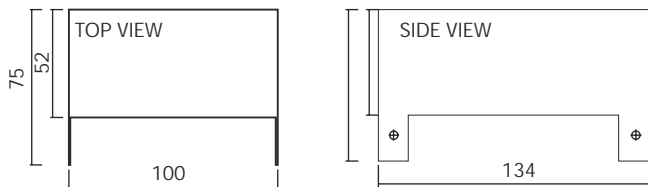

HARMONIC FILTER REACTORS

3UI



ELECTRICAL POWER SUPPLY TO INDUSTRIAL NETWORKS IS NOWADAYS POLLUTED TO THE SAME DEGREE AS THE AIR WE BREATHE IN THE MAJOR CONURBATIONS AND LARGE CITIES OF OUR PLANET. THIS IS DUE TO INCREASING APPLICATION OF NON-LINEAR LOADS, SUCH AS VARIABLE SPEED DRIVES, FREQUENCY CONVERTERS AND RECTIFIERS, BUT ALSO THE ASTRONOMICALLY HIGH NUMBER OF ELECTRICAL ENERGY CONSUMERS. THE OUTCOME IS UNUSUALLY HIGH LEVELS OF HARMONIC DISTORTION, NOT ONLY RESULTING IN UNNECESSARY LOSSES FROM TRANSMISSION LINES, BUT ALSO IN NON-CALCULABLE RESONANCES BETWEEN NETWORK INDUCTANCES AND POWER FACTOR CORRECTION CAPACITORS.

THIS WAS PREVIOUSLY NOT A MAJOR PROBLEM, BECAUSE THE DESIGN OF CAPACITORS FOR POWER FACTOR CORRECTION (MIXED DIELECTRIC AND LIQUID IMPREGNATION CONTAINING PCBS) MEANT THAT SUCH CAPACITORS WERE RELATIVELY INSENSITIVE TO LINE DISTORTION. FOLLOWING THE WORLDWIDE BANNING OF ELECTRICAL COMPONENTS CONTAINING PCBS, THIS KIND OF CAPACITOR HAD TO BE REPLACED. OVER THE LAST TWENTY YEARS, CAPACITORS MADE OF METALIZED POLYPROPYLENE FILM HAVE FOUND APPLICATION.

THIS NEW CAPACITOR DESIGN PROVIDES MANY ADVANTAGES, CHIEFLY VERY LOW LOSS DISSIPATION AND SMALL VOLUME COMBINED WITH LOW WEIGHT. HOWEVER, ADVANTAGES OFTEN GO HAND-IN-HAND WITH DISADVANTAGES AND THIS ALSO APPLIES TO METALIZED FILM CAPACITORS: A DISTINCT SENSITIVITY TO HARMONIC DISTORTION, CURRENTLY A FAMILIAR AND INCREASING PROBLEM IN INDUSTRIAL NETWORKS.

SEVERAL PHENOMENA ASSOCIATED WITH THIS PROBLEM CAN PRODUCE SUBSTANTIAL PREMATURE AGING IN FILM CAPACITORS:

- HARMONIC DISTORTION IN EXTENDED NETWORKS INDUCES RESONANCE BETWEEN INDUCTANCES OF THE NETWORK AND POWER CAPACITORS, RESULTING IN EXCESSIVE CAPACITOR HEATING.
- HARMONIC CURRENTS OVER AND ABOVE THE FUNDAMENTAL LOAD RESULT IN VOLTAGE DROPS ACROSS THE CAPACITOR ELEMENTS WHICH MAY EXCEED THE VOLTAGE THE CAPACITOR WAS DESIGNED FOR. THIS CAUSES PARTIAL DISCHARGE AND RESULTS IN EXTREME SELF-HEALING EVENTS WITHIN THE CAPACITOR ELEMENTS, LIABLE TO SHORTEN CAPACITOR LIFE CONSIDERABLY.
- EXCESSIVE HARMONIC CURRENTS CAN OVERLOAD THE INTERNAL CONNECTIONS BETWEEN THE CABLES AND CAPACITOR FILM, CAUSING THE ARC-SPRAYED ZINC LAYER TO BE STRIPPED OFF FROM THE SURFACE OF THE CAPACITOR COIL.

HARMONIC FILTER REACTORS

3UI

DESIGN CRITERIA

SINCE IT IS IMPOSSIBLE TO PREDICT CONDITIONS PREVAILING IN THE NETWORK WHERE THE REACTOR WILL DO ITS JOB, ALL REACTORS HAVE TO BE DESIGNED FOR A DEFINED WORST-CASE SCENARIO, MEETING ALL TOLERANCES LAID DOWN BY THE INTERNATIONAL STANDARD IEC 60076. IN THE ABSENCE OF AN APPROPRIATE STANDARD RELATING TO NETWORK QUALITY, THIS WORST-CASE SCENARIO HAD TO BE AGREED BETWEEN LEADING POWER FACTOR CAPACITOR SUPPLIERS. THESE ARE THE DESIGN CRITERIA OF PROVEN RELIABILITY OVER A PERIOD OF MANY YEARS:

- TOLERANCE FOR INDUCTANCE FUNDAMENTAL CURRENT I_1 - 2 % ... + 3 % OF L_N
- ASSUMED HARMONIC VOLTAGE DISTORTION $1.06 \times I_{CN}$ OR $1.10 \times I_{CN}$ (FOR 6% OR 10 % OVERVOLTAGE RESPECTIVELY)
- THERMAL CURRENT I_{th} UH3= 0,5 %; UH5 = UH7 = 5,0 %; BASED ON U_N
- LIMIT OF CORE LINEARITY I_{Lin} $1.05 \times I_{rms}$ (RELATIVE TO WORST-CASE TOLERANCES AND CAPACITOR AGING)
 $1.20 \times I_1 \dots 7$ (RELATIVE TO SWITCHING PROCEDURES AT FULL HARMONIC LOAD)
- ASSUMED AMBIENT TEMPERATURE 40°C

THESE DESIGN PARAMETERS REMAIN UNCHANGED FOR MEDIUM-VOLTAGE REACTORS.

AGAINST A BACKGROUND OF DETERIORATING NETWORK QUALITY, STANDARDS HAVE NOW BEEN LAUNCHED, MAKING CORRESPONDING ADJUSTMENTS TO THE 3UI REACTORS DESIGN FOR LOW VOLTAGE REACTORS NECESSARY AS FOLLOWS:

- DESIGN THREE-PHASE, IRON-CORE, POLYGAP® CORE CONSTRUCTION
- ENCLOSURE IP00 FOR INDOOR USE
- COOLING AIR COOLED, AN
- LAY-OUT ACC. TO IEC 76 AND 289
- TOLERANCES OF THE INDUCTANCES -2 %...+3% OF L_N
- FUNDAMENTAL CURRENT $1,06 I_{CN}$
- HARMONIC LOAD STANDARD VALUES
(VH3=0.5 %, VH5= 5.0 %, VH7= 5.0 % BASED ON U_n)
- LIMIT OF LINEARITY $L(I_{Lin})^3 0.95 L_N$
- INSULATION LEVEL LI / AC -- / 3.0 kV ACC. TO IEC 76-3
- IMPREGNATION COMPLETED UNIT IMPREGNATED UNDER VACUUM AND OVER-PRESSURE IN IMPREGNATION, RESIN ACC. TO TEMPERATURE CLASS H
- WINDINGS COPPER WIRE OR ALUMINIUM BAND WITH COPPER BAR TERMINALS
- TEMPERATURE SENSOR TEMPERATURE SWITCH NORMALLY CLOSED (TNC180) POSITIONED IN MIDDLE COIL
- EARTHING ONE FIXATION HOLE IS SIMULTANEOUS EARTHING

HARMONIC FILTER REACTORS

3UI

TECHNICAL DATA

HARMONIC FILTER REACTORS 400 V

Item	ph	TYPE OF CORE	U _n (V)	f _n (Hz)	p (%)	Nc (kVar)	L _N (mH)	I _{rms} (A)	I _{lin} (A)	Nv (I _{rms}) (A)
1	3	3UI60/30	400	50	5.67 (210 Hz)	1.5	3 x 20.409	2.6	4	30
2	3	3UI75/25	400	50	5.67 (210 Hz)	2.5	3 x 12.245	4.4	7	30
3	3	3UI75/40	400	50	5.67 (210 Hz)	5	3 x 6.123	8.8	15	50
4	3	3UI90/50	400	50	5.67 (210 Hz)	7.5	3 x 4.082	13.2	23	70
5	3	3UI114/62V	400	50	5.67 (210 Hz)	10	3 x 3.061	17.5	31	90
6	3	3UI114/62V	400	50	5.67 (210 Hz)	12.5	3 x 2.449	21.9	39	110
7	3	3UI114/62V	400	50	5.67 (210 Hz)	15	3 x 2.041	26.3	47	130
8	3	3UI114/62	400	50	5.67 (210 Hz)	20	3 x 1.531	35.1	63	150
9	3	3UI114/62	400	50	5.67 (210 Hz)	25	3 x 1.225	43.9	79	180
10	3	3UI132/72V	400	50	5.67 (210 Hz)	30	3 x 1.020	52.6	95	190
11	3	3UI132/72	400	50	5.67 (210 Hz)	40	3 x 0.765	70.2	127	260
12	3	3UI132/72	400	50	5.67 (210 Hz)	50	3 x 0.612	87.7	159	280
13	3	3UI60/30	400	50	7 (189 Hz)	1.5	3 x 25.556	2.4	4	20
14	3	3UI75/25	400	50	7 (189 Hz)	2.5	3 x 15.334	4	6	30
15	3	3UI75/40	400	50	7 (189 Hz)	5	3 x 7.667	8	13	50
16	3	3UI90/30	400	50	7 (189 Hz)	7.5	3 x 5.111	12.1	20	70
17	3	3UI90/50	400	50	7 (189 Hz)	10	3 x 3.833	16.1	26	70
18	3	3UI114/62V	400	50	7 (189 Hz)	12.5	3 x 3.067	20.1	33	80
19	3	3UI114/62V	400	50	7 (189 Hz)	15	3 x 2.556	24.1	40	90
20	3	3UI114/62	400	50	7 (189 Hz)	20	3 x 1.917	32.1	53	140
21	3	3UI114/62	400	50	7 (189 Hz)	25	3 x 1.533	40.2	66	170
22	3	3UI114/62	400	50	7 (189 Hz)	30	3 x 1.278	48.2	80	190
23	3	3UI120/75	400	50	7 (189 Hz)	40	3 x 0.958	64.3	106	220
24	3	3UI132/72	400	50	7 (189 Hz)	50	3 x 0.767	80.3	133	240
25	3	3UI75/25	400	50	14 (134 Hz)	1.5	3 x 55.272	2.3	3	30
26	3	3UI75/40	400	50	14 (134 Hz)	2.5	3 x 33.163	3.8	5	40
27	3	3UI90/30	400	50	14 (134 Hz)	5	3 x 16.582	7.7	10	80
28	3	3UI90/50	400	50	14 (134 Hz)	7.5	3 x 11.054	11.5	16	80
29	3	3UI132/72V	400	50	14 (134 Hz)	10	3 x 8.291	15.4	21	80
30	3	3UI132/72V	400	50	14 (134 Hz)	12.5	3 x 6.633	19.2	27	90
31	3	3UI132/72V	400	50	14 (134 Hz)	15	3 x 5.527	23.1	32	110
32	3	3UI132/72V	400	50	14 (134 Hz)	20	3 x 4.145	30.8	43	150
33	3	3UI132/72	400	50	14 (134 Hz)	25	3 x 3.316	38.5	53	190
34	3	3UI150/75V	400	50	14 (134 Hz)	30	3 x 2.764	46.2	64	210
35	3	3UI150/90V	400	50	14 (134 Hz)	40	3 x 2.073	61.5	86	270
36	3	3UI150/90V	400	50	14 (134 Hz)	50	3 x 1.658	76.9	107	290

HARMONIC FILTER REACTORS

3UI

PRELIMINARY DRAWINGS AND APPROXIMATE DIMENSIONS

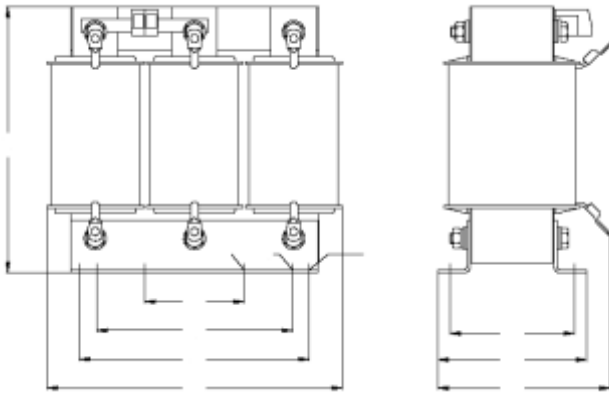

	A	B	C	D	E	F	G	H	d1	d2	d3
	[mm]	[mm]	[mm]	[mm]	[mm]	[mm]	[mm]	[mm]	[mm]	[mm]	[mm]
3UI60/30	120	110	80	90	-	-	49	64	4,8	-	-
3UI75/25	150	135	90	113	-	50	50	64	6	-	6
3UI75/40	150	135	105	113	-	50	65	84	6	-	6
3UI90/30	180	160	100	136	100	60	57	76	7	9	9
3UI90/50	180	160	120	136	100	60	77	96	7	9	9

PRELIMINARY DRAWINGS AND APPROXIMATE DIMENSIONS

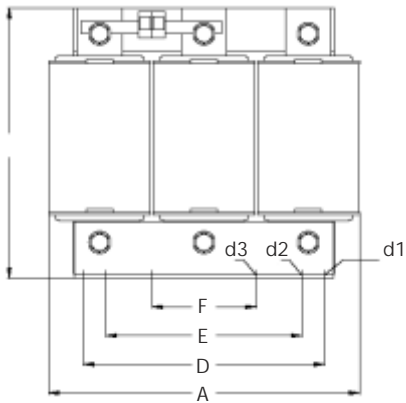

	A	B	C	D	E	F	G	H	d1	d2	d3
	[mm]	[mm]	[mm]	[mm]	[mm]	[mm]	[mm]	[mm]	[mm]	[mm]	[mm]
3UI114/62V	230	160	135	176	150	76	95	114	7	11	11
3UI114/62	230	205	135	176	150	76	95	114	7	11	11
3UI120/75	240	210	155	185	150	80	107	127	9	11	11
3UI132/72V	260	185	150	200	150	88	102	132	10	11	11
3UI132/72	260	240	150	200	150	88	102	132	10	11	11
3UI150/75V	300	235	165	224	150	100	119	147	10	11	11

HARMONIC FILTER REACTORS

3UI

Preliminary drawings and approximate dimensions

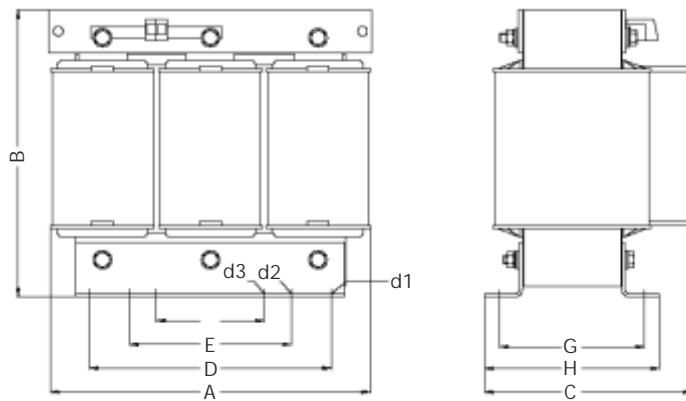

	A	B	C	D	E	F	G	H	d1	d2	d3
	[mm]	[mm]	[mm]	[mm]	[mm]	[mm]	[mm]	[mm]	[mm]	[mm]	[mm]
3UI150/90V	300	235	180	224	150	100	134	162	10	11	11

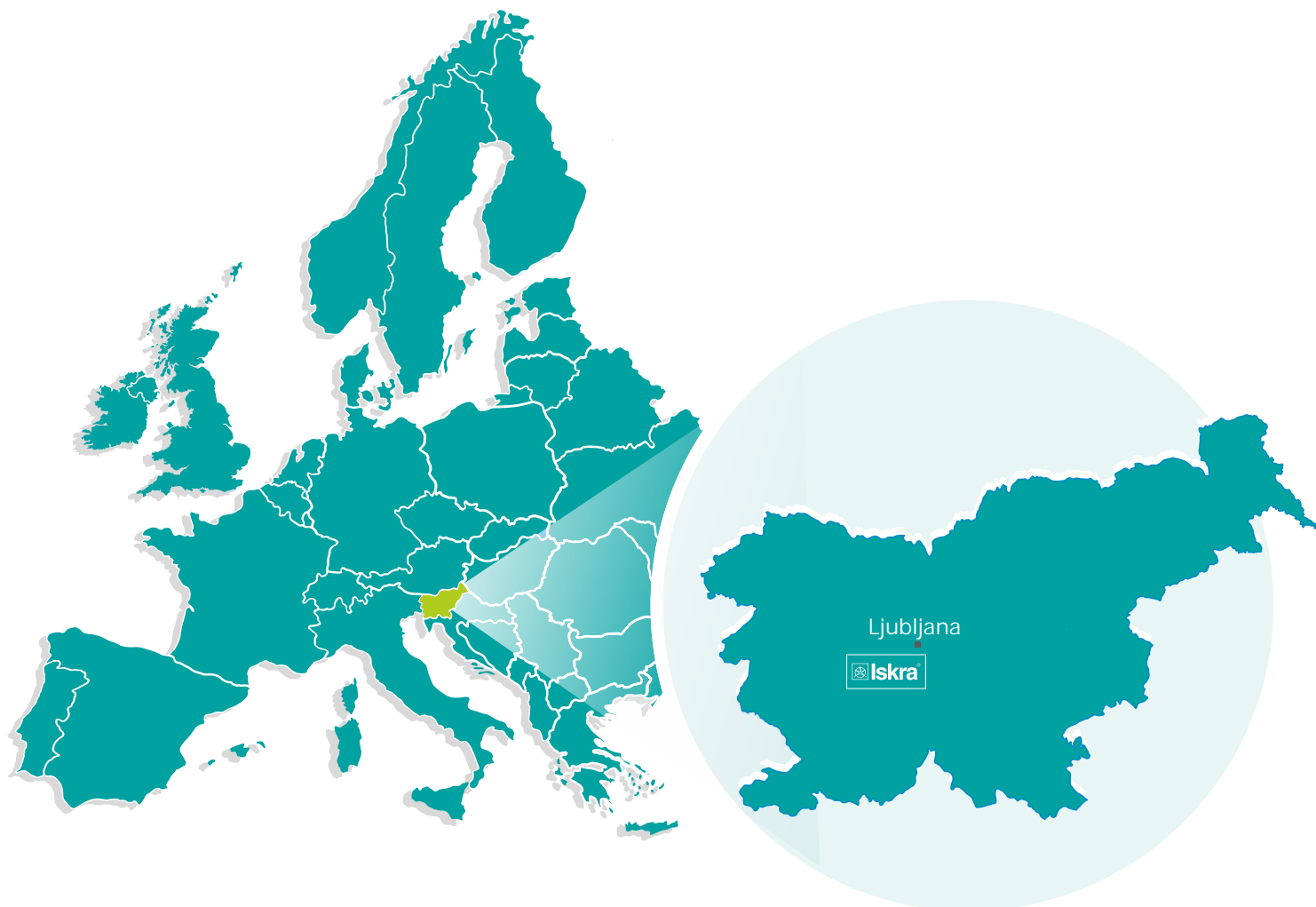

Headquarter

Stegne 21
SI-1000 , Ljubljana
Phone: + 386 1 513 10 00

BU Kondenzatorji

Vajdova ulica 71
SI-8333 , Semi
Phone: +386 7 38 49 200

BU MIS

Ljubljanska c. 24a
SI-4000 , Kranj
Phone: +386 4 237 21 12

PE Baterije in potenciometri

Šentvid pri St. ni 108
SI-1296 , Šentvid pri St. ni
Phone: +386 1 780 08 00

PE Galvanotehnika

Glinek 5
SI-1291 , Skofljica
Phone: +386 1 366 80 50

Iskra IP, d.o.o.

Vajdova ulica 71
SI-8333 , Semi
Phone: +386 7 384 94 54

Iskra Lotri , d.o.o.

Oto e 5a
SI-4244 , Podnart
Phone: +386 4 535 91 68

Iskra ODM, d.o.o.

Oto e 5a
4244 , Podnart
Phone: +386 4 237 21 96

Iskra STIK, d.o.o.

Ljubljanska cesta 24a
SI-4000 , Kranj
Phone: +386 4 237 22 33

Iskra Tela L, d.o.o.

Omladinska 66
78250 , Laktaši
Phone: +387 51 535 890

Iskra Sistemi - M dooel

Ul, Dame Gruev br. 16/5 kat
1000 , Skopje
Phone: +389 75 444 498

Iskra Commerce, d.o.o.

Hadži Nikole Živkovi a br. 2
11000 , Beograd
Phone: +381 11 328 10 41

Iskra Hong Kong Ltd.

33 Canton Road, T.S.T.
1705 , China HK City
Phone: +852 273 00 917
+852 273 01 020

Iskra INDIA Pvt Ltd.

3 shree Ganesh Glory
Appartment Nakshtra
Colony Near Akashwani
Kendra, Nashik
Phone: +91 253 2346161
+91 909 6900893



ISKRA, d.o.o.
Stegne 21
SI-1000 Ljubljana, Slovenia

Phone: +386 (0) 1 513 10 00
www.iskra.eu