

Three Phase Solid State Relays **& Their Application in Three Phase Heating Circuits**

By Paul Bachman, Fellow Engineer,
Dr. Oscar Montero, R&D Manager, and
Doug Sherman, FSAE Manager,
Crydom, Inc.

ABSTRACT

Three Phase Solid State Relays (SSRs) have been available since shortly after the introduction of Single Phase SSRs in 1970. The first of these relays were nothing more than 3 individual SSRs with a common input connection packaged in a single housing. This basic design concept remains, for the most part, unchanged today. However, even though the function of single phase and three phase relays are quite similar, their applications can vary significantly. This is primarily due to the characteristics of three phase power circuits and the attributes / demands of three phase loads.

The proper selection and application of three phase SSRs for Heater control applications depends not only upon a comprehensive understanding of three phase SSRs, but also of the three phase power system and typical loads as well. This paper includes a summary review of three phase power systems, the characteristics of common three phase heating loads, and a comprehensive discussion of three phase SSRs and their application relative to such loads.

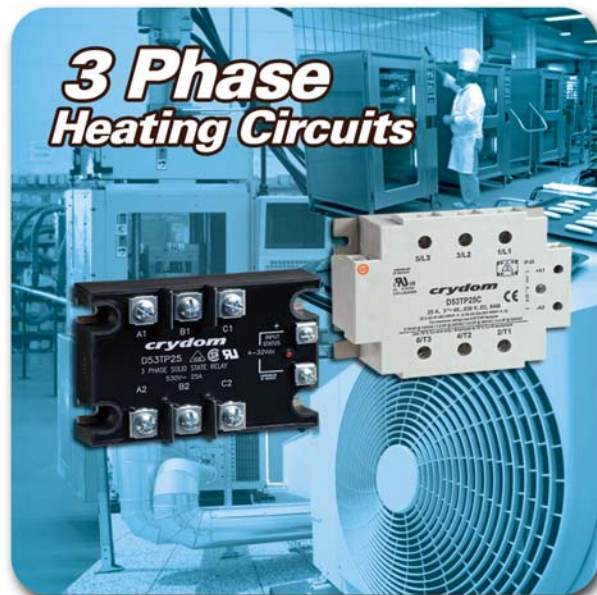



INTRODUCTION

Solid State Relays are used in a wide variety of electrical load-switching applications, including Professional Cooking Equipment, Plastics Machinery, Packaging Machinery, Lighting Systems, Medical Equipment, Laboratory Ovens, Beverage Dispensing Equipment, HVAC&R systems, and many other industrial or commercial applications. However, for the purpose of understanding these applications relative to the use of SSRs for their control, the vast majority of loads can be grouped into two primary categories: heating and motion control. Obviously this is not an all-inclusive grouping as there are other applications outside of the scope of these two categories such as lighting and power distribution systems. However, a majority of Design Engineers specifying SSRs apply them to one of these two general types of three phase loads. The focus here is on Heating loads while a companion paper focuses on Motor loads.

While every application is different and requires its own scrutiny, focusing on these two main categories allows us to generalize about the characteristics of the applications and the subsequent requirements placed upon the SSRs used to perform the switching functions for each. Moreover, limiting the focus to higher-power systems utilizing three phase networks to energize the load(s) covers some of the most demanding commercial and industrial applications where SSRs are used today.

THREE PHASE SSRs DEFINED & DESCRIBED

As previously mentioned above, a three phase SSR is essentially 3 individual single phase SSRs packaged in a single housing with a common input so that each SSR is energized simultaneously. In fact, it is not uncommon for engineers to use 3 individual SSRs to switch power to a three phase load. This is usually done out of preference or where a pre-packaged three phase SSR is not suitable for one reason or another. However, the more common and simplistic approach is to use a three phase SSR to provide the switching function. This simplifies wiring and usually reduces overall space requirements within the panel.

The main attributes of SSRs, whether single or three phase are: contactless turn on and turn off which means no arcing, contact bounce or acoustic noise; high speed switching; long life expectancy; low input control power requirements; zero current turn off which substantially minimizes electrical transients especially when switching inductive loads; and zero voltage turn on which can minimize turn current surges and their resulting transients.

Three phase SSRs are intended to control three phase AC loads, which might otherwise be switched by Electromechanical Relays, Contactors or three phase Mercury Relays or Contactors. For three phase resistive heating applications, zero-crossing three phase SSRs are commonly used. These versions will switch power to the load at the zero-voltage crossing point of each phase in order to minimize inrush currents. Random turn-on SSRs are recommended



for switching inductive loads, such as motors, compressors, or transformers where it is desirable to switch on 3 phases on at exactly the same moment. All AC output SSRs (excepting special versions built with FETs or IGBTs) turn off at zero current irrespective of whether they are zero voltage or random turn-on SSRs, and thus reduce transients caused by opening a load with a magnetic field that collapses resulting in transients.

Considerations when incorporating SSRs in three phase applications include: thermal power dissipation in the SSR due to losses in the output power semiconductors which often requires the use of external heat sinks to maintain allowed operating temperature; electrical transients carried on the power lines or created by switching reactive loads that may require additional transient protection for the SSR; and selection of zero voltage or non-zero voltage turn on depending upon load type.

THREE PHASE POWER SYSTEMS

Three phase electric power is the most common method for distributing electric power worldwide. **Figure 1** depicts three phase power as provided by three voltage waveforms for three conductors carrying alternating current at the same frequency but with a shift of 120° between any two of the three phases (instantaneous peak values at different times). Three phase power is typically used to power large motors or other high-power loads and offers several advantages over equivalent single-phase or two-phase systems including:

- Three phase power provides the most consistent supply of current and therefore power. There is always at least 2 phases delivering power to the load where as single phase systems have zero power delivered for a short time each half cycle.
- Three phase systems tend to be more economical as they use less conductor material to transmit power than single or two-phase systems providing the same power level.
- Neutral conductors can use less material or be eliminated completely as the phase currents cancel out one another in a balanced load. In this circumstance where the neutral is eliminated it is also possible to control the load by switching only 2 of the 3 phases which offers further advantages by reducing the number of relays or contacts required.
- Power transfer is constant into a linear and balanced load, which helps reduce vibration in three phase motors compared to single phase motors of equivalent HP.
- Three phase systems produce a magnetic field rotating in one direction, which helps simplify motor design and offers the ability to easily reverse a motor's direction of rotation by swapping two of the three phases.

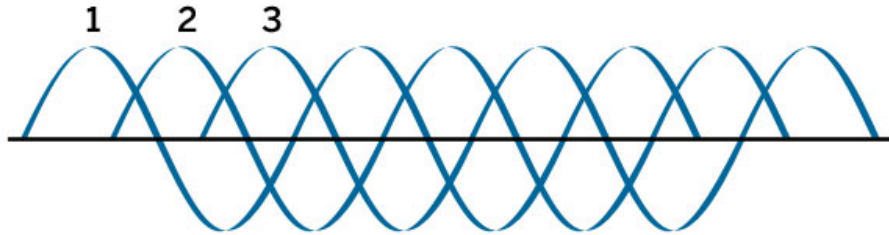

Fig 1 – three phase Sine Waveform

THREE PHASE RESISTIVE HEATING LOADS

Three phase heater loads consist of 3 heating elements which are wired in either a delta configuration (three heating elements connected end-to-end) or in a wye configuration (three heating elements all connected to a common point). **Figure 2** illustrates both types of circuits. The heating elements themselves are typically made with Nickel Chrome wire which is wound into spiral and then inserted into a metal sheath with Magnesium Oxide acting as a dielectric. The diameter and length of the wire determines its resistance and therefore the power rating of the heater. NiCr wire has the advantage of a very low thermal coefficient of resistance, meaning that its hot and cold resistance are very nearly the same, thereby minimizing any cold temperature inrush currents.

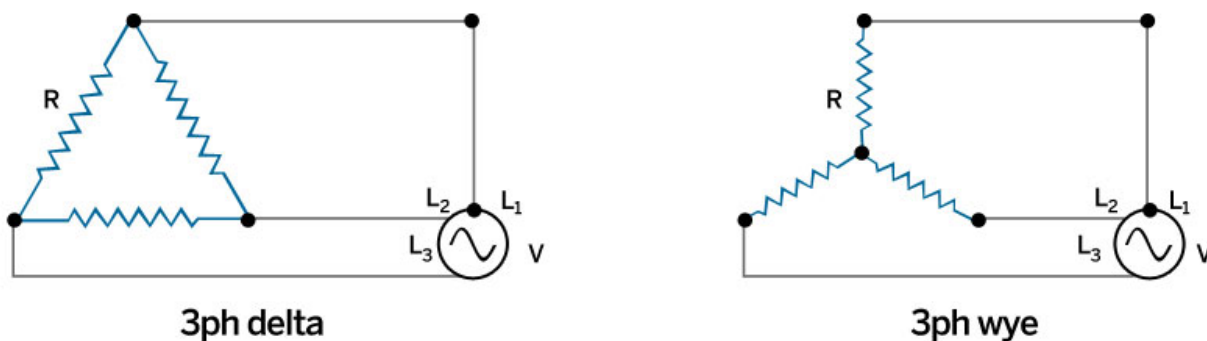

Figure 2 - three phase "Delta" and "Wye" connected Loads.



Three phase heaters are generally rated as an assembly which is the combined wattage of the individual elements. To operate the heater, each phase line has to be controlled by a switch, relay or contactor. To select an appropriately rated control including an SSR, the heater's rated wattage and operational voltage needs to be known. With this information, the line currents that will be controlled can be determined as shown below.

For three phase heating systems, the power developed in a balanced three phase heater is:

$$P = \sqrt{3} \times V_L \times I_L \quad (1)$$

Where P is power, V_L is the line voltage & I_L is the line current

Therefore the line current per phase in a three phase heater load would be calculated as:

$$I_L = P / (\sqrt{3} \times V_L) \quad (2)$$

For reference, the power in watts developed in a single phase resistive heating element is the product of the voltage applied to the element and the resulting current through it:

$$P = V_L \times I_L \quad (3)$$

Therefore the line current through an SSR that is controlling a single phase heating element would be:

$$I_L = P / V_L \quad (4)$$

Comparing formulas (2) and (4) above for calculating line current per phase, assuming equal single and three phase heater power ratings, shows that the line current per phase in the three phase system will be lower than for the single phase system: $(1/\sqrt{3}) \times I_L$ single phase or approximately 58% of the single phase current. *Note: each leg of the three phase system carries that same amount of line current.*

Example Line Current Calculation for a Three Phase Heater

In a delta configured heater load the total wattage is equal to the sum of the wattage of the three individual heating elements. Therefore, the total heater wattage of three individual 480VAC, 5kW elements connected in a delta configuration would be 15kW. Line current would then be calculated as follows:

$$I_{line} = \frac{\text{Total Heater Wattage}}{\sqrt{3}(V_{line})}$$

$$I_{line} = \underline{15.000 \text{ Watts}}$$

Crydom Inc.
2320 Paseo de las Americas, Suite 201
San Diego, CA, 92154
Tel: (619) 210-1550
Fax: (619) 710-8544
E-Mail: sales@crydom.com
Web: www.crydom.com



$$(1.73)(480)$$

$$I_{\text{line}} = 18 \text{ Amps}$$

Note: The above calculations are based upon switching the lines “outside” of the delta which is the most common configuration. However, if the SSRs are placed “inside” the delta, then the “phase current” that each SSR sees is calculated as:

$$I_{\text{phase}} = I_{\text{line}} / \sqrt{3} \quad (5)$$

In the above example, the phase current would then be 10.4 amps per SSR, which is a 43% reduction in current verses the phase current.

For wye connected configurations, the total wattage compared to a delta configuration using the same wattage heating elements is:

$$W_{\text{wye}} = \frac{1}{3}W_{\text{delta}} \quad (6)$$

Therefore, total wattage of three 5kW heating elements wired in a wye configuration would be 5kW. However, line current is still calculated in the same manner shown above for delta configurations which is as follows:

$$I_{\text{line}} = \frac{\text{Total Heater Wattage}}{\sqrt{3}(V_{\text{line}})}$$

$$I_{\text{line}} = \frac{5,000 \text{ Watts}}{(1.73)(480)}$$

$$I_{\text{line}} = 6 \text{ Amps}$$

So in these examples for three 5kW/480 VAC heating elements, an SSR capable of handling at least 18 amps per phase would be required for the delta configuration when the SSRs are placed in the lines, or at least 10 amps if placed “inside” the delta, while an SSR capable of handling at least 6 amps per phase would be required for the wye configuration.

Note: Inrush currents for most heaters can generally be ignored due to the characteristics of the heating elements themselves (NiCr), and therefore the relay selection can be made on the basis of the continuous current alone.

Manufacturers of three phase heaters take into account the heater element resistance values to produce the correct amount of power in a delta or wye configuration. Wiring a three phase heater designed for a wye configuration as a delta circuit will result in significantly higher line currents/power and will likely result in damage to the heater and controls.



Selecting SSRs for Three Phase Resistive Load Applications

Resistive heating control is the most common application today for solid state relays. Fortunately, most of these applications are reasonably straight forward with regards to selecting a suitable SSR since they typically don't have the same surge and overload concerns associated with motor loads.

Since three phase applications have 3 AC lines, 3 AC output solid state switches (or channels) are required to control the load. This can be accomplished by using 3 single channel SSRs or with one three phase SSR as discussed previously. In both cases the control or input signals are wired in common so that each switch/channel is activated at the same time.

Note: for three phase delta connected loads or wye connected loads without a neutral connection, it is possible to control just 2 legs of the three phase supply, thus reducing the number of SSR channels (and consequently cost) needed to control the load. The 3rd leg can be hard wired to the heater lead since there is no current path available when the other 2 legs are open. However, local electrical codes and safety agency requirements may or may not permit this configuration and should be considered before adopting this configuration.

Major advantages of using SSRs to control three phase heater loads include:

- All solid state construction eliminates mechanical fatigue within the relay.
- Contact less, arc free silent operation.
- High speed switching allowing very precise temperature control.
- Logic compatible low power input control.
- Zero voltage turn on eliminating surge currents and resulting transients.
- Zero current turn off eliminating transients.
- Extremely long life when compared to mechanical relays or contactors.
- 4000 VAC isolation input to output.

The general process that should be followed to select a suitable Solid State Relay for a three phase resistive load requires the following information:

- Load Power Rating in KW.
- Nominal AC supply voltage.
- Operating ambient temperature for the SSR in the application.
- Wiring configuration if 3 individual single phase heating elements are utilized.

For most resistive loads, it is common practice to assume that the load's power factor ($\text{Cos } \Theta$) =1. It is also prudent to include a 20% safety margin to allow for line, load and operational variances.



In the example cited above for a 15 KW 480 VAC three phase delta connected heater, the line currents were calculated to be 18 amps. The addition of a 20% safety margin results in a suggested SSR rating of 21.6 amps per phase or channel. Single phase SSRs with ratings of 10, 25, 50, 75, 90, 100 and 125 amps are commonly available, while 3 phase SSRs are commonly available with ratings of 10, 25 or 50 amps per channel. Likewise, Dual SSRs with 10, 25 and 50 amps per channel are available. Therefore purely on the basis of output rating alone, any of these types of SSRs with at least a 25 amps per channel rating should be suitable. However, for the final selection, several other parameters must be considered.

The next part of the selection process relates to determining the power dissipation in the SSR(s) and the ambient temperature that will be present in the SSRs mounting area. Once these values are known, the proper output rating for SSRs with integral heat sinks can be made, or for panel mount SSRs, the required heat sink rating can be calculated.

For SSRs with integral heat sinks the selection process is somewhat simpler than for panel mount versions, but in either case, these calculations are necessary to insure that the SSR operates at a safe operating temperature.

Most AC output SSRs will have an average on-state forward voltage drop of between 1.0 and 1.2 volts. The effect of this voltage drop is that 1 to 1.2 watts of energy are generated in the power assembly of the SSR per ampere of conducted load current, which must be dissipated into the surrounding environment. Heat Sinks are the most common means of facilitating this dissipation. The solid state relay may be mounted directly to a heat sink if it is purchased as an accessory component, or it may be integral to the SSR itself.

Using the previous example and assuming an average SSR forward voltage drop of 1.1 volts, the total power dissipation for the SSRs in the three phase circuit would be calculated as follows:

$$P_{SSR} = V_f \times I_L \times 3 \quad (7)$$

$$P_{SSR} = 1.1 \times 21.6 \times 3$$

$$P_{SSR} = 71.3 \text{ watts}$$

Therefore, 71.3 watts will have to be dissipated into the ambient surrounding the SSR regardless of whether the SSR has an integral or external heat sink.

Selecting three phase SSRs with Integral Heat Sinks

Generally speaking, SSRs with integral heat sinks are the easiest to select because most of the thermal calculations have already been considered in its ratings. **Figure 3** is a typical output current rating verses ambient temperature curve for an SSR with integral heat sink. In the

example given above with line current of 21.6 amps per phase or 64.8 amps in total for all three phases, the SSR represented by this diagram will operate within its allowed ratings up to about a 55°C ambient. Should the ambient temperature surrounding the SSR in the application exceed 55°C, a different SSR/heat sink combination with higher rating must be selected.

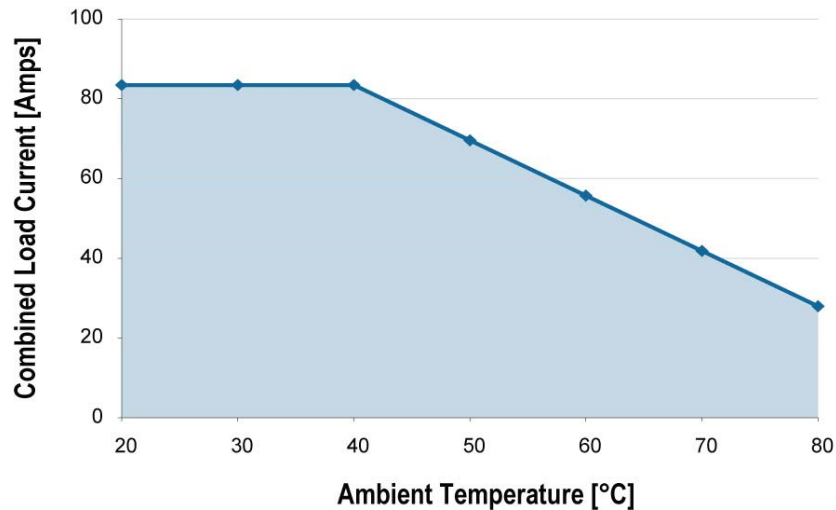

Figure 3 –SSR w/Integral Heat Sink Total Combined Output Current verse Ambient Temperature

Three phase SSRs with integral heat sinks are available in either DIN rail mount or panel mount. In either case, the selection process is the same. The line current has to be determined along with line voltage and operational ambient temperature. Once this is done, it is a fairly simple matter to consult product specifications and review the output current verses ambient temperature charts similar to **Figure 3** above.

In the application example given above of a 15 kW heater with 21.6 amps line current per phase, a three phase SSR rated at least 25 amps per channel must be selected. However, ambient temperature effects whether the heat sink supplied with the SSR is sufficient to allow proper operation in the example applications 40°C ambient.

Utilizing the chart in **Figure 3** as an example, indicates that the SSR represented by the chart would easily operate in a 40°C ambient. However, if the application ambient were higher than 55°C, then an SSR with a higher output rating verses ambient temperature would have be selected (eg: 50 amps/phase SSR).

When selecting a Crydom DIN rail mounted or Panel Mounted SSR with integral heat sink for three phase resistive loads, there are three possible options as shown in **Table 1** below.

- One HS053-D53TP50D panel mounted SSR/Heat Sink assembly
- One CTRD6025 DIN rail mounted SSR
- One HS122-CC4850xxx panel mounted SSR/Heat Sink assembly (33% lower power dissipation as a result of switching only 2 phases)

Note: Above part numbers are examples only. There is a large selection of suitably rated SSRs available from Crydom.

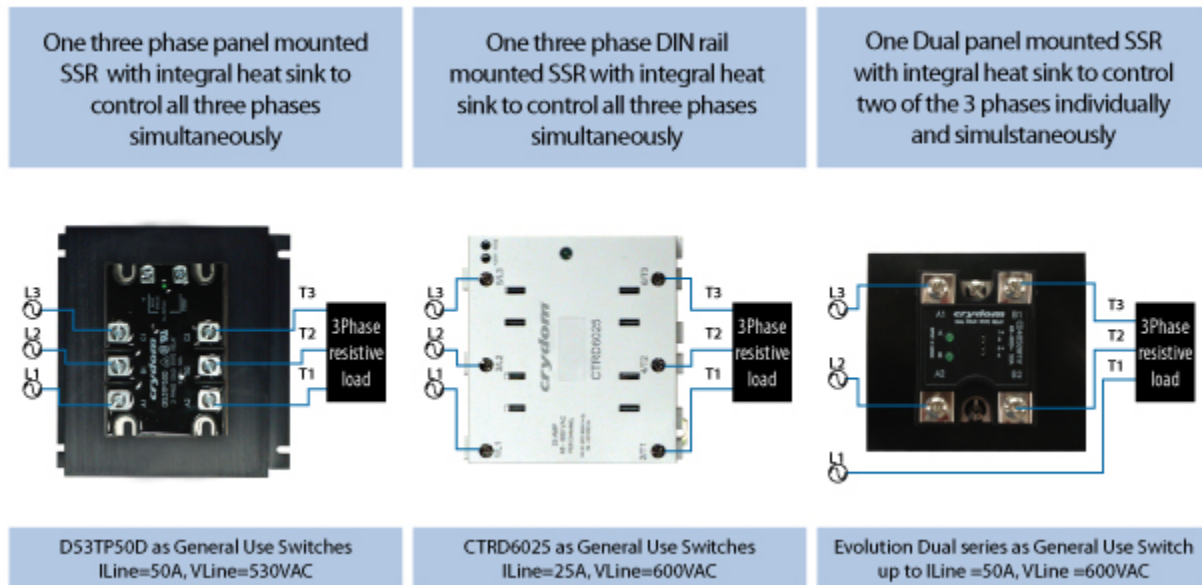

Table 1 - SSR options to implement three phase Resistive load control using DIN rail mounted or panel mounted SSR(s) with integral heat sinks.

Selecting three phase SSRs with Separate External Heat Sinks

In those cases where the SSR(s) and heat sink are separate components, it becomes necessary to determine the required minimum value heat sink rating to maintain a safe operating temperature for the SSR. There are numerous technical papers including Crydom White Papers that describe this process in detail and Crydom also provides a simple Heat Sink Selection Tool on its website for this purpose should additional information be needed.



Generally, most AC output SSRs have a maximum allowed internal operating temperature of 125°C or less. Consequently, the selection of the SSR is determined by the combination of the SSRs power dissipation due to the application load current, operating ambient temperature where the SSR is mounted, and SSR thermal impedance specification.

The minimum heat sink rating ($R_{\Theta HS}$) in degrees C per watt for a given application can be calculated as follows:

$$R_{\Theta HS} = ((125 - T_{amb}) / P_{SSR}) - R_{\Theta SSR} - R_{\Theta TI} \quad (8)$$

Where:

- T_{amb} = the operating ambient temperature in °C
- P_{SSR} = the total power in watts dissipated in the SSR(s) for all 3 phases
- $R_{\Theta SSR}$ = specified SSR thermal impedance °C/W
- $R_{\Theta TI}$ = specified thermal impedance of the thermal interface material placed between the SSR and heat sink $R_{\Theta SSR}$

Note: the thermal interface material is placed between the mounting surface of the SSR and the heat sink to compensate for any surface irregularities that might increase thermal impedance and diminish SSR performance. These materials generally have a thermal impedance of between 0.03 and 0.1 °C/W depending on their composition and thickness.

In the application example given previously of a 15 kW heater with 21.6 amps line current per phase, and a three phase SSR rated at 25 amps per channel operating in a 40 °C ambient with $R_{\Theta SSR}$ of 0.25 °C/W, using formula (8), the minimum heat sink rating would be calculated as follows:

$$R_{\Theta HS} = ((125 - 40 / 71.3) - 0.25 - 0.05$$

$$R_{\Theta HS} = 0.82 \text{ °C/W}$$

Figure 4 is a representative thermal derating curve for a typical three phase panel mounted SSR showing its allowed output rating per phase for a balanced resistive load verses ambient temperature for various heat sink ratings.

Note: SSR output current rating verses ambient temperature charts may be based upon load current per phase, or total combined load current for all 3 phases.

53TP IP20 25A

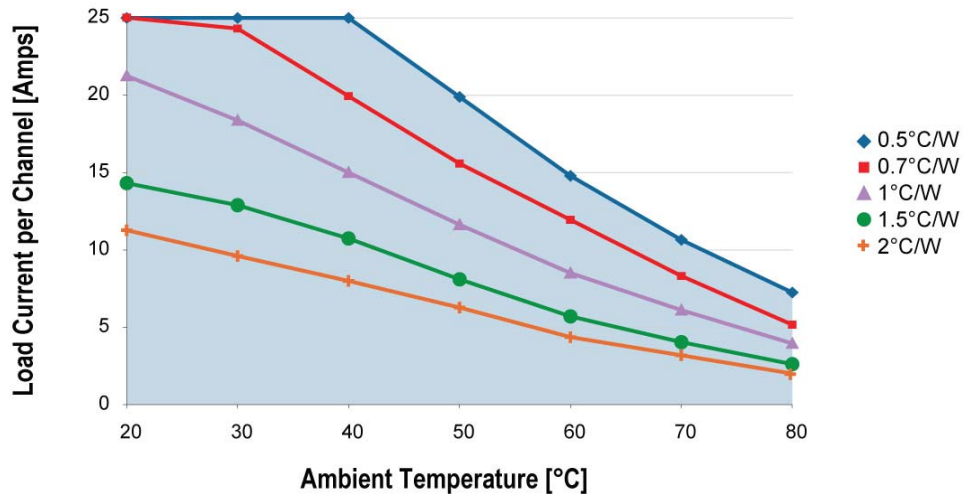

Figure 4 - Output Rating per Phase of a three phase SSR versus Ambient Temperature

In the example calculation and SSR selection above, the calculation determined that a heat sink with at least a 0.82°C/W rating was required. More efficient heat sinks with lower numerical value thermal impedances can of course be utilized with the beneficial effect of lowering SSR operating temperatures, improved reliability and life expectancy.

When selecting a Crydom Panel Mounted SSR for three phase resistive loads there are three possible options as shown in **Table 2** below.

- One D53TP25 or similar three phase SSR mounted on an HS053 heat sink.
- Three CWD4825 or similar single phase SSRs mounted on an HS053 heat sink
- One CD4825xxx or similar Dual SSR mounted on an HS122 heat sink.

Note: Above part numbers are examples only. There is a large selection of suitably rated SSRs available from Crydom.

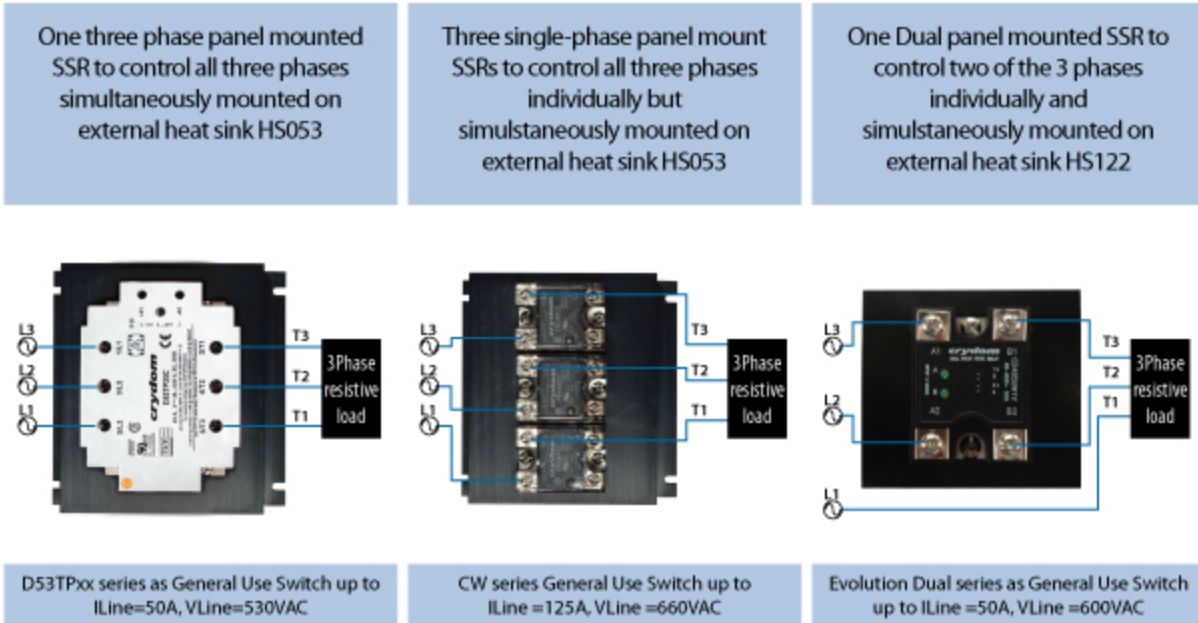

Table 2 - SSR options to implement three phase Resistive load control using panel mounted SSRs with external heat sinks.

For help in selecting the most suitable heat sink once the SSR has been selected, visit the Crydom web site and open the [Heat sink Selection Tool](#). The tool provides an easy means to match heat sinks to SSRs given key parameters of the application as described in this paper.

Safety Agency Standards for Resistive Load Applications

The design and application of high power AC circuits requires certain precautions to insure safe operation. To that end, several local and international standards have been developed to set forth minimum design requirements for such circuits and their components and provide a process for compliance verification to the standards by means of measurement and test.

The following table (3) summarizes the three most common standards that apply to AC resistive load circuits and their component parts (including SSRs):

Standard		Category for SSR	Load / SSR Ratings
Resistive Loads	UL 508. Industrial Control Equipment	AC General Use Switch	$I_{Load} \leq I_{rated}$
	IEC 62314. All or Nothing Electrical Relays	Resistive or slightly Inductive Load, category "LC A"	$I_{Load} \leq I_{rated}$
	IEC 60947-4-3. Low-voltage switchgear and controlgear – Part 4-3: Contactors and motor-starters – AC semiconductor controllers and contactors for non-motor loads	Non-motor loads, category "AC-51"	$I_{Load} \leq I_{rated}$

Table 3- Load current considerations per relevant standards

Although there may well be additional standards that apply to any given application depending upon its specification, intended use or location, generally one or more of the above standards will adequately define the requirements for SSRs utilized in most heating applications.

The main elements of all of these standards pertain to safe operation of the component or system which is established through the imposition of: minimum creepage and clearance distances between conductors, especially between input/control circuits and output/load circuits, minimum dielectric value of insulating materials, integrity of mechanical materials and design, overload endurance and protection, compliance to specification.

Additional information about the above standards is available on the relevant agency web site as well as the Crydom web site.

SUMMARY

Solid State Relays, whether single or three phase, are ideal for the control of three phase resistive heating loads. Proper selection of the SSR for any given application requires knowledge of the applications power rating, wiring configuration, operation voltage and ambient temperature. A variety of SSRs are available for wide range of operating conditions up to 660 VAC and >100 amps per phase, in either Panel or DIN rail mount configurations. Heat sinking is required for the proper operation of SSRs in all applications and technical information on their selection is readily available.

For additional information on Solid State Relays, contact Crydom or visit www.crydom.com.



+++++

Copyright © 2010 Crydom Inc., All rights reserved.

The materials and information on this document are intended for informational purposes only. Materials are copyrighted and are protected by worldwide copyright laws and treaty provisions. They may not be copied, reproduced, modified, published, uploaded, posted, transmitted, or distributed in any way, without Crydom's prior written permission. Crydom does not warrant the accuracy or completeness of the information, text, graphics, links or other items contained within this document. Crydom may make changes to these materials, or to the products described therein, at any time without notice. Crydom makes no commitment to update the Materials.

Crydom Inc.
2320 Paseo de las Americas, Suite 201
San Diego, CA, 92154
Tel: (619) 210-1550
Fax: (619) 710-8544
E-Mail: sales@crydom.com
Web: www.crydom.com