

## HOW TO TEST A SOLID STATE RELAY

There's a very simple way to test an AC Solid State Relay. All you need is a 9 volt battery, a 40-100 Watt light bulb, and an AC source (your wall outlet will be it).

Figure 1 shows the way these devices should be connected. The DC control voltage will be your 9-volt battery with "+" connected to terminal 3 and "-" connected to terminal 4. On the load side (terminals 1 and 2) you will have your light bulb (load) with one terminal connected to one side of the AC source (wall outlet) and the other terminal connected to terminal 2 of the relay (it can be connected to terminal 1 as they are electrically equivalent). The other wire of your AC source should be connected to terminal 1 of the relay to close the circuit.

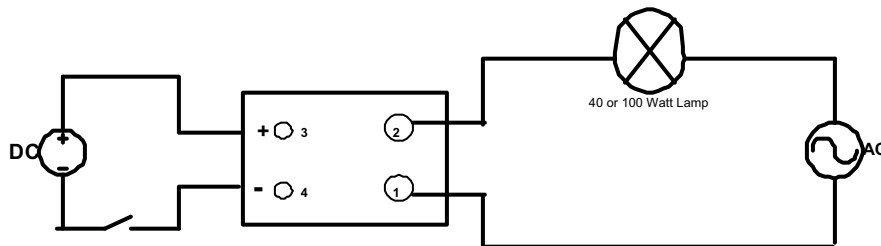

When this is connected, the battery should control when the light is on or off. Applying the 9 volts DC will turn the light on and when you remove the DC voltage, the light bulb should turn-off.

If this does not occur, then, there's a very high probability that you have a damaged relay.

Note: Using a voltmeter to test an SSR is not recommended because the voltage and current needed to trigger the output of an SSR are not present and therefore, producing erroneous readings.

For AC controlled relays the same applies, except that the control voltage will be AC instead of DC. The following figure shows a typical test setup for testing these relays.

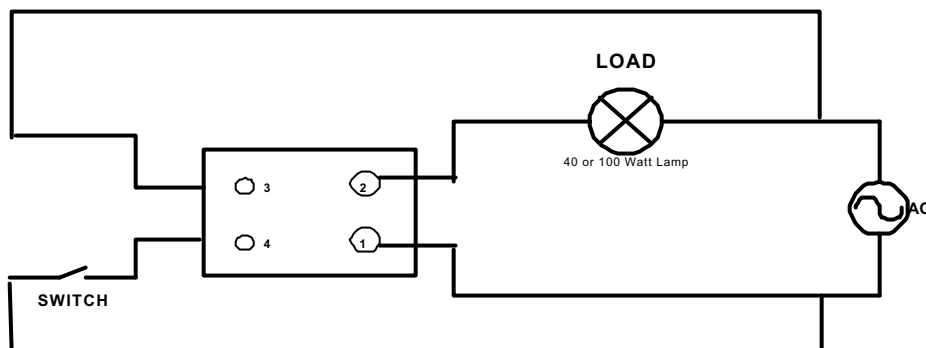

When the switch is open, the light should be off, and with the switch closed, the light should be on. Anything else will indicate a faulty relay.