

## Selecting a Solid State Relay (SSR)

### Selecting a Solid State Relay

This note covers "power" rated AC output solid state relays with current ratings from 1 Arms to 150 Arms. Nominal AC line voltages are 120 Vrms, 240 Vrms, 380 Vrms, 480 Vrms and 600Vrms. These nominal voltage ratings allow a relatively wide range of operating voltage ratings, enabling designers to select a relay with a higher voltage rating than would normally be required.

The use of a solid state relay with a rated voltage higher than the operating line voltage should be considered in harsh electrical environments where high voltage transients can be generated. Normally the maximum transient withstand voltage for a 240 Vrms rated solid state relay is 600 volts peak; for a 380/480Vrms rated unit, it is 1,200 volts peak. So, a 380/480 volt rated relay used on a 120 or 240 Vrms line allows a significant voltage safety factor.

Printed circuit board mount solid state relays can operate at currents from 1Arms to 10/25 Arms. The 10/25 Arms types can be operated at 10 Arms with natural convection cooling and up to 25arms with forced air cooling. Above these current ratings, a panel mount relay should be used with adequate heat sinking (discussed later).

Solid state relays have either a DC or AC control. For DC control the normal voltage range is 3-32 Vdc, but for some families of relays, the DC control voltage is separated into two ranges, 3-15 Vdc and 15-32 Vdc. AC control ranges are 18-36 Vrms, 90-140 Vrms and 90-280 Vrms. All AC control

relays can also be operated on the equivalent DC voltage (18-36 Vdc, 90-140 Vdc and 90-280 Vdc).

Most solid state relays have a normally open output – that is, with no control signal, the relay output is non-conducting. Some specific types of solid state relay have a normally closed output, so that with no control signal the relay output is conducting. Where a normally closed function is required for a DC controlled relay, and the particular relay type that is suitable for the application is not available with a normally closed option, then a simple inverter circuit (Fig 1) can be used.

In some cases a normally open and normally closed solid state relay will be used to provide a change-over function. When a break-before-make function is required, a minimum interval equal to one full cycle of the AC supply frequency (16.67 milliseconds for 60 Hz and 20 milliseconds for 50 Hz) must be provided between the removal of one control signal and the application of the other control signal. If this "dead" period is not provided, especially with inductive loads, both relays may conduct at the same time. This precaution also applies to applications

like AC motor reversers where, if the wrong combination of relays is conducting, a line-to-line short can occur.

When selecting a Solid State Relay, consider:

- Current rating, as a general rule consider a using the relay at no more than 70% of its rated current.
- Printed circuit board or panel mount
- Line voltage
- Electrical environment, (In harsh electrical environments, consider a relay with an line voltage rating above the application line voltage.)
- Control voltage
- Contact form

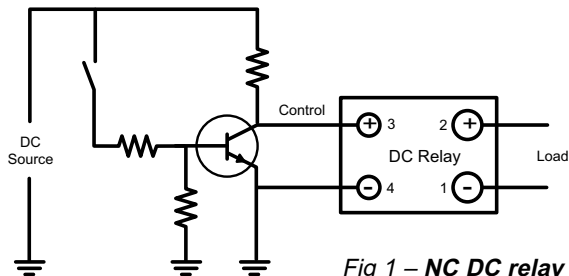

Fig 1 – NC DC relay drive

### How to Connect to Solid State Relays

Electrical connections to a solid state relay can be made in a number of ways. Due to the isolation between input and output and output to baseplate (where relevant) a DC controlled relay can use either a sink or source connection for control and the AC load can be connected to either of the output terminals, with either line or neutral connected to the other terminal. These different connection arrangements are shown in Fig 2. For AC controlled solid state relays, the same principle applies; however, if either side of the AC control signal is common with the load AC supply, precautions are necessary to avoid AC line shorts.

#### Available Agency Approvals

The vast majority of equipment using solid state relays requires approval by various safety agencies. In the United States UL is the preferred agency, CSA in Canada, and VDE (the major German safety agency) in Europe. Although UL is becoming more accepted in Europe, many European users insist on a European agency approval for all components in their equipment. Crydom has more part numbers approved by UL, CSA and VDE than any other solid state relay manufacturer.

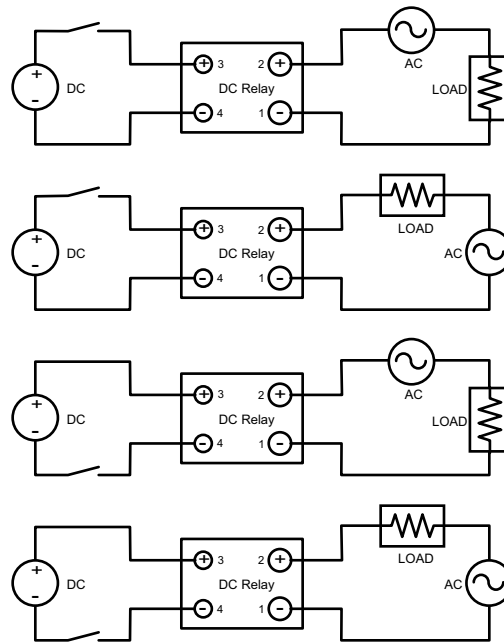

**Fig. 2 - Connecting Solid State Relays**