

**OPERATING MANUAL FOR MODEL CTRCT-2
CURRENT TRIP/REGULATOR WITH CURRENT TRANSFORMER FEEDBACK
CIRCUIT BOARD (Revision C)**

INTRODUCTION

This manual is intended to familiarize the user with the salient features of the circuit board. Typical connection diagrams and a troubleshooting guide are also provided.

REFERENCES

1. E128, Schematic Diagram, "General Purpose 3Ø Firing Circuit"
2. E168, Schematic Diagram, "1Ø 4-SCR Bipolar Firing Circuit"
3. E371, Schematic Diagram, "Current Trip/Regulator, CT Feedback PWA"
4. R054, Operations Manual, "FCOG6100 6-SCR General Purpose Firing Board"
5. R187, Operations Manual, "FCRO4100 4-SCR 1Ø Firing Circuit"
6. Bourbeau, F.J., "Phase Control Thyristor Firing Circuit: Theory and Applications", Power Quality '89, Long Beach, California

PRODUCT DESCRIPTION

APPLICATION

The CTRCT-2 Current Trip/Regulator with Current Transformer (CT) Feedback board operates in conjunction with Enerpro designed firing circuit boards to provide regulated load current. The FCRO4100 4-SCR 1Ø firing circuit is used in 1Ø ac-ac controllers (anti-parallel SCRs) and 1Ø ac-dc converter (e.g., bridge) applications while the FCOG6100 general purpose 3Ø firing circuit is used in the corresponding 3Ø application. The resulting two-board assembly responds to either a voltage or milliamp current signal to provide synchronized gate firing pulses for single phase two and four SCR circuits or three phase three and six SCR circuits while also adjusting the gate firing phase angle to regulate the load current. An over-current trip feature is also provided to shut down the system in the case of a momentary short circuit. The system may be manually reset or may be automatically reset after an adjustable time delay.

Options include a maintained contact run/stop switch and a current limit operating mode rather than the current regulator mode. The application range is also enhanced by the use of additional Enerpro boards. These boards extend the usage to the gating of:

- paralleled SCRs
- four-quadrant converters
- twelve-pulse converters
- sequence reversing controllers¹
- remote operation of SCRs

The CTRCT-2 board adds the following capabilities to our CTRCT-1 board.

- Voltage or Current Regulation with maintained Current Trip capability
- Remote status drivers to indicate a Current Trip or Manual Trip has occurred
- Remote status driver to indicate Current Limit Operation. This indicator is normally on.
- On-board soft-start and soft-stop time adjustment

BOARD MOUNTED CONNECTORS

The CTRCT-2 circuit board is completely connectorized, using AMP Universal Mate-N-Lok™ right angle headers², to simplify maintenance and troubleshooting. Mating plugs and contacts are included with the circuit board and require a U-barrel crimper for proper installation. An overview of each connector pin function is provided below:

J1	Pin	Label	Function
	1	+30	+30Vdc control power from the firing board
	2	SIG HI	Phase angle command signal to the firing board
	3	Stop	Momentarily removing common from this point will inhibit SCR gating.
	4	Reset	Momentarily connecting +12Vdc to this point will enable SCR gating and/or reset over-current trip
	5	+12	+12Vdc control power from the firing board
	6	+12	+12Vdc control power from the firing board
	7	COM	Circuit common
	8	COM	Circuit common

J2	Pin	Label	Function
	1 - 3	from CTs	Current transformer feedback is applied here

¹ 3Ø circuits only.

² Vertical headers are available upon request.

J3	Pin	Label	Function
	1	I_F / E_F	Voltage feedback. This can either be an input (from a customer provided source), or an output to an additional current circuit (close both PP1-7 & PP1-8).
	2	<NOT>I1	Instant Inhibit connection to the firing board
	3	<NOT>I2	Soft Inhibit connection to the firing board
	4	Current Command	The customer supplied current command is applied here
	5	Delay Command	The customer supplied delay command is applied here

J4	Pin	Label	Function
	1	Current Trip	Remote Current Trip Driver. This signal will be pulled low if a current trip occurs.
	2	Current Limit	Remote Current Limit Driver. This signal will be pulled low when the board is in the current limit mode.
	3	Manual Trip	Remote Manual Trip Driver. This signal will be pulled low if the board is manually stopped.
	4	+12	+12Vdc control power
	5	COM	Circuit common
	6	+24	+24Vdc control power

CURRENT FEEDBACK

Three phase CT current is input to J2 pins 1, 2, & 3 on the CTRCT-2. (Single phase CT current can be input on any two pins of J2.) The phasing is unimportant since the ac currents will be converted into a dc equivalent.

A portion of the current in each mains phase appears across the secondary of a CT (e.g., with a 200:5 CT, and one primary turn, 1/40th of the mains current appears on the secondary). This mains current flows into the CTRCT-2 board where it is rectified by a 3Ø bridge consisting of CR1 - CR6. The rectified current is then converted to a voltage signal, I_F , by burden resistor R5. R5 is chosen, as outlined below, so that $I_F = 1.00V$ at full load.

$$\underline{1\text{Ø Circuits:}} R5 = (\text{CT ratio}) \cdot 2 / I_L$$

$$\underline{3\text{Ø Circuits:}} R5 = (\text{CT ratio}) / (1.28 * I_L)$$

where I_L = full load current

Zener diode, CR7, protects the circuit from voltage spikes of more than 15Vdc. The current feedback signal is then input to the current trip circuit and to the current regulator circuit.

CURRENT (VOLTAGE) COMMAND

The current command signal is applied to J3-4 on the CTRCT-2 board. The default value of the current command signal is 0.0 to 5.0Vdc³. Optional dropping resistor, R11, may be installed to convert a milliamp (e.g., 0-10mA) signal to the proper voltage. If an alternate current command voltage level is desired, select R15 so that the maximum voltage at TP9 is 2.5Vdc.

The applied current command signal is attenuated by the SPAN potentiometer, R2, and R15. This attenuated value is then further reduced by a voltage divider formed by RN3-1 and RN4-5 and applied to the non-inverting input of the error amplifier, U1-1. The SPAN potentiometer, R2, is adjusted to provide the desired maximum output current with a maximum current command applied. If no external current command input is desired, close PP1 position 5 to connect approximately 12.0Vdc to this input.

The addition of C5 to the current command circuit will increase the system response to a changing current command signal.

This command signal can function as either the current command signal or the voltage command signal. Which function it performs is determined by the setting of PP1 positions 7 & 8. If PP1-7 is closed and an external voltage feedback signal is applied to J3-1 then the board will operate as a voltage regulator while maintaining current trip capability. If PP1-8 is closed, the board will operate as a current regulator since the current feedback developed across R5 will be connected to the regulator.

DELAY COMMAND INPUT

The delay command input is applied to J3-5 on the CTRCT-2 board. The default value of the current command signal is 0.0 to 5.0Vdc. Optional dropping resistor, R12, may be installed to convert a milliamp (e.g., 0-10mA) signal to the proper voltage. If no external delay command input is desired, close PP1 position 6 to connect approximately 11.0Vdc to this input.

The delay command input is applied to the non-inverting input of U2-8. This When the delay command is larger than the current error signal the output of U2-8 is high and CR15 is reversed biased. Therefore, there is no affect on the circuit. When the delay command input is smaller than the current error signal, the output of U2-8 goes low and CR15 becomes forward biased. This pulls down the current error signal and causes a reduced delay command output from the board thereby increasing the firing board delay angle.

³ +5Vdc control power is available on either J4-7 on the FCRO4100 1Ø firing board or at J3-7 on the FCOG6100 3Ø firing board.

START/STOP/RESET COMMANDS

Several modes of control are possible for enabling and inhibiting SCR gating and for resetting an over-current trip:

- 1. Start.** Start-up may be engaged either by momentary contact closure (pushbutton) or application of control power (120Vac start) to the firing board. In either case, current is ramped up from zero to the commanded level at a rate which is determined by the soft-start circuit.

In the 120Vac start mode (PP1-3 = Closed, PP1-4 = Open) the application of control power causes a momentary logic 1 on the reset as C3 conducts from the 12Vdc supply through RN1-5 and RN2-5&7. This momentary logic 1 ensures that the latches are reset and allows the gate firing board to be enabled.

In the pushbutton start mode (PP1-3 = Open, PP1-4 = Closed) the application of control power causes a momentary logic 1 on the U3-9 set pin as C3 conducts from the 12Vdc supply through RN2-1 and the external common connection at J1-3, if present. This ensures that the latches are set and that the gate firing board is inhibited.

- 2. Reset.** An over-current trip diagnostic shutdown may be reset either automatically or manually, by pushbutton.

Manual reset is accomplished by momentarily closing a contact between the 12Vdc supply and the reset pin at J1-4. Momentarily connecting 12Vdc to the reset pin causes the reset on U3-9 to be pulled high through RN2-5&7. In addition, pulling the U3-9 reset high forward biases CR19 and pulls the reset of U3-2 high. This resets the latches, assuming the set pins are low, and enables the gate firing board.

- 3. Stop.** Manual shutdown is initiated by opening a contact between circuit common and the stop pin at J1-3.

The shutdown mode initiated by a manual shutdown or an over-current trip diagnostic shutdown is selected using PP1. Instant-off (PP1-1 = Open, PP1-2 = Closed) will immediately inhibit SCR gating while the soft-off mode (PP1-1 = Closed, PP1-2 = Open) will ramp the current to zero before inhibiting.

Summary of PP1 Settings

NO.	FUNCTION	PLUG POSITION (X = Closed, O = Open)							
		1	2	3	4	5	6	7	8
1	SOFT-ON, INSTANT-OFF	X	O	-	-	-	-	-	-
2	SOFT-ON, SOFT-OFF	O	X	-	-	-	-	-	-
3	120VAC START	-	-	X	O	-	-	-	-
4	PUSH-BUTTON START	-	-	O	X	-	-	-	-
5	+12V CURRENT COMMAND INPUT	-	-	-	-	X	-	-	-
6	+11V DELAY COMMAND INPUT	-	-	-	-	-	X	-	-
7	VOLTAGE REGULATION	-	-	-	-	-	-	X	O
8	CURRENT REGULATION	-	-	-	-	-	-	O	X

CURRENT TRIP STAGE

Operational Amplifier (OP Amp) U1-14 serves as the current trip comparator. The non-inverting input of U1-14 is connected to I_F via a RC network consisting of RN4-1 and C6. This RC network serves to provide some isolation and filtering of the current feedback signal prior to its application to the comparator. The delay associated with this circuit is approximately 3.3msec. The inverting input of U1-14 is tied to the wiper of the TRIP potentiometer, R3. Adjusting R3 between 0 and 100% sets the current trip threshold at 0 to 220% of full load current.

An I_F level greater than the current trip threshold causes a logic 1 to be applied to the Set input of the Over-current Trip Latch, U3-2. This in turn causes the Q output to latch high until the Reset is pulled high. Current then flows through diode CR11 and RN2-9 to raise the inverting input of comparator U1-8 to a level above the non-inverting input of 2.2Vdc. This results in U1-8 being driven to a logic 0 state, which causes the firing board gating to inhibit.

The logic 1 output of U3-2 is also applied to the anode of PD2. This causes current to flow through PD2 and U4-1/2. This action illuminates PD2 and causes the remote over-current connection at J4-1 to be pulled low. If an external indicator is connected between J4-1 and J4-6 it will energize.

The Over-current Trip Latch may be reset either manually or automatically. Automatic reset is enabled by the installation of CR9, CR10, and C2. The delay period before reset is determined by the time constant of R16 and C2 as follows:

$$t = (R16)(C2)(0.205)$$

where t = time in msec, R is in k Ω , and C is in μ F.

Note: Normally installed values result in t = 620msec.

CURRENT/VOLTAGE REGULATOR STAGE

Selection of Current or Voltage regulation is made with PP1. If PP1-7 is closed, PP1-8 is open, and a 0/1Vdc voltage feedback signal is applied to J3-1 then the

board will operate as a voltage regulator. If PP1-7 is open, PP1-8 is closed, and a current feedback signal is applied to J2 then the board will operate as a current regulator. This section will assume that we are in current regulation mode. The operate is not effected by the source of the feedback signal.

The current feedback signal is connected to the inverting input of OP Amp U1-1, where it is compared to the threshold established by the attenuated current command signal established by the external command signal, the SPAN potentiometer (R2) and the BIAS potentiometer (R1). The amplified error between the current feedback and the bias level is formed by U1-1. The resulting error voltage is buffered by U3-14 and then attenuated by R14 and the SCR firing board input shunt resistor to form a 0.0 to 6.0Vdc Gate Delay Command Output voltage.

The response time to step changes in the Current Command input can be modified by changing C4. The gain of the current regulator can be affected by changing RN3 while the bandwidth can be adjusted with C5.

ELECTRICAL SPECIFICATION

The electrical specifications of the CTRCT-2 Current Trip/Regulator with CT Feedback Board are summarized in the table below. Part numbers refer to E371 Revision C.

Characteristic	Performance Requirement	Supporting Information
1) CT Feedback	1.0Aac maximum.	
2) Current Command Signal	0.0Vdc to 5.0Vdc control signal. Load resistance is 9.99k .	Option: A Shunt resistance (R11) across signal input can be selected for milliamp control signal.
3) Current feedback level	1.0Vdc at full load current.	Determined by CT ratio, circuit configuration, and R5 value.
4) Ambient Temperature	0°C to 70°C	
5) Status Drivers	I _{max} = 500mA P _{total} = 1.0W	Per transistor ⁴ Total package

CIRCUIT BOARD INTERCONNECTION DIAGRAMS

The following connection diagrams are included to provide an overview of the interconnections required between the CTRCT-2 Regulator Board and the Enerpro Firing Board (FCRO4100 or FCOG6100). Please contact Enerpro if there are any questions regarding the installation of these boards in your specific application.

⁴ The CTRCT-2 board can provide 100mA of current for remote status drivers. Higher current requirements will necessitate a remote power source.

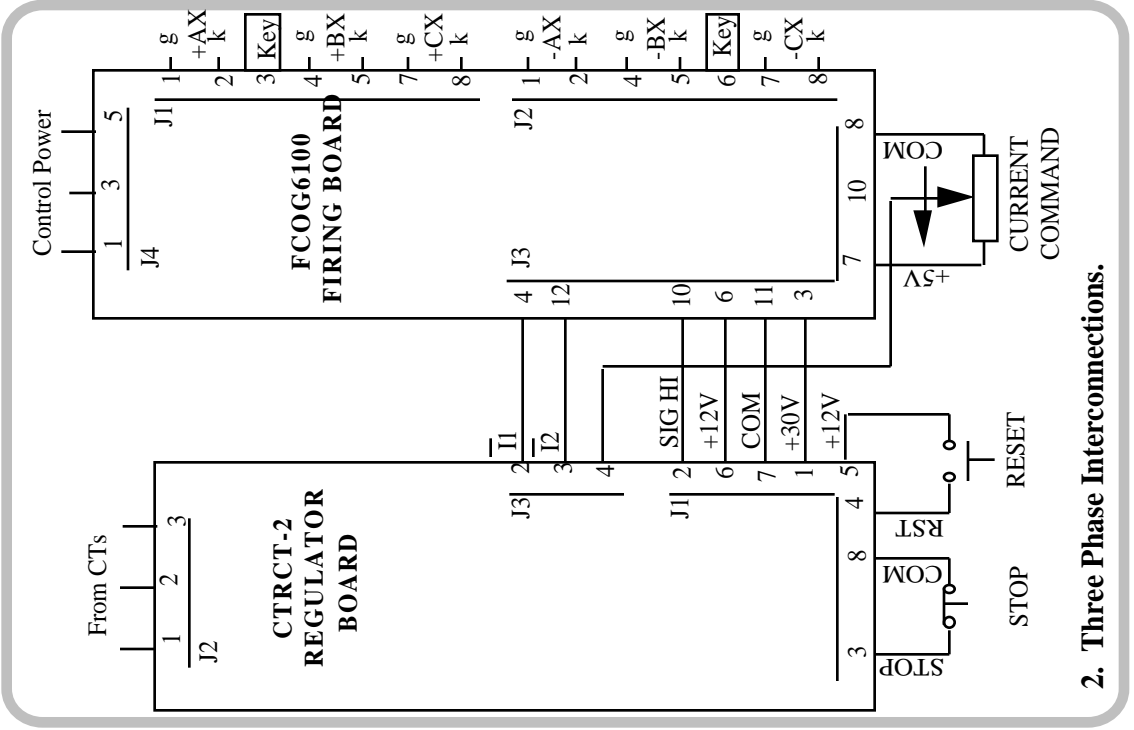
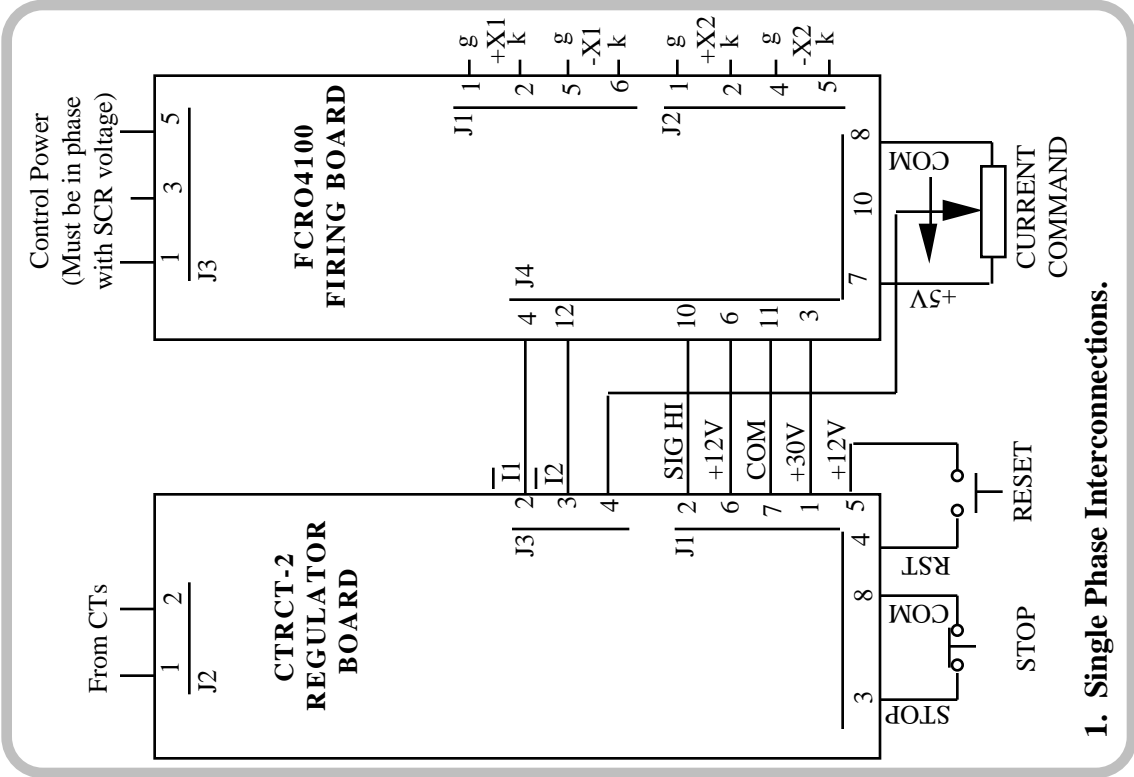

TROUBLESHOOTING GUIDE

The following table provides a list of possible fault conditions and the most likely courses of action required to obtain proper operation. The symptoms described will generally only occur upon initial installation and are provided to assist you during this crucial stage.

Symptom	Possible Cause	Corrective Action
No Power On indication	<ul style="list-style-type: none"> • No control power applied • Improper interconnection between circuit boards 	<ul style="list-style-type: none"> • Apply power • Verify +30V and COM connections
Unit comes on full upon start-up	<ul style="list-style-type: none"> • No feedback signal 	<ul style="list-style-type: none"> • Verify current transformer feedback or voltage feedback is connected • Verify that R5 has been installed
Unit will not provide minimum output	<ul style="list-style-type: none"> • BIAS potentiometer adjusted incorrectly 	<ul style="list-style-type: none"> • Adjust the BIAS potentiometer to obtain desired minimum output
Unit will not reach full output	<ul style="list-style-type: none"> • Feedback level too high • SPAN potentiometer adjusted incorrectly • Current Command level too low 	<ul style="list-style-type: none"> • Verify that R5 is selected to provide 1.0Vdc feedback • Adjust SPAN potentiometer toward 100% • Ensure voltage at TP9 reaches 2.5Vdc
Unit will not Start	<ul style="list-style-type: none"> • No COM connection to the STOP command 	<ul style="list-style-type: none"> • Connect COM to STOP command (J1-3)
Unit automatically resets	<ul style="list-style-type: none"> • Automatic Reset is selected • +12V is applied to the RESET connection 	<ul style="list-style-type: none"> • Remove CR9 • Disconnect +12Vdc from the RESET connection (J1-4)