

Fuse/Var CAPACITOR FUSES

Technical Data 38-852 Selection Guide



ABB Type	Voltage Rating (kV)	Rated Current (Amperes)	Interrupting Capability		Discharge Capability (Kilojoules)	Type (Combination) (Current Limiting) (Expulsion)	Application (Indoor) (Outdoor)	See Page Number
			Iind (kA)	Icap (kA)				
CLN	600 Volt	25A - 225A	200 kA	N/A	25K	Current Limiting	Indoor	3
	1.2 kV	25A - 175A	115 kA	1.25 kA	50K	Current Limiting	Indoor	
CLC	1.8 kV	25A - 175A	40 kA	1.25 kA	80K	Current Limiting	Indoor	5
	2.5 kV	25A - 75A	35 kA	1.25 kA	80K	Current Limiting	Indoor	
	3.0 kV	25A - 130A	35 kA	1.25 kA	100K	Current Limiting	Indoor	
	4.3/2.5 kV	25A - 75A	60 kA	1.25 kA	80K	Current Limiting	Indoor	
CIL	5.5 kV	15A - 65A	40 kA	2.9 kA	77K	Combination	Indoor	9
	8.3 kV	8A - 40A	60 kA	2.9 kA	75K	Combination	Indoor	
	15.5	6A - 25A	90 kA	800 Amps	88K	Combination	Indoor	
CXP	9.7 kV	6A - 100A	10 kA	1.9 kA	30K	Expulsion	Outdoor	13
	16.6 kV	6A - 50A	5 kA	2.1 kA	30K	Expulsion	Outdoor	
	26.2 kV	6A - 50A	2.5 KA	.8 kA	30K	Expulsion	Outdoor	
COL	2.8 kV	25A - 80A	40 kA	2.9 kA	85K	Combination	Outdoor	7
	5.5 kV	15A - 65A	40 kA	2.9 kA	77K	Combination	Outdoor	
	8.3 kV	8A - 40A	60 kA	2.9 kA	75K	Combination	Outdoor	
	15.5 kV	6A - 25A	90 kA	2.3 kA	88K	Combination	Outdoor	
	23.0 kV	6A - 15A	60 kA	800 Amps	50K	Combination	Outdoor	
CLXP	2.5 kV	15A - 33A	0	> 1.4 kA	No Limit	Combination	Outdoor	11
	5.0 kV	8A - 33A	0	> 1.4 kA	No Limit	Combination	Outdoor	
	8.0 kV	6A - 33A	0	> 1.4 kA	No Limit	Combination	Outdoor	
	10.0 kV	15A - 33A	0	> 1.4 kA	No Limit	Combination	Outdoor	
	15.0 kV	10A - 33A	0	> 1.4 kA	No Limit	Combination	Outdoor	
	20.0 kV	8A - 33A	0	> 1.4 kA	No Limit	Combination	Outdoor	
	25.0 kV	8A - 33A	0	> 1.4 kA	No Limit	Combination	Outdoor	

USEFUL CAPACITOR FORMULAE

NOMENCLATURE : "C" = Capacitance (microfarads)
 "V" = Voltage
 "A" = Current
 "K" = 1000

A. Capacitors connected in parallel :

$$C_{\text{total}} = C_1 + C_2 + C_3 + \dots$$

B. Capacitors connected in series :

1) For two (2) units

$$C_{\text{total}} = \frac{C_1 \times C_2}{C_1 + C_2}$$

2) For more than two (2) units

$$C_{\text{total}} = \frac{1}{\frac{1}{C_1} + \frac{1}{C_2} + \frac{1}{C_3} + \dots}$$

C. Reactance - X_c (Capacitive)

$$1) X_c = \frac{10^6}{(2\pi f)C} \quad 2) X_c = \frac{KV^2 \times 10^3}{KVAR}$$

$$3) X_c = \frac{2653}{C} \text{ @ 60 HZ (1 } \mu\text{F} = 2653 \text{)}$$

D. Capacitance - C

$$1) C = \frac{10^6}{(2\pi f)X_c} \quad 2) C = \frac{KVAR \times 10^3}{(2\pi f)(KV)^2}$$

E. Capacitive Kilovars

$$1) KVAR = \frac{(2\pi f)C \times (KV)^2}{10^3} \quad 2) KVAR = \frac{10^3 \times (KV)^2}{X_c}$$

F. Miscellaneous

1) Power Factor = $\cos \phi = KW/KVA$

	SINGLE PHASE	THREE PHASE
2) KW =	$\frac{V \times A \times PF}{10^3}$	$\frac{\sqrt{3} \times V \times A \times PF}{10^3}$
3) KVA =	$\frac{V \times A}{10^3}$	$\frac{\sqrt{3} \times V \times A}{10^3}$
4) Line Current =	$\frac{KVA \times 10^3}{V}$	$\frac{KVA \times 10^3}{\sqrt{3} V}$

5) Capacitor current = $(2\pi f)CV \times 10^{-6}$

$$\text{also : } \frac{KVAR \times 10^3}{V} \quad \frac{KVAR \times 10^3}{\sqrt{3} V}$$

6) KVA = KW/PF : (KW Motor Input)

$$7) KW \text{ (Motor Input)} = \frac{hp \times 0.746}{\text{efficiency}}$$

8) Approximate Motor KVA = Motor HP (at full load)

G. Additional

1) Improved voltage @ transformer due to capacitor addition

$$\% V. R. = \frac{KVAR \text{ (cap.)} \times \% \text{ Transformer Reactance}}{KVA \text{ (transformer)}}$$

2) Losses Reduction

$$\% L. R. = 100 - 100 \left(\frac{\text{Original PF}}{\text{Improved PF}} \right)^2$$

3) Operation at other than rated voltage and frequency

a) Reduced Voltage :

$$\text{Actual KVAR (output)} = \text{Rated KVAR} \left(\frac{\text{Actual Voltage}}{\text{Rated Voltage}} \right)^2$$

b) Reduced Frequency :

$$\text{Actual KVAR (output)} = \text{Rated KVAR} \frac{\text{Actual Frequency}}{\text{Rated Frequency}}$$

H. Back - to - Back Switching

$$I_r = 1.333 \sqrt{KVAR_{\text{eff}}/L}$$

I_r - peak inrush current in Kilo Amps

L - 10 μ H (assumed)

$$KVAR_{\text{eff}} = \frac{KVAR_1 \times KVAR_2}{KVAR_1 + KVAR_2}$$

CAPACITOR FUSE TERMINOLOGY

Amp-Squared seconds (I-Squared t)

An ideal fuse could be defined as a lossless smart switch that can thermally carry infinite continuous current, detect a pre-set change in the continuous current, and open automatically (instantly) to interrupt infinite fault currents at infinite voltages without generating transients. Unfortunately such a device with real world materials does not exist. Over the years a set of terms has been developed to apply capacitor fuses. The concept of applying fuses should be a simple engineering task. However fuse operation is a non-linear function. The resistance of fuse elements change nonlinearly as they melt and clear. This means that fuse development requires many laboratory experiments to empirically derive and plot the relationships. Below is a brief list and definition of the key terms used in the development and application of capacitor fuses.

APPLICATION RATINGS

Maximum Continuous Current Rating

The maximum current that the fuse can carry continuously without deterioration (including harmonics). This rating is determined by temperature rise tests and is valid for some maximum ambient temperature.

Maximum Rated Voltage

The maximum power system voltage that the fuse can clear against. For high voltage capacitor fuses this generally is defined as 8.3, 15.5, or 23 kV, the distribution system maximum voltages. Other voltage ratings may be available for special applications.

Maximum Parallel Energy

When a capacitor fails, the energy stored in its series group of capacitors is available to dump into the combination of the failed capacitor and fuse. The failed capacitor and fuse must be able to absorb or hold off this energy with a low probability of case rupture of the capacitor unit. The available energy is calculated by assuming that the parallel capacitance is charged to 1.1 times the crest of the ac rated voltage ($j=C/2xV^2$). For shunt capacitor applications the energy is equal to 3.19 joules per kvar. The available energy is then compared to the rating of the fuse and capacitor unit. This is one criteria for selecting either expulsion or current limiting fuses for a given application. If the parallel energy is above 20kJ or 6000 kvar we apply current limiting fuses. If the parallel energy is less than 20kJ and the available fault current is within the rating of our expulsion fuse, we will apply our CXP expulsion fuse.

Maximum Interrupting Current

Most capacitor fuses have a maximum power frequency fault current that they can interrupt. These currents may be different for inductive and capacitively limited faults. For ungrounded or multi-series group banks the faults are capacitive limited. Typically the available fault current for these banks is very low (less than 2 or 3 times the actual capacitor bank load current). Typically we will provide CXP expulsion fuses, if the parallel energy available is less than 20 kJ. For cases where the energy exceeds 20kJ we would apply CLXP current limiting fuses.

On single series group grounded wye or delta banks the faults are inductively limited. The fault current is limited only by the available system fault current. If the available energy is less than 20 kJ and the available fault current is low we would apply CXP expulsion fuses. If the fault current is higher we would apply COL current limiting fuses.

Fuse operation is caused by raising the temperature of the fuse element above its melting point. Fuse melting is an energy function. The heat generated by passing the fault current and the current from the parallel charged capacitors must melt the fuse element. The term "energy" is not generally used because it is very difficult to calculate. The resistance of the fuse element when the fuse is cool or operating at rated current is typically 10 to 50 milliohms. During a fuse operation the element temperature increases and causes the element resistance to increase. When the element melts and vaporizes the resistance increases at a more rapid rate, until the fuse clears and the resistance becomes infinite. To calculate the energy in the fuse, we would have to dynamically calculate the resistance of the fuse and integrate the square of the current times its dynamic resistance over the time period of the fuse operation. The term "I-squared t" or "Amp-Squared Seconds" was devised to avoid this calculation problem. I-squared t is proportional to energy ($J=I\text{-Squared} \times P$). The proportionality constant is the resistance of the element ($R=J/(I\text{-squared} \ t)$). The argument is as follows: If we pass a certain current through a fuse element, it will take a certain amount of time for the fuse to melt. If we test many different elements at many different currents, we can determine the I-squared t for the elements. For fast rates of energy input into the fuse the I-squared t to melt is very consistent. For long low current exposures, the fuse element will tend to transfer a portion of the heat to the fuse housing and the I-squared t to melt will therefore be much higher. For this reason, the term is used only for fuse operations that occur faster than about 0.1 or 0.01 seconds.

I-Squared t Withstand

Each time the temperature of a fuse element is raised near its melting point, the fuse deteriorates slightly. A curve can be plotted that shows the expected number of operations a fuse can survive for a given percent of its one shot I squared t to melt. This information is valuable, if the fuse is to be exposed to many switching operations or discharges. For applications with many such exposures we tend to supply fuse elements with a higher I-squared t to melt capability (Larger diameter element).

I-Squared t Let Through

The I-squared t required for the fuse to clear is always greater than the I-squared t to melt. Some additional time is always required for the fuse element to change its impedance from a finite number (resistance of the element at the time of melting) to an infinite value (the fuse element has opened and interrupted). The total I-squared t to clear is also the I-squared t let through. This is the I-squared t that the failed capacitor sees as the fuse is operating. The capacitor must be able to absorb this energy with a low probability of case rupture.

Fusing factor

Fuses are usually applied with some continuous current margin. The margin is typically in the range of 1.3 to 1.65 per unit. This margin is called the fusing factor. On a typical power system, the fuses may be exposed to higher steady state currents in the following ways: (1) The rated kvar of a capacitor unit for shunt applications is a minimum (kVar tolerance = 0/+15%), (2) if harmonics are available on the system, the capacitors will provide a low impedance path and more current will flow through the fuse, and (3) Capacitor units by standards must be able to operate at 1.1 times rated voltage or 1.35 times rated kVar continuously. The fusing factor allows for these conditions. If the application is known to have a large harmonic content, the increase in current should be included in the fuse selection process.

CAPACITOR FUSE APPLICATIONS

EXPULSION VS. CURRENT LIMITING FUSES

Fuse Operation

Fuses in general operate by melting a fusible element or link. As the element melts an arc is developed. Three things must be present to extinguish the arc: (1) Pressure, (2) Cooling, and (3) Stretching.

Expulsion Fuses

The CXP expulsion fuse provides a means of disconnecting a failed capacitor from the circuit by melting a tin-lead low current link. The shorted capacitor unit causes a large increase in the current through the fuse. The current is limited only by the power system reactance and the other capacitor units in series with the failed capacitor unit. The pressure is generated by the hot arc making contact with the fiber lining of the fuse tube. The link is cooled and stretched as it is forced out the tube. The fuse continues to conduct until a natural current zero occurs. The current zero is caused by the power system fault current crossing zero. If other capacitors are connected in parallel with the failed unit, all the stored energy in these capacitors will be absorbed in either the fuse operation of the failed capacitor unit. Most of the energy is absorbed in the failed capacitor.

Current Limiting Fuses

Capacitor current limiting fuses can be designed to operate in two different ways.

The COL fuse uses ribbons with a non-uniform cross section. This configuration allows the fuse to be used to interrupt inductively limited faults. The pressure is generated by the arc contained in the sealed housing. The cooling is provided by the sand around the fuse element. The element melts at each non-uniformity and develops a low back voltage. The back voltage limits the peak current by inserting what appears to be a higher impedance in the fuse path. The element path provides the stretching. The COL will not force the current to a zero value. The arc will wait for the first natural current zero and extinguish the arc at that time. The low current element will then drop out to provide an air gap for dielectric isolation. Since this fuse conducts to a natural zero and is developing a back voltage, a large portion of the energy is absorbed in the fuse. The energy is shared between the fuse and the failed capacitor unit.

The CLXP fuse uses a long uniform cross section element. This configuration makes the fuse a current chopping fuse. The fuse develops a back voltage per inch of element across the entire length of the element. When this voltage exceeds the available voltage across the fuse, the fuse forces the arc to extinguish. The cooling and pressure are provided in the same manner as on the COL fuse. The result is that a trapped voltage may and probably will remain on the other capacitors in the series group. The fuse by its design avoids absorbing all of the available energy on the series group. This fuse is used for capacitor banks with a large number of parallel capacitors. It can be used on applications with essentially infinite parallel stored energy, as long as sufficient back voltage can be developed to force the current to extinguish. This is the fuse we apply to series, large shunt, and DC banks. Because of the high back voltage that is developed, this fuse must be used with several capacitors in parallel to limit the voltage build up or a flashover may occur elsewhere in the capacitor rack. The design also can not be used in inductive limited fault applications.

AVAILABLE FAULT CURRENT

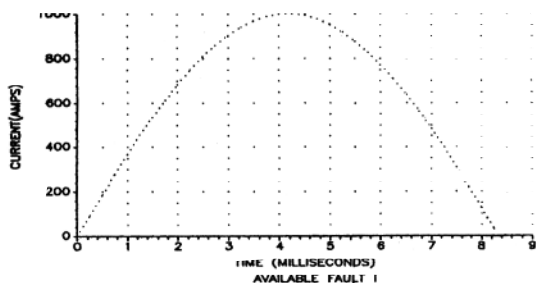

CXP FUSE CLEARING

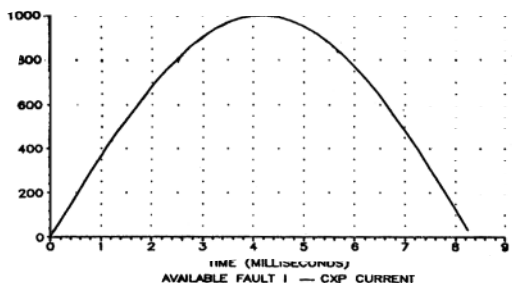

OIL & COL FUSE CLEARING

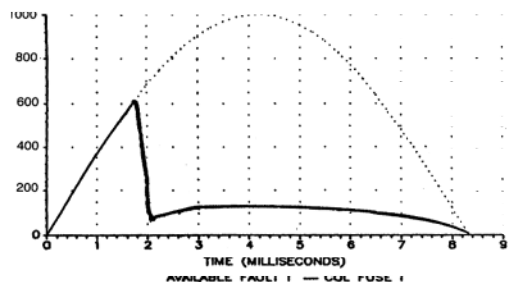

CLXP FUSE CLEARING

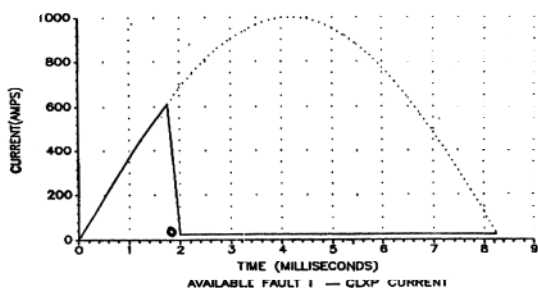

Type CLN - 600 Volt, Current Limiting, Non-Indicating, Indoor (Enclosed)

GENERAL DESCRIPTION

The Type CLN Fuse is a 600 volt full range current limiting capacitor fuse. It is designed for indoor use or in an enclosure, protected from outdoor weather conditions. The primary application of these fuses is individual unit fusing of low voltage single and three phase capacitors in metal enclosed equipments. These fuses are current limiting, non-indicating and non-disconnecting.

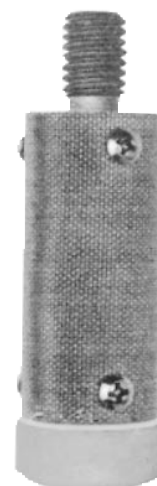

Low Voltage Fuse Application Data

Low voltage fuses are selected by taking the following steps:

1. Voltage:

The voltage of the capacitor being protected should be less than or equal to the voltage of the fuse selected. The nearest available fuse should be used to assure that the voltage developed by the fuse during interruption does not damage the system. On three phase capacitors, the fuse should have a rating equal to or exceeding the line to line voltage.

2. Interrupting capacity:

The interrupting capacities on the CLN fuse is more than adequate to protect low voltage capacitor applications.

Available Fault Current:

Rated KVA source XFMR/Impedance (source)

Divide by the voltage to obtain available fault current

EXAMPLE: 50 KVA/10% = 500,000 VA

for 480 V, I = 1042 amperes

All CLN Fuses are Rated 600 Volt

3. The continuous current rating of the fuse should be 1.65 times the current flowing in each phase to protect against harmonics at 600 volts and switching currents. (Also, capacitor tolerances are -0 +15%; and 480V is the nominal rating of that system, not the maximum.) To calculate the fuse rating (I_F), use the following formulas:

3-phase:
 $kVAR = kV \times I_C \times \sqrt{3}$

1-phase:
 $kVAR = kV \times I_C$

$$I_C = \frac{kVAR}{kV\sqrt{3}}$$

$$I_C = \frac{kVAR}{kV}$$

Fuse Current Rating

$$I_F = I_C \times 1.65$$

Ampere Rating	Interrupting Capacity Amperes	Style Number
25	200,000	4991C27A01
50	200,000	4991C27A02
75	200,000	4991C27A03
100	200,000	4991C27A04
125	200,000	4991C27A05
150	200,000	4991C27A06
175	200,000	4991C27A07
200	200,000	4991C27A08
225	200,000	4991C27A09

Type CLN Fuse Current Ratings Normal Applications

Single Phase Units

Three Phase Units

Single Phase Units			Three Phase Units					
1 Phase kVAC	240V	480V	600V	3 Phase kVAC	240V	480V	600V	
2.5	25A			2.5	25A			
5.0	50	25A		5.0	25	25A		
7.5	50	25	25A	7.5	50	25	25A	
10	75	50	50	10	50	50	25	
15	125	50	50	15	75	50	25	
20	150	75	75	20	100	50	50	
25	175	100	75	25	100	50	50	
30		100	100	30		75	50	
35		125	100	35		75	75	
40		150	125	40		100	75	
45		175	125	45		100	75	
50		175	150	50		100	100	
60		200	175	60		125	100	

Type CLN - 600 volt, Current Limiting, Non-Indicating, Indoor (Enclosed)

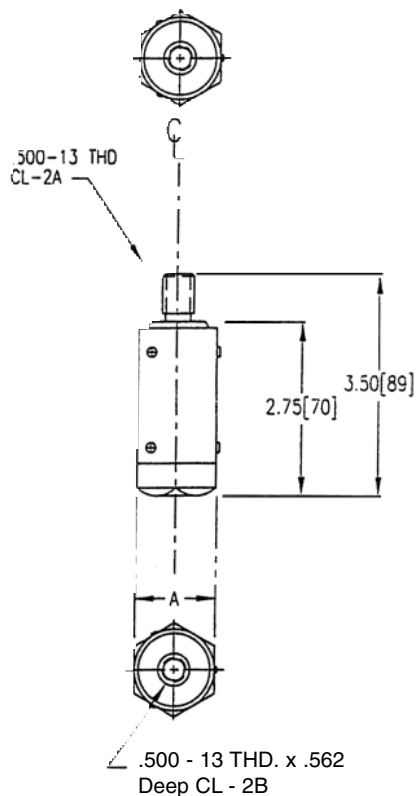

DIMENSION	VOLTS	CONT. AMPS	STYLE NO.
A			
1.000	600	25	4991C27 A01
		50	A02
		75	A03
		100	A04
		125	A05
		150	A06
1.250		175	A07
		200	A08
		225	A09

OEM Designs:

For special mounting dimensions to fit low voltage "original equipment" specifications, please see your ABB representative.

ADDITIONAL INFORMATION:

- Price List: PL 38-850
- Instruction: IL 38-851-1
- Melting Curves: 5111969
- Clearing Curve: 5111970
- Let-Thru Curve: 5111971

Type CLC - Indoor, Current Limiting Capacitor Fuse 1.2 - 3.0 kV

GENERAL DESCRIPTION

The Type CLC Fuse is a full range (partial range for 4.3/2.5kV ratings) current limiting capacitor fuse. It is designed for indoor use or in an enclosure, protected from outdoor weather conditions. The CLC fuses exist in 1200, 1800, 2500, 3000 volt and 4.3/2.5kV ratings. The primary application of these fuses is individual unit fusing of low voltage single and three phase capacitors in metal enclosed equipments. The 1200, 1800 and 3000 volt ratings are current limiting, indicating and non-disconnecting. The 2500 volt and 4.3/2.5kV ratings are current limiting, non-indicating and non-disconnecting.

APPLICATION:

CLC fuses are selected by taking the following steps:

- Voltage:**
The voltage of the capacitor being protected should be less than or equal to the voltage of the fuse selected. The nearest available fuse should be used to assure that the voltage developed by the fuse during interruption does not damage the system. The 4.3/2.5kV fuse is a special rating for 2500V single-phase applications or 4300V 3-phase applications. To protect a 4800V single-phase capacitor, use two 4.3/2.5kV fuses in series.
- Interrupting capacity:**
The interrupting capacity on CLC fuses is more than adequate to protect most applications.

Available Fault Current:

Rated KVA source XFMR/Impedance (source)

Divide by the voltage to obtain available fault current

EXAMPLE: 50 KVA/10% = 500,000 VA

for 480 V, I = 1042 amperes

- Continuous current:**
The continuous current rating of the fuse should be 1.65 times the current flowing in each phase to protect against harmonics and switching currents.

Selecting Type CLC Fuses

Single-Phase:

$$\text{Ampere rating } 1.65 \times \frac{\text{kVAR}}{\text{kV}}$$

Three-Phase Units:

$$\text{Ampere rating } 1.65 \times \frac{\text{kVAR}}{\sqrt{3} \text{ kV}}$$

Type CLC Fuse Ratings
Normal Applications On Typical 2400
And 4160 Volt Capacitor

Three Phase Units

3 Phase kVAC	2400V	4160V
25	25A, 2.5 kV	25A, 4.3/2.5 kV
50	25A, 2.5 kV	25A, 4.3/2.5 kV
75	5CA, 2.5 kV	25A, 4.3/2.5 kV
100	50A, 2.5 kV	25A, 4.3/2.5 kV
125	50A, 2.5 kV	50A, 4.3/2.5 kV
150	75A, 2.5 kV	50A, 4.3/2.5 kV
175	75A, 2.5 kV	50A, 4.3/2.5 kV
200	75A, 2.5 kV	50A, 4.3/2.5 kV

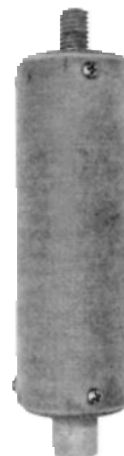

Ampere Rating	Interrupting Capacity Amperes	Style Number
1200-Volt Type CLC Current Limiting, Indicating, Indoor (Enclosed)		
25	115,000	4989C12A21
50	115,000	4989C12A22
75	115,000	4989C12A23
100	115,000	4989C12A24
120	115,000	4989C12A25
135	115,000	4989C12A26
150	115,000	4989C12A27
165	115,000	4989C12A28
175	115,000	4989C12A29
1800-Volt Type CLC Current Limiting, Indicating, Indoor (Enclosed)		
25	40,000	4989C12A41
50	40,000	4989C12A42
75	40,000	4989C12A43
100	40,000	4989C12A44
120	40,000	4989C12A45
135	40,000	4989C12A46
150	40,000	4989C12A47
165	40,000	4989C12A48
175	40,000	4989C12A49
2500-Volt Type CLC Current Limiting, non-Indicating, Indoor (Enclosed)		
25	35,000	4989C13A01
50	35,000	4989C13A02
75	35,000	4989C13A03
3000-Volt Type CLC Current Limiting, Indicating, Indoor (Enclosed)		
25	35,000	4989C12A61
50	35,000	4989C12A62
75	35,000	4989C12A63
100	35,000	4989C12A64
115	35,000	4989C12A65
130	35,000	4989C12A66
4.3/2.5kV Type CLC Current Limiting, non-Indicating, Indoor (Enclosed)		
25	60,000	4989C13A06
50	60,000	4989C13A07
75	60,000	4989C13A08

Note: Rated maximum voltage is 110% of nominal.
Ref: IEEE C37.40

Blown Fuse Indicator

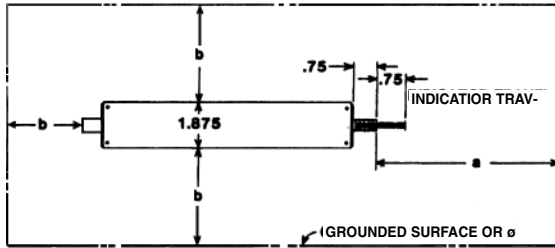

Outline

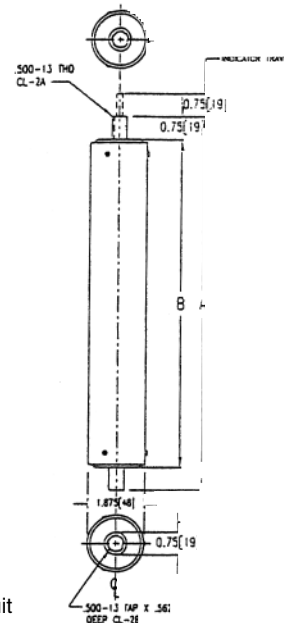

DIMENSIONS		
A	B	Volts
7.125	5.625	1200
9.125	7.625	1800
9.125	7.625	2500
12.375	10.875	3000
9.125	7.625	4.3/2.5 kV

CLC Fuse Voltage	Indicating?	a*	b**
1200	Yes	4.00	2.50
1800	Yes	5.00	2.50
2500	No	2.50	2.50
3000	Yes	6.00	2.50
4.3/2.5kV	No	2.50	2.50

*These dimensions are the recommended clearances for 60kV BIL equipment. Increase these dimensions if higher BIL is required.

**These dimensions are the minimum recommended clearances as determined by various 60 Hz. tests. These dimensions should be increased if feasible due to possible circuit variations and voltage transients.

Typical CLC Fuse Mounting Arrangements Are Shown Below:

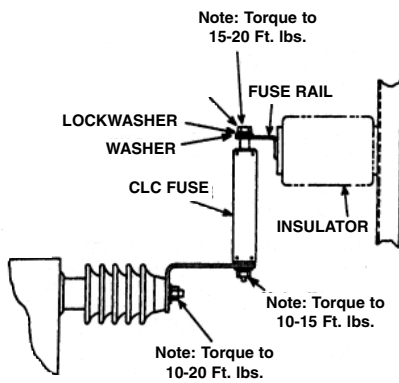

Type CLC Fuse/Capacitor
Edgemount Single Phase Capacitor

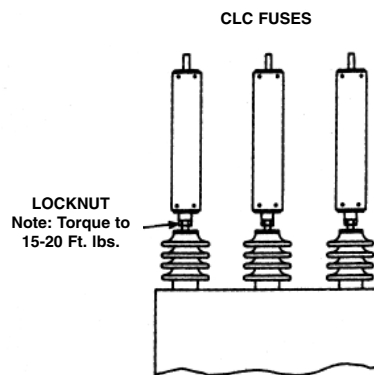

Type CLC Fuse/3-4.3/2.5 kV
Fuses Mounted on 3 Phase Capacitor

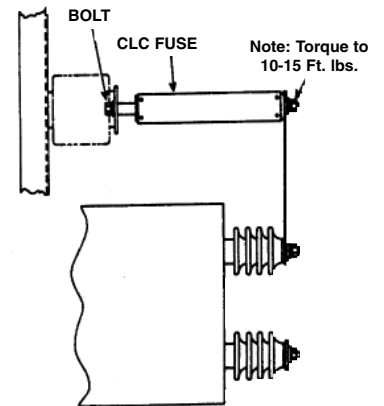

Type CLC Fuse/Capacitor
Edgemount on Single Phase Capacitor

ADDITIONAL INFORMATION:

- Price List PL 38-850
- Instruction Book IB 38-851-2
- Melting Curve 511936
- Total Clearing Curve 511937
- Maximum Let Thru 511938
- Design Test Report

General Description

The Type COL Fuse is a full range current limiting capacitor fuse. *It is designed for outdoor use only.* COL fuses exist in voltage classes of 2.8 kV, 5.5 kV, 8.3 kV, 15.5 kV and 23 kV, and are applied to individual capacitor units in outdoor stacking equipment. The COL fuse is current limiting, indicating and disconnecting.

The Type COL current limiting capacitor fuse is a two part design:

The high current section interrupts high 60 Hz fault currents and/or high frequency discharge current from parallel capacitors.

The low voltage section consists of a standard NEMA type K fuse link mounted in a fiber tube. The low current section interrupts fault current associated with progressive failure of the capacitor units is dielectric, or 60Hz fault current limited by the circuit impedance to low values.

This type of design reduces fuse replacement cost to the price of a NEMA type K fuse link when low current interruption occurs.

The COL capacitor fuse must be used with an ejector spring. (see page 8). This spring ejects the link's leader giving a position indication of a blown fuse.

Application

Voltage: The COL fuse is used only for fusing individual single phase capacitor cans. Therefore, the COL fuse voltage rating can be determined from the voltage rating of the capacitor unit - (see Table 1). Do not apply COL fuses above this rated voltage.

Energy: The COL fuse is generally used on those capacitor banks where parallel energy is more than 20 kilo-joules or 6000 kVAR. The COL fuse's maximum parallel capacitor discharge energy rating is shown in the **Technical Data** table.

COL fuses are to be applied ONLY where there are 2 or more capacitors in parallel per group and where low inductively limited faults can flow. See appendix.

Current

Table 1 lists the individual fusing recommendations for applying COL fuses in outdoor capacitor banks. The fusing tables are based on the following:

$$\text{Capacitor current} = \frac{\text{kVar unit}}{\text{kV unit}}$$

Minimum Fuse Current = Capacitor Current X 1.35 Protective Margin.

The protective margin accounts for normal overvoltages, harmonics, capacitor tolerances and a 25° C. ambient.

SELECT: Fuse Voltage and Current Rating
TABLE 1 (Fuse Current-Rating Based on Available Styles in Table 2)

Capacitor Voltage Rating	Fuse Voltage Rating (kV)	50 kVar	100 kVar	150 kVar	200 kVar	300 kVar	400 kVar
2400	2.8	35	65	92	-	-	-
2770	2.8	35	54	80	-	-	-
4160	5.5	21	34	49	65	-	-
4800	5.5	21	34	49	56	-	-
6640	8.3	11	21	33	47	-	-
7200	8.3	11	21	26	39	-	-
7620	8.3	11	21	33	39	-	-
7960	8.3	11	17	26	39	-	-
8320	8.3	11	17	26	33	-	-
9960	15.5	9	14	21	32	-	-
12470	15.5	9	12	21	26	-	-
13280	15.5	9	12	16	21	32	-
13800	15.5	9	12	16	21	32	-
14400	15.5	9	12	16	21	32	-
19920	23.0	-	8	11	14	21	-
21600	23.0	-	8	11	14	21	26
22800	23.0	-	8	11	14	21	26



Technical Data

	2.8	5.5	8.3	15.5	23.0
Maximum Design Voltage	2.8	5.5	8.3	15.5	23.0
Maximum Parallel Capacitor Discharge Energy Rating (Kilo-Joules)	85	77	75	88	50
Maximum 60 Hz Inductive Current Interrupting (kA RMS Sym.)	40	40	60	90	60
Maximum Peak Recovery Voltage (kV)	9	17	26	48	72

TABLE 2 (Select Fuse Style Number)
STYLE NUMBER INCLUDES FUSE LINK

Maximum Fuse Design Voltage (kV)	**Rated Maximum Voltage	Continuous Current Rating (Amps) (40°C) (55°C)	NEMA Type K Fuse Link Hardware	Type CIL With Mounting
2.8	3.08	35	25	279C410A01
2.8	3.08	42	30	279C410A02
2.8	3.08	54	40	279C410A03
2.8	3.08	65	50	279C410A04
2.8	3.08	80	65	279C410A05
2.8	3.08	92	80	279C410A06
5.5	6.05	21	15	279C410A08
5.5	6.05	27	20	279C410A09
5.5	6.05	34	25	279C410A10
5.5	6.05	40	30	279C410A11
5.5	6.05	49	40	279C410A12
5.5	6.05	56	50	279C410A13
5.5	6.05	65	65	279C410A14
8.3	9.13	11	8	279C410A16
8.3	9.13	14	10	279C410A17
8.3	9.13	17	12	279C410A18
8.3	9.13	21	15	279C410A19
8.3	9.13	26	20	279C410A20
8.3	9.13	33	25	279C410A21
8.3	9.13	39	30	279C410A22
8.3	9.13	47	40	279C410A23
8.3	9.13	50	50	279C410A24
8.3	9.13	65	65	279C410A25
15.5	17.05	9	6	279C410A26
15.5	17.05	12	8	279C410A27
15.5	17.05	14	10	279C410A28
15.5	17.05	16	12	279C410A29
15.5	17.05	21	15	279C410A30
15.5	17.05	26	20	279C410A31
15.5	17.05	32	25	279C410A32
23.0	25.3	8	6	279C410A36
23.0	25.3	11	8	279C410A37
23.0	25.3	14	10	279C410A38
23.0	25.3	16	12	279C410A39
23.0	25.3	21	15	279C410A40
23.0	25.3	25	20	279C410A41

* Based on 35° Ambient. Fuse links are rated based on their melting characteristics. They can carry approximately 150% of their rating continuously.

** Ref: IEEE C37.40

Type COL - (Outdoor) Current Limiting Capacitor Fuse

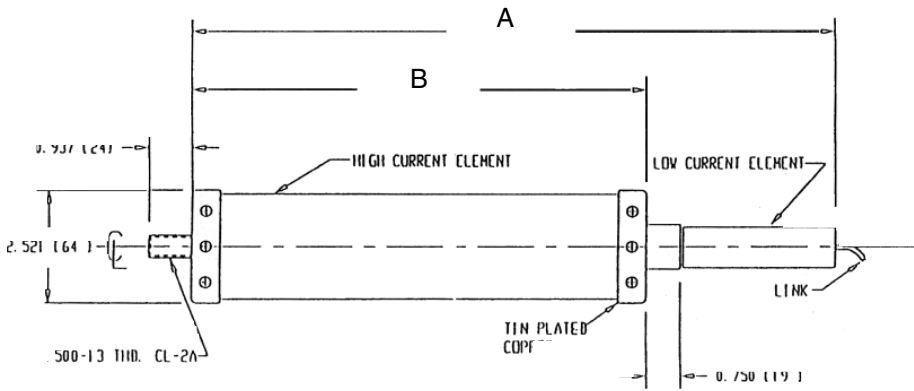

	A	B	Weight Lbs.
2.8kV	11.075	7.750	3.0
5.5kV	11.075	7.750	3.0
8.3kV	11.075	7.750	3.0
15.5kV	14.125	10.00	3.6
23.0kV	16.250	12.125	4.3

Mountings & Ejector Spring

The COL fuse must be used with ejector springs. The critical dimension is the distance from the capacitor bushing to the end of the fuse tube. Proper fit is important in order to avoid unnecessary adjacent capacitor fuse operations. Many styles are available of the torsion springs shown below. See your ABB representative for proper fit.

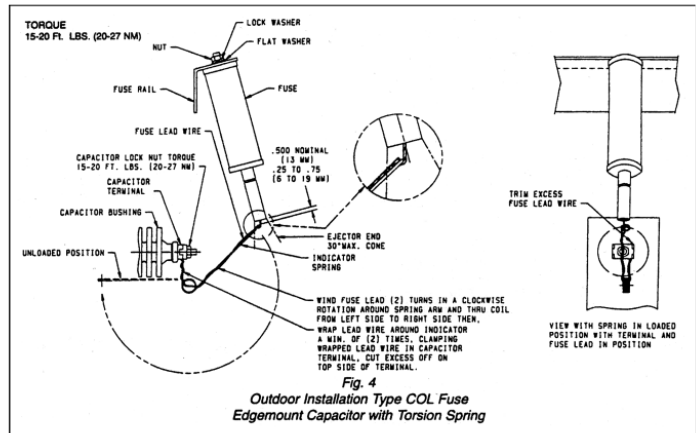
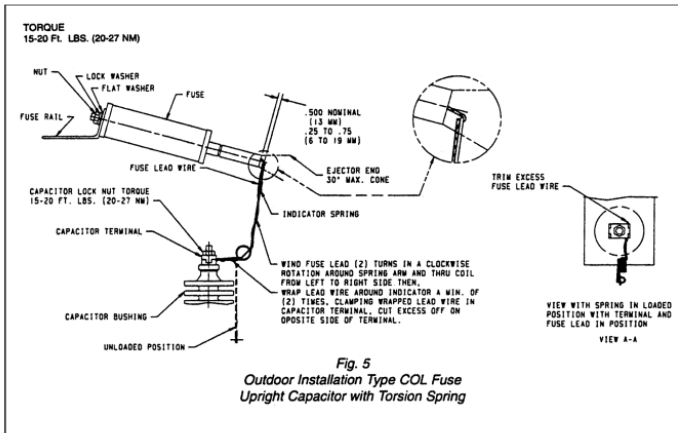

ADDITIONAL INFORMATION:

- Price List: PL 38-850
- Instruction: IL 38-851-1
- Melting Curves: 5111969
- Clearing Curve: 5111970
- Let-Thru Curve: 5111971

Type CIL Fuses - (Indoor) Current Limiting Capacitor Fuse For Use In Metal - Enclosed Equipment

General Description

The Type CIL Fuse is a full range current limiting capacitor fuse. It is designed for indoor use only. CIL fuses exist in voltage classes of 5.5 kV, 8.3 kV, 15.5 kV and 23kV. The primary application of these fuses is individual capacitor unit fusing for metal enclosed equipments. The CIL fuse is current limiting, indicating and disconnecting.

The Type CIL current limiting capacitor fuse is a two part design:

The high current section interrupts high 60 Hz fault currents and/or high frequency discharge current from parallel capacitors.

The low voltage section consists of a standard NEMA type K fuse link mounted in a fiber tube. The low current section interrupts fault current association with progressive failure of the capacitor unit DIELECTRIC, or 60Hz fault current limited by the circuit impedance to low values.

This type of design reduces fuse replacement cost to the price of a NEMA type K fuse link when low current interruption occurs.

The CIL capacitor fuse must be used with an ejector spring. (see page 10). This spring ejects the link's leader giving a position indication of a blown fuse.

Application

Voltage: The CIL fuse is used only for fusing individual single phase capacitor cans. Therefore, the CIL fuse voltage rating can be determined from the voltage rating of the capacitor unit - (see Table 1). Do not apply CIL fuses above their rated voltage.

Energy: The CIL fuse is generally used on those capacitor banks where parallel energy is more than 20 kilo-joules or 6000 kVAR. The CIL fuse's maximum parallel capacitor discharge energy rating is shown in the **Technical Data** table.

CIL fuses are to be applied ONLY where there are 2 or more capacitors in parallel per group and where low inductively limited faults can flow. See appendix.

Current

Table 1 lists the individual fusing recommendations for applying CIL fuses in indoor capacitor banks. The fusing tables are based on the following:

$$\text{Capacitor Current} = \frac{\text{kVar unit}}{\text{kV unit}}$$

$$\text{Minimum Fuse Current} = \text{Capacitor Current} \times 1.35 \text{ Protective Margin.}$$

The protective margin accounts for normal overvoltages, harmonics, capacitor tolerances and a 40° C. ambient.

Note: Table 1 current ratings are based on 40° C. ambient style numbers shown in Table 2. Derated current ratings for 55° C. ambient applications, are also shown in Table 2.

SELECT: Fuse Voltage Rating and Current Rating (40°C)
TABLE 1 (The Fuse Current Ratings Shown are Based on Available Fuse Styles Shown in Table 2)

Capacitor Voltage Rating	Fuse Voltage Rating(kV)	50 kVar	100 kVar	150 kVar	200 kVar	300 kVar
2400	5.5	34	56	-	-	-
2770	5.5	27	56	-	-	-
4160	5.5	21	34	49	65	-
4800	5.5	21	34	49	56	-
6640	8.3	11	21	33	47	-
7200	8.3	11	21	33	39	-
7620	8.3	11	21	33	39	-
7960	8.3	11	17	26	39	-
8320	15.5	9	16	26	32	-
9960	15.5	9	14	21	32	-
12470	15.5	9	12	16	26	32
13280	15.5	-	12	16	21	32
13800	15.5	-	12	16	21	32
14400	15.5	-	9	14	21	32
19920	23.0	-	-	-	21	21
21600	23.0	-	-	-	21	21

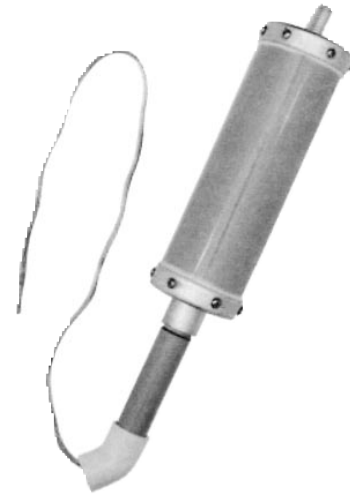

Technical Data

Maximum Design Voltage (kV)	2.8	5.5	8.3	15.5	23.0
Maximum Parallel Capacitor Discharge Energy Rating (Kilo-Joules) 5 kHz	85	77	75	88	50
Maximum 60 Hz Inductive Current Interrupting (kA RMS Sym.)	40	40	60	90	60
Maximum Peak Recovery Voltage (kV)	9	17	26	48	72

TABLE 2 (Select Fuse Style Number)
STYLE NUMBER INCLUDES FUSE LINK

Maximum Fuse Design Voltage (kV)	**Rated Maximum Voltage	Continuous Current Rating (Amps) (40° C)	Continuous Current Rating (Amps)* (55° C)	NEMA Type K Fuse Link Hardware	Type CIL With Mounting
5.5	6.05	21	18	15	279C420A08
5.5	6.05	27	23	20	279C420A09
5.5	6.05	34	29	25	279C420A10
5.5	6.05	40	34	30	279C420A11
5.5	6.05	49	42	40	279C420A12
5.5	6.05	56	48	50	279C420A13
5.5	6.05	65	55	65	279C420A14
8.3	9.13	11	9	8	279C420A16
8.3	9.13	14	12	10	279C420A17
8.3	9.13	17	14	12	279C420A18
8.3	9.13	21	18	15	279C420A19
8.3	9.13	26	22	20	279C420A20
8.3	9.13	33	28	25	279C420A21
8.3	9.13	39	33	30	279C420A22
8.3	9.13	47	40	40	279C420A23
15.5	17.05	9	8	6	279C420A26
15.5	17.05	12	10	8	279C420A27
15.5	17.05	14	12	10	279C420A28
15.5	17.05	16	14	12	279C420A29
15.5	17.05	21	18	15	279C420A30
15.5	17.05	26	22	20	279C420A31
15.5	17.05	32	27	25	279C420A32
23.0	25.3	21	18	15	279C420A40

*Fuse links are rated based on their melting characteristics. They can carry approximately 150% of their rating continuously.

** Ref: IEEE C37.40

Type CIL - (Indoor) Current Limiting Capacitor Fuses

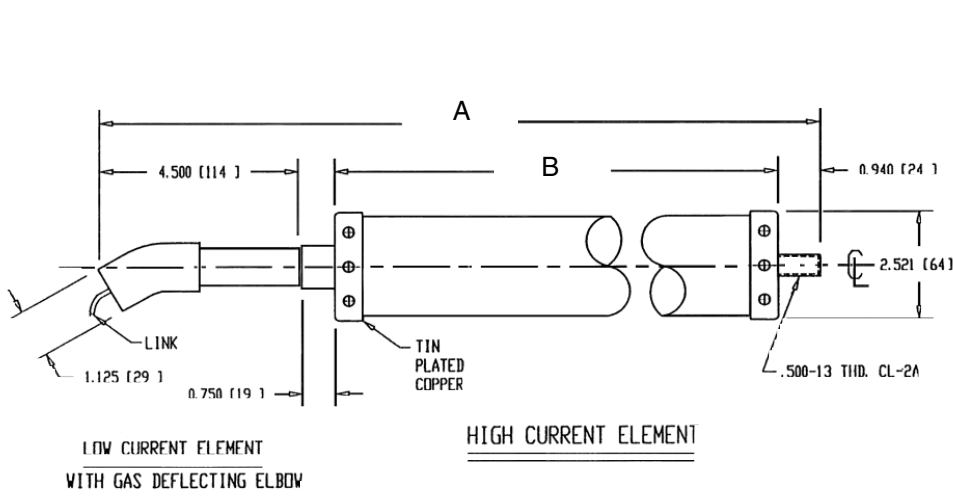

	(Lbs.)		
	A	B	Weight
5.5kV	14.00	7.75	3.5
8.3kV	14.00	7.75	3.5
15.5kV	16.25	10.00	4.2
23.0kV	18.375	12.125	4.5

Mounting & Ejector Spring

The CIL fuse must be used with style number 898A431H02 ejector spring (fuse indicator). The gas deflecting elbow must be positioned such that the opening points to the capacitor unit.

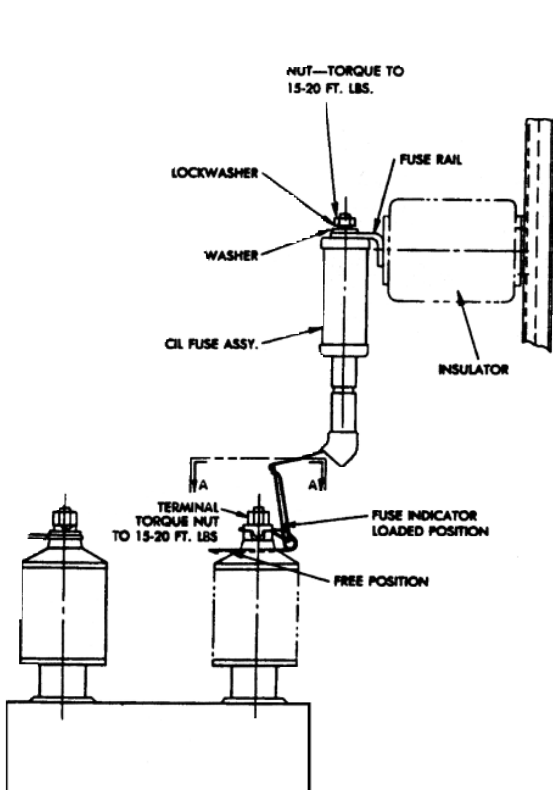

Indoor Installation
Type CIL Fuse /Capacitor Upright

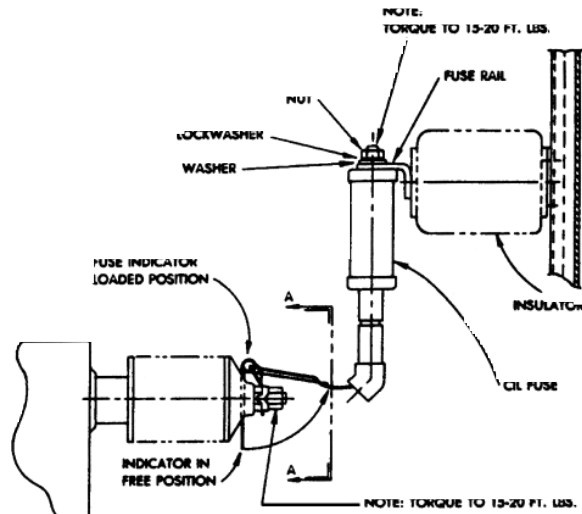

Indoor Installation
Type CIL Fuse /Capacitor Edgemount

ADDITIONAL INFORMATION:

- Price List: PL 38-850
- Instruction: IL 38-851-1
- Melting Curves: 5111969
- Clearing Curve: 5111970
- Let-Thru Curve: 5111971

Type CLXP - (Outdoor) "High Energy" Current Limiting Capacitor Fuse

Description

The Type CLXP Fuse is a very high energy capability individual capacitor fuse. It is for application in outdoor capacitor banks with many parallel capacitor units.

It contains a current limiting section of the "silversand" type of construction with an interrupting rating of 60,000 amperes asymmetrical and can successfully dissipate the stored energy discharge of any number of parallel connected capacitors.

In addition, it has a separate low current interrupting section similar to the Type CXP fuse. This section contains a standard fuse link.

Advantages of the CLXP fuse compared to earlier current limiting fuses are:

1. Improved interrupting characteristics.
2. Improved energy dissipating ability.
3. Less susceptible to unwanted fuse blowings.
4. Low current faults, may be inexpensively refused by simply replacing the fuse link in the low current section.

The CLXP capacitor fuse must be used with an ejector spring. (see page 12). This spring ejects the link's leader giving a position indication of a blown fuse.

Application

Voltage: The CLXP fuse is used only for fusing individual single phase capacitor cans. Therefore, the CLXP fuse voltage rating can be determined from the voltage rating of the capacitor unit. Do not apply CLXP fuses above their rated voltage.

Energy: The CLXP fuse is generally used on those capacitor banks where parallel energy is more than 20 kilo-joules or 6000 kVAR. The CLXP fuse's maximum parallel capacitor discharge energy rating is unlimited.

The Type CLXP fuse should not be used on single series group grounded wye or single series group delta connected capacitor banks.

The CLXP fuse is used on capacitor banks with large number of parallel capacitors. The CLXP can be used on applications with essentially infinite parallel stored energy, as long as sufficient back voltage can be developed to force the current to extinguish. The fuse is usually applied to series, large shunt, and DC capacitor banks. Because of the high back voltage that is developed, this fuse must be used with several capacitors in parallel to limit the voltage build up or a flashover may occur elsewhere in the capacitor bank. The CLXP cannot be used in inductively limited fault applications.

Current

CLXP fuse current rating is based on the following:

$$\text{Capacitor Current} = \frac{\text{kVar unit}}{\text{kV unit}}$$

Fuse Current Rating = Capacitor Current X 1.35 Protective Margin.

The protective margin accounts for normal overvoltages, harmonics, capacitor tolerances and a 25° C. ambient.



CLXP FUSE STYLES

Many styles of CLXP fuses are available. The design range from 7.3 kV to 33.6 kV max AC design voltage, to 50 amps high current elements and low current element tube capable of using up to 65k links.

STYLE NUMBERS INCLUDE THE FUSE LINK

Some typical styles are:

Style No.	kV	Rating **Rated Maximum Voltage	Max.	
			Amps	Link*
174C660A30	5.5	6.05	50	65K
174C660A31	6.5	7.15	46	40T
4995C51A04	8.3	9.13	41	40K
174C660A12	9.3	10.23	22	15T
174C660A10	9.3	10.23	34	25T
174C660A49	10.5	11.55	38	40K
4995C51A07	12.2	13.42	31	25T
174C660A32	13.2	14.52	33	30T
4995C51A14	14.9	16.39	15	10T
4995C51A26	14.9	16.39	30	30K
174C660A33	17.4	19.14	24	20T
4995C51A23	18.2	20.02	23	20K

*Fuse links are rated based on their melting characteristics. They can carry approximately 150% of their rating continuously.

** Ref: IEEE C37.40

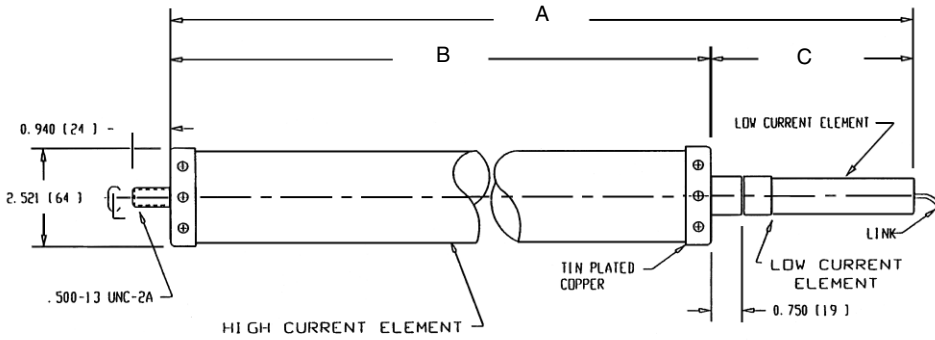

Voltage (kV)	A	B	C	LBS
2.5	12.625	7.625	5.0	3.0
5.0	12.625	7.625	5.0	3.0
8.0	12.625	7.625	5.0	3.0
10	12.625	7.625	5.0	3.0
15	17.125	12.125	5.0	4.3
20	17.125	12.125	5.0	4.3
25	17.125	12.125	5.0	4.3

The CLXP fuse must be used with ejector springs. The critical dimension is the distance from the capacitor bushing to the end of the fuse tube. Proper fit is important in order to avoid unnecessary adjacent capacitor fuse operations. Many styles are available of the torsion springs shown below. See your ABB representative for proper fit.

Mounting & Ejector Spring

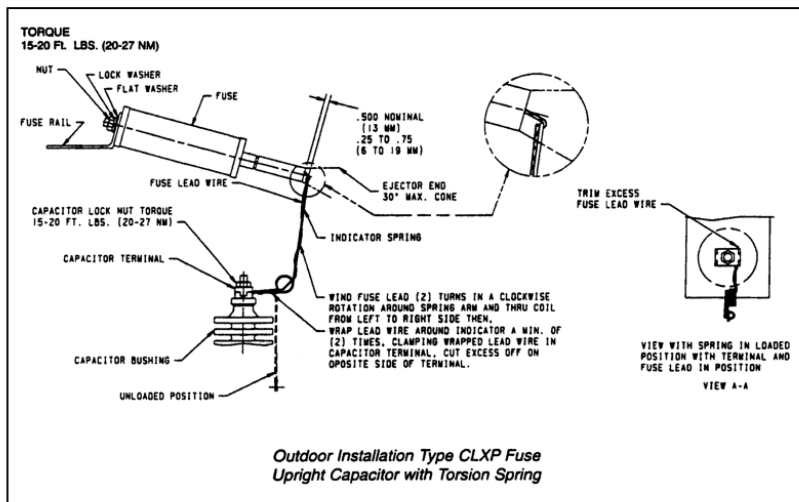
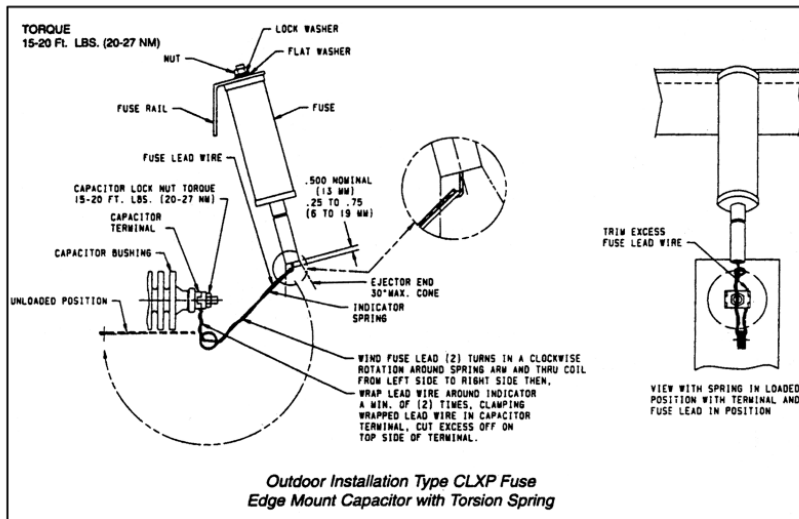

ADDITIONAL INFORMATION:

Price List: PL 38-850
 Instruction: IL 38-851-1
 Clearing Curve: 5111969
 Let-Thru Curve: 5111971

Type CXP - High-Voltage, Expulsion, Capacitor Fuse

DESCRIPTION/APPLICATION:

The Type CXP Fuse is an expulsion fuse. It is designed for outdoor use only. CXP fuses exist in voltage classes of 8 kV, 15/20 kV and 25 kV. The primary application of these fuses is individual capacitor unit fusing in outdoor standard equipments. These fuses have a parallel energy capability of 30,000 Joules. They are not normally applied with more than 20,000 Joules of parallel energy, equivalent to 6000 kVAR of capacitors because of the possibility of capacitor case rupture. Do not use Type CXP fuses if the available fault current exceeds levels indicated below:



Fuse Rating	*Rated Maximum Voltage	Fuse Applied At	Interrupting Rating (60 Hz, Amps RMS)	
			Sym.	Asym.
9.7 kV	10.67	8 kV	7,400	10,000
16.6 kV	18.26	15 kV	3,600	5,000
26.2 kV	28.82	20 kV	1,800	2,500
26.2 kV	28.82	25 kV	1,800	2,500

* Ref: IEEE C37.40

Fuse Rating (kV)	Capacitor Unit Voltage kV	For Aluminum or Copper Bus	
		Tin Plated Brass End Cap Style Number*	For Aluminum Bus Only (Aluminum End Cap) Style Number*
9.7	2.4 to 8.8	IC09100A02	IC09100A01
16.6	8.3 to 15.1	IC09100A04	IC09100A03
26.2	15.1 to 23.8	IC09100A06	IC09100A05

*Styles Do Not include fuse link.

The Type CXP Fuse is designed for outdoor use only and should be used only in the following cases:

1. In all ungrounded wye applications.
2. In all grounded wye applications when the capacitor units are connected in 2 or more series groups.
3. In a grounded wye applicaiton with 1 series group and the available fault current does not exceed the level indicated above.

Note: The CXP capacitor fuse must be used with an ejector spring (see page 14). This spring ejects the link's leader giving a positive indication of a blown fuse.

APPLICATION:

Interrupting and Energy Limits:

Available short circuit current must be measured at the capacitor unit location. Type CXP fuses applied on capacitor units in a single series group will see the full short circuit current of the system. Fuses applied on capacitor units in more than 1 series group a failed capacitor will see less than the system available short circuit - limited by the capacitor in other series groups.

In appling the CXP fuse, it is recommended that no more than 6000 KVAR (20,000 Joules) be applied in parallel in a series group to avoid possible capacitor case rupture.

Voltage:

The CXP voltage rating should be equal to or greater than the capacitor can voltage times 1.1.

LINK SELECTION:

Type CXP Expulsion fuses

Capacitor current $I_c = \text{kVAR unit} / \text{unit}$
 Select a link where link rating is equal to or greater than 0.9 of the I_c

Link rating $\geq 0.9 \times I_c$
 Link Rating to choose from. 8K, 10K, 12K, 15K, 20K, 25K, 30K, 40K, 50K

Rationalization:

Desired fusing factor is $I_c \times 1.35$ or greater
 Link ampacity is rating times 1.50
 $1.35 / 1.5 = 0.9$ therefore choosing a link at ≥ 0.9 of I_c will result of a minimum fusing factor of 1.35

Example: 200 kVAR, 9960 volt capacitor

$I_c = 200 / 9.96 = 20.08 \times 0.9 = 18.07$
 Next higher link rating = 20K
 Link ampacity is $20 \times 1.5 = 30$
 Fusing factor $30 / 20.08 = 1.49$

Capacitor Unit Voltage kV	Capacitor Unit kVAC					
	50	100	150	200	300	400
2.40	20K	40K	65K	N/A	N/A	N/A
4.16	12K	25K	40K	50K	N/A	N/A
4.80	10K	20K	30K	40K	65K	N/A
6.64	8K	15K	25K	30K	50K	65K
7.20	8K	15K	20K	25K	40K	50K
7.62	6K	12K	20K	25K	40K	50K
7.96	6K	12K	20K	25K	40K	50K
8.32	6K	12K	20K	25K	40K	50K
9.54	6K	10K	15K	20K	30K	40K
9.96	6K	8K	15K	20K	30K	40K
11.40	6K	8K	12K	20K	25K	40K
12.00	6K	8K	12K	15K	25K	30K
12.47	6K	8K	12K	15K	25K	30K
13.28	6K	8K	12K	15K	25K	30K
13.80	6K	8K	10K	15K	20K	30K
14.40	6K	8K	10K	15K	20K	25K
17.20	6K	6K	8K	12K	20K	25K
19.92	6K	6K	8K	10K	15K	20K
20.80	6K	6K	8K	10K	15K	20K
21.60	6K	6K	8K	10K	15K	20K
22.80	6K	6K	6K	8K	12K	20K
23.80	6K	6K	6K	8K	12K	20K
24.94	6K	6K	6K	8K	12K	15K

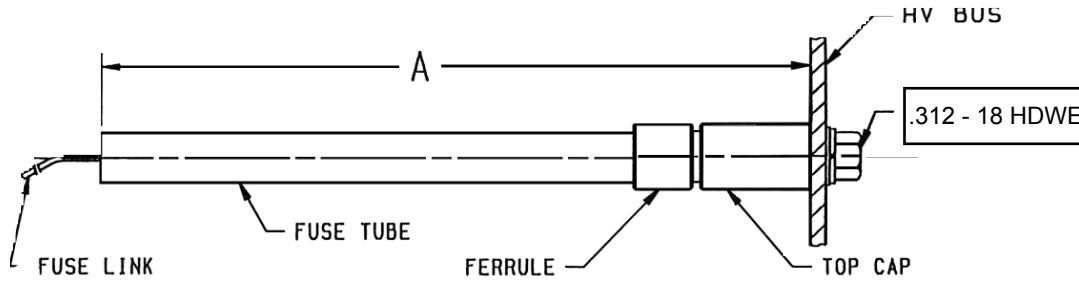

MAX. VOLTS	DIM. A (IN)	FUSE TUBE OD (IN.)	MAX. LINK SIZE	OZ.
9700V	8.250	.875	100 Amp.	6.5
16,600V	10.00	.75	50 Amp.*	6.0
26,200V	10.00	.75	50 Amp.*	6.0

Mountings & Ejector Springs

The CXP fuse must be used with ejector springs. The critical dimension is the distance from the capacitor bushing to the end of the fuse tube. Proper fit is important in order to avoid unnecessary adjacent capacitor fuse operations. Many styles are available of the torsion springs shown below. See your ABB representative for proper fit.

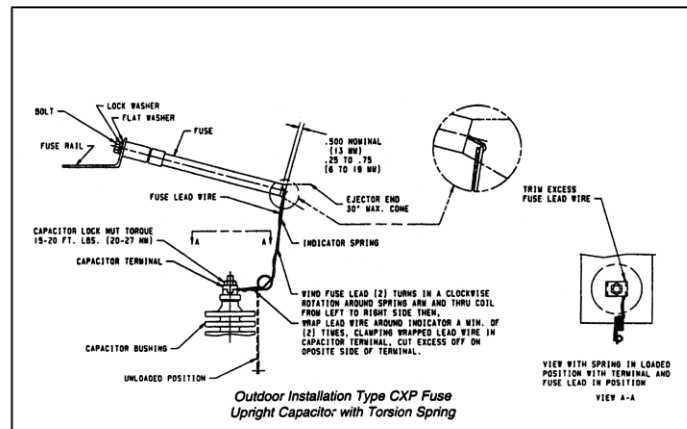
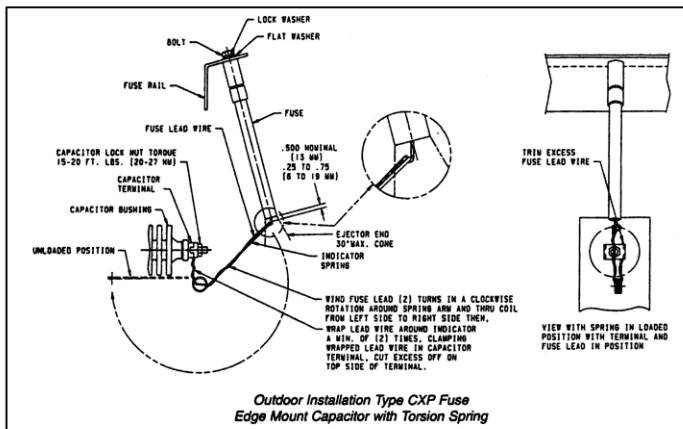

Other Information
Price list PL 38-850
Instruction: IL 38-851-5
Design Test Report

Example: Determine maximum parallel energy.

- E = 2.64 (1.10)² watt-seconds per kVAR
- E = 3.19 watt-seconds per kVAR for 10% overvoltage condition
- E = 3.80 watt-seconds per kVAR for 20% overvoltage condition

Example: 5 series groups, 10 ea. 200 KVAR, 13280 V capacitor units per series group

Rule: The size and number of capacitors connected in parallel in any one series group should not result in more than 20,000 watt-seconds being liberated into a faulted capacitor unit when using type CXP expulsion fuse.

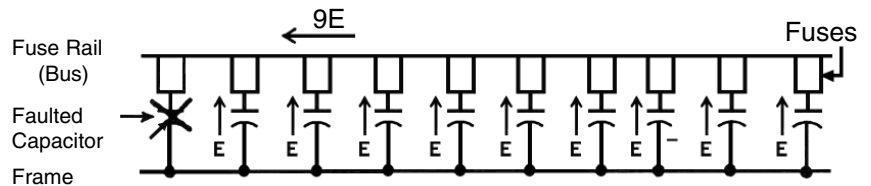

Energy through fuse ahead of faulted capacitor = $3.19 \frac{\text{watt-seconds}}{\text{kVAC}} \times 9 \text{ units} \times 200 \frac{\text{kVAR}}{\text{unit}} = 5742 \text{ watt-seconds}$

Select a 15 kV type CXP expulsion fuse

Rule: Current limiting type COL fuses should be used when the maximum parallel kVAR exceeds 6000 kVAR.

Single series group capacitor bank.

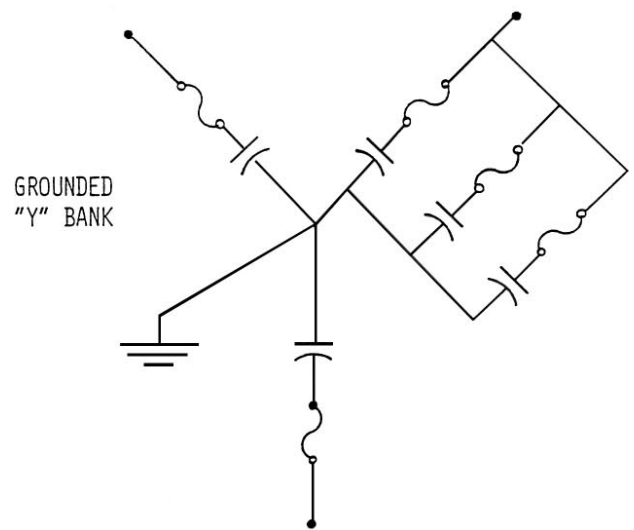
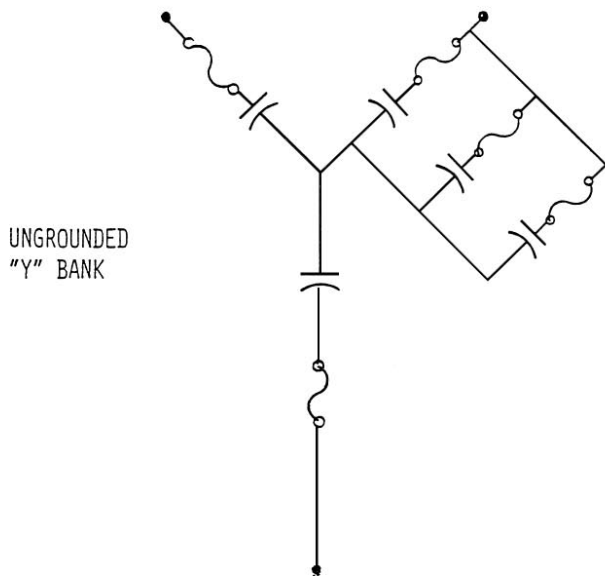

Safe fusing zone to avoid capacitor case rupture on high voltage units

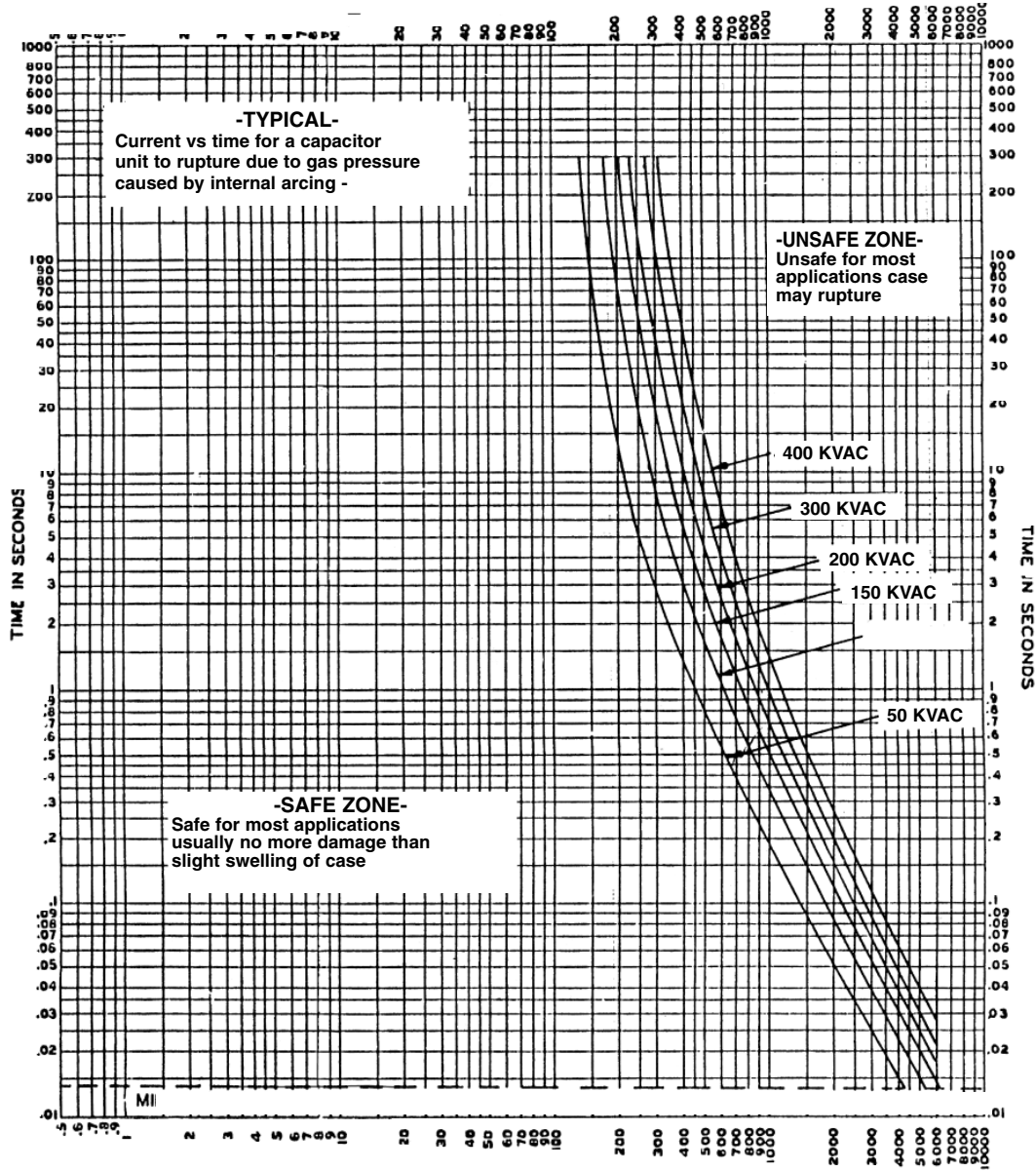

AVAILABLE SHORT CIRCUIT CURRENT RMS AMPERES

FOR TIMES SHORTER THAN ONE CYCLE, USE ASYMMETRICAL RMS AMPERES



ABB Power T&D Company Inc.

300 North Curry Pike, 47404
P.O. Box 341, 47402-0341
Bloomington, Indiana USA
Tel: 812-332-4421
Fax: 812-335-4274



CABLE JOINTS, CABLE TERMINATIONS, CABLE GLANDS, CABLE CLEATS
FEEDER PILLARS, FUSE LINKS, ARC FLASH, CABLE ROLLERS, CUT-OUTS

11KV 33KV CABLE JOINTS & CABLE TERMINATIONS
FURSE EARTHING
www.cablejoints.co.uk
Thorne and Derrick UK

Tel 0044 191 490 1547 Fax 0044 191 477 5371
Tel 0044 117 977 4647 Fax 0044 117 9775582

ISO 9000 Certified

TD 38-852-1/99