

Current Transducer LT 4000-S/SP24

$I_{PN} = 3300 \text{ A}$

For the electronic measurement of currents : DC, AC, pulsed..., with a galvanic isolation between the primary circuit (high power) and the secondary circuit (electronic circuit).

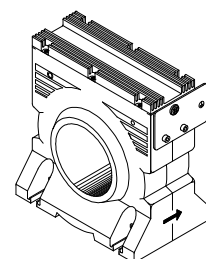

Electrical data

I_{PN}	Primary nominal r.m.s. current	3300	A			
I_p	Primary current, measuring range	0 .. ± 5000	A			
R_M	Measuring resistance	$R_{M \min}$	$R_{M \max}$			
		with $\pm 24 \text{ V}$	@ $\pm 3300 \text{ A}_{\max}$	0	17	Ω
			@ $\pm 5000 \text{ A}_{\max}$	0	6	Ω
I_{SN}	Secondary nominal r.m.s. current	660	mA			
K_N	Conversion ratio	1 : 5000				
V_C	Supply voltage ($\pm 5\%$)	± 24	V			
I_C	Current consumption	$35 + I_S$	mA			
V_d	R.m.s. voltage for AC isolation test, 50 Hz, 1 mn	6 ¹⁾	kV			
		1 ²⁾	kV			

Accuracy - Dynamic performance data

X_G	Overall accuracy @ $I_{PN}, T_A = 25^\circ\text{C}$	± 0.3	%	
e_L	Linearity error	< 0.1	%	
I_O	Offset current @ $I_p = 0, T_A = 25^\circ\text{C}$	Typ	Max	
			± 0.8	mA
I_{OT}	Thermal drift of I_O - $25^\circ\text{C} \dots +70^\circ\text{C}$	± 0.6	± 0.8	mA
t_r	Response time ³⁾ @ 90 % of I_{PN}	< 1	μs	
di/dt	di/dt accurately followed	> 50	A/ μs	
f	Frequency bandwidth (- 1 dB)	DC .. 100	kHz	

General data

T_A	Ambient operating temperature	- 25 .. + 70	$^\circ\text{C}$
T_S	Ambient storage temperature	- 40 .. + 85	$^\circ\text{C}$
R_S	Secondary coil resistance @ $T_A = 70^\circ\text{C}$	15	Ω
m	Mass	6.3	kg
	Standards	EN 50155 : 1995	

Notes : 1) Between primary and secondary + shield
 2) Between secondary and shield
 3) With a di/dt of 100 A/ μs .

Features

- Closed loop (compensated) current transducer using the Hall effect
- Insulated plastic case recognized according to UL 94-V0.

Special features

- $I_{PN} = 3300 \text{ A}$
- $I_p = 0 \dots \pm 5000 \text{ A}$
- Shield between primary and secondary
- Connection to secondary circuit on LEMO EGJ. 1B. 304. CYC.

Advantages

- Excellent accuracy
- Very good linearity
- Low temperature drift
- Optimized response time
- Wide frequency bandwidth
- No insertion losses
- High immunity to external interference
- Current overload capability.

Applications

- Single or three phases inverter
- Propulsion and braking chopper
- Propulsion converter
- Auxiliary converter
- Battery charger.

Application Domain

- Traction

Dimensions LT 4000-S/SP24 (in mm. 1mm = 0.0394 inch)

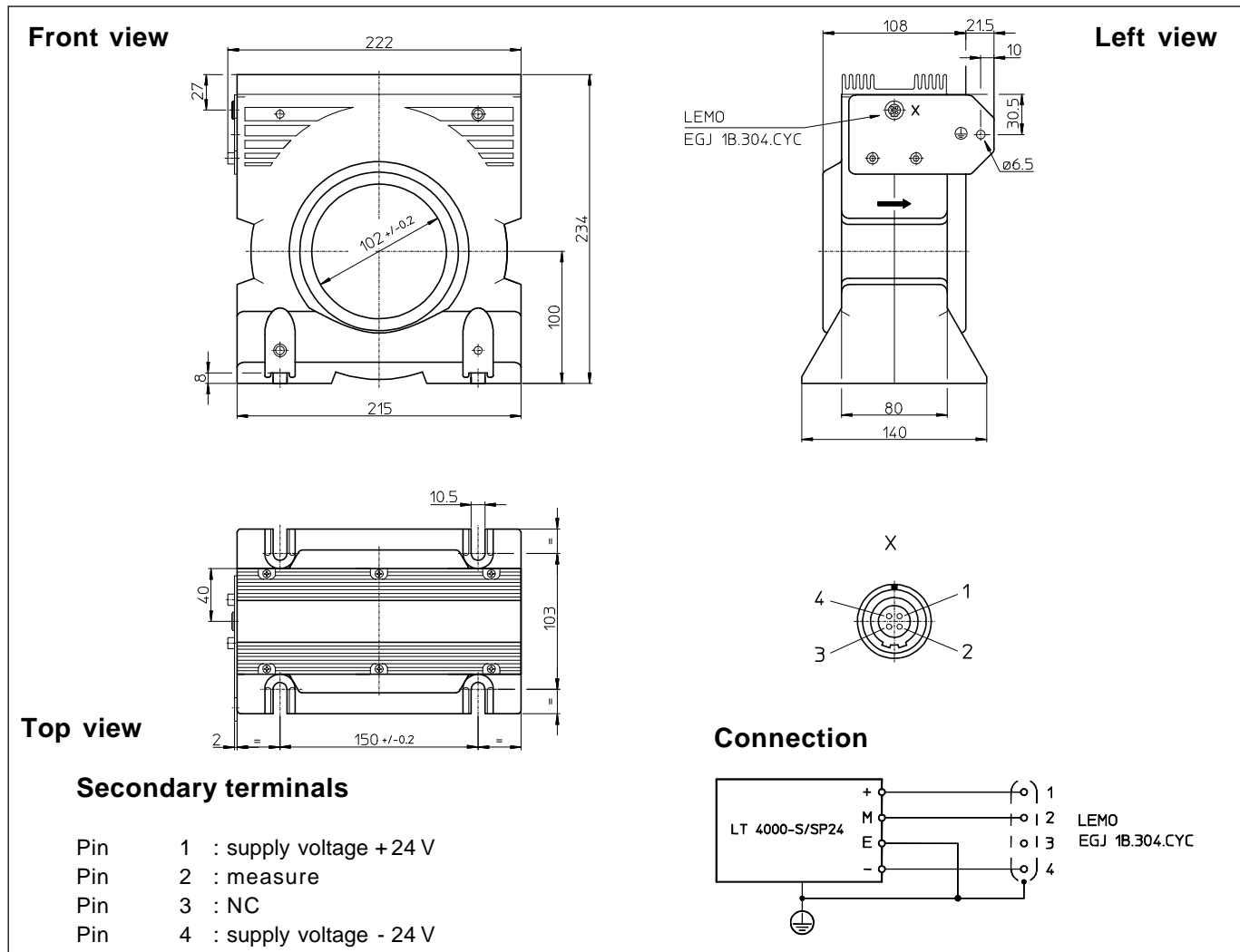

Mechanical characteristics

- General tolerance ± 1.0 mm
- Transducer fastening
 - 4 slots $\varnothing 10.5$ mm
 - 4 M10 steel screws
- Recommended fastening torque 11.5 Nm or 8.48Lb - Ft
- Primary through-hole $\varnothing 102$ mm
- Secondary connection LEMOEGJ.1B.304.CYC
- Earth connection hole $\varnothing 6.5$ mm

Remarks

- I_s is positive when I_p flows in the direction of the arrow.
- Temperature of the primary conductor should not exceed 100°C.
- Dynamic performances (di/dt and response time) are best with a single bar completely filling the primary hole.

Safety



This transducer must be used in electric/electronic equipment with respect to applicable standards and safety requirements in accordance with the following manufacturer's operating instructions.



Caution, risk of electrical shock

When operating the transducer, certain parts of the module can carry hazardous voltage (eg. primary busbar, power supply). Ignoring this warning can lead to injury and/or cause serious damage.

This transducer is a built-in device, whose conducting parts must be inaccessible after installation.

A protective housing or additional shield could be used.

Main supply must be able to be disconnected.