

Feature

- Designed for medium frequency welding equipment and optimized for high current rectifiers
- Proven high reliability in welding equipment with very Low on-state voltage and very low thermal resistance

V_{RRM}	200V
$I_{F(AVM)}$	7100A
V_{FO}	0.74V
r_F	0.026m Ω

SYMBOL	CHARACTERISTIC	TEST CONDITIONS	VALUE	UNIT
V_{RRM}	Repetitive peak reverse voltage	Half sine waveform, 50HZ $T_Q=10ms$	200	V
V_{RSM}	Maximum peak reverse voltage	Half sine waveform, $T_Q=10ms$	300	
I_{RRM}	Repetitive peak reverse current	$V_R=V_{RRM}$, $T_J=170^\circ C$	≤ 50	mA
$I_{F(AVM)}$	Max.average on-current	$T_C=85^\circ C$, Half sine pulse	7100	A
$I_{F(RMS)}$	Max.surge current integral	$T_C=85^\circ C$, Half sine pulse	11200	A
I_{FSM}	Max.peak non-repertitive surge current	$T_Q=8.3ms$, $V_R=0V$, Half sine pulse	55000	A
		$T_Q=10ms$, $V_R=0V$, Half sine pulse	60000	
$\int i^2 dt$	Max.surge current integral	$T_Q=8.3ms$, $V_R=0V$, Half sine pulse	15100	KA ² S
		$T_Q=10ms$, $V_R=0V$, Half sine pulse	15000	
V_F	Max.on-state voltage	$I_F=5000A$	≤ 1.05	V
V_{FO}	Max.Threshold voltage		0.74	V
r_F	Max.Slope resistance	$I_F=5-15KA$	0.026	m Ω
T_j	Operating junction temperature range	-40-170 $^\circ C$		
T_{stg}	Storage temperature range	-40-170 $^\circ C$		
$R_{th(j-h)}$	Thermal resistance junction to case	Anode side cooled	20	K/kw
		Cathode side cooled	20	
		Double side cooled	10	
$R_{th(c-h)}$	Thermal resistance case to heatsink	Anode side cooled	10	K/kw
		Cathode side cooled	5	
F_M	Max.on-state voltage		20	KN
W_t	Weight		0.14	kg
D_S	Surface creepage distance		4	mm
D_a	Air strike distance		4	mm
Outline				

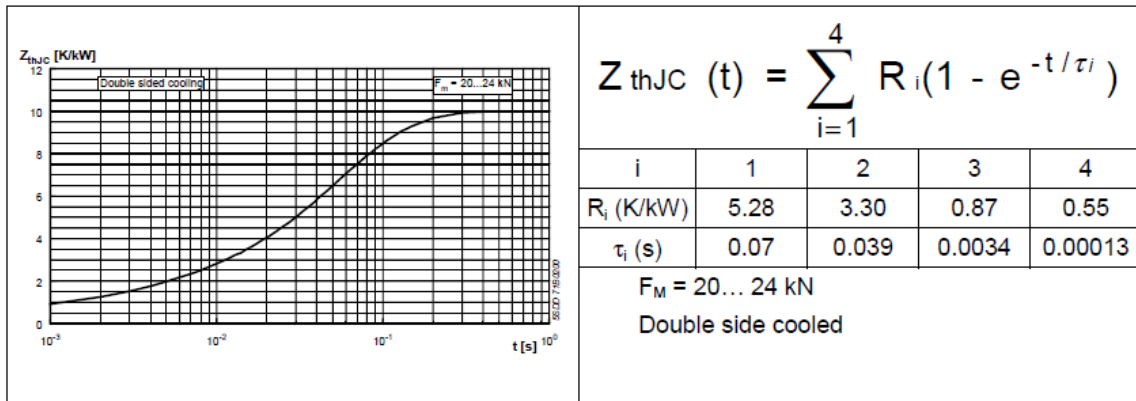

Fig. 2 Transient thermal impedance (junction-to-case) vs. time in analytical and graphical forms.

On-state characteristics

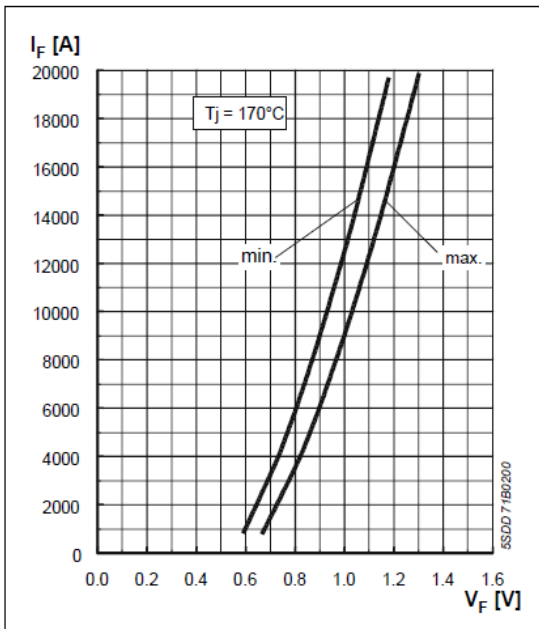

Fig. 3 Forward current vs. forward voltage (min. and max. values).

Surge current characteristics

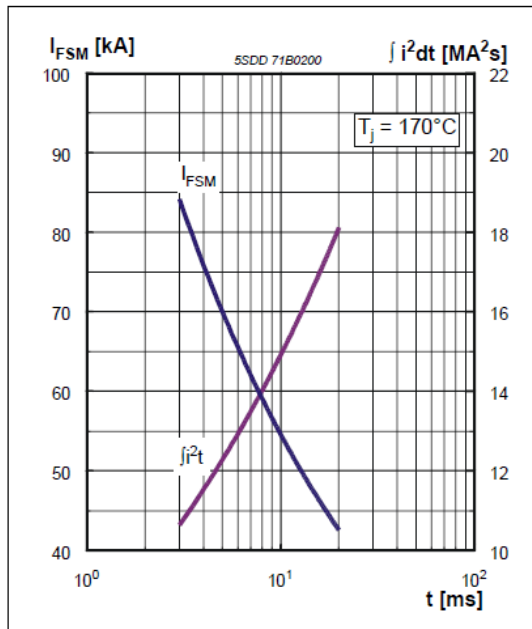

Fig. 4 Surge current and fusing integral vs. pulse width (max. values) for non-repetitive, half-sinusoidal surge current pulses.

Current load capability

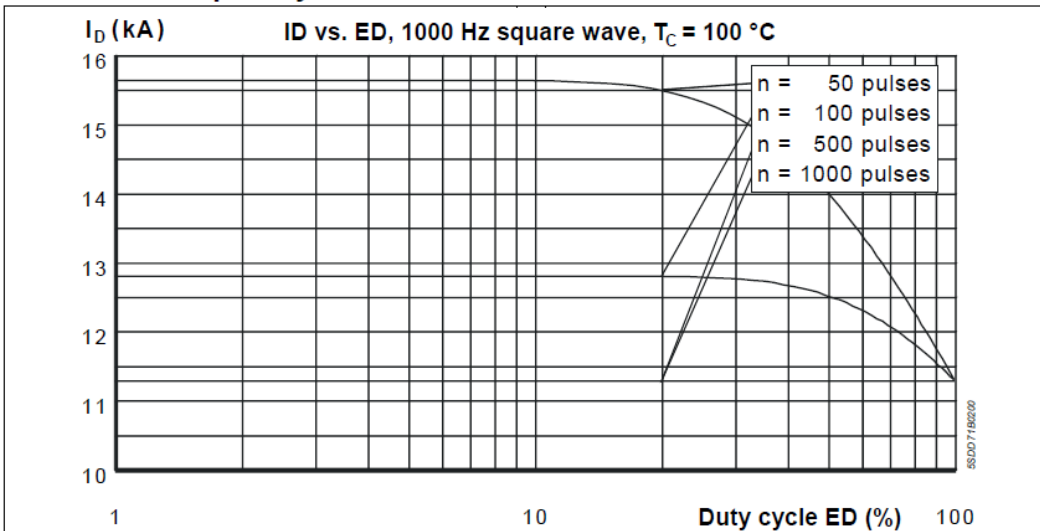

Fig. 5 DC-output current with single-phase centre tap

Current load capacity, cont.

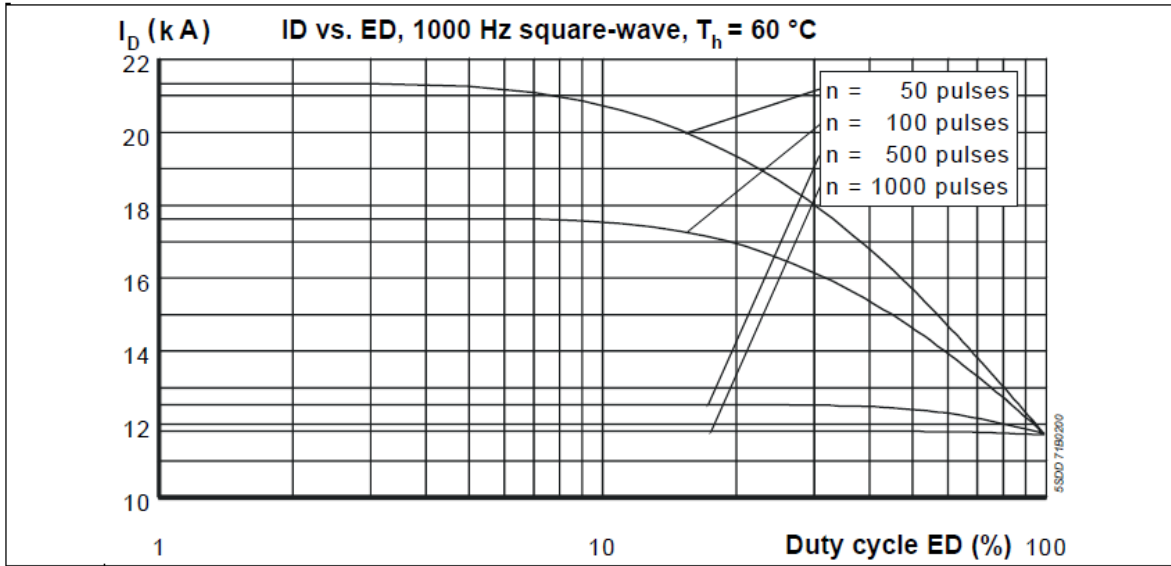

Fig. 6 DC-output current with single-phase centre tap

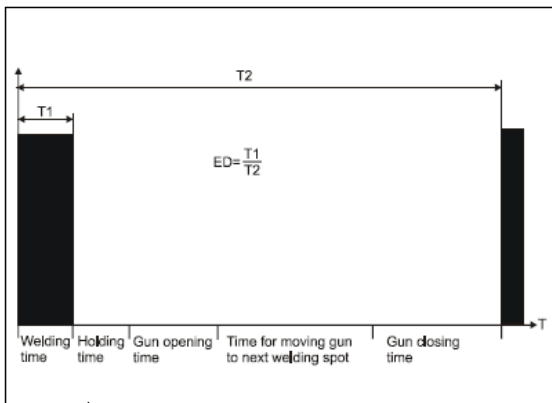

Fig. 7 Definition of ED for typical welding sequence

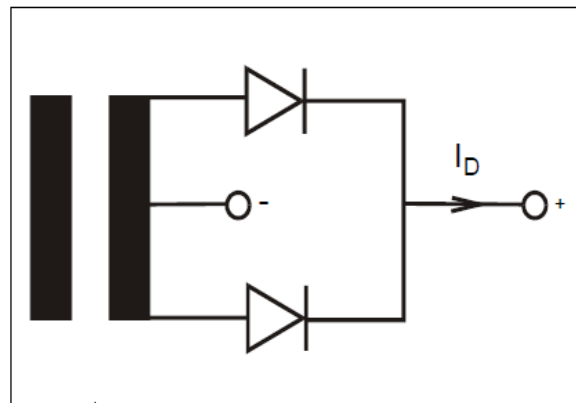

Fig. 8 Definition of ID for single-phase centre tap

