

Technical Requirements

1. The limit deviation of the unmarked dimension is in accordance with GB/T1804-F.
2. The injection molded parts should be free of burrs, bubbles, burnt spots, surface scratches, etc.
3. The flashing of pouring gate and overflow edge is less than 0.3 after trimming, and without damaging the body.
4. Unmarked excessive rounded corners is R0.3-R1.
5. Fit with the shape of the corresponding assembly joint surface less than 0.5 matching.
6. Each indentation of ejector pushing rod should be below the production surface less than 0.2.

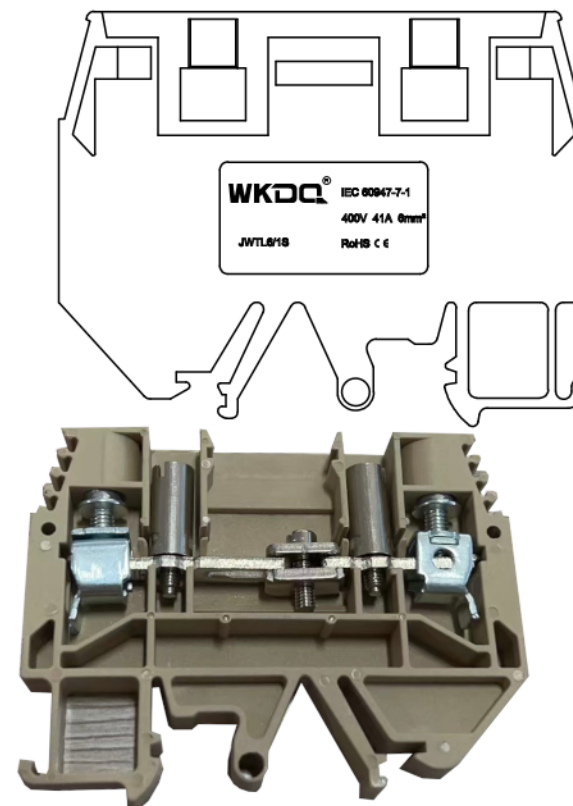
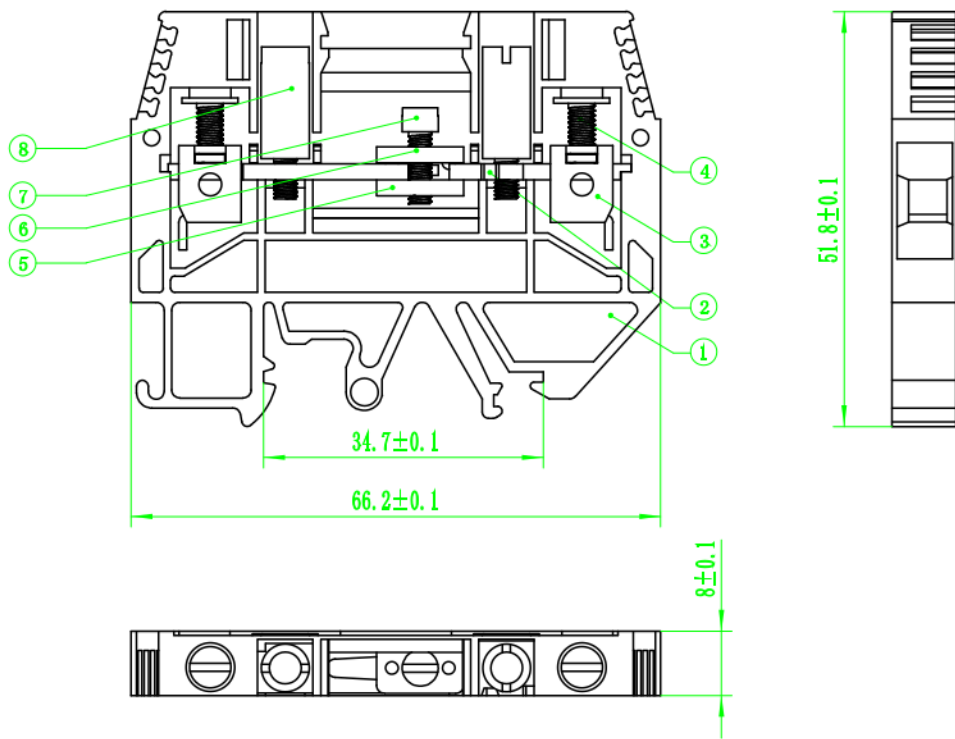

No	Name of parts	Quantity	Material	Surface Treatment
8	JWTL6/1S Brass tube	1	Brass	Nickel plating
7	JWTL6/1S M3X9	1	Q235	Zinc plating
6	JWTL6/1S Up sliding block	1	Brass	Nickel plating
5	JWTL6/1S Down Sliding block	1	Brass	Nickel plating
4	JWTL6/1S M3X8	2	Q235	Zinc plating
3	JWTL6/1S Clamping yoke	2	Steel	Nickel plating
2	JWTL6/1S Conductor	2	Brass	Nickel plating

1 JWTL6/1S Main body		1	PA66	Remark									
No	Name of parts	Part number	QTY	Material	Remark								
<table border="1"> <tr> <td>Design : Panhong</td> <td>Date: 21.06.11</td> </tr> <tr> <td>Proofread: Youbia</td> <td>Date: 21.06.14</td> </tr> <tr> <td>Review : Xianjun</td> <td>Date: 21.06.23</td> </tr> <tr> <td>Approval : Zhewei</td> <td>Date: 21.06.27</td> </tr> </table>		Design : Panhong	Date: 21.06.11	Proofread: Youbia	Date: 21.06.14	Review : Xianjun	Date: 21.06.23	Approval : Zhewei	Date: 21.06.27	Name: JWTL6/1S			
Design : Panhong	Date: 21.06.11												
Proofread: Youbia	Date: 21.06.14												
Review : Xianjun	Date: 21.06.23												
Approval : Zhewei	Date: 21.06.27												
<table border="1"> <tr> <td>Unmarked dimension tolerance (mm)</td> <td>± 0.15</td> </tr> <tr> <td></td> <td>.0 ± 0.1</td> </tr> <tr> <td></td> <td>.00 ± 0.05</td> </tr> </table>		Unmarked dimension tolerance (mm)	± 0.15		.0 ± 0.1		.00 ± 0.05	Figure no: JWTL6/1S					
Unmarked dimension tolerance (mm)	± 0.15												
	.0 ± 0.1												
	.00 ± 0.05												
<table border="1"> <tr> <td>Unmarked angle tolerance</td> <td>± 1</td> </tr> </table>		Unmarked angle tolerance	± 1	Print Edition: A3 First									
Unmarked angle tolerance	± 1												
<table border="1"> <tr> <td>Stage marker</td> <td>S</td> <td>A</td> <td>B</td> </tr> <tr> <td>Weight</td> <td></td> <td></td> <td></td> </tr> </table>		Stage marker	S	A	B	Weight				Drawing scale: 1.5:1			
Stage marker	S	A	B										
Weight													
<table border="1"> <tr> <td>Proportion: 1.5:1</td> <td>No. of pages: 1/1</td> </tr> </table>		Proportion: 1.5:1	No. of pages: 1/1										
Proportion: 1.5:1	No. of pages: 1/1												