

5 DIGITAL MICRO-PROCESS METER

with 2~4 ALARMS / ANALOG OUTPUT / RS-485

AM5H-A

FEATURES

- Accuracy: $\pm 0.1\%$ F.S. ± 1 digit (DC / Potentiometer / Resistor / PT-100 / Load Cell)
 $\pm 0.2\%$ F.S. ± 1 digit (AC)
- Measuring AC, DC Voltage / AC, DC Current / Potentiometer / Resistor / PT-100 / Load Cell
- High brightness 0.8" LED display range: -19999~99999; decimal point selectable
- Display range programmable
- Max. Hold / Data Hold / Reset / 2~4 Alarms (Hi or Lo) programmable / Analog output (15 bit resolution) / RS-485 communication optional (The above options can exist together)
- High stability, non-flammable case (PC), high safety
- CE approval



Fastron CE
Electronics

ORDER INFORMATION: AM5H-A- [Code 1] [Code 2] - [Code 3] - [Code 4] [Code 5] [Code 6]

Code 1	Input Type	Code 2	Voltage	Code 2	Current	Code 2	Potentiometer	Code 2	Resistor	Code 2	RTD (PT-100)	Code 2	Load Cell	Code 3	Aux. Power	Code 5	Analog Output
D	DC	V1	0~50mV	A1	0~20uA	P1	500Ω~10KΩ	I1	0~10Ω	T1	-50~50℃	L1	1mV/V EX.5V	A	AC/DC100~240V	N	None
A	AC AVG	V2	0~5V	A2	0~200uA	P2	10KΩ~100KΩ	I2	0~100Ω	T2	-100~100℃	L2	2mV/V EX.5V	D	AC/DC 22~60V	A	4~20mA
M	AC TRMS	V3	1~5V	A3	0~2mA	P3	100KΩ~1MΩ	I3	0~1KΩ	T3	-200~200℃	L3	3mV/V EX.5V	O	Option	V	0~10V
P	3 Wire Potentiometer	V4	0~10V	A4	0~20mA	PO	Option	I4	0~10KΩ	T4	0~600℃	L4	1mV/V EX.10V			L	Loop Power
I	2 Wire Resistor	V5	0~36V	A5	0~200mA			I5	0~100KΩ	TO	Option	L5	2mV/V EX.10V			L	4~20 mA
T	RTD (PT-100)	V6	0~300V	A6	4~20mA			IO	Option			L6	3mV/V EX.10V			O	Option
L	Load Cell	V7	0~600V	A7	0~2A							LO	Option				
2	2 Wire Sensor	VO	Option	A8	0~5A												
3	3 Wire Sensor			A9	0~10A												
4	4 Wire Sensor			AO	Option												

- **1: 2 wire type offers excitation power DC24V for 2 wire (Loop Power) pressure, temperature, humidity sensors using.
 2: Please specify the input signal and display value, inquiry salespersons for special type.
 3: Load Cell type of excitation power DC5V can have 2 load cell in parallel; DC10V only can offer 1 load cell to use.
 4: 3 Relay type only offers A(Normal/Open) output. O.C. (Open Collect) offers NPN of C.E. output.

SPECIFICATION

- ◆ Accuracy: $\pm 0.1\%$ F.S. ± 1 digit (DC / Potentiometer / Resistor / PT-100 / Load Cell)
 $\pm 0.2\%$ F.S. ± 1 digit (AC)
- ◆ Display Screen: High brightness red LED; 20.3mm(0.8")
- ◆ Sampling Time: 16 cycles / sec
- ◆ Display Range: -19999~99999
- ◆ Zero Adjustment: -19999~99999
- ◆ Over Range Indication: doFL / ioFL or -doFL / -ioFL
- ◆ Polarity Indication: Automatic with "-" indication
- ◆ Parameters Setting: Push buttons
- ◆ Back Up Memory: EEPROM
- ◆ Alarm Action: " \geq (Hi) on" or "< (Lo) on"
- ◆ Alarm Run Delay Time: 0~99 sec
- ◆ Relay Contact: AC 277V / 7A; DC 30V / 7A
- ◆ Analog Output Resolution: 15 bit
- ◆ Output Response Time: <250 msec (0~90%)
- ◆ Output Capability: Voltage Output: <20mA
Current Output: <10V
- ◆ Communication: RS-485 Modbus RTU mode
- ◆ Baud Rate: 38400 / 19200 / 9600 / 4800 bps
- ◆ Temperature Coefficient: 100ppm / °C (0~60℃)
- ◆ Operating Temperature: 0~60℃
- ◆ Operating Humidity: 20~90% RH (non-condensing)
- ◆ Storage Temperature: -10~70℃
- ◆ Storage Humidity: 20~90% RH (non-condensing)
- ◆ Power Supply: AC/DC 100~240V; AC/DC 24~60V
- ◆ Power Consumption: 8.5VA (all functions output)
- ◆ Surge Test: 1.5kVac / 1min (Input / Power)
- ◆ Input Impedence: Voltage: >2V for 20KΩ / V; $\leq 2V$ for >200MΩ
Current: $\geq 0.2A$ at 100mV; <0.2A at 1V

FRONT PANEL & KEY FUNCTIONS

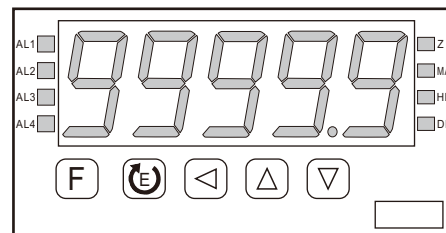

Indicators:
 AL1: Alarm 1 Indicator Z: Reset Indicator
 AL2: Alarm 2 Indicator MAX: Max. Holding Indicator
 AL3: Alarm 3 Indicator HD: Value Holding Indicator
 AL4: Alarm 4 Indicator DIO: Communication Indicator

- F** Reset Key/Tare
- E** Enter Key & Save Key
- ←** Shift Key & Alarm Setting Key
- ↑** Up Key & Value Adjusting Key
- ↓** Down Key & Analog Output Adjusting Key

DIMENSION

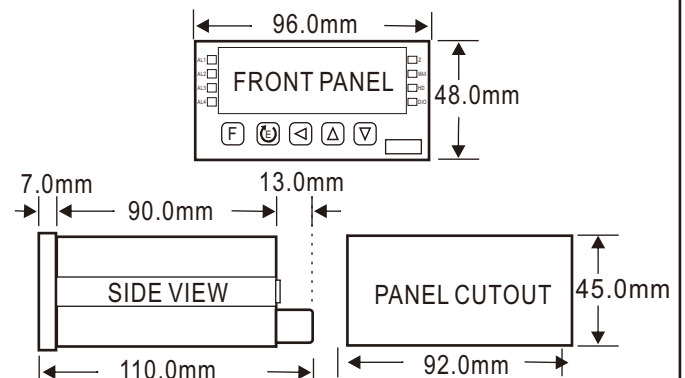

* Please understand key indicators & functions at the first operation.

FRONT PANEL & KEY FUNCTIONS

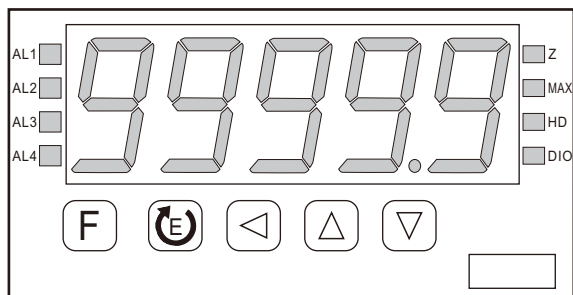

- F** Reset Key/Tare
- E** Enter Key & Save Key
- ←** Shift Key & Alarm Setting Key
- ▲** Up Key & Value Adjusting Key
- ▼** Down Key & Analog Output Adjusting Key

Indicators:

- AL1: Alarm 1 Indicator
- AL2: Alarm 2 Indicator
- AL3: Alarm 3 Indicator
- AL4: Alarm 4 Indicator
- Z: Reset Indicator
- MAX: Max. Holding Indicator
- HD: Value Holding Indicator
- DIO: Communication Indicator

Key Name	Symbol	Descriptions
Reset Key	F	1. Press this key to enable the reset function & reset indicator (F) is light; press this key again to disable the reset function & reset indicator (F) is dark.
Enter Key & Save Key	E	1. In the measuring status, press this key can enter to parameter pages. 2. In the parameter setting, press this key can save the value & go to next parameter.
Shift Key & Alarm Setting Key	←	1. In the measuring status, press this key for 3 sec can enter to alarm setting page (The selecting digit will be flashed) 2. In the parameter setting, press this key can move the cursor left.
Up Key & Display Value Adjusting Key	▲	1. In the measuring status, press this key for 3 sec can enter to display value adjustment of "ZERO" & "SPAN" 2. In the parameter setting, press this key can increase the digits.
Down Key & A/O Adjusting Key	▼	1. In the measuring status, press this key for 3 sec can enter to analog output adjustment. 2. In the parameter setting, press this key can decrease the digits.

- **1. The following block charts are parameters codes, parameter codes & parameters will alternate flashing if the parameters can be modified.
2. To modify the parameters, please press **←**/**▲**/**▼**, and press **E** to save the parameter after the modification.
3. Please don't forget the new pass code after modification.
4. In any pages, press **▲** & **▼**, or don't press any keys for 2 minutes that will back to measuring status.

GENERAL MODE OPERATING PROCEDURES

Block Charts	Display	Descriptions	Default
Power ON	10000	Measuring Status	Present value for measurement
Press ← for 3 sec	AL 1	Alarm 1 Setpoint (AL1)	Modify alarm 1 setpoint. 00000
Press E	AL 2	Alarm 2 Setpoint (AL2)	
Press E	AL 3	Alarm 3 Setpoint (AL3)	
Press E	AL 4	Alarm 4 Setpoint (AL4)	
Display: "ZERO" & "SPAN" Adjustment			
Power ON	10000	Measuring Status	Present value for measurement.
Press ▲ for 3 sec	dZEro	Display Zero Adjustment (dZEro)	Modify the zero value. PS: To use this function to adjust the real zero value. 00000
Press E	dSPANn	Display Span Adjustment (dSPAN)	Modify the span value. PS: To use this function to adjust the real span value. 00000
Analog Output: "ZERO" & "SPAN" Adjustment			
Power ON	10000	Measuring Status	The following steps are only available for analog output.
Press ▼ for 3 sec	AZEro	A/O Zero Adjustment (AZEro)	Modify the A/O zero. PS: To use this function to adjust the real A/O zero. 00000
Press E	ASPAAn	A/O Span Adjustment (ASPAAn)	Modify the A/O span. PS: To use this function to adjust the real A/O span. 00000

- Remark: 1. There are 3 parameter groups of "System Setting Group(SYS)", "Alarm Setting Group(roP)", "Analog Output Setting Group (AoP)", "RS485 Setting Group(doP)" for modification.
2. Press **←** to select each group page, and press **E** to enter each group or parameter page for modification or saving the parameters.
3. Some of optional functions of parameter pages still exist, but the functions are disable.

PROGRAMMING MODE OPERATING PROCEDURES

Block Charts	Display	Descriptions	Default
Power On	10000	Measuring Status	Present value for measurement
Press E	P.Cod	Pass Code (P.Cod)	Enter the pass code, or press E again if no pass code. 00000
Press E	P.Code Correct	P.Code Correct	Pass code is correct that will enter to parameter groups; Pass code is wrong that will back to measuring status.
NO			
YES	SYS	System Setting Group (SYS)	
Press ←	roP	Alarm Setting Group (roP)	
Press ←	AoP	A/O Setting Group (AoP)	
Press ←	doP	RS485 Setting Group (doP)	

Display	Descriptions	Default
System Setting Group Procedures		
595 Press (⊙) ↓ dP	Decimal Point Setting (dP) Select decimal point (0, 1, 2, 3, 4). EX: if the value shows "0.00" that means the decimal point is 2 digits.	Customers specify
Press (⊙) ↓ dSPL	Display Low Scale Setting (dSPL) Modify display low scale for the input signal zero value. EX: If the input signal is 4~20mA; 4mA is shown display 0.00, this parameter must be set for 000.00.	Customers specify
Press (⊙) ↓ dSPH	Display Hi Scale Setting (dSPH) Modify display high scale for the input signal span value. EX: If the input signal is 4~20mA; 20mA is shown display 100.00, this parameter must be set for 100.00.	Customers specify
Press (⊙) ↓ AvG	Display Average Setting (AvG) Modify display average (1~99). PS: Please use this function for stable display value when input signal is unstable.	00005
Press (⊙) ↓ LCuT	Display Low Cut Setting (LCuT) Modify display low cut to 0 (0~99).	00000
Press (⊙) ↓ CodE	Pass Code Setting (CodE) Modify pass code (0~19999). PS: Please don't forget the new pass code after modification.	00000
Press (⊙) ↓ di	Control DI Setting (di) Select control DI off (YES) or on (NO). PS: Control DI (Z, MAX, HD) & (COM) shorts, the functions starts.	no
Press (⊙) ↓ LoCK	Key Lock Setting (LoCK) Lock the keys, using key lock function only can view the parameters, but cannot modify any values. PS: no (unlock), YES ("ENT" unlock, others lock).	no
Alarm Setting Group Procedures		
Alarm Setting Page (roP) The following steps are only available for alarm output.		
Press (⊙) ↓ roP Act1 Act2 Act3 Act4	Alarm Action Setting Modify alarm value that is \geq (Hi) or $<$ (Lo) for alarm action.	Hi
Press (⊙) ↓ HYS1 HYS2 HYS3 HYS4	Alarm Hysteresis Setting Modify the value, when alarm runs lower or higher display value (depends on alarm action). Alarm setpoint \pm this range (0~999) will turn off the alarm.	00000
Press (⊙) ↓ dEL1 dEL2 dEL3 dEL4	Alarm Run Delay Setting Modify the value, when the display value reach the alarm value that need to wait for this time (0~99 sec) for alarm action.	00000
Press (⊙) ↓ Sb	Alarm Start Band Setting (Sb) Modify the value (-99~+99), if the display value don't over this range; the alarm will not be act.	00000
Press (⊙) ↓ Sdt	Alarm Start Band Time Setting (Sdt) Modify the value (0~99 sec), if the display value reach alarm start band value; the alarm will be act after this value (sec). (The function is used with "Sb" function.)	00000

Display	Descriptions	Default
A/O Setting Group Procedures		
A/O Setting Page (AoP) The following steps are only available for analog output.		
Press (⊙) ↓ roP PoLARr	A/O Polarity Setting (PoLARr) Select output for positive or negative pole. PS: Voltage output, NO: positive pole output (0~+10V) YES: positive & negative pole output (-10~+10V)	no
Press (⊙) ↓ AnLo	A/O Low Scale Setting (AnLo) Adjust A/O low scale to correspond to the display value. EX: A/O is 0~10V, the display is 10.0 to output 0V, this value must be set for 10.0.	00000
Press (⊙) ↓ AnHi	A/O Hi Scale Setting (AnHi) Adjust A/O hi scale to correspond to the display value (programmable). EX: A/O is 0~10V, the display is 90.0 to output 10V, this value must be set for 90.0.	99999
RS485 Setting Group Procedures		
RS485 Setting Page (doP) The following steps are only available for RS-485.		
Press (⊙) ↓ doP Addr	Address Setting (Addr) Modify address (0~255).	00000
Press (⊙) ↓ bAUd	Baud Rate Setting (bAUd) Select baud rate (38400/19200/9600/4800).	19200
Press (⊙) ↓ PARr	Parity Setting (PARr) Select parity (n.8.2/n.8.1/even/odd).	n.8.2
Press (⊙) ↓ FrAnE	Frame Setting (FrAnE) Select frame type. (NO:Hi→Lo, YES:Lo→Hi)	no

Error Code of Self-Diagnosis	
Display	Descriptions
1 oFL	Input signal is over 120% of input range.
-1 oFL	Input signal is under -20% of input range.
AdEr	Input signal is over 180% of input range or meter error.
doFL	Input signal is over display range (99999)
-doFL	Input signal is under display range (-19999)
E-00	EEPROM reading/writing suffers the interference (about 1 million times).

**Please check the wiring connection is correct first, if the problem still exist, please return the meter to the factory.



Modbus RTU Mode Protocol Address Table

Data: 16Bit/32Bit, +/- is 8000~7FFF (-32768~32767), 80000000~7FFFFFFF (-2147483648~2147483647)

Modbus	HEX	Name	Descriptions	Act
40001	0000	ID	Model number identification; AM5H-A is "00"	R
40002	0001	STATUS	Current alarm output & external control input status display; range: 0000~00FF (0~254) (0:OFF, 1:ON) (Bit7:AL4, Bit6: AL3, Bit5: AL2, Bit4: AL1, Bit3:HD, Bit2:MAX, Bit1:AZ)	R
40003	0002	FUNC	Parameters setting; range: 0000~00FF (0~255) Bit0~3: ACT1~4 (0:HI, 1:LO), Bit4:CON, Bit5:POLAR	R/W
40004	0003	DP	Decimal point setting; range: 0000~0004 (0~4) 0:10 ⁰ , 1:10 ⁻¹ , 2:10 ⁻² , 3:10 ⁻³ , 4:10 ⁻⁴	R/W
40005	0004	BAUD	Baud rate setting; range: 0000~0003 (0~3) 0:38400, 1:19200, 2:9600, 3:4800	R/W
40006	0005	PARI	Parity setting; range: 0000~0003 (0~3), 0:N.8.2., 1:N.8.1., 2:EVEN, 3:ODD	R/W
40007	0006	AVG	Display average setting; range: 0001~0063 (1~99)	R/W
40008	0007	LCUT	Display low cut setting; range: 0000~0063 (0~99)	R/W
40009	0008	ADDR	Address setting; range: 0000~00FF (0~255)	R/W
40010	0009	DEL1	Alarm 1 act delay time setting; range: 0000~0063 (0~99)	R/W
40011	000A	DEL2	Alarm 2 act delay time setting; range: 0000~0063 (0~99)	R/W
40012	000B	DEL3	Alarm 3 act delay time setting; range: 0000~0063 (0~99)	R/W
40013	000C	DEL4	Alarm 4 act delay time setting; range: 0000~0063 (0~99)	R/W
40014	000D	SB	Alarm start band setting; range: FF9D~0063 (-99~99)	R/W
40015	000E	SDT	Alarm start delay time setting; range: 0000~0063 (0~99)	R/W
40016	000F	HYS1	Alarm 1 hysteresis setting; range: 0000~270F (0~9999)	R/W
40017	0010	HYS2	Alarm 2 hysteresis setting; range: 0000~270F (0~9999)	R/W
40018	0011	HYS3	Alarm 3 hysteresis setting; range: 0000~270F (0~9999)	R/W
40019	0012	HYS4	Alarm 4 hysteresis setting; range: 0000~270F (0~9999)	R/W
40020	0013	CODE	Pass code setting; range: 0000~4E1F (0~19999)	R/W
40021	0014	AZERO	Analog output zero setting; range: D8F1~270F (-9999~9999)	R/W
40022	0015	ASPAN	Analog output span setting; range: D8F1~270F (-9999~9999)	R/W
40023	0016	DSPL	Display low scale setting; range: FFFFB1E1~0001869F(-19999~99999) Hi Bit	R/W
40024	0017		Display low scale setting; range: FFFFB1E1~0001869F(-19999~99999) Low Bit	R/W
40025	0018	DSPH	Display hi scale setting; range: FFFFB1E1~0001869F(-19999~99999) Hi Bit	R/W
40026	0019		Display hi scale setting; range: FFFFB1E1~0001869F(-19999~99999) Low Bit	R/W
40027	001A	AL1	Alarm 1 setpoint setting; range: FFFFB1E1~0001869F(-19999~99999) Hi Bit	R/W
40028	001B		Alarm 1 setpoint setting; range: FFFFB1E1~0001869F(-19999~99999) Low Bit	R/W
40029	001C	AL2	Alarm 2 setpoint setting; range: FFFFB1E1~0001869F(-19999~99999) Hi Bit	R/W
40030	001D		Alarm 2 setpoint setting; range: FFFFB1E1~0001869F(-19999~99999) Low Bit	R/W
40031	001E	AL3	Alarm 3 setpoint setting; range: FFFFB1E1~0001869F(-19999~99999) Hi Bit	R/W
40032	001F		Alarm 3 setpoint setting; range: FFFFB1E1~0001869F(-19999~99999) Low Bit	R/W
40033	0020	AL4	Alarm 4 setpoint setting; range: FFFFB1E1~0001869F(-19999~99999) Hi Bit	R/W
40034	0021		Alarm 4 setpoint setting; range: FFFFB1E1~0001869F(-19999~99999) Low Bit	R/W

Modbus	HEX	Name	Descriptions	Act
40035	0022	ANLO	Analog output low scale setting; range: FFFFB1E1~0001869F (-19999~99999) Hi Bit	R/W
40036	0023		Analog output low scale setting; range: FFFFB1E1~0001869F (-19999~99999) Low Bit	R/W
40037	0024	ANHI	Analog output hi scale setting; range: FFFFB1E1~0001869F (-19999~99999) Hi Bit	R/W
40038	0025		Analog output hi scale setting; range: FFFFB1E1~0001869F (-19999~99999) Low Bit	R/W
40039	0026	DISPLAY	Current display; range: FFFFB1E1~0001869F (-19999~99999) Hi Bit	R
40040	0027		Current display; range: FFFFB1E1~0001869F (-19999~99999) Low Bit	R
40041	0028	INLO	Input low calibrated value display; range: 00029F16~004EA4A8 (171798~5153960) Hi Bit	R
40042	0029		Input low calibrated value display; range: 00029F16~004EA4A8 (171798~5153960) Low Bit	R
40043	002A	INHI	Input hi calibrated value display; range: 00029F16~004EA4A8 (171798~5153960) Hi Bit	R
40044	002B		Input hi calibrated value display; range: 00029F16~004EA4A8 (171798~5153960) Low Bit	R
40045	002C	MAX	Max. hold display; range: FFFFB1E1~0001869F (-19999~99999) Hi Bit	R
40046	002D		Max. hold display; range: FFFFB1E1~0001869F (-19999~99999) Low Bit	R
40047	002E	HOLD	Data hold display; range: FFFFB1E1~0001869F (-19999~99999) Hi Bit	R
40048	002F		Data hold display; range: FFFFB1E1~0001869F (-19999~99999) Low Bit	R
40049	0030	AZ	Auto zero; range: FFFFB1E1~0001869F (-19999~99999) Hi Bit	R
40050	0031		Auto zero; range: FFFFB1E1~0001869F (-19999~99999) Low Bit	R

CALIBRATION OPERATING PROCEDURES

Display	Descriptions	Default
10000	Measuring Status	Calibration operating procedures.
inLo	Input Low Scale Calibration (inLo)	1. Input standard low scale signal. 2. Press  to calibrate input low scale.
inHi	Input Hi Scale Calibration (inHi)	1. Input standard hi scale signal. 2. Press  to calibrate input hi scale.
SYS	System Setting Page(SYS)	1. Finish calibration operating procedures will enter to system setting group. 2. Press  to back to measuring status.

Warning: Calibration of this meter requires a standard signal with 0.01% accuracy or better and an external meter with 0.005% accuracy or better.



- Power Semiconductors
- Electrical Measurement
- Process Control

9B Lakewood Blvd
Braeside VIC 3195 Australia

Web: www.fastron.com.au
Email: sales@fastron.com.au
Telephone: + 61- 3 - 97635155
Facsimile: + 61- 3 - 97635206