

# PointSenz PCM 10-PR/SP1

$$I_{PN} = 10 A$$

PointSenz PCM 10-PR/SP1 is optimised for the electronic measurement of AC currents, with a galvanic isolation between the primary (high power) circuit and the secondary (electronic) circuit.

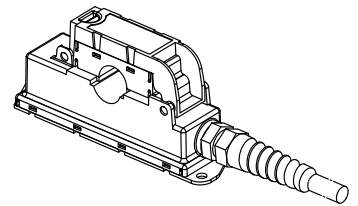

## Electrical data

$I_{PN}$	Primary nominal RMS current	10	A
$I_{PM}$	Primary current, measuring range	0 ... $\pm 30$	A
$I_{out}$	Analogue output current @ $I = 0$	4	mA
$I_{out}$	Analogue output current @ $I_{PN}$	12	mA
$I_{out}$	Analogue output current @ $2 \times I_{PN}$	20	mA
$R_M$	Measuring resistance	100 ... 500	$\Omega$
$U_C$	Supply voltage <sup>1)</sup> ( $\pm 10\%$ )	+24	V
$I_{Cmax}$	Maximum current consumption <sup>2)</sup>	50	mA

## Accuracy - Dynamic performance data

		Typ	
$X$	Accuracy <sup>3)4)</sup> @ $T_A = +25^\circ C$ , $U_C = +24 V$ , $f = 50 Hz$	$\pm 2$	% of $I_P$
	Position sensitivity relative to centre reading (max)	$\pm 1.5$	% of $I_P$
$\epsilon_L$	Linearity error <sup>4)</sup>	$\pm 1.0$	% of $I_P$
$I_O$	Offset current @ $I_P = 0$ , $T_A = 25^\circ C$ (max)	$+ 4 \pm 0.3$	mA
$TCI_{OE}$	Temperature coefficient of $I_{OE}$ $T_A = +5 \dots +50^\circ C$	$\pm 0.03$	mA/ $^\circ K$
$TCG$	Temperature coefficient of $G$ , $T_A = +5 \dots +50^\circ C$	$\pm 0.10$	%/ $^\circ K$
$t_r$	Step response time to 90 % of $I_{PN}$	50	ms
$BW$	Frequency bandwidth (-3 dB)	0.040 ... 1	kHz

## General data

$T_A$	Ambient operating temperature	-25 ... +55	$^\circ C$
$T_S$	Ambient storage temperature	-25 ... +85	$^\circ C$
	Relative humidity $T_A = 40^\circ C$	95	%
$m$	Mass	155	g
	Standards	EN 50155: 1995 EN 50121-4: 2001 EN 50121-3-2: 2015 <sup>5)</sup>	

Notes: <sup>1)</sup>Reverse polarity protection

<sup>2)</sup>Including  $I_{out}$

<sup>3)</sup>Excludes electrical offset

<sup>4)</sup>Includes linearity with the conductor in the centre of the aperture

<sup>5)</sup>Deviation of the offset during the test IEC 61000-4-3 @ 20V/m between 500 MHz and 1 GHz

## Features

- Closed loop (compensated) current transducer using the Hall effect
- Panel mounting
- Split core design for easy installation
- Insulating plastic case to UL 94-V0
- Reverse polarity protected.

## Advantages

- Very good linearity
- Excellent accuracy
- Current overload capability
- No insertion losses
- Non - contact measurement (does not need a safety case).

## Applications

- Points condition monitoring
- Signal light indication
- Battery supplied applications
- Uninterruptable Power Supplies (UPS).

## Application Domain

- Track Side.

## Current Transducer PCM 10-PR/SP1

### Isolation characteristics

$U_b$	Rated isolation voltage RMS <sup>5)</sup>	200 Min	V
$d_{cp}$	Creepage distance	12	mm
$d_{ci}$	Clearance	10	mm
$CTI$	Comparative Tracking Index (group IIIa)	175	

Note: <sup>5)</sup> Overvoltage category II, Pollution degree 2.

### Safety



This transducer must be used in electric/electronic equipment with respect to applicable standards and safety requirements in accordance with the manufacturer's operating instructions.



Caution, risk of electrical shock

When operating the transducer, certain parts of the module can carry hazardous voltage (eg. primary busbar, power supply).

Ignoring this warning can lead to injury and/or cause serious damage.

This transducer is a built-in device, whose conducting parts must be inaccessible after installation.

A protective housing or additional shield could be used.

Main supply must be able to be disconnected.

## Dimensions PCM 10-PR/SP1 (in mm. 1 mm = 0.0394 inch)

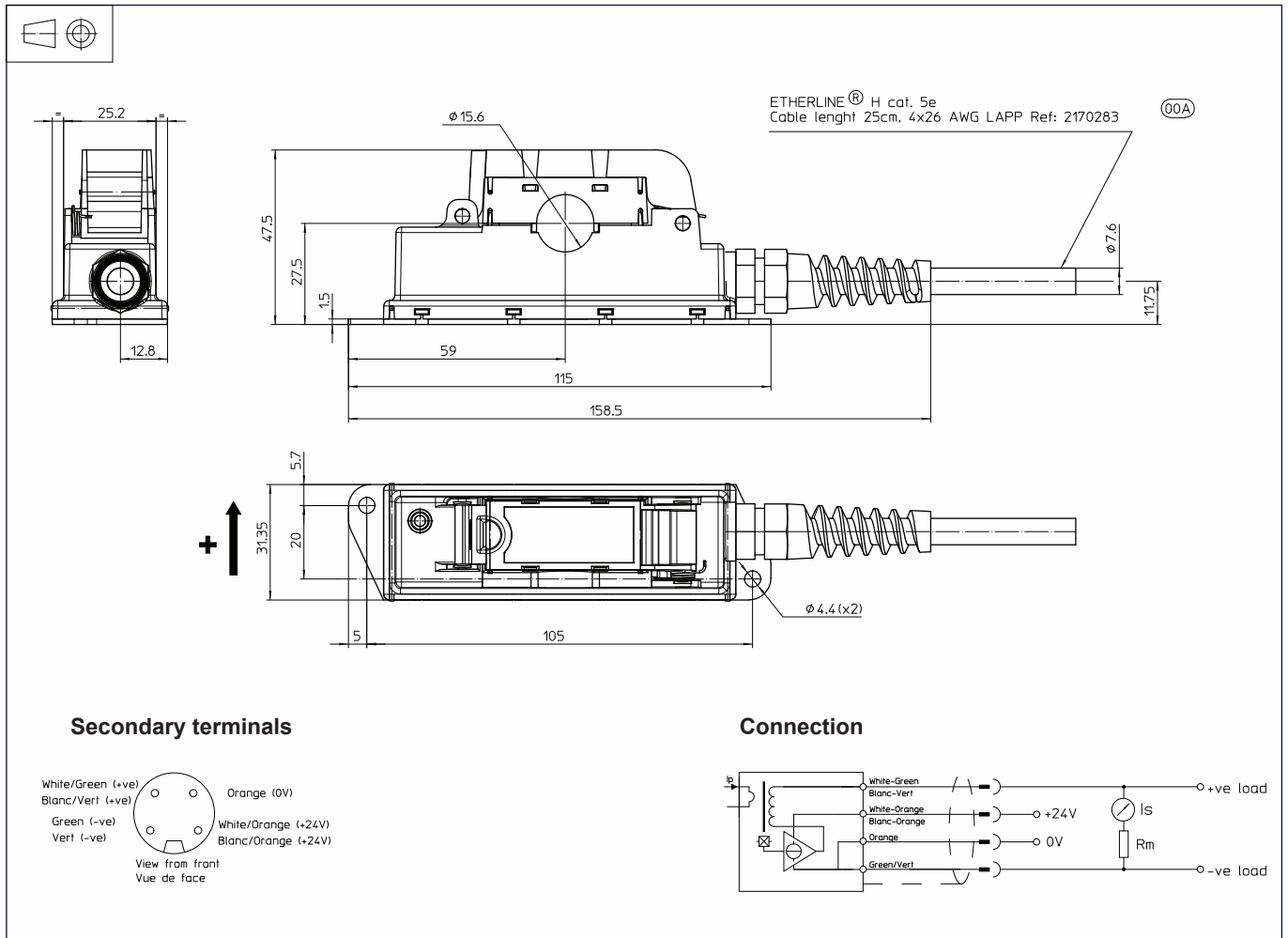

### Mechanical characteristics

- General tolerance ±0.5 mm
- Primary through-hole Ø 15 mm
- Connection of secondary Via a 4 core screened Unitronic Etherline H-Flex CAT 5, Lapp number 2170283 length of 0.25 m. Terminated by a male, miniature circular 4 pin connector with a shielding ring series 423. Binder number 99-5109-15-04
- Enclosure UL 94-V0 rated plastic

### Remarks

- $I_{out}$  is positive when  $I_p$  flows in the direction of the arrow.
- Temperature of the primary conductor should not exceed 90°C.
- This unit is intended for direct mounting in trackside applications. It should only be installed or removed from isolated hazardous live conductors or unisolated hazardous live conductors which are switched off.
- Connections between the transducer and the customers power supply and output monitoring equipment should be made with screened cable.