



# Mounting Instructions / Manual

## MV1171



## POWER FACTOR Controller

### ESTAmat MH-N



---

## **1. INTRODUCTION**

- 1.1 About the User Manual**
- 1.2 Precautions for Safe Use and Installation**

## **2. GENERAL**

## **3. FRONT PANEL SPECIFICATIONS**

- 3.1 Buttons and Lights**

## **4. CONNECTION DIAGRAM**

## **5. CONTROLS AND MENU OPERATIONS**

- 5.1 Selection of the Operating Mode (Automatic / Manual Mode )**
  - 5.1.1 Switching of the Capacitor Steps Manually**
- 5.2 Automatic C/k Adjustment**
- 5.3  $\cos\phi$  Adjustment**
- 5.4 Step Time Adjustment**
- 5.5 Step Number Selection**
- 5.6 Switching Program Selection**
- 5.7 Selection of C/k Value by the User**
- 5.8 Selection of Current Transformer Primary Value**
- 5.9 Protection of Capacitor Steps Against Overvoltage**
- 5.10 Display of the  $\cos\phi$  Value**
- 5.11 Display of the Power Factor (PF) Value**
- 5.12 Displaying the Voltage and Current RMS Values**
- 5.13 Display of the Active Power (W) Value**
- 5.14 Display of the Reactive Power (VAR) Value**
- 5.15 Display of the Apparent Power (VA) Value**

## **6. DESCRIPTION**

- 6.1 Errors and Warnings**
  - 6.1.1 Overvoltage**
  - 6.1.2 Insufficient Compensation**
  - 6.1.3 Overcompensation**
- 6.2 Target  $\cos\phi$**
- 6.3 Adjustable Step Switching Time**
- 6.4 Switching Program Selection**
  - 6.4.1 ESTAmat MH-N Capacitor Sequence Examples**
- 6.5 Step Number Selection**
- 6.6 C/k Setting**
- 6.7 Determine the Energy Flow Direction**
- 6.8 Current Transformer (CT) Selection**

## **7. ERROR DESCRIPTIONS**

- 7.1 Wrong  $\cos\phi$**
- 7.2 Insufficient Compensation**
- 7.3 Overcompensation**
- 7.4 Overvoltage**

## **8. EASY INSTALLATION RECOMMENDATION (IMPORTANT NOTICE)**

## **9. TECHNICAL SPECIFICATIONS**

## **10. DIMENSIONS**



## 1. INTRODUCTION

### 1.1 About the User Manual

This user manual is intended for fast installation of the ESTAmat MH-N. Before installation and operation please read these chapters very carefully.

### 1.2 Precautions for Safe Use and Installation

- 1) Maintenance, installation and operation of the ESTAmat MH-N only to be done by qualified persons.
- 2) Disconnect power before working on the equipment.
- 3) Do not operate the ESTAmat MH-N at voltage too low (“undervoltage” condition)
- 4) Do not open the ESTAmat MH-N’s housing. There are no user servicable parts inside it.
- 5) The ESTAmat MH-N is connected to the network by means of a current transformer. Do not disconnect the terminals of the current transformer. If required to disconnect, then make sure to short-circuit the secondary side of the current transformer or to connect to another parallel load having sufficiently low impedance.  
In case of failure, dangerous high voltage at the secondary side of the current transformer may cause an electric shock.
- 6) Do not use this product for any other purpose than its original.
- 7) Once the device is connected to the network, do not remove the front panel.
- 8) Do not clean the device with solvent or similar. Clean only with a dry cloth.
- 9) Verify correct terminal connections when wiring.
- 10) Electrical equipment should be serviced only by your competent seller.
- 11) Only for rack panel mounting.
- 12) No responsibility is assured by **the manufacturer** or any of its subsidiaries for any consequences rising out of the use of this material.

## 2. GENERAL

Power factor controllers are used for measurement and control of power factor control units for central reactive power compensation. The ESTAmat MH-N compares the measured power factor with the set point value (target value) and in order to provide the required compensation, the power factor controller will automatically switch capacitor steps ON or OFF.

The ESTAmat MH-N is a microprocessor controlled relay, designed for above application in 144x144 casing for flush mounting with rear plug-in connectors. In addition to displaying the system’s  $\cos\phi$  in the automatic operating mode, the ESTAmat MH-N also displays the RMS value of voltage (V), current (I), active power (W), reactive power (VAR) and apparent power (VA) of the measuring phase.

### 3. FRONT PANEL SPECIFICATIONS

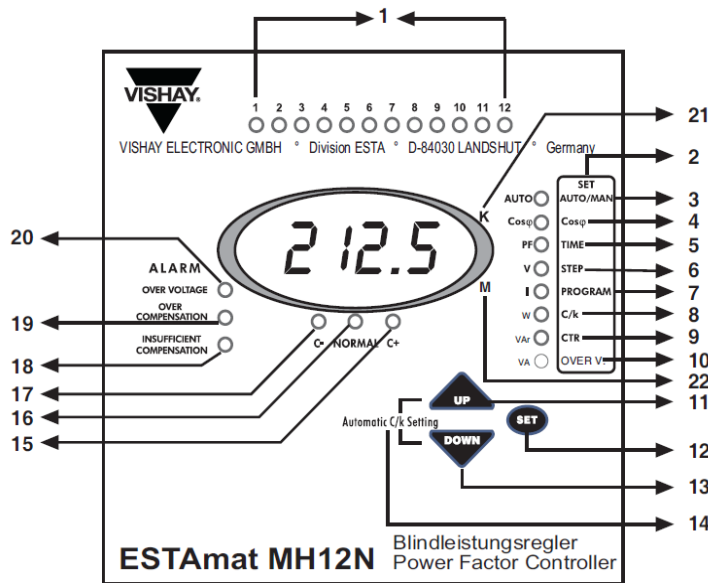

On the front panel of the ESTAmat MH-N, there are warning lights, the display and 3 buttons for settings.

#### 3.1 Buttons and Lights

1, 2 ,.....,12 : Shows the status of each capacitor step.

2. SET menu : Shows the menu options, corresponding to the light.

3. AUTO/MAN Light : As long as this light is continuously ON, the ESTAmat MH-N is in the automatic mode.

If it is blinking, then the ESTAmat MH-N is in the manual mode. By pressing the SET button for 3 seconds, the menu is entered to change the operating mode. **(Refer to: 5.1)**

4.  $\cos\phi$  Light : By pressing the SET button for 3 seconds, the  $\cos\phi$ -adjustment can be made by selecting this light. **(Refer to: 5.3)**

In the automatic mode, when the  $\cos\phi$  light is selected by pressing the UP or DOWN button, the system's  $\cos\phi$  and ind/cap status will be displayed. **(Refer to: 5.10)**

5. TIME/PF Light : By pressing the SET button for 3 seconds the menu is entered and step time adjustment is made by selecting this light. **(Refer to: 5.4)**

In the automatic mode, when this light is selected by pressing the UP or DOWN button, the system's power factor is displayed. **(Refer to: 5.11)**

6. STEP/V Light : By pressing the SET button for 3 seconds the menu is entered and the step number adjustment is made by selecting this light. **(Refer to:5.5)**

In the automatic mode, when this light is selected by pressing the UP or DOWN button, the phase voltage (V) is displayed. **(Refer to:5.12)**

7. PROGRAM/I Light: By pressing the SET button for 3 seconds the menu is entered and the power sequence adjustment is made by selecting this light. **(Refer to:5.6)**

In the automatic mode, when this light is selected by pressing the UP or DOWN button the phase current (I) is displayed **(Refer to:5.12)**

8. C/k - W Light : By pressing SET button for 3 seconds the menu is entered and the manual C/k adjustment is made by selecting this light. **(Refer to:5.7)**

In the automatic mode when this light is selected by pressing the UP or DOWN button, the system's active power (W) is displayed. **(Refer to: 5.13)**

9. CTR - VAr Light : By pressing the SET button for 3 seconds the menu is entered and the current transformer ratio adjustment is made by selecting this light. **(Refer to:5.8)**

In the automatic mode when this light is selected by pressing the UP or DOWN button, the system's reactive power (VAr) is displayed. **(Refer to: 5.14)**

10. Over V. /VA Light : By pressing the SET button for 3 seconds, the menu is entered and the protection of the capacitor steps against overvoltage is made by selecting this light. **(Refer to: 5.9)**  
In the automatic mode when this light is selected by pressing the UP or DOWN button, the system's apparent power (VA) is displayed. **(Refer to: 5.15)**
11. UP Button : To move up in the menu.
12. SET Button : Enter button for different settings.
13. DOWN Button : To move down in the menu.
14. Automatic C/k Setting : automatical C/k adjustment is started by pressing the UP/DOWN buttons simultaneously. **(Refer to: 5.2)**
15. C+ Light : This light is ON when the ESTAmat MH-N is switching capacitor steps on.
16. NORMAL Light : This light is ON when the target compensation is achieved.
17. C- Light : This light is ON when the ESTAmat MH-N is switching capacitor steps off.
18. Insufficient Compensation Light : This warning light is ON when compensation is insufficient. **(Refer to: 6.1.2)**
19. Overcompensation Light : This warning light is ON when overcompensation occurs. **(Refer to: 6.1.3)**
20. Overvoltage light : This warning light is ON when overvoltage occurs. **(Refer to: 6.1.1)**
21. K (Kilo) Light : When this light is ON, the displayed value must be multiplied by 1000.
22. M (Mega) Light : When this light is ON, the displayed value must be multiplied by 106.

#### 4. CONNECTION DIAGRAM

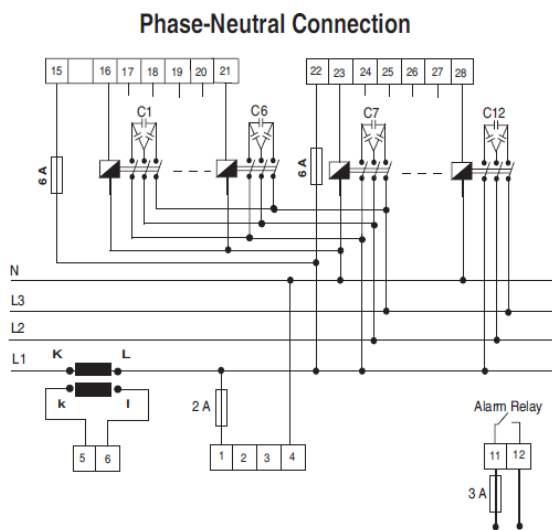

#### Warnings:

- a) Connection of a circuit breaker is highly recommended between the network and the power supply input of the device.
- b) Circuit breaker must be close to the device.
- c) Circuit breaker must be marked as a disconnecting device for the equipment.
- d) All used fuses must be of FF type and the current values of the fuses must be 2A, 3A and 6A.



## **5. CONTROLS AND MENU OPERATIONS**

All settings are made by the menu. The set values, except of the operating mode, are memorized even when the device is switched off. When switched on, the controller starts the compensation by the values as memorized for the automatic operating mode. After entering the menu by pressing the SET button for 3 seconds and if no adjustments are done for 20 seconds, then the ESTAmat MH-N operates with the values memorized before.

To quit the menu without memorizing any changes, press the UP or DOWN button  $\updownarrow$ , until the ESC symbol is displayed. Then press the SET button.

The details on controls and adjustments are explained in the following sections.

### 5.1 Selection of the Operating Mode (Automatic / Manual Mode)

Two operating modes are valid for switching on/off of the capacitor steps.

- 1) The automatic operating mode: The capacitor steps are automatically controlled by the ESTAmat MH-N.
  - 2) The manual operating mode: the capacitor steps are manually switched on/off.
- The mode selection is done as followed.

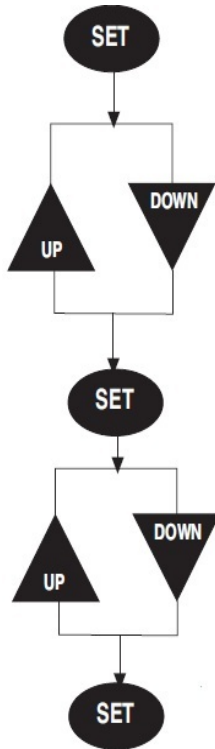

By pressing the SET button for 3 seconds, the SET menu is started.

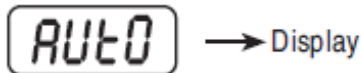

The AUTO/MAN light is selected by using the UP/DOWN buttons. The symbol is displayed.

The AUTO/MAN setting is selected by pressing the SET button.

When the device is in the **manuel** mode, *A O F* symbol is displayed.

When the device is in the **automatic** mode, *A O n* symbol is displayed.

The automatic mode (*A O n*) or the manual mode (*A O F*) is selected by using the UP or DOWN button.

Once the required operating mode is displayed, it is selected by pressing the SET button. When the manual mode is selected, the AUTO/MAN light starts and keeps on blinking during this mode. When the automatic mode is selected, the AUTO/MAN light is continuously ON during this mode.

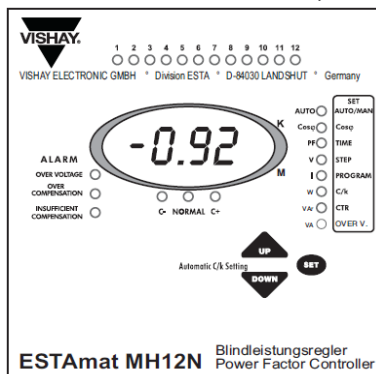

### 5.1.1 Switching of the Capacitor Steps Manually

When the ESTAmat MH-N is in the manual mode, the capacitor steps are connected by pressing the UP button.

Each time the UP button is pressed, the C+ light is ON and one step is connected accordingly.

The NORMAL light will be ON after the connection of the step. This operation must be repeated to connect more steps.

The capacitor steps are disconnected by pressing the DOWN button. Each time the UP button is pressed, the C- light is ON and one step is disconnected after a delay time. The NORMAL light will be ON after the disconnection of the step. This operation must be repeated to disconnect more steps.

### 5.2 Automatic C/k Adjustment



C/k adjustment is started by pressing the UP/DOWN buttons simultaneously.

### 5.3 Cosφ Adjustment

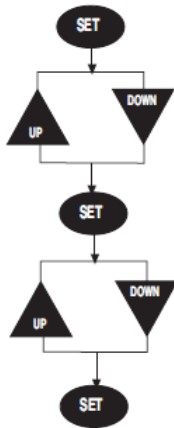

By pressing the SET button for 3 seconds, the SET menu is started.

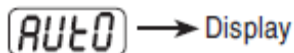

The Cosφ light is selected by using the UP/DOWN buttons. The **COS** symbol is displayed.

The Cosφ adjustment is selected by pressing the SET button. The previously adjusted value is shown on the display. A value between 0.85-1.00 can be adjusted by using the UP or DOWN button. Once the target value is displayed, it is memorized by pressing the SET button and the ESTAmat MH-N returns to its normal operating mode.

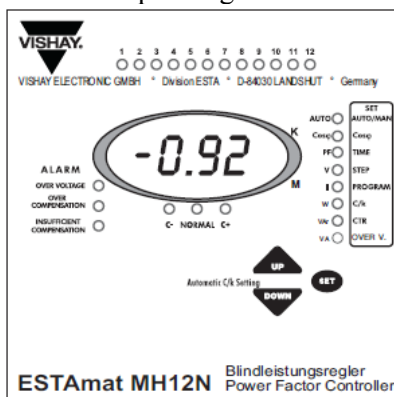



### 5.4 Step Time Adjustment

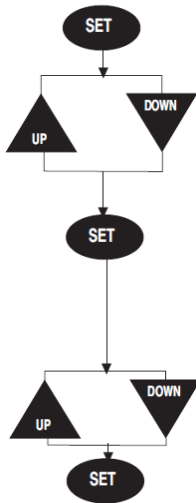

By pressing the SET button for 3 seconds, the SET menu is started.

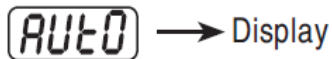

The TIME light is selected by means of the UP/DOWN buttons.

While the TIME light is ON, the  $t_{on}$  symbol is displayed by means of the UP or DOWN button and the time delay adjustment for connection of the capacitor steps is selected by pressing the SET button.

While the TIME light is ON, the  $t_{off}$  symbol is displayed by means of the UP or DOWN button and the time delay adjustment for disconnection of capacitor steps to system is selected by pressing the SET button.

A value between 2-1800 sec. is adjusted by using the UP or DOWN button.

Once the target value is displayed it is memorized by pressing SET button, and the ESTAmat MH-N returns to its normal operating mode.

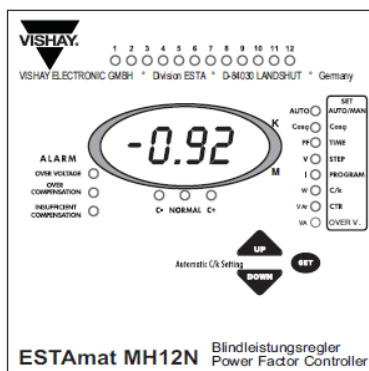

### 5.5 Step Number Selection

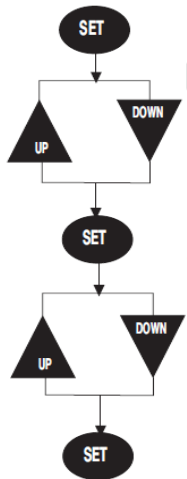

By pressing the SET button for 3 seconds the SET menu is started.



The STEP light is selected by means of the UP/DOWN buttons. The **STEP** symbol is displayed. The STEP number adjustment is selected by pressing the SET button. The previously selected value is shown on the display.

A preferred step number is selected by means of the UP or DOWN button.

Once the target value is displayed, it is memorized by pressing the SET button, and the ESTAmat MH-N returns to its normal operating mode.

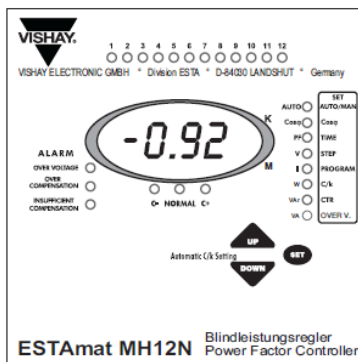

## 5.6 Switching Program Selection

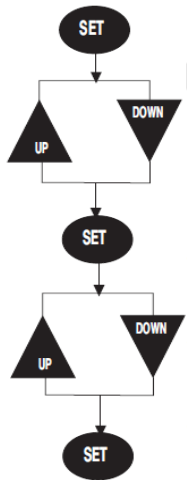

By pressing the SET button for 3 seconds the SET menu is started.



The PROGRAM light is selected by means of the UP/DOWN buttons. The *Prog* (program) symbol is displayed.

The switching program is selected by pressing the SET button. The previously selected value is shown on the display.

A value between PS1-PS5 can be selected by using the UP or DOWN button.

Once the target program is displayed, it is memorized by pressing the SET button, and the ESTAmat MH-N returns to its normal operating mode.

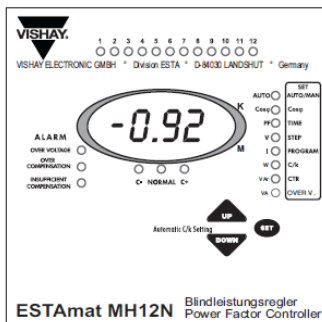

### 5.7 Selection of C/k Value by the User

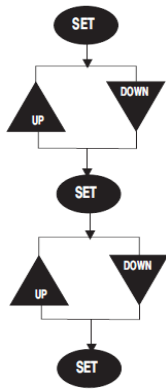

By pressing the SET button for 3 seconds the SET menu is started.



The C/ k light is selected by means of the UP/DOWN buttons. The  $\epsilon$  symbol is displayed.

The manual C/ k adjustment is selected by pressing the SET button. The previous C/ k value, either manually selected or automatically calculated, is shown on the display.

A value between 0.02-1 is selected by using the UP or DOWN button.

Once the target value is displayed, it is memorized by pressing the SET button, and the ESTAmat MH-N returns to its normal operating mode.

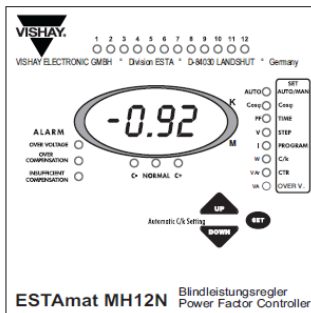

### 5.8 Selection of Current Transformer Primary Value

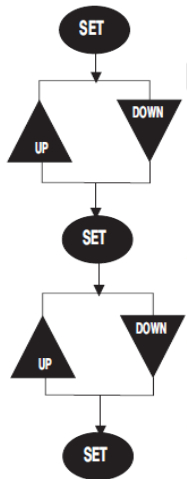

By pressing the SET button for 3 seconds the SET menu is started.



The CTR light is selected by means of the UP/DOWN buttons. The  $\square$  symbol is displayed. The current transformer's primary value is selected by pressing the SET button. The previously selected CTR value is shown on the display. A value between 5-10000 can be adjusted by using the UP or DOWN button. Once the target value is displayed, it is memorized by pressing the SET button, and the ESTAmat MH-N returns to its normal operating mode.

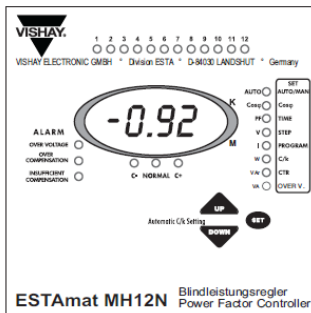

### 5.9 Protection of Capacitor Steps Against Overvoltage

This is a selectable function, either **OFF** (overvoltage protection **Off**) or an overvoltage value between 240-275V can be selected. If "overvoltage" occurs and the overvoltage value is selected (between 240-275V), then all the capacitor steps will be switched off, the **OVERVOLTAGE** LED turns on and the alarm relay will be activated. And if the ESTAmat MH-N is in the manual mode, then it will switch to the automatic mode.

If **OFF** is selected, then overvoltage protection is not available.

Note: For overvoltage values of the ESTAmat MH-N with 380-415 VAC, please refer to technical specifications on chapter 9.

Setting can be made as followed.

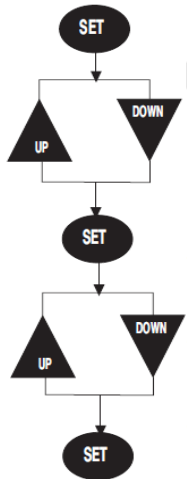

Push the SET button for 3 seconds and enter the SET menu.



Scroll to "OVER V." by means of the UP or DOWN button. **OV** is displayed.

Push the SET button for the overvoltage protection setting. Either **OFF** or the preset overvoltage value is displayed.

Select either **OFF** to cancel the Overvoltage protection function or select a voltage value by the UP or DOWN button.

Push the SET button for 3 seconds and enter the SET menu.

Push the SET button to memorize the selected value. The ESTAmat MH-N returns to normal operating mode.

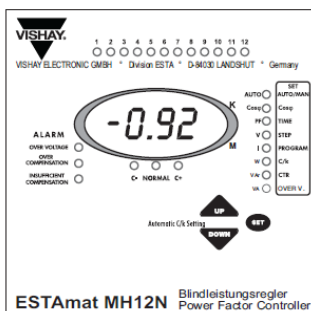



### 5.10 Display of the $\cos\phi$ Value

When the ESTAmat MH-N is in the manual operating mode, the  $\cos\phi$  value and the inductive/capacitive status is always displayed. When the  $\cos\phi$  value is negative, the system is capacitive. And if the  $\cos\phi$  value is positive, the system is inductive. In the automatic operating mode the system's actual  $\cos\phi$  value and the ind./cap. status can be displayed by selecting the  $\cos\phi$  light by means of the UP or DOWN button.

### 5.11 Display of the Power Factor (PF) Value

When the ESTAmat MH-N is in the automatic operating mode (the AUTO/MAN light is continuously ON), the **PF** light can be selected by means of the UP or DOWN button, and the system's power factor value is displayed. This option is not available in the manual operating mode.

#### **Important Definition:**

The  $\cos\phi$  is defined as Power Factor related to the fundamental harmonic only.

The **PF** is defined as the **total** power factor and related to **all** harmonics including the fundamental harmonic. In a system without harmonics, the PF and  $\cos\phi$  will have the same value.

**Attention:** A difference between the  $\cos\phi$  and PF values does not definitely indicate, that harmonic voltages in the network being high enough to result in problems to the system.

### 5.12 Displaying the Voltage and Current RMS Values

When the ESTAmat MH-N is in the automatic operating mode (AUTO/MAN light is ON), and the **V** light is selected, the RMS Voltage (V) value will be displayed.

When the **I** light is selected, the RMS current (I) value will be displayed. The displayed current and voltage values are of the phase where the CT is connected. This option are not available in the manual operating mode.

### 5.13 Display of the Active Power (W) Value

When the ESTAmat MH-N is in the automatic operating mode (AUTO/MAN light is continuously ON), the **W** light can be selected by means of the UP or DOWN button, and the system's active power value is displayed. This option is not available in manual operating mode.

### 5.14 Display of the Reactive Power (VAr) Value

When the ESTAmat MH-N is in the automatic operating mode (AUTO/MAN light is continuously ON), the **VAr** light can be selected by means of the UP or DOWN button, and the system's reactive power value will be displayed. This option is not available in the manual operating mode.

### 5.15 Display of the Apparent Power (VA) Value

When the ESTAmat MH-N is in the automatic operating mode (AUTO/MAN light is continuously ON), the **VA** light can be selected by means of the UP or DOWN button, and the system's apparent power value will be displayed. This option is not available in manual operating mode.

## 6. DESCRIPTION

### 6.1 Errors and Warnings

The alarm relay is activated when the following “errors” occur.

#### 6.1.1 Overvoltage

If the phase-neutral voltage of the L1 phase is equal to or exceeds the preset overvoltage value (between 240-275V), then the ESTAmat MH-N will wait for 3 seconds. At the end of the 3 seconds if there is still overvoltage, then the OVERVOLTAGE LED will turn-on. Depending on the selection of the overvoltage protection function (refer to 5.9), the ESTAmat MH-N switches off all the capacitor steps or continues to improve the power factor.

The overvoltage error disappears, once the set overvoltage value will decrease by 4VAC.

In this case the OVERVOLTAGE LED turns off and the ESTAmat MH-N continues to improve the power factor.

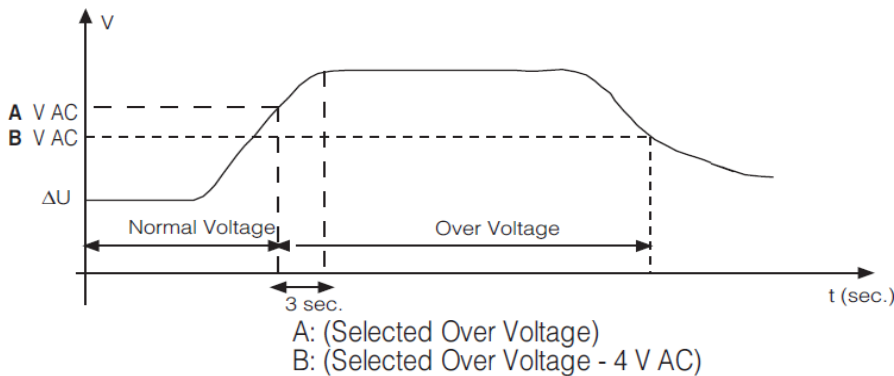

#### 6.1.2 Insufficient Compensation

If the target power factor is not reached although all the capacitor steps have already been connected, the INSUFFICIENT COMPENSATION’s light is ON and the alarm relay is activated.

#### 6.1.3 Overcompensation

If the system is still capacitive although all the capacitor steps are already disconnected, then the OVERCOMPENSATION light is ON and the alarm relay is activated.

### 6.2 Target $\cos\phi$

The target  $\cos\phi$  value can be adjusted in the range of 0.85-1.00 inductive. The ESTAmat MH-N will connect the capacitors in order to bring the system’s power factor to the adjusted value, which is defined as  $1.25 \times Q_{C1}$ . A switching operation will happen within this range.

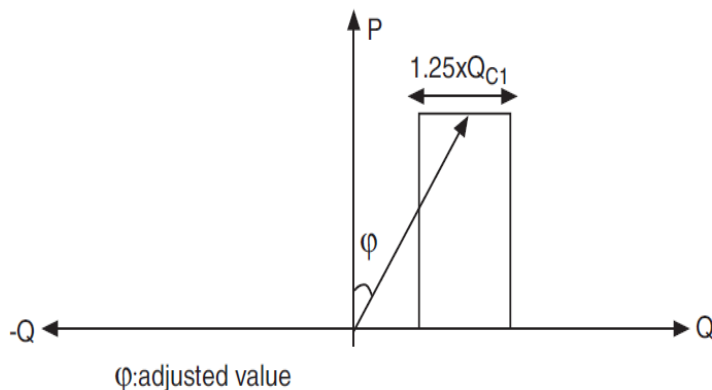





### 6.3 Adjustable Step Switching Time

The step switching on/off delay time can be adjusted between 2 sec.-1800 sec.

**Warning: Shorter time than above range can lead to damage of capacitors and contactors.**

**If the capacitor bank is not discharged by reactors, then the delay time must be selected to be at least 60 seconds. The selected delay time cannot not be shorter than according to the instruction of the manufacturer of the capacitors.**

### 6.4 Switching Program Selection

The ESTAmat MH-N has 5 different program modes to determine the power ratio of the capacitor steps:

PS1 selection ==> 1: 1: 1:.....: 1

PS2 selection ==> 1: 2: 2:.....: 2

PS3 selection ==> 1: 2: 4:.....: 4

PS4 selection ==> 1: 2: 4: 8:....: 8

PS5 selection ==> can be one of the above switching ratios 1-4 and even in higher multiples (but in a different switching mode)

#### 6.4.1 ESTAmat MH-N Capacitor Sequence Examples

The power ratio selection between the capacitor steps is very important. When choosing the ratio between the outputs of the capacitor steps, the first step value will be the smallest and the following steps must be in multiples of the first step.

**Example:** If the first capacitor power is 5 kvar, the capacitor power sequence of the following capacitors is as followed:

PS1 selection ==> 5: 5: 5:.....: 5

PS2 selection ==> 5: 10: 10:.....: 10

PS3 selection ==> 5: 10: 20:.....: 20

**Two different switching modes are available with the ESTAmat MH-N:**

- a) **Circular Mode:** This switching program is clockwise switching in/off all steps of same size to distribute the load and switching operations uniformly on all capacitors and contactors to provide minimum switchings per step for maximum service life of the system. There are 4 different circular switching program available (PS1, PS2, PS3, PS4).
  
- b) **Linear Mode:** The switching program always starts with the first step up to the last one for switching-on and off. The advantage of this switching program is the availability of a large selection of capacitor steps matching to the step ratio rule as explained above. The maximum possible ratio is "x : 2x : 4x : 8x : 16x....".

This switching program is selected in the PS5 option.

### 6.5 Step Number Selection

By selecting the step number, no time is wasted to switch on/off steps without capacitors. As a result, the compensation system can be used more effectively. If the step number is not selected, then the ESTAmat MH-N will switch steps according to the step number, set by the factory, which is the max. available number as defined on the front panel (6 steps for ESTAmat MH6N and 12 steps for ESTAmat MH12N).

### 6.6 C/k Setting

The C/k value is a threshold value for the switching on/off of the capacitor steps. The C/k is the value obtained by dividing the smallest capacitor step size "C" by the current transformer ratio "k". This value is either automatically measured and calculated by the ESTAmat MH-N, or can be entered manually. After simultaneously pressing the UP/DOWN buttons, the C/k value is calculated and memorized within one step switching on/off time interval. The further compensation controls are based on this memorized value. In case of permanent change of the system's load, the measuring process will be restarted. The ESTAmat MH-N will stop the measuring after 10 trials. Then the C/k value cannot be measured due to the instability of the system's load. In this case the compensation control will continue with the value memorized before.



The formula to calculate the C/k value is :

$$C/k = \frac{Q}{k}$$

Q: Power of the first step capacitor (kVar)  
k: Current Transformer Ratio.(CTR)

$$C/k = Q / k$$

Q: Power of the first step capacitor (kvar)

k: Current Transformer Ratio.(CTR)

Based on the fixed network voltage of 400V.

Example :

The output C of the first step capacitor is 5 kvar and the current transformer ratio (k) is 100/5.

Then the C/k value is:  $C/k = 5/(100/5)=0.25$

**C/k value for different C and k parameters (based on 400V):**

CTR (k)	Power of Capacitor Step (kVar) (C)											
	2.5	5	10	12.5	15	20	25	30	40	50	60	100
30/5	0.42	0.83										
50/5	0.25	0.50	1.00									
75/5	0.17	0.33	0.67	0.83	1.00							
100/5	0.13	0.25	0.50	0.63	0.75	1.00						
150/5	0.08	0.17	0.33	0.42	0.50	0.67	0.83	1.00				
200/5	0.06	0.13	0.25	0.31	0.38	0.50	0.63	0.75	1.00			
300/5	0.04	0.08	0.17	0.21	0.25	0.33	0.42	0.50	0.67	0.83	1.00	
400/5	0.03	0.06	0.13	0.16	0.19	0.25	0.31	0.38	0.50	0.63	0.75	
500/5		0.05	0.10	0.13	0.15	0.20	0.25	0.30	0.40	0.50	0.60	1.00
600/5			0.08	0.10	0.13	0.17	0.21	0.25	0.33	0.42	0.50	0.83
800/5			0.06	0.08	0.09	0.13	0.16	0.19	0.25	0.31	0.38	0.63
1000/5			0.05	0.06	0.08	0.10	0.13	0.15	0.20	0.25	0.30	0.50
1250/5				0.05	0.06	0.08	0.10	0.12	0.16	0.20	0.24	0.40
1500/5					0.05	0.07	0.08	0.10	0.13	0.17	0.20	0.33
2000/5						0.05	0.06	0.08	0.10	0.13	0.15	0.25
2500/5							0.05	0.06	0.08	0.10	0.12	0.20
3000/5								0.05	0.07	0.08	0.10	0.17
4000/5									0.05	0.06	0.08	0.13

### 6.7 Determine the Energy Flow Direction

The ESTAmat MH-N provides **four-quadrant** measuring and operation. So it is also possible to determine the direction of the energy flow and to adjust the compensation also in case of energy supply to the grid.

### 6.8 Current Transformer (CT) Selection

There is always a need for a separate CT to be used for the power factor controller. The wires connecting the CT to the power factor controller must be as short as possible and the diameter of the wire not less than 1.5 mm. Since the current information is supplied by the CT, the right selection of the CT is very important. The secondary current of the selected CT must comply with the following current limits for correct measuring:

Minimum = 0.05 mA , Maximum = 5.5 A (Minimum C/k Ratio must be 0.02)



## 7. ERROR DESCRIPTIONS

### 7.1 Wrong $\cos\phi$

Current and voltage phase connection are not correct.

### 7.2 Insufficient Compensation

The output of the capacitor steps may have decreased during the time. The fuses which are connected to the capacitors may have been blown. The total output of the capacitor steps may be insufficient to improve the power factor of the system. In this case the installed capacitor output must be increased.

### 7.3 Overcompensation

This occurs especially at weekends and nights due to capacitive instead of inductive loads. And also by fixed capacitor steps or contactors with stuck contacts due to continuous overcurrent or manually switched in capacitor steps.

### 7.4 Overvoltage

The phase-neutral voltage of L1 has exceeded the preset Overvoltage value.

## 8. EASY INSTALLATION RECOMMENDATION (IMPORTANT NOTICE)

When the load is unstable and varies very quickly, the calculation on the C/k value may take long time or in some cases it cannot be calculated or will be calculated incorrectly, which will cause wrong compensation.

A practical way to prevent this situation is:

1. Turn on the compensation board without connecting the load current. Only the capacitors will be in operation in this situation. ( You can do this by switching off the load current temporarily)
2. Start the C/k calculation process by pressing the UP and DOWN buttons simultaneously. Now, depending on the power of the first step, the C/k value is calculated very accurately by the ESTAmat MH-N. The calculated C/k value will automatically memorized. Now the load can be switched on. This C/k value will be kept in the memory until it is recalculated or changed manually.



## 9. TECHNICAL SPECIFICATIONS

Rated Voltage (Un)	230V Ph/N (standard version)
Operating Voltage Range( $\Delta U$ )	(0.9 - 1.1) x Un
Operating Current Range( $\Delta I$ )	50 mA - 5.5A
Rated Frequency	50 Hz / 60 Hz
Measuring Class	1% $\pm 1$ digit (V, I, $\cos\phi$ ), 2% $\pm 1$ digit (W, VAr, VA)
Power Consumption	Measuring Current circuit: < 2 VA Measuring/Supply Voltage circuit: 3 VA - 10 VA
Output Contact	3 A, 250 VAC (NO Contact)
No-Volt Feature	In case of power failure longer than 200 msec all capacitor steps are disconnected automatically
Setting Range	Manual C/k Setting: 0.02 - 1.0 Cos $\phi$ Setting: 0.85 (ind.) - 1.00 CT Ratio: 5 – 10000
Time Delay	Between 2 sec. - 1800 sec.
Overvoltage	240 - 275 V
Factory Set Values	Cos $\phi$ =1.00 (ind.), Step Time=60 sec. Program=PS5, C/k=0.05 CT Ratio =5
Number of Steps	ESTAmat MH12N (max 12); MH6N (max 6)
Ambient Temperature	-5°C / + 55°C
Display	4 Digit, Seven-segment Display
Equipment Protection Class (Appliance Classes)	Double Insulation-Class II
Overvoltage Category	CAT III
Wire (For Terminal Block)	2.5 mm <sup>2</sup> cross section
Protection Class Terminals	IP 00
Protection Class Front Side	IP 40
Connections	Multipoint connectors with screws for wire connection
Switchboard cut-out	139x139 mm
Weight	0.8 kg



**10. DIMENSIONS**

