

N5 Digital-display PID temperature controller

FC5 Series

Manual Instructions

Pls read the following safety considerations before use

■ Safety Considerations

※ Please observe all safety considerations for safe and proper product operations to avoid hazards.

※ Safety considerations are categorized as follows.

⚠ Warning Failure to follow these instructions may result in serious injury or death.

⚠ Caution Failure to follow these instructions may result in personal injury or product damage.

⚠ Warning

- Fail-safe device must be installed when using the unit with machinery that may cause serious injury or substantial economic loss.** (e.g. nuclear power control, medical equipment, ships, vehicles, railways, aircraft, combustion apparatus, safety equipment, crime/disaster prevention devices, etc.) Failure to follow this instruction may result in personal injury, fire, or economic loss.
- The unit must be installed on a device panel before use.** Failure to follow this instruction may result in electric shock.
- Do not connect, repair, or inspect the unit while connected to a power source.** Failure to follow this instruction may result in electric shock.
- Check the terminal numbers before connecting the power source.** Failure to follow this instruction may result in fire.
- Do not disassemble or modify the unit. Please contact us if necessary.** Failure to follow this instruction may result in electric shock or fire.

⚠ Caution

- Do not use the unit outdoors.** Failure to follow this instruction may result in shorten the life cycle of the unit, or electric shock.
- When connecting the power input and relay output cables, use AWG20(0.50mm²) cables and make sure to tighten the terminal screw bolt above 0.74N.m to 0.90N.m.** Failure to follow this instruction may result in fire due to contact failure.
- Use the unit within the rated specifications.** Failure to follow this instruction may result in shorten the life cycle of the unit or fire.
- Do not use loads beyond the rated switching capacity of the relay contact.** Failure to follow this instruction may result in insulation failure, contact melt, contact failure, relay broken or fire.
- Do not use water or oil-based detergent when cleaning the unit. Use dry cloth to clean the unit.** Failure to follow this instruction may result in electric shock or fire.
- Do not use the unit where flammable or explosive gas, humidity, direct sunlight, radiant heat, vibration, or impact may be present.** Failure to follow this instruction may result in fire or explosion.
- Keep dust and wire residue from flowing into the unit.** Failure to follow this instruction may result in fire or product damage.
- Check the polarity of the measurement input contact before wiring the temperature sensor.** Failure to follow this instruction may result in fire or explosion.
- For installing the unit with reinforced insulation, use the power supply unit which basic level is ensured.**

■ Model composition

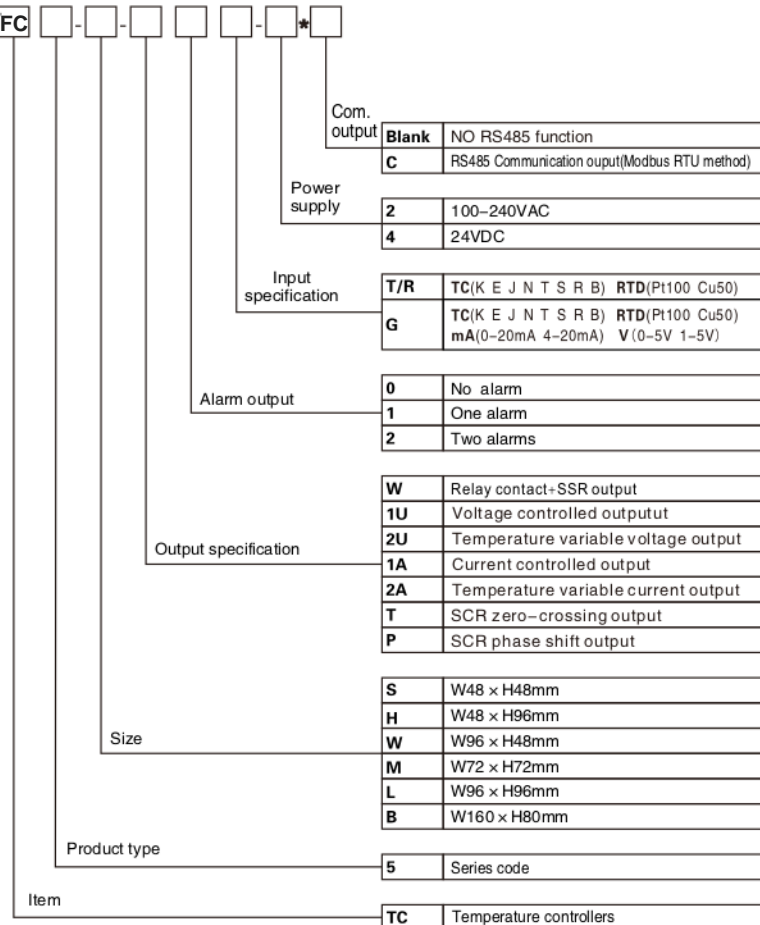

■ Specifications

Power supply	①100-240VAC ②24VDC	
Allowable voltage range	90-110% of rated voltage	
Power consumption	Max.8VA	
Input specification	TC	K E J N T S R B
	RTD	Pt100 Cu50
	Linear current	0-20mA 4-20mA
	Linear voltage	0-5V 1-5V
Display accuracy	± 0.5%	
Output specification	Relay contact output 250VAC 5A 1NO1NC	
	SSR 12VDC ± 2V below 20mA	
	Voltage output(control output / variable output)	
	Current output(control output / variable output)	
	SCR output (zero-crossing output / phase shift output)	
Option output	Alarm output	Relay 250VAC 5A Max.two sets of alarm outputs
	Com. output	RS485 Communication output(Modbus RTU method)
Control method	ON/OFF position control, PID control	
Sampling period	100ms	
Relay life cycle	Mechanical above 2.5 million times, Electrical above 100000 times	
Dielectric strength	2000VAC 50/60Hz for 1 min. (between all terminals and case)	
Vibration	0.75mm amplitude at frequency 5 to 55Hz(for1 min.) in eachX,Y,Z direction for 2 hours	
Insulation resistance	Min.100MΩ (500VDC) MEGA	
Noise resistance	Square shaped noise by noise simulator(pulse width 1 μs) ± 2kV R-phase,S-phase	
Memory retention	Approx. 10years(non-volatile semiconductor memory type)	
Environment	Ambient temp.	-5-40°C storage:-10-50°C
	Ambient humi.	35%-85%RH storage:35-85%RH

■ Dimensions

Unit:mm

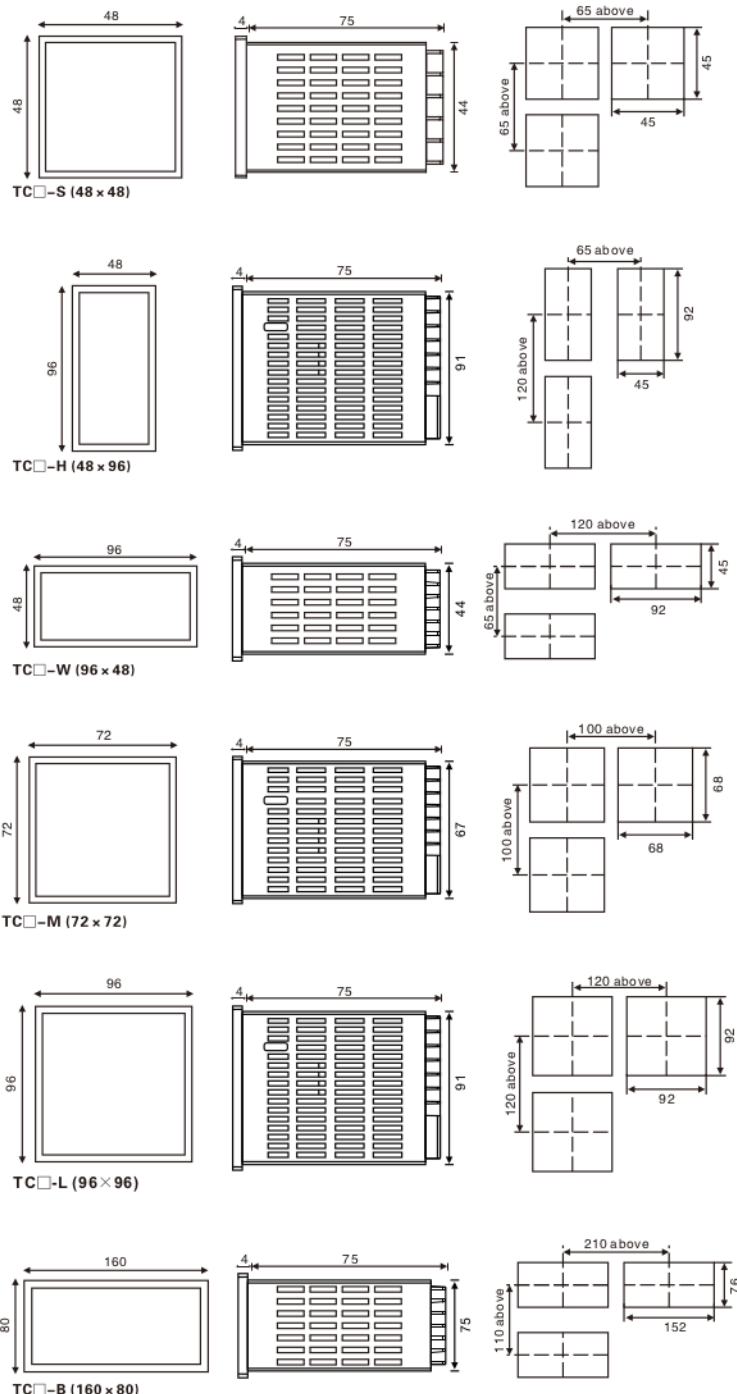

Parts description

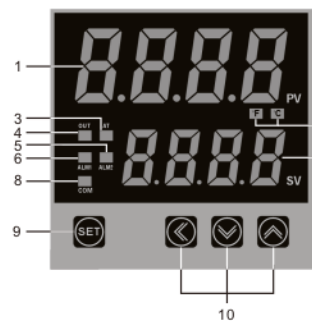

- 1. Present value (PV) display**
1) RUN mode: Present value (PV) display
2) Parameter setting mode: Parameter display
- 2. Set value (SV) display**
1) RUN mode: Set value (SV) display
2) Parameter setting mode: Parameter setting value display
- 3. Auto tuning(AT) indicator**
Flash when the auto-tuning function working
- 4. Control output(OUT) indicator**
When control output is ON, the light turns ON
- 5. Alarm output2 indicator (ALM2)**
When alarm 2 output is ON, the light turns ON
- 6. Alarm output1 indicator (ALM1)**
When alarm 1 output is ON, the light turns ON
- 7. Temperature unit (°C/°F) indicator**
When °C indicator lights up, the unit is Celsius and °F indicator lights up, it is in Fahrenheit
- 8. Communication output (COM) indicator**
Flash when communication working
- 9. SET key**
Used when entering into parameter setting group, returning to RUN mode, turn the parameters down, and saving the set values
- 10. [Left], [Down], [Up] key**
Used when entering into set value change mode and digit up/down, press and hold the [Left] + [Down] keys for 3s to use the shortcut function

Parameter Setting

1. All parameter

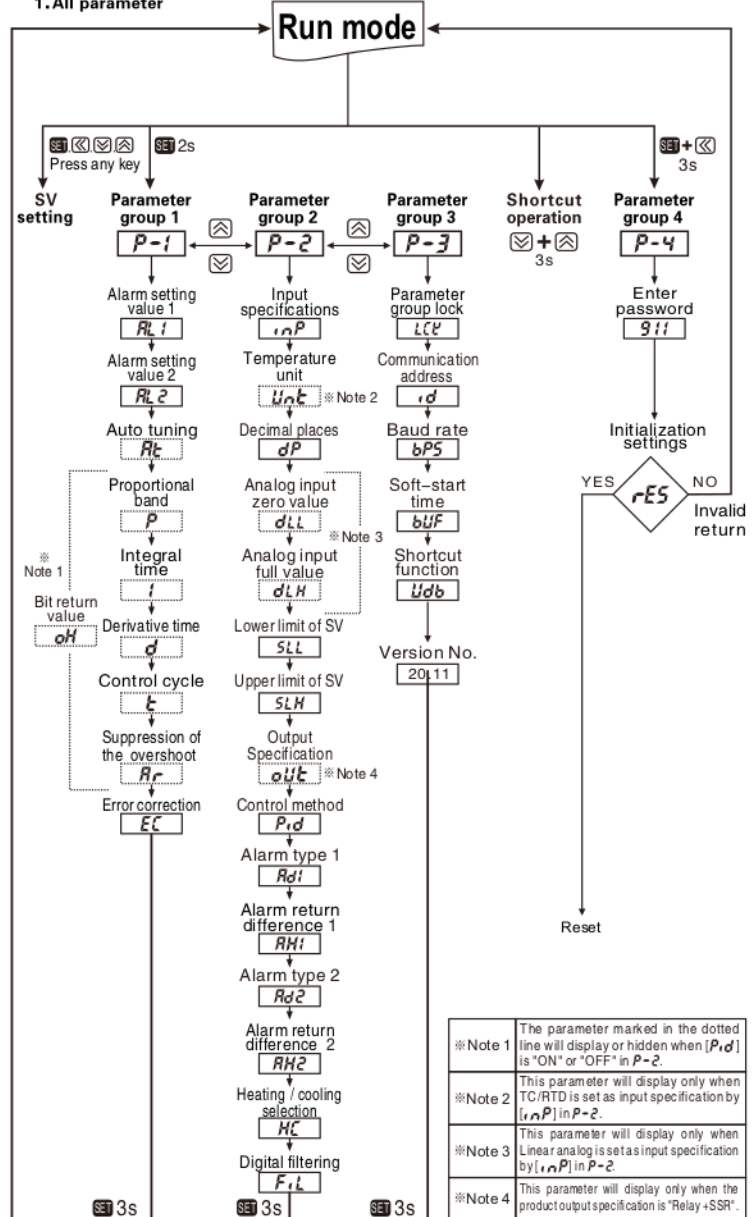

- ※ Note 1 The parameter marked in the dotted line will display or hidden when [P,d] is "ON" or "OFF" in P-2.
- ※ Note 2 This parameter will display only when TC/RTD is set as input specification by [r,nP] in P-2.
- ※ Note 3 This parameter will display only when Linear analog is set as input specification by [r,nP] in P-2.
- ※ Note 4 This parameter will display only when the product output specification is "Relay+SSR".

- ※ In the parameter setting mode, if no key is pressed within 30s, it will automatically return to the RUN mode and the changed parameters will not be saved.
- ※ In each parameter group, press [SET] once to save the set value and go to the next parameter.
- ※ In each parameter group, press [SET] for 3s to save the set value and return to the RUN mode. (In SV setting, press [SET] only once)
- ※ The parameters marked by [] may not be displayed depending on the model or other parameter settings.
- ※ When the [r,nP], [U,nE], and [dP] parameters are changed, [SLL], [SLH], [RH1], [RH2] in "Parameter group 2", [RL1], [RL2], [EC] in "Parameter group 1" and the "SV" setting value parameter all will be initialized.
- ※ Set parameter as "parameter group 2" → "parameter group 1" → "SV setting" order considering parameter relation of each setting group.
- ※ After restoring the factory settings: 1. All parameters will be restored to the factory default (except for [r,d], [bPS], [bUF] in "Parameter group 3" and [oUt] in "Parameter group 2"). 2. Input specification defaults to "Required value of order" 3. The SV setting value is restored to "100".

2. Parameter group 2 [P-2]

Setting item	Parameter	Range	Factory default	Description
Input specification	r,nP	See table of input specifications and using range		
Temperature unit	U,nE	°C or °F	°C	Set temperature units (°C or °F)
Decimal places	dP	0-3	0	Decimal places
Analog input zero value	dLL	-999-9999	40	For example, when the input is 4-20mA, show display value of 4mA
Analog input full value	dLH	-999-9999	200	For example, when the input is 4-20mA, show display value of 20mA
Lower limit of SV	SLL	The minimum lower limit of the corresponding sensor type		Limit the lower limit of SV
Upper limit of SV	SLH	The maximum upper limit of the corresponding sensor type		Limit the upper limit of SV
Output Specification	oUt	RLY or SSR	RLY	Output specification selection, RLY for relay output, SSR for SSR output
Control Method	P,d	ON or OFF	ON	Control method selection, ON is PID control, OFF is ON / OFF position control.
Alarm Type1	Rd1	00-16	01	12 kinds of alarm types selection, see the alarm type for details.
Alarm Return Difference 1	RH1	0-100	1	The difference required to return to the non-alarm state in the first set of alarm states
Alarm Type2	Rd2	00-16	00	12 kinds of alarm types selection, see the alarm type for details.
Alarm Return Difference 2	RH2	0-100	1	The difference required to return to the non-alarm state in the second set of alarm states
Heating/cooling Selection	H,C	HET or COL	HET	HET is heating mode, COL is cooling mode.
Digital Filter	F,iL	0-59	5	Unit is second, input sampling value filtering period

※ Input specifications and usage range table

Input Specification	Display	Decimal places	Range of use (°C)	Range of use (°F)
Therm-ocouple	K	0	-30 ~ 1300	-22 ~ 2372
		1	-30.0 ~ 999.9	-22.0 ~ 999.9
	E	0	-30 ~ 700	-22 ~ 1292
		1	-30.0 ~ 700.0	-22.0 ~ 999.9
	J	0	-30 ~ 900	-22 ~ 1652
		1	-30.0 ~ 900.0	-22.0 ~ 999.9
	N	0	-30 ~ 1000	-22 ~ 1832
		1	-30.0 ~ 999.0	-22.0 ~ 999.9
	T	0	-30 ~ 400	-22 ~ 752
		1	-30.0 ~ 400.0	-22.0 ~ 752.0
	S	0	0 ~ 1760	32 ~ 3200
		1	0 ~ 999.0	32.0 ~ 999.9
R	0	0 ~ 1750	32 ~ 3182	
	1	0 ~ 999.0	32.0 ~ 999.9	
B	0	200 ~ 1800	392 ~ 3272	
	1	200.0 ~ 999.0	392.0 ~ 999.9	
Thermal resistance	Pt100	0	-200 ~ 650	-328 ~ 1202
		1	-99.0 ~ 650.0	-99.9 ~ 999.9
	Cu50	0	-50 ~ 150	-58 ~ 302
Linear analog	4-20mA	RY	0	-999 ~ 9999
	0-20mA	RD	1	-99.9 ~ 999.9
	1-5V	UI	2	-9.99 ~ 99.99
0-5V	UD	3	-.999 ~ 9.999	

3. Parameter group 1 [P-1]

Setting item	Parameter	Range	Factory default	Description
Alarm setting value1	RL1	The whole range	10	Set alarm1 data.
Alarm setting value2	RL2	The whole range	10	Set alarm2 data.
Auto-tuning switch	Rt	ON or OFF	OFF	ON open auto-tuning OFF close auto-tuning.
Proportional band	P	0.1 ~ 999.9	30.0	Proportional band of PID control, the unit is °C, recommended by auto-tuning.
Integral time	i	0 ~ 9999	240	Integral time of PID control, the unit is second, recommended by auto-tuning.
Derivative time	d	0 ~ 9999	60	Derivative time of PID control, the unit is second, recommended by auto-tuning.
Control cycle	t	1 ~ 100	2 or 20	PID output control cycle, the recommended relay output is 20 seconds and the SSR output is 2 seconds.
Suppression of the overshoot	Rr	1 ~ 100	60	Used to suppress PID control overshoot, auxiliary control, recommended by auto-tuning.
Bit return control	oH	1 ~ 999	2	Set the interval between on and off for control (this parameter is displayed only in bit control)
Error correction	EC	-99-999	0	Error correction of display temperature.

4. Parameter group 3 [P-3]

Setting item	Parameter	Range	Factory default	Description
Parameter group lock	LcP	0 1 2 3 4	0	0 Unlock 1 Lock [P-3] 2 Lock [P-3], [P-2] 3 Lock [P-3], [P-2] 4 Lock [P-3], [P-2], [P-1], SV setting
Communication address	r,d	001 ~ 099	1	User set address
Baud rate	bPS	24 48 96 192 384	96	Multiply by 100 when reading the set value
Soft-start time	bUF	0 ~ 999	0	Unit is second, only for Linear analog output or phase shift output
Shortcut function	Udb	OFF AT AL OUT	OUT	See shortcut operation for more details
Version No.	Display the current version No., e.g. 20.11			For recording software changes

※When the current parameter group is locked, it can be viewed but not modified.

5. SV setting

You can set the temperature to control with \leftarrow , \rightarrow , \uparrow , \downarrow key.
Ex) In case of changing set temperature from 240°C to 250°C

1) Press any key among \leftarrow , \rightarrow , \uparrow , \downarrow key in RUN mode, the right digit as SV display flashes and it enters to SV setting group.

2) Press \leftarrow key to move the desired digit.

3) Press \downarrow or \uparrow key to move the desired number.

4) Press \rightarrow key to save the value and it controls with this set value.

6. Shortcut operation

- Press and hold the \leftarrow + \rightarrow work for 3s to work the shortcut function.
- The specific function depends on the shortcut function type [*Udb*] in "Parameter group 3".
- Factory default : RELAY/SSR switching.
- This function is not affected by the parameter group lock [*LLP*].

Shortcut Key Parameters	Display	Description
OFF	/	No shortcut function.
AT	AL ₁ ON, AL ₁ OFF	For auto-tuning work/stop, same function as Auto-tuning [<i>At</i>] in "Parameter group 1", ON for work, OFF for stop.
AL	AL ₁ ON, AL ₁ OFF	The user can force the alarm to be released when it is alarm. ON is not released, OFF is released. When the alarm range is exceeded, this function is reset.
OUT	OUT ₁ RLY, OUT ₁ SSR	For changing output specifications, same function as output specification [<i>Out</i>] in "Parameter group 2". RLY for relay output, SSR for SSR output

7. Restore factory settings

- Press and hold \leftarrow + \rightarrow at the same time for 3s and then enter into "Parameter group 4" and enter the password 911, which will enter into the parameter reset [*rES*].
- Select "no" and previous settings are maintained. Select "YES" and all parameters resume to default setting.
- The [*rd*], [*bPS*], [*bUF*] in "Parameter group 3" and [*out*] in "Parameter group 2" are not restored.

Functions

1. Auto tuning [*At*]

- PID auto-tuning measures the control subject's thermal characteristics and thermal response rate, and then determines the necessary PID time constant. And through this function, automatic setting of parameters can be realized to achieve high-speed and stable control.
- During auto tuning, the heating system should be in working condition, the measured value PV is lower than the set value SV.
- Control method [*P,d*] when parameters are in state of "on", auto tuning switch will be displayed.
- Set the auto-tuning switch [*At*] in state of "on", AT indicator light starts flashing to indicate that it has entered the auto-tuning state.
- During auto tuning process, all parameter groups and SV settings will be locked. If manual interruption of auto-tuning, the auto-tuning switch [*At*] should be set to "off".
- During auto-tuning process, it will be automatically interrupted if there are failures code "HHHH" or "LLLL".
- When finish auto tuning, AT indicator light stop flashing, the resulting parameters *P*, *i*, *d*, *R* are automatically saved, then return to new control state as new parameters *P*, *i*, *d*, *R* and other parameters continue to run.
- Any interruption of auto tuning, the parameters *P*, *i*, *d*, *R* and other parameters will not be modified.

2. Control method [*P,d*]

Control method [*P,d*] when parameters are in state of "on", currently belongs to PID control mode. if it is in the "off" state, it is in the ON/OFF position control state.

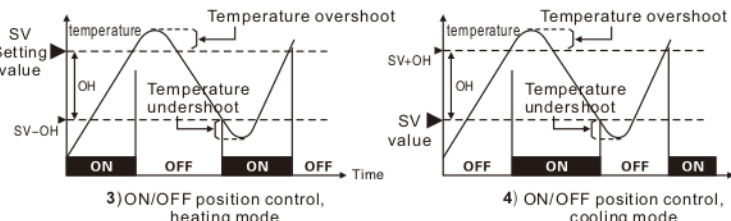
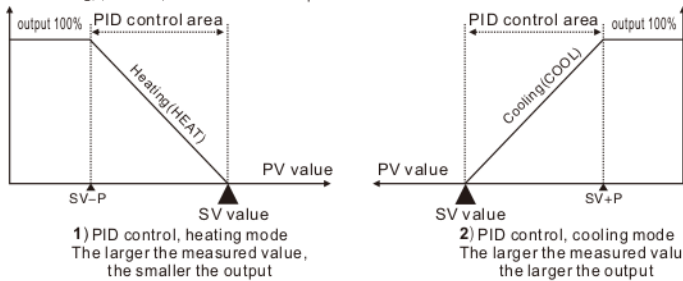

3. Suppression of the overshoot [*Rr*]

When the PID control is used, suppression of the overshoot adjustment is made. The larger the setting value is, the faster the heating is and the overshoot is easy. The smaller the setting value is, the slower the heating is, and the overshoot is not easy. factory default is 60, and it is recommended to set the value by PID auto tuning.

4. Position control return difference [*oH*]

- Set the interval between ON and OFF for controlling output in ON/OFF position control.
- Control method [*P,d*] when parameters are in state of "off" bit difference [*oH*] will be displayed.
- If the hysteresis is too small, control output instability may occur due to external interference, etc.

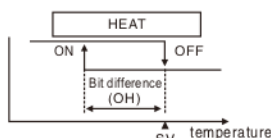

5. Soft-start time [*bUF*]

- When a heating system is first put into operation, the present value (PV) is well below the set value (SV) while the OUT output reaches 100%. In some industries, this can seriously threaten the life of the heating system when the system often goes from a low temperature state to full power instantaneously.
- The Soft-start time range limits the output to 25%, which acts as a buffer and extends the life of the heating system.
- The time unit is s.
- Acts only on analog outputs or phase shifted outputs.

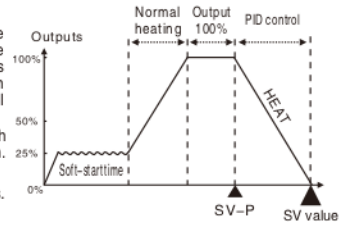

6. Error correction [*EC*]

- Controller itself does not have errors but there may be error by external input temperature sensor. This function is for correcting this error. if actual temperature is 80°C but controller displays 78°C, set input correction value [*EC*] as "002" and controller displays 80°C.
- Setting range -99~999°C
- As the result of error correction, if current temperature value (PV) is over the limit range, it displays "HHHH" or "LLLL".

7. Digital filtering [*FIL*]

- The present value (PV) may change repeatedly due to unstable input signal or external interference, which may prevent accurate control. In this case, the digital filtering function can be used to stabilize the present value (PV) and achieve accurate control.
- If the digital filtering is set to 1 second, the input sample values will be filtered in 1 second cycles.
- When using this function, it is normal that the present value (PV) may deviate from the actual input value.

8. Alarm type1 [*Rd1*]

Set value	Alarm	Positive alarm value (AL1)	Negative alarm value (-AL1)	Deviation alarm/ absolute value alarm
0	No alarm function	No output		
1	Upper limit Deviation	ON	ON	Deviation alarm
2	Lower limit Deviation	ON	ON	Deviation alarm
3	Interval alarm	ON	ON	Always off
4	Off-range alarm	ON	ON	Always on
5	Absolute upper limit	ON	ON	Absolute value alarm
6	Absolute lower limit	ON	ON	Absolute value alarm
10	No alarm function	No output		
11	Upper limit deviation of standby	ON	ON	Deviation alarm
12	Lower limit deviation of standby	ON	ON	Deviation alarm
13	Alarm within standby	ON	ON	Always off
14	Alarm outside standby	ON	ON	Always on
15	Absolute upper limit of standby	ON	ON	Absolute value alarm
16	Absolute lower limit of standby	ON	ON	Absolute value alarm

9. Alarm type2 [*Rd2*]

- Idem, the default is "0".
- Deviation alarm**
Use when you want to set up a temperature to produce a linkage. The alarm action point will change with the change of setting temperature.

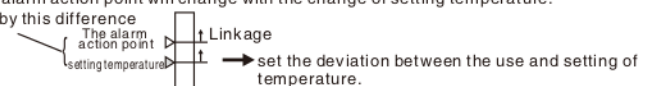

Absolute value alarm

- No need to use linkage with setting temperature
- Operating temperature (absolute value)
- Set alarm action point
- alarm action point Fixed set with the temperature (absolute value) at which the alarm is issued.

Standby function

- The standby function means that start from the present value is out of the alarm range, and to the next alarm range before, even if the alarm ON condition is reached, the alarm will not be ON.
- Ex) alarm types: lower limit deviation of standby

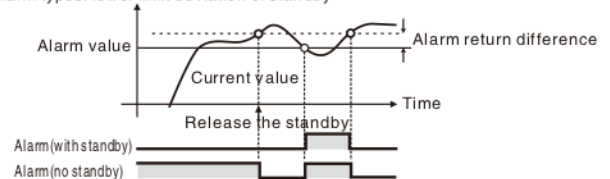

10. Alarm return difference [*RH1*]

- It is used to return to the difference of non-alarm state under the alarm state.
- For example, the alarm action is 120°C in total, and set the alarm return difference is 20°C. It is the alarm state when the temperature reaches above 120°C, and it is the non-alarm state when the temperature falls below 100°C.
- Set range: 0 ~ 100°C.
- The factory default: 1°C

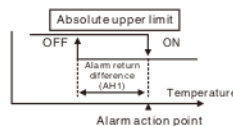

11. Alarm return difference [*RH2*]

- Idem, the default is "1"

Error

Display	Description	Troubleshooting
HHHH	Input broken or out of input range	Pls check if the input signal is wrong
LLLL	Input broken or out of input range	Pls check if the input signal is wrong

