

**Features:**

- Isolated mounting base 3000V~
- Pressure contact technology with Increased power cycling capability
- Space and weight saving

**Typical Applications**

- Various rectifiers
- DC supply for PWM inverter

V <sub>RRM</sub>	Type & Outline
800V	MDx250-08-413F3D
1000V	MDx250-10-413F3D
1250V	MDx250-12-413F3D
1400V	MDx250-14-413F3D
1600V	MDx250-16-413F3D
1800V	MDx250-18-413F3D
1800V	MD250-18-413F3DG

MDx stands for any type of **MDC, MDA, MDK**

SYMBOL	CHARACTERISTIC	TEST CONDITIONS	T <sub>j</sub> (°C)	VALUE			UNIT
				Min	Type	Max	
I <sub>F(AV)</sub>	Mean forward current	180° half sine wave 50Hz Single side cooled, T <sub>c</sub> =100°C	150			250	A
I <sub>F(RMS)</sub>	RMS forward current					393	A
I <sub>RRM</sub>	Repetitive peak current	at V <sub>RRM</sub>	150			20	mA
I <sub>FSM</sub>	Surge forward current	V <sub>R</sub> =60%V <sub>RRM</sub> , t=10ms half sine,	150			8.5	kA
I <sup>2</sup> t	I <sup>2</sup> t for fusing coordination					361	10 <sup>3</sup> A <sup>2</sup> s
V <sub>Fo</sub>	Threshold voltage		150			0.75	V
r <sub>F</sub>	Forward slope resistance					0.76	mΩ
V <sub>FM</sub>	Peak forward voltage	I <sub>FM</sub> =750A	25			1.35	V
R <sub>th(j-c)</sub>	Thermal resistance Junction to case	At 180° sine. Single side cooled				0.14	°C/W
R <sub>th(c-h)</sub>	Thermal resistance case to heatsink	At 180° sine. Single side cooled				0.04	°C/W
V <sub>iso</sub>	Isolation voltage	50Hz, R.M.S, t=1min, I <sub>iso</sub> :1mA(MAX)		3000			V
F <sub>m</sub>	Terminal connection torque(M8)			10		12	N·m
	Mounting torque(M6)			4.5		6	N·m
T <sub>vj</sub>	Junction temperature			-40		150	°C
T <sub>stg</sub>	Stored temperature			-40		125	°C
W <sub>t</sub>	Weight				770		g
Outline	413F3D						

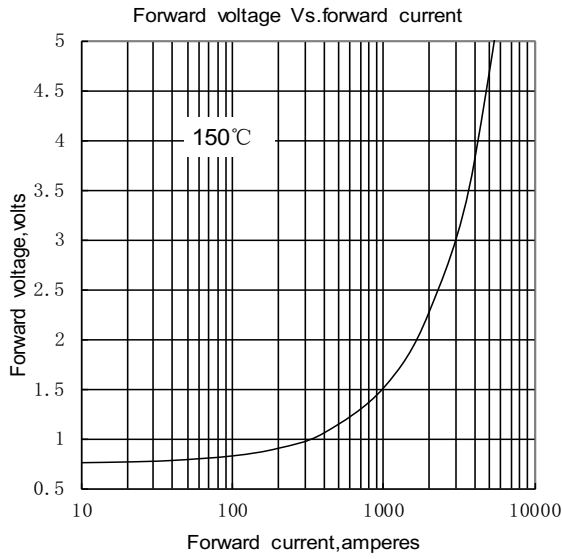

Fig.1

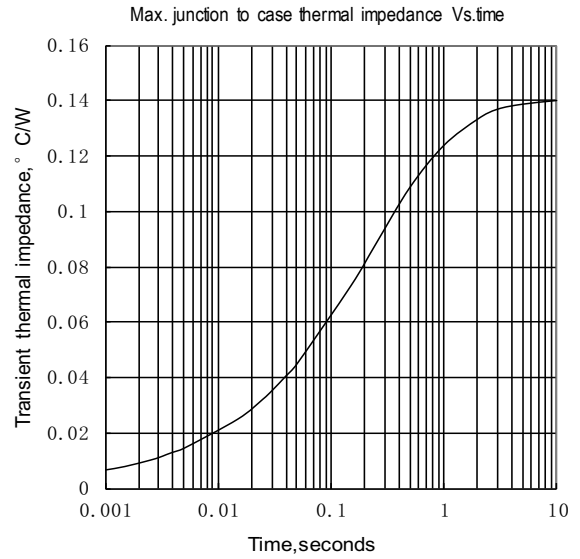

Fig.2

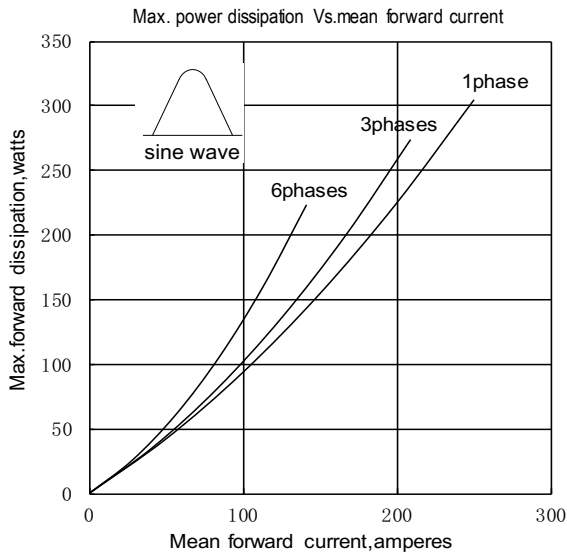

Fig.3

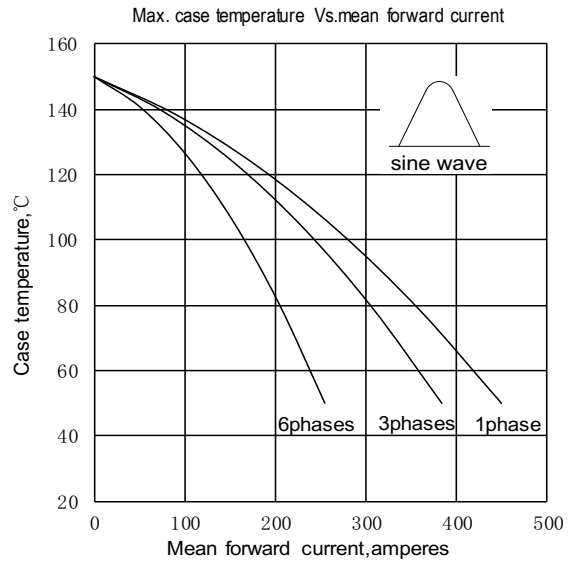

Fig.4

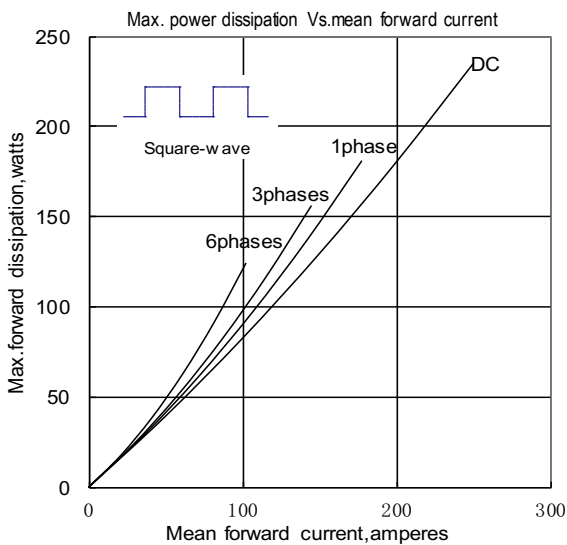

Fig.5

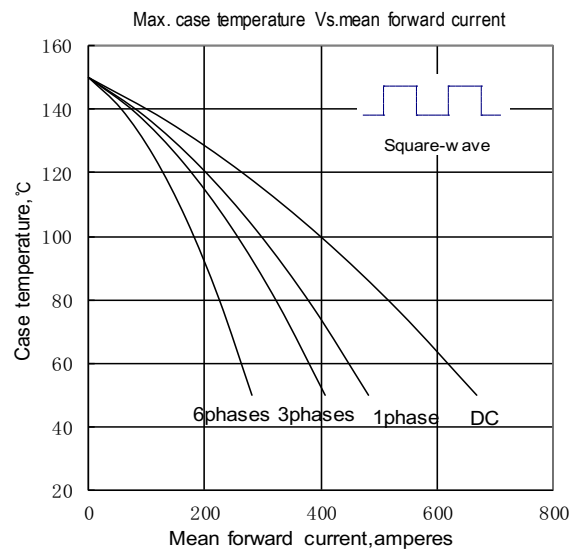

Fig.6

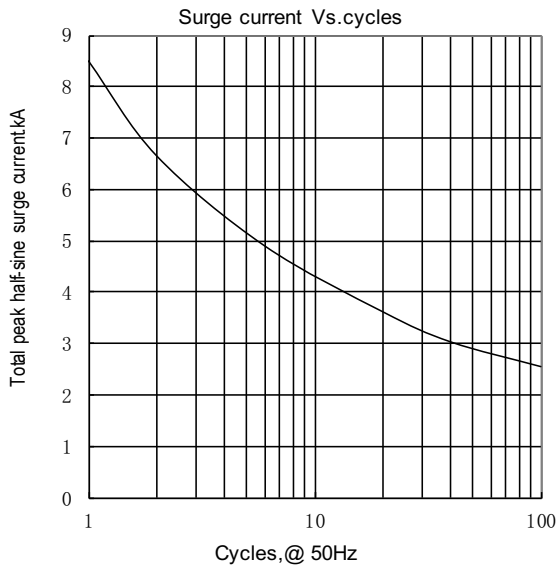

Fig.7

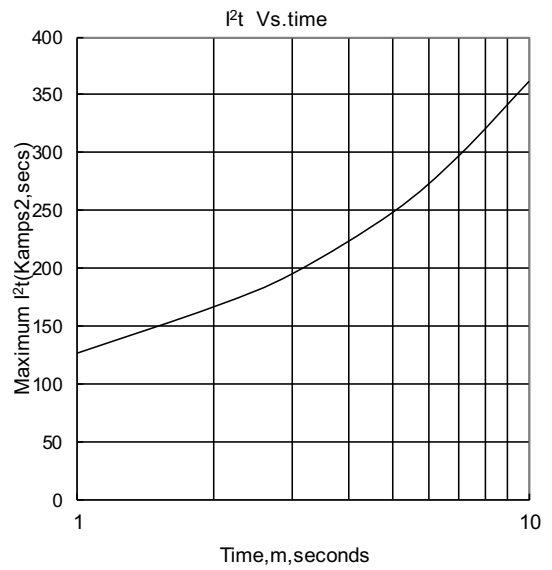
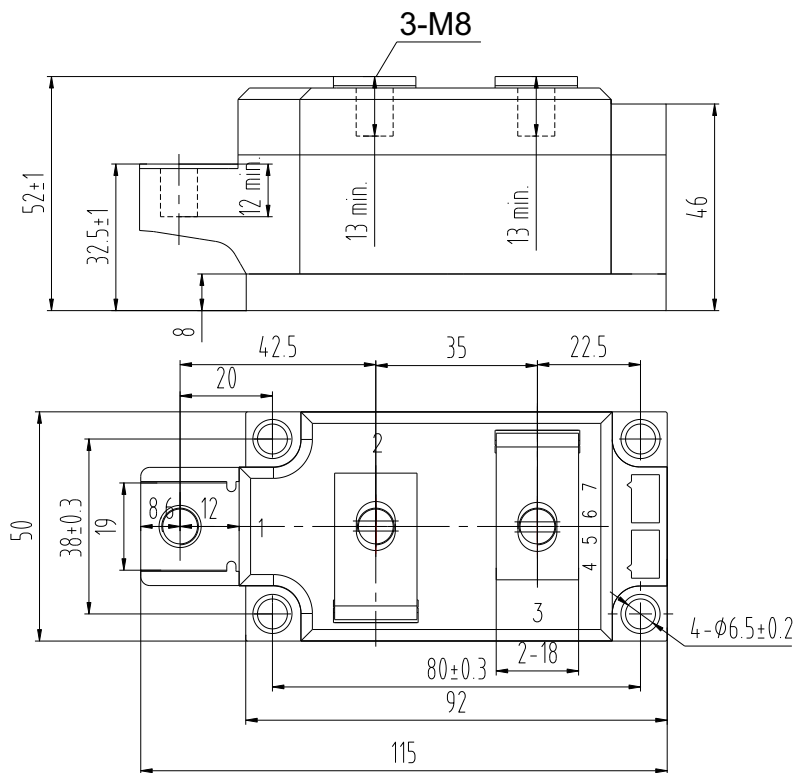

Fig.8

Outline:



Unmarked dimensional tolerance: ±0.5mm

