



# Data Sheet

## RISH CON-M

RISH CON M-40/ M-04/ M-22



Measure



Control



Record



Analyze

### Application :

The **RISH CON - M** transducer is used to measure and convert parameter of Three-phase 3W/4W AC power network with balanced or unbalanced system.

It ensures that the measurement and conversion of measured values into standard analog current signals. Relay outputs signal the overflow of the selected quantities, and the pulse output can be used for the consumption monitoring of the 3-phase active energy.

### Salient Features :

- True RMS measurement.
- Fully **onsite programmable** input PT & CT ratio.
- Detection and signaling of incorrect phase sequence.
- THD Measurement.
- Programmable parameters through the **RS-485** interface or USB when using the free **eCon** configuration software
- **Onsite selectable analog output range (0...20mA/4...20mA/-20...+20mA).**
- Fast and easy installation on DIN RAIL or onto a wall or in a panel using optional screw hole bracket.
- Connection Terminal : Conventional Screw type.

### Product Features:

#### Measuring Input:

AC Voltage/Current input signal, sine wave or distorted wave form.

#### Analog Output :

Analog output which can be set in between -20mA...20mA onsite. Admissible overflow on analog output: 20% of lower and upper value.

#### Programmable PT,CT Ratio:

The Transducer can be programmed onsite using through RS 485 or USB port..

#### LED Indication:

LED indication for power on, RS485 transmission, reception and alarm switching .

#### RS485 Communication:

RS485 communication is available. For reading measured parameter & onsite configuration of input/output.

#### USB Communication:

RS485 communication is available. For reading measured parameter & onsite configuration of input/output.



Fig. 1 RISH CON - M

#### Energy Measurement:

Tetraquadrantic energy measurement (Ep+, Ep-, EqL, Eqc).

#### Mean Active Power :

Measurement of 15, 30 or 60 minutes' mean active power (synchronization by an internal clock or a walking window) with the archiving function of 1000 last samples.

#### Galvanic Isolation:

Transducer output signal are galvanically isolated from the input signal.

#### Pulse constant of OC type output:

5000-20000imp./KWh, independently on setting of ratios Ku, Ki

#### Alarm Indications:

The alarm indication can be set for measured input parameter.



Measure



Control



Record



Analyze

## Technical Specifications:

## Measuring Ranges and Admissible Basic Errors

Table 1

Measured quantity	Measuring range	L1	L2	L3	$\Sigma$	Basic error
Current 1/5A L1...L3	0.02...6 A~	●	●	●		±0.2%
Voltage L-N	57.7V~ 230.0V~ 2.9...69.24V~ 11.5...276 V~	●	●	●		±0.2%
Voltage L-L	100.0V~ 400.0V~ 5.0... 120V~ 20... 480V~	●	●	●		±0.5%
Frequency	47.0...63.0 Hz	●	●	●		±0.2%
Active power	-1.65 kW...1.4 W...1.65 kW	●	●	●	●	±0.5%
Reactive power	-1.65 kv ar...1.4 var...1.65 kvar	●	●	●	●	±0.5%
Apparent power	1.4 VA...1.65 kVA	●	●	●	●	±0.5%
PF factor	-1...0...1	●	●	●	●	±0.5%
Tangens $\phi$	-1.2...0...1.2	●	●	●	●	±1%
Cosinus $\phi$	-1...1	●	●	●	●	±1%
Angle between U and I	-180 °... 180 °	●	●	●		±0.5%
Input active energy	0...99 999 999.9 kWh				●	±0.5%
Developed active energy	0...99 999 999.9 kvarh				●	±0.5%
Reactive inductive energy	0...99 999 999.9 kWh				●	±0.5%
Reactive capacitive energy	0...99 999 999.9 kvarh				●	±0.5%
THD in the range 10...120% U,I; 48...52 Hz; 58.62 Hz	0...100%	●	●	●	●	±5%

**Caution!** For correct current measurement, the presence of voltage with the value higher than 0.05 Un is required at least on one phase

## Power Consumption:

- in supply circuit  $\leq 10$  VA
- in voltage circuit  $\leq 0.05$  VA
- in current circuit  $\leq 0.1$  VA



Measure



Control



Record



Analyze

<b>Analog Outputs:</b>	0, 2 or 4 programmable outputs: - 20...0...+20 mA, $R_{load}$ : 0..750 $\Omega$ Accuracy: 0.2%, Response Time: 3sec. ( Note- For admissible overflow of 20% on analog output R load = 0..600 $\Omega$ )
<b>Relay Outputs:</b>	0, 2 or 4 relays, voltageless NO contacts load capacity 250 V~/ 0.5 A~
<b>Serial Interface:</b>	RS-485: address 1...247; mode: 8N2, 8E1, 8O1, 8N1; baud rate: 4.8, 9.6, 19.2, 38.4 kbit/s, USB: 1.1 / 2.0, address 1; mode 8N2; baud rate 9.6 kbit/s,
<b>Transmission Protocol:</b>	Modbus RTU Response time: 500 ms
<b>Energy Pulse Output:</b>	output of OC type, passive acc. to EN 62053-31
<b>Pulse Constant of OC Type Output:</b>	5000 -20000 imp./kWh, independently on settings ratios $K_u$ , $K_i$
<b>Ratio of the Voltage Transformer <math>K_u</math>:</b>	0.1..... 4000.0
<b>Ratio of the Current Transformer <math>K_i</math>:</b>	1...10000
<b>Protection Degree:</b>	
- for the housing	IP 40
- from terminals	IP 20
<b>Weight:</b>	0.45 kg
<b>Dimensions:</b>	122.5 x 66.0 x 106.5mm
<b>Mounting position:</b>	Rail mounting/wall mounting
<b>Reference and Rated Operating Conditions:</b>	
Supply voltage	85...253 V a.c. 40...400 Hz; 90...320 V d.c. or 20...40V a.c. 40...400 Hz; 20...60 V d.c.



Measure



Control



Record



Analyze

Input Signal :	
Voltage	0...0.05...1.2 Rated Value(Un)
Current	0...0.005...1.2 Rated value (In)
Frequency	47...63 Hz
Power factors (Pf)	-1...0...1(0 Lag...1...Lead 0) (0...0.1...1.2In and 0...0.1...1.2Un) sinusoidal(THD≤8%)
Tangens( φ)	-1.2...0...1.2 (0...0.1...1.2In and 0...0.1...1.2Un) sinusoidal (THD ≤ 8%)
Analog outputs	-24...-20...0...+20...24 mA
Ambient temperature	-10...23...+55°C
Storage temperature	-30...+70 °C
Relative humidity	25...95% ( inadmissible condensation)
Admissible peak factor:	
- current	2
- voltage	2
External magnetic field	0..40...400 A/m
Short duration overload 5 sec.:	
- voltage inputs	2Un (max.1000 V)
- current inputs	10 In
Work position	any
Preheating time	5 min.

### Additional errors:

In percentage of the basic error:	
From frequency of input signals	< 50%
From ambient temperature changes	< 50%/10°C
For THD > 8%	< 100%

### Standards Fulfilled by the Meter

#### **Electromagnetic Compatibility:**

Noise immunity	acc. to EN 61000-6-2
Noise emission	acc. to EN 61000-6-4



Measure



Control



Record



Analyze

### Safety Requirements:

Isolation between circuits	1min. ( EN 61010-1) 3110V DC, All terminals versus outer surface 3110V DC, Input versus all other circuit 3110V DC, Auxiliary supply versus outer surface and all other circuit. (Note - No isolation between the analog outputs )
Installation category	III
Pollution level	2
Maximal phase-to-earth voltage	
- for supply and measurement circuit	300 V
- for other circuits	50 V
Altitude above sea level	< 2000 m,

### LED Indication

Table2

LED	State	Indication
ON	Green continuous	Aux Supply healthy condition and calibration ok
Rx	Pulsing	Data reception through RS485
Tx	Pulsing	Data transmission through Rs485
AL1....AL4	Continuous ON	Alarm ON

### Terminal Details

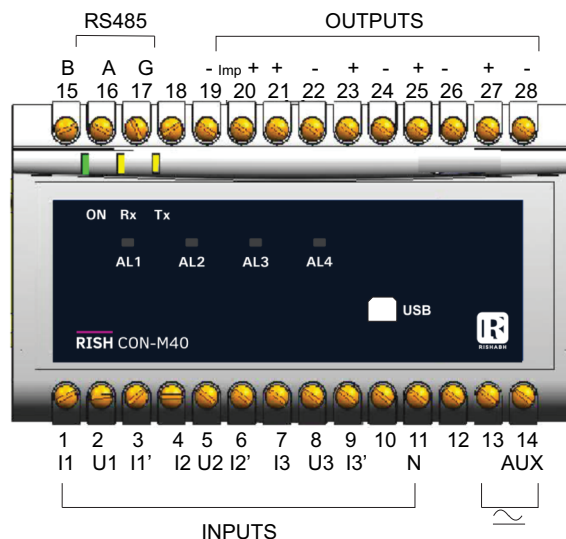

Fig 2.Terminal Details



Measure



Control



Record



Analyze

### External connections :

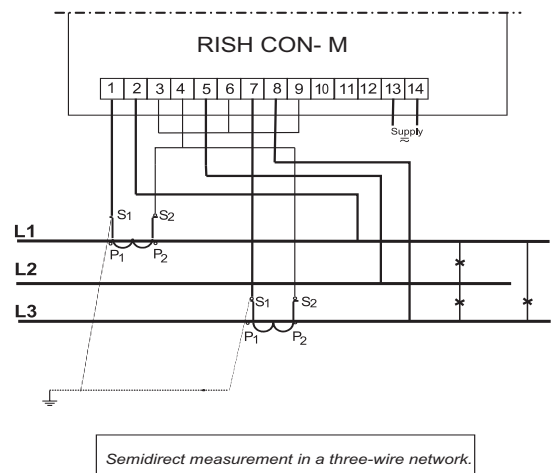
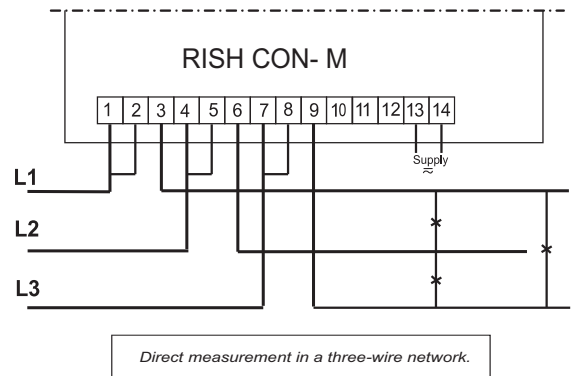
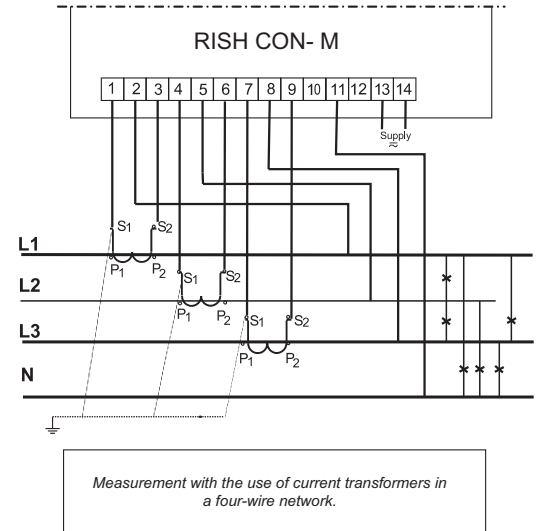
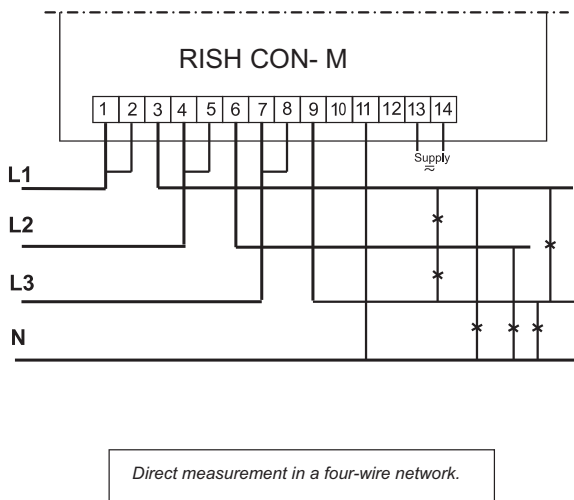
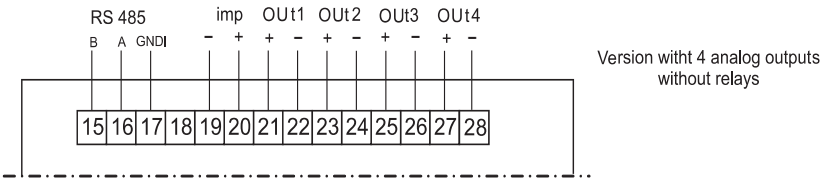
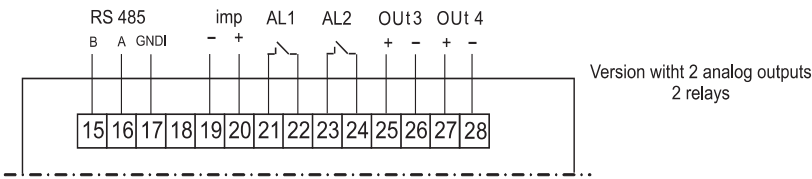
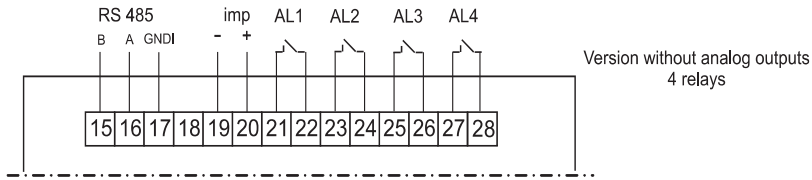

Measure



Control



Record



Analyze

### Electrical Networks :

Indirect measurement with the use of 3 current transformers and 2 or 3 voltage transformers in a four-wire network.

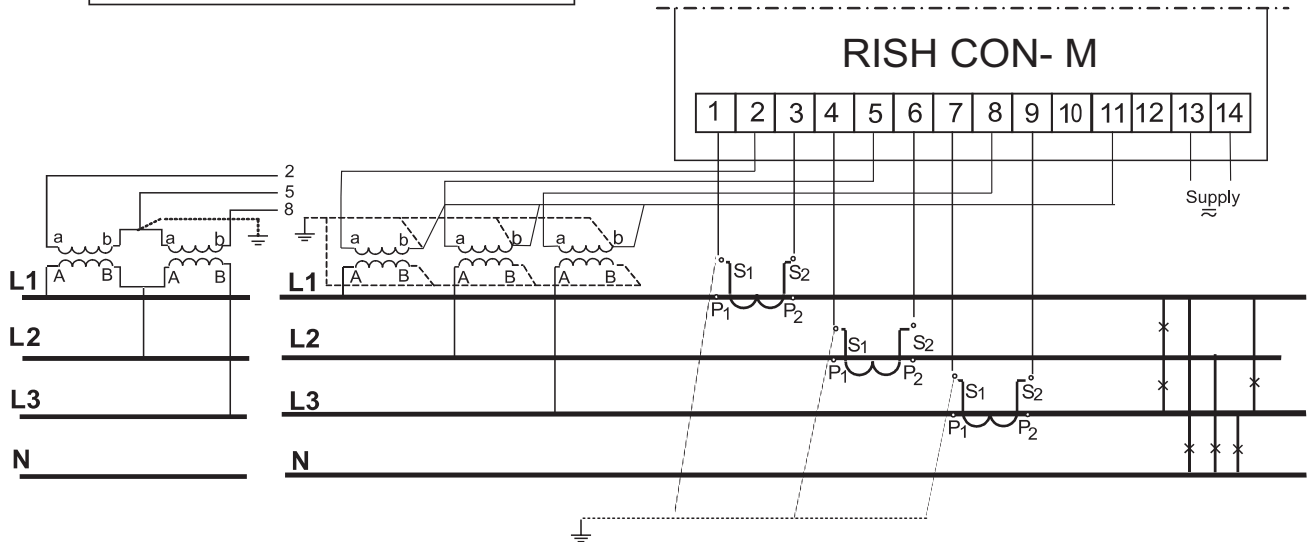

Indirect measurement with the use of 2 current transformers and 2 or 3 voltage transformers in a three-wire network.

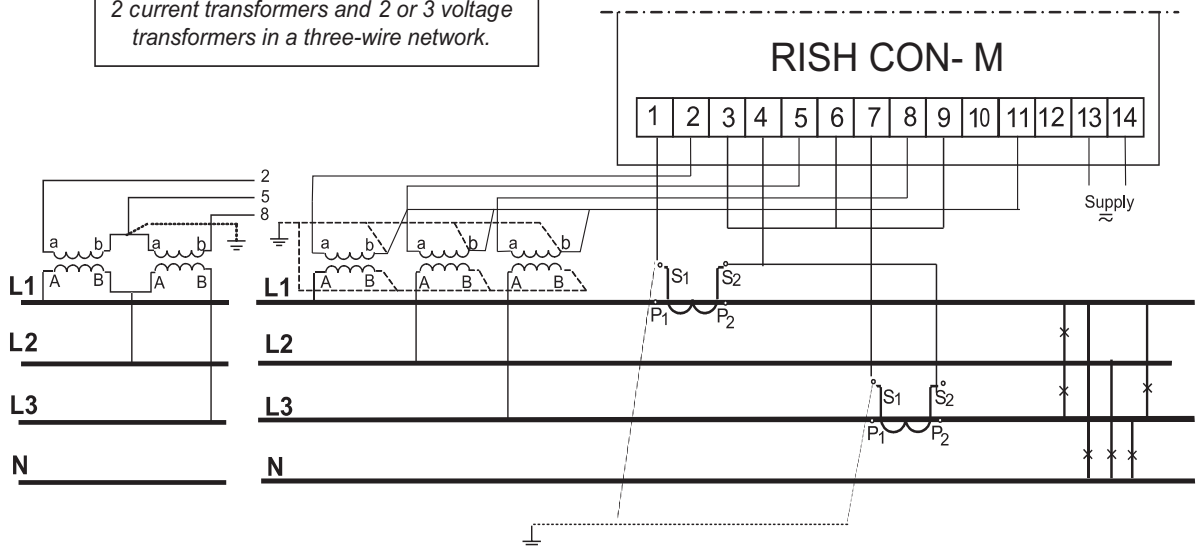

Fig 3. Electrical connections



Measure



Control



Record



Analyze



### Programming

#### Programming of transducer

The eCon software is destined for the configuration of transducer. one must connect the transducer to a pc computer through the rs485 converter ,if the communication will be performed using Rs485 interface or directly through the USB.

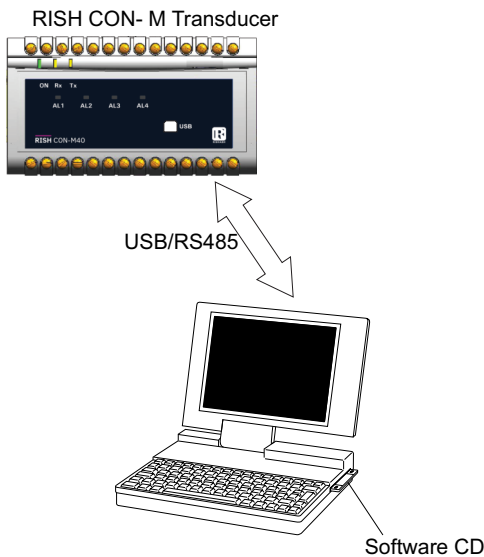

Fig 4. Configuration of the transducer

### Dimensions

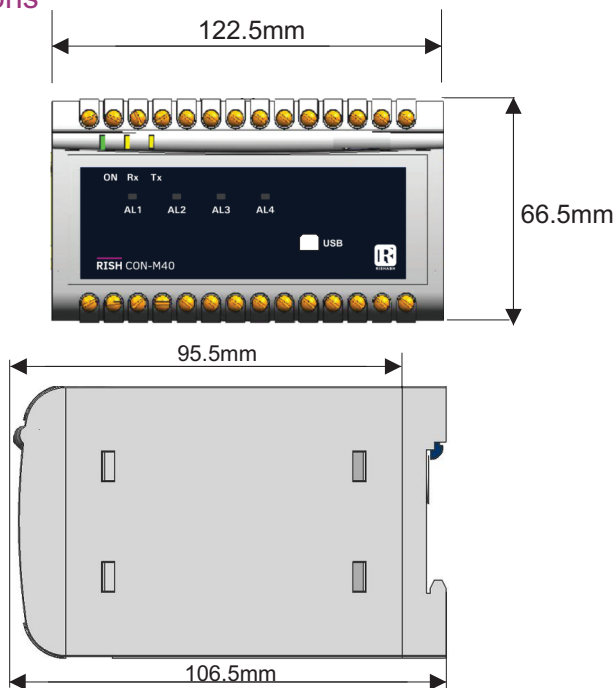

Fig 5. ( All dimensions are in mm.)

### Ordering Information

RISH CON-M	X	X	X	X	X
<b>Current input In:</b>					
1 A (X/1)	1				
5 A (X/5)	2				
<b>Voltage input (phase/Phase-to-phase) Un:</b>					
3 phase 57.7/100 V		1			
3 phase 230/400 V		2			
<b>Supply voltage:</b>					
85..253 V a.c., 90..320 V d.c.			1		
20-40 V AC/20-60 V DC			2		
<b>Output type:</b>					
without analog outputs, 4 relays				1	
2 analog outputs, 2 relays				2	
4 analog outputs, without relays				3	
<b>Load Resistance (RL):</b>					
250 Ohm					1
750 Ohm					2

### Model Types

Model Code	Model Type
RISH CON M - 40	4 Analog Output type
Model Code M - 04	4 Relay Output type
Model Code M - 22	2 Analog 2 Relay Output type



Measure



Control



Record



Analyze



RISHABH

All specifications are subject to change without notice



Measure



Control



Record



Analyze

## RISHABH INSTRUMENTS LIMITED

Domestic (India): +91 253 2202028/99 | [marketing@rishabh.co.in](mailto:marketing@rishabh.co.in)

International: +91 253 2202004/06/08/99 | [global@rishabh.co.in](mailto:global@rishabh.co.in)

[www.rishabh.co.in](http://www.rishabh.co.in)