

Features :

- Isolated mounting base 3000V~
- Pressure contact technology with Increased power cycling capability
- Space and weight saving

Typical Applications

- Soft start

| Part No. MTx2000-18-436F3-R | |
|-------------------------------------|--------------------|
| V _{RRM} , V _{DRM} | Type & Outline |
| 1000V | MTx2000-10-436F3-R |
| 1200V | MTx2000-12-436F3-R |
| 1400V | MTx2000-14-436F3-R |
| 1600V | MTx2000-16-436F3-R |
| 1800V | MTx2000-18-436F3-R |
| 1800V | MT2000-18-436F3G-R |

MTx stands for any type of MTC, MTA, MTK

| SYMBOL | CHARACTERISTIC | TEST CONDITIONS | T _J (C) | VALUE | | | UNIT |
|--------------------------------------|--|--|--------------------|-------|------|-------|----------------------------------|
| | | | | Min | Type | Max | |
| I _{T(AV)} | Mean on-state current | 180 half sine wave 50Hz Single side cooled, T _c =55C | 125 | | | 2000 | A |
| I _{DRM} I _{RRM} | Repetitive peak current | at V _{DRM} at V _{RRM} | 125 | | | 130 | mA |
| I _{TSM} | Surge on-state current | V _R =0, t=10ms half sine | 125 | | | 54.7 | kA |
| I _{TSM} | Surge on-state current | V _R =V _{RRM} , t=10ms half sine | 125 | | | 36.5 | kA |
| I ² t | I ² t for fusing coordination | | 125 | | | 6660 | 10 ³ A ² s |
| V _{TO} | Threshold voltage | | 125 | | | 0.80 | V |
| r _T | On-state slope resistance | | | | | 0.14 | mΩ |
| V _{TM} | Peak on-state voltage | I _{TM} =3000A | 25 | | | 1.60 | V |
| dv/dt | Critical rate of rise of off-state voltage | V _{DM} =67%V _{DRM} | 125 | | | 1000 | V/μs |
| di/dt | Critical rate of rise of on-state current | Gate source 1.5A t _r ≤0.5μs Repetitive | 125 | | | 200 | A/μs |
| I _{GT} | Gate trigger current | V _A =12V, I _A =1A | 25 | 40 | | 200 | mA |
| V _{GT} | Gate trigger voltage | | | 1.0 | | 3.0 | V |
| I _H | Holding current | | | 20 | | 200 | mA |
| V _{GD} | Non-trigger gate voltage | V _{DM} =67%V _{DRM} | 125 | | | 0.20 | V |
| R _{th(j-c)} | Thermal resistance Junction to case | Single side cooled per chip | | | | 0.025 | C/W |
| R _{th(c-h)} | Thermal resistance case to heatsink | Single side cooled per chip | | | | 0.018 | C/W |
| V _{iso} | Isolation voltage | 50Hz, R.M.S, t=1min, I _{iso} : 1mA(MAX) | | 3000 | | | V |
| F _m | Terminal connection torque(M14) | | | 16 | | 18 | N·m |
| | Mounting torque(M8) | | | 10 | | 12 | N·m |
| T _{vj} | Junction temperature | | | -40 | | 125 | C |
| T _{stg} | Stored temperature | | | -40 | | 125 | C |
| W _t | Weight | | | | 6800 | | g |
| Outline | 436F3 | | | | | | |

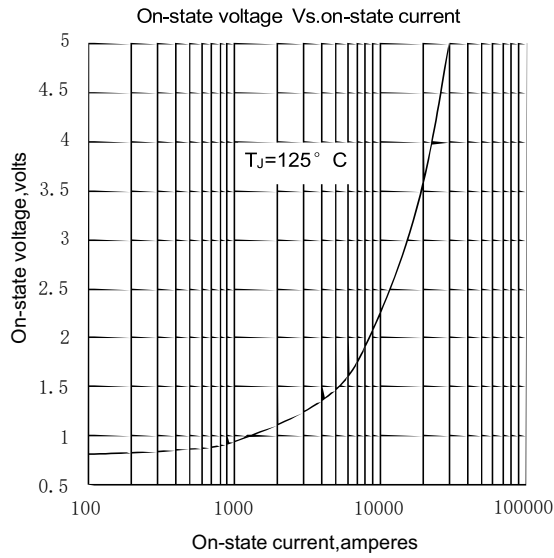

Fig.1

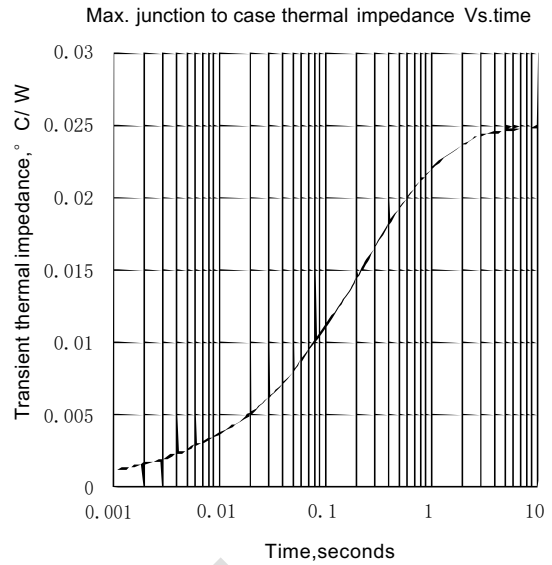

Fig.2

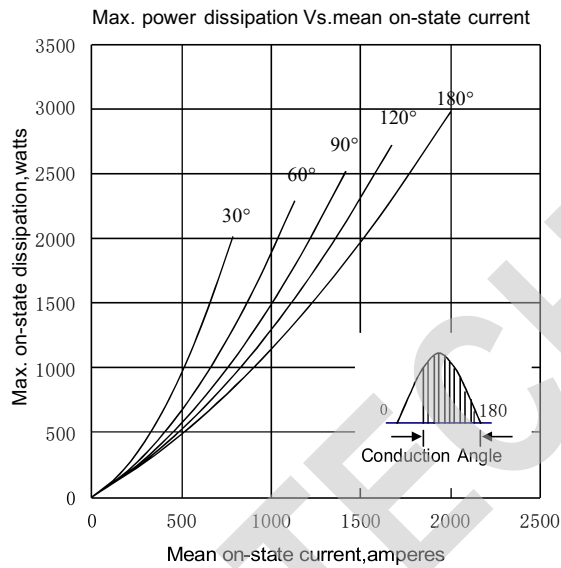

Fig.3

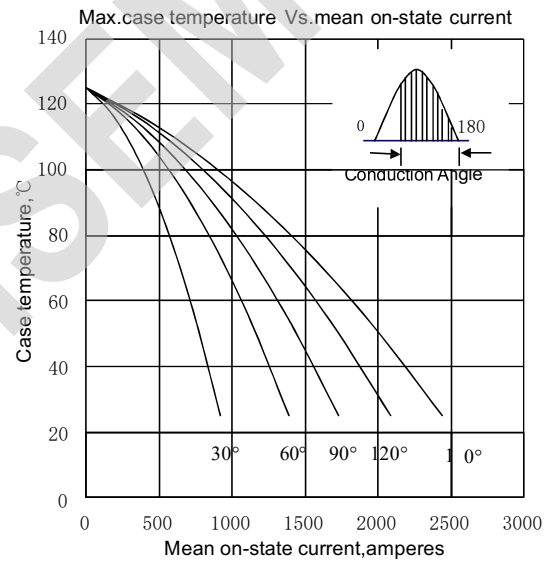

Fig.4

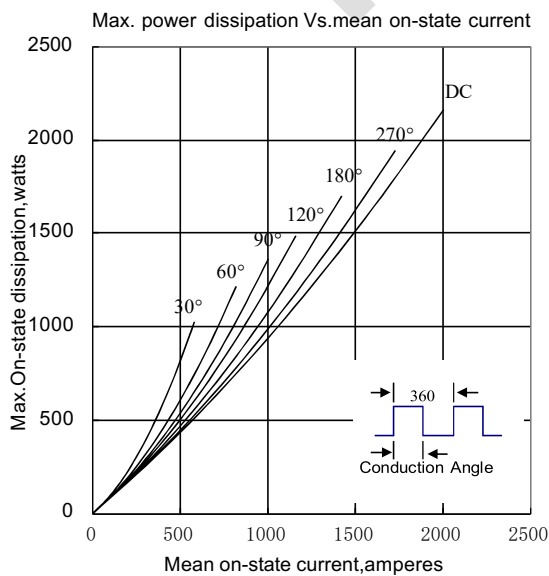

Fig.5

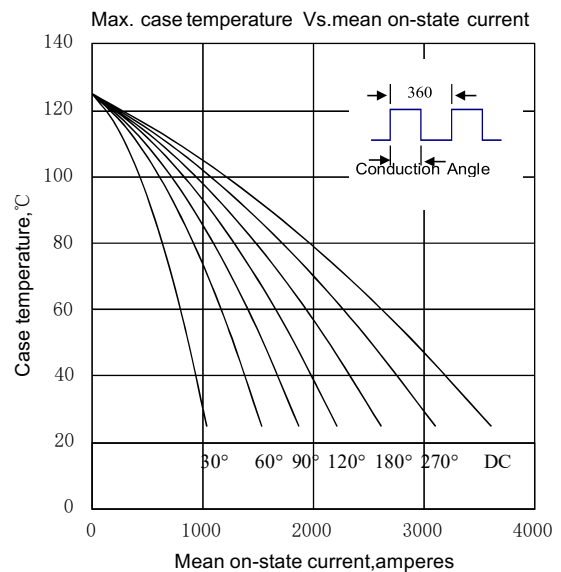

Fig.6

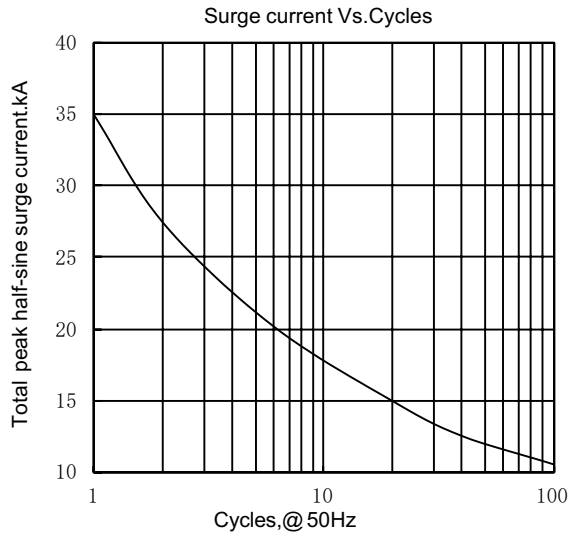

Fig.7

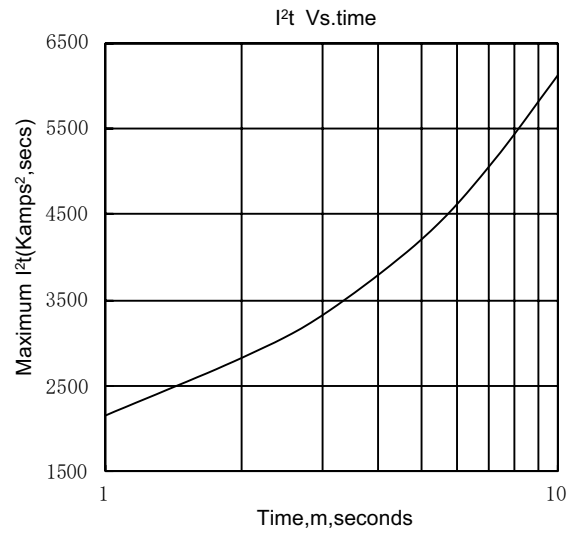

Fig.8

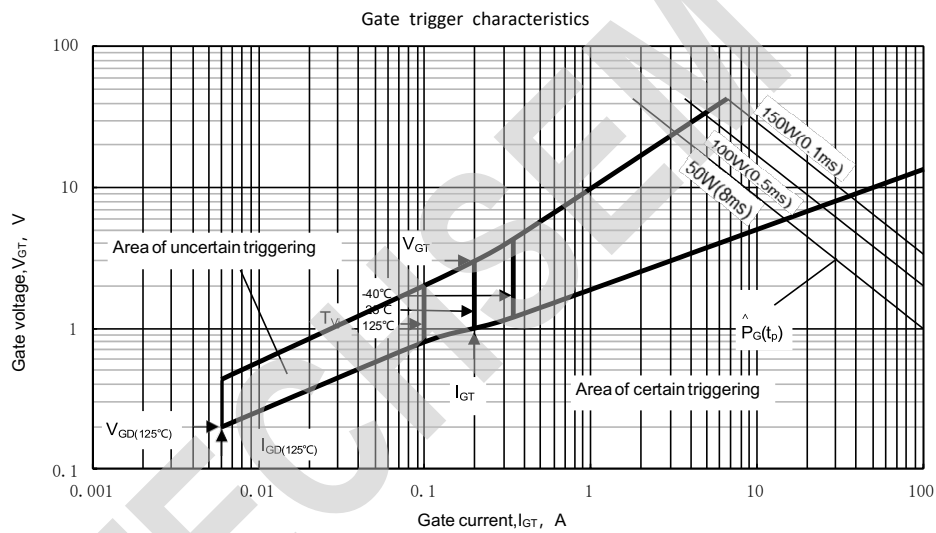
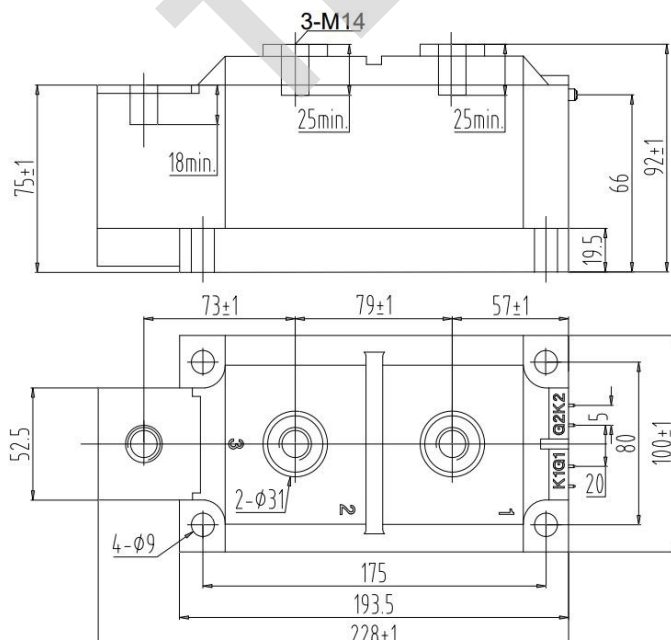
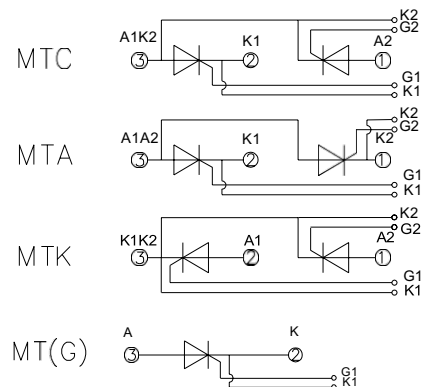

Fig.9

Outline:



Unmarked dimensional tolerance: ±0.5mm



TECHSEM reserves the right to change specifications without notice.