

RXC15 SERIES

High Voltage Contactors

225A+ CONTINUOUS DUTY

1000Vdc SYSTEM VOLTAGE



FEATURES

SPST Normally Open High Voltage Contactors

- Hermetic seal with gas fill
- Optional auxiliary contacts – for main position feedback
- High temperature performance
- Meets RoHS 2011/65/EU
- Designed and Assembled in US



PERFORMANCE

TABLE 1. SPECIFICATIONS

CHARACTERISTIC	MEASURE
Contact Arrangement	Form X, SPST NO
Max Switching Voltage ²	1000 VDC
Dielectric Withstand Voltage (Between Open Contacts)	2200 VRMS (60 sec)
(Between Contacts and Coil)	2200 VRMS (60 sec)
Continuous Current (67mm ² conductor) ⁵	300A
Overload Current 30 Seconds	800A
3 Minutes	500A
Make and Break	See table
Max Short Circuit Current -1 second	1500 A
Min Insulation Resistance	100 MΩ @ 1,000V
Contact Resistance (Max) measured at 200A	0.3 mΩ
(Typical) measured at 200A	0.15-.25 mΩ
Operate Time (Max, incl bounce)	25ms
Release Time (Max)	10ms
Shock - Functional, 1/2 Sine, 11ms	20G
Shock – Destructive, 1/2 Sine, 11ms	50G
Operating Temperature	-40°C to 100°C (175°C max terminal temperature)
Ingress Protection	Exceeds IP69, (Hermetically sealed)
Mechanical life	300,000
AUXILIARY CONTACTS	MEASURE
Contact Arrangement	SPST, Normally Open
Continuous Current	2A
Minimum Current	5mA @ 8V
COIL (20°C)	MEASURE
Nominal Voltage	12 VDC 24 VDC 48 VDC
Max Voltage	16 VDC 32 VDC 85 VDC
Pick-up Voltage (Max) ³	7.5 VDC 15 VDC 32 VDC
Drop-out Voltage (Min)	0.6 VDC 1.2 VDC 2.5 VDC
Pull-in current (max 300ms)	4.3A 1.6A 0.8A
Holding Current	0.24A 0.09A 0.05A
Coil Power (pull-in)	46W 38W 38W
Coil Power (Holding)	2.9W 2.2W 2.2W
Coil Back EMF (V) ⁴ via internal TVS	150V 150V 0V

Momentary Current Carry
(2AWG & 2/0 busbar)

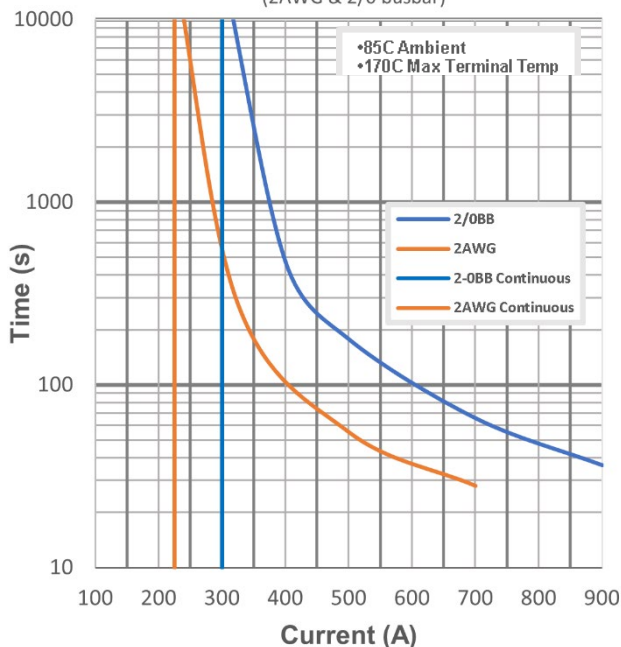

TABLE 2. RESISTIVE LOAD SWITCHING (MAKE / BREAK DATA)

POLARITY SENSITIVE VERSION	CURRENT	CYCLES (1 cycle = 1 make + 1 break)
450V	150A	10,000
750V	150A	1,500
320V	-150A	20
320V	1200A	1
750V	50A	10,000
450V	100A	30,000
1000V	150A	100
1000V	225A	300 (BREAK only)

OPTIONS

TABLE 3. PRODUCT NOMENCLATURE

	CONTACT POLARITY	MOUNTING	COIL	AUXILIARY CONTACTS
RXC15	P Polarity Sensitive	3 PCB Mount	P 12V dual coil (economized)	A Normally Open
		9 Chassis Mount	Q 24V dual coil (economized)	B Normally Closed
			M 48V PWM coil (economized)	X None

PRODUCT DIMENSIONS [mm]

Mounting Option 3 – PCB Mount

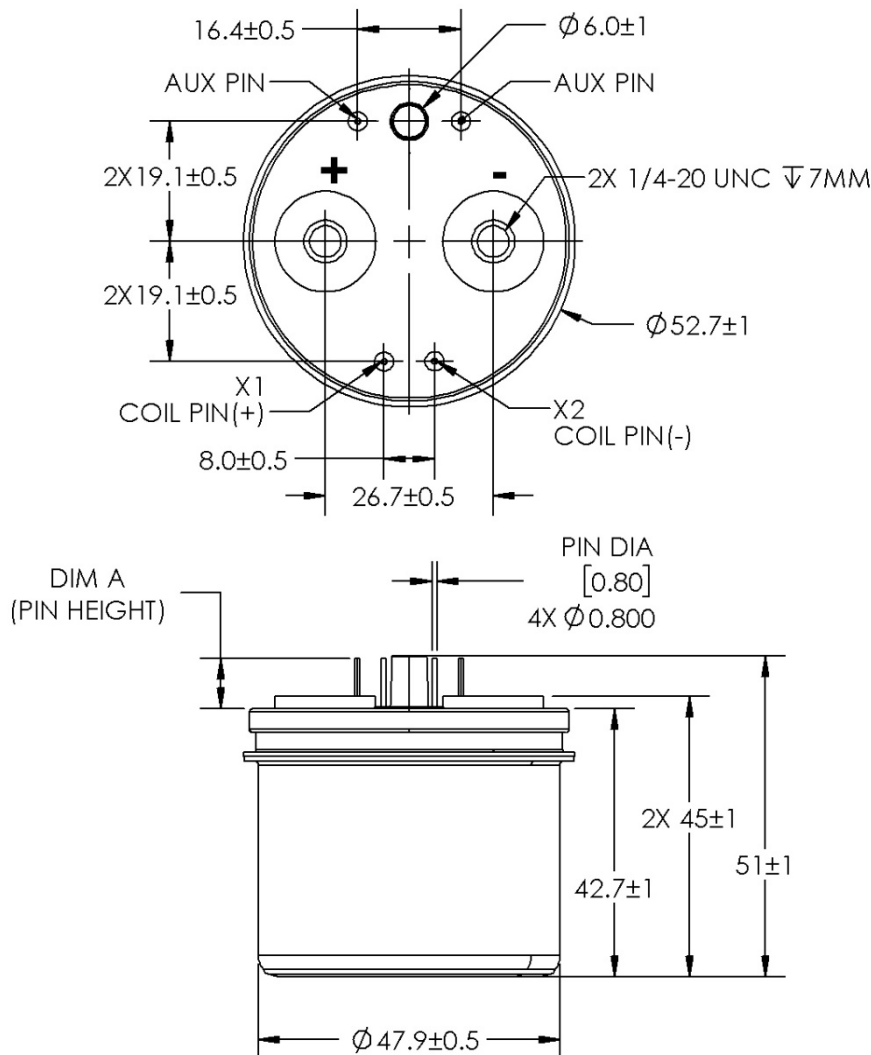

TABLE 4. DIMENSIONAL AND INSTALLATION PCB Mount

CHARACTERISTIC	MEASURE
Weight	290g (0.64 lb)
Coil Wire	N/A
Mounting Inserts	N/A
Mounting Position	Any / Not Position Sensitive
Package Quantity	TBD
Install Torque	7 Nm
1/4" – 20	7mm Thread Engagement
Main Terminals	



DIM A (PIN HEIGHT)	CONFIGURATION
4X 8.5 mm ±0.5 mm	WITH AUX CONTACTS (A, OR B)
2X 11.2 mm ±0.5 mm	WITHOUT AUX CONTACTS (X)

Mounting Option 9 – Chassis Mount

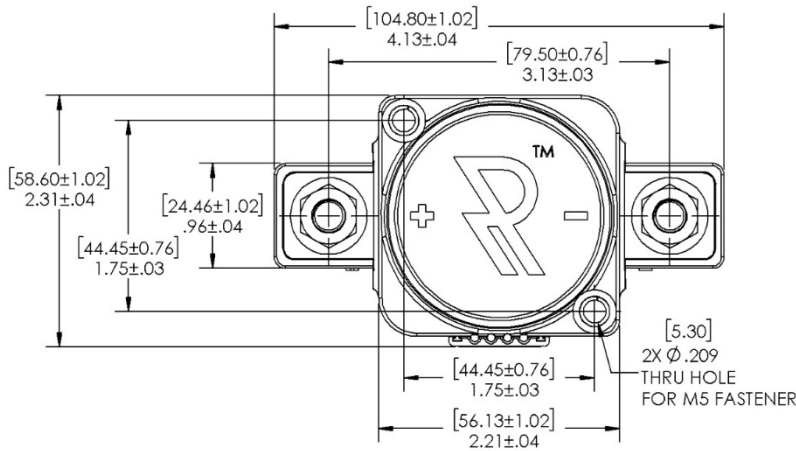
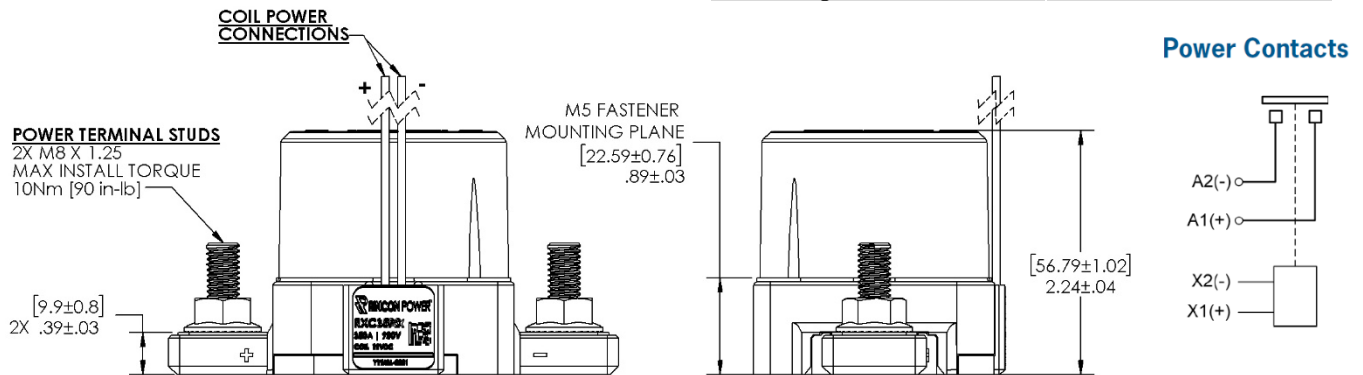

TABLE 5. DIMENSIONAL AND INSTALLATION

CHARACTERISTIC	MEASURE
Weight	450g (1.0 lb)
Mounting Inserts	M5
Mounting Position	Any / Not Position Sensitive
Package Quantity	20 pcs
Install Torque M8 x 1.5 Main Terminals	90 in-lb. [10Nm]
COIL / AUX WIRE	FUNCTION
Black	Coil GND (-)
Red	Coil POS (+)
Grey	Aux COM
Blue	Aux N.O.
Orange	Aux N.C.
Lead Wire Length	15 in [38 cm]
Lead Wire Size	20AWG, Stranded
Jacket Material	PVC
UL Ratings	UL 1007, UL 1569



- 3D model available upon request

NOTES

1. Attach cables and busbars directly to the main terminal pad using the recommended install torque. Do not use washers or other materials between the contactor power terminals and the conductor.
2. Contactor may be used above Max Switching Voltage if the application does not require significant load breaking. Please contact Rincon Power for more details.
3. Dual coil economizer design: Pickup Voltage must be applied as a pulse. Do not ramp voltage.
4. Integrated coil suppression limits back EMF to 150V.
5. Rigid busbar structures have the potential to induce stress into the device and can damage the hermetic seal. When using busbars, it is important to design compliance into the bus bar structure via the use of flexible laminated busbars and or by means of incorporating adjustability in adjacent bolted interfaces.
6. Polarity Sensitive versions are marked + and - for the power terminals. For applications that require the contactor to switch under load, please ensure current is flowing from the + to the - terminal when breaking/opening under load. For Bi-Directional versions the direction of current does not matter when breaking under load.
7. Avoid excessive coil voltages. Exceeding the ratings on the datasheet may result in high coil temperature and coil failure.

Legal Disclaimer Notice for Rincon Power, LLC Datasheet

This legal disclaimer applies to purchasers and users of products manufactured by or on behalf of Rincon Power, LLC ("Rincon"). Unless otherwise expressly indicated in writing, Rincon's products, product specifications and data sheets relating thereto are subject to change without notice. Users should check for and obtain the latest revision information and verify that such information is current and complete before placing orders for Rincon's products. Users should always verify the actual performance of the Rincon's products in their specific systems and applications.

Except as expressly set forth in the relevant purchaser order terms and conditions or applicable agreement, Rincon makes no warranty, representation or guarantee regarding the products, expressed or implied, including, but not limited to, a warranty of merchantability or fitness for a particular purpose. To the maximum extent permitted by applicable law, Rincon disclaims (i) any and all liability arising out of the application or use of any product, (ii) any and all liability, including without limitation special, consequential or incidental damages, and (iii) any and all implied warranties, including warranties of fitness for particular purpose, non-infringement and merchantability.

In no event shall Rincon be liable for any incidental or consequential damages resulting from the use, misuse or inability to use the product. This exclusion applies regardless of whether such damages are sought based on breach of warranty, breach of contract, negligence, strict liability in tort, or any other legal theory.