

# 5 DIGITAL MICRO-PROCESS TEMPERATURE (THERMOCOUPLE) ISOLATED TRANSMITTER



## FEATURES

- Accuracy:  $\pm 0.2\%$  F.S.  $\pm 0.5^\circ\text{C}$  (Cold junction compensation)
- Measuring Temperature (TC) sensors for K, J, E, R, S, B, T
- Measuring sensor disconnection
- High brightness 0.4" LED display range: -19999~99999; 1 decimal point selectable
- $^\circ\text{C}/^\circ\text{F}$  unit selectable
- Surge test of AC 2000V / min between input / output / power
- High stability, non-flammable case (PC), high safety

## ORDER INFORMATION: ATM-T - Code 1 - Code 2 - Code 3

Code 1	Input Type	Code 2	Aux. Power	Code 3	Analog Output
B	200~1800 $^\circ\text{C}$	A	AC/DC 100~240V	1	4~20mA
E	-185~900 $^\circ\text{C}$	D	AC/DC 22~60V	2	0~20mA
J	-200~200 $^\circ\text{C}$	O	Option	3	0~5V
K	-200~1360 $^\circ\text{C}$			4	0~10V
R	0~1760 $^\circ\text{C}$			L	LoopPower: 15~30 Vdc 4~20 mA
S	0~1750 $^\circ\text{C}$			O	Option
T	-200~395 $^\circ\text{C}$				
O	Option				

## SPECIFICATION

- ◆ Accuracy:  $\pm 0.2\%$  F.S.  $\pm 0.5^\circ\text{C}$  (Cold junction compensation)
- ◆ Display Screen: High brightness red LED; 10.16mm (0.4")
- ◆ Display Range: -19999~99999
- ◆ Zero Adjustment:  $\pm 9999$
- ◆ Span Adjustment:  $\pm 9999$
- ◆ Over Range Indication: doFL / ioFL or -doFL / -ioFL
- ◆ Polarity Indication: Automatic with "-" indication
- ◆ Disconnection Indication: Automatic with "OPEn" indication
- ◆ Parameters Setting: Push buttons
- ◆ Back Up Memory: EEPROM
- ◆ Analog Output Resolution: 15 bit
- ◆ Output Response Time: <250 msec (0~90%)
- ◆ Output Capability: Voltage Output: <20mA  
Current Output: <10V
- ◆ Output Ripple:  $\leq \pm 0.1\%$  F.S.
- ◆ Isolation: Input / Output / Power / Case
- ◆ Temperature Coefficient: 100ppm /  $^\circ\text{C}$  (0~60 $^\circ\text{C}$ )
- ◆ Operating Temperature: 0~60 $^\circ\text{C}$
- ◆ Operating Humidity: 20~90% RH (non-condensing)
- ◆ Storage Temperature: -10~70 $^\circ\text{C}$
- ◆ Storage Humidity: 20~90% RH (non-condensing)
- ◆ Power Supply: AC/DC 100~240V; AC/DC 22~60V
- ◆ Surge Test: 2KVac / 1min
- ◆ Insulation Resistance: >100M $\Omega$  with 500Vdc
- ◆ Input Impedence: Voltage: >2V for 20K $\Omega$  / V;  $\leq 2\text{V}$  for >200M $\Omega$   
Current:  $\geq 0.2\text{A}$  at 100mV; <0.2A at 1V
- ◆ Installation: Socket / Plug in

## FRONT PANEL & KEY FUNCTIONS

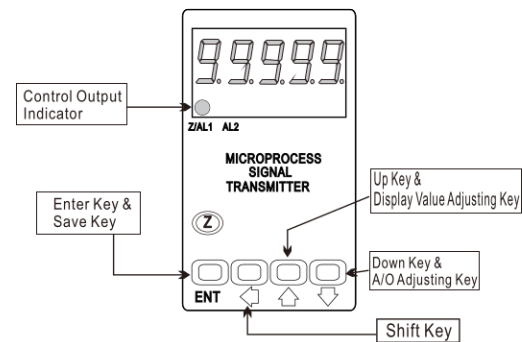

## DIMENSION

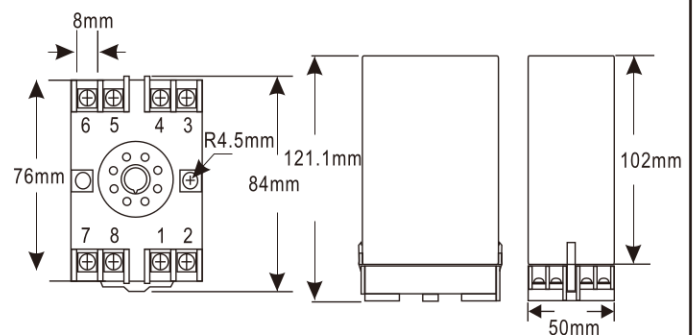

## WIRING CONNECTION

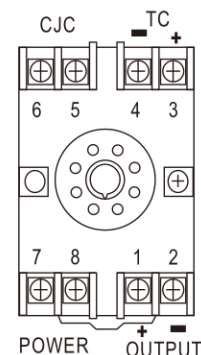

\* Please understand key indicators & functions at the first operation.

FRONT PANEL & KEY FUNCTIONS

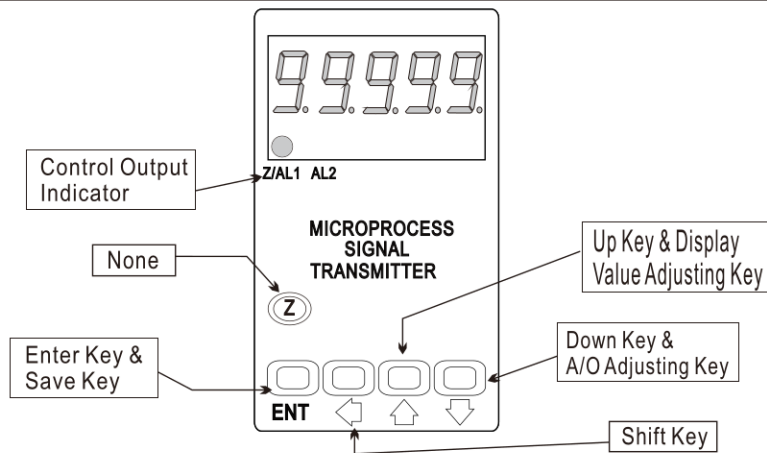

Key Name	Symbol	Descriptions
Enter Key & Save Key	ENT	1. In the measuring status, press this key can enter to parameter pages. 2. In the parameter setting, press this key can save the value & go to next page.
Shift Key	←	1. In the parameter setting, press this key can move the cursor left.
Up Key & Display Value Adjusting Key	↑	1. In the measuring status, press this key for 3 sec can enter to display adjustment of "ZERO" & "SPAN" 2. In the parameter setting, press this key can increase the digits.
Down Key & A/O Adjusting Key	↓	1. In the measuring status, press this key for 3 sec can enter to analog output adjustment. 2. In the parameter setting, press this key can decrease the digits.

- \*\*1. The following block charts are parameters codes, parameter codes & parameters will alternate flashing if the parameters can be modified.
- 2. To modify the parameters, please press ← ↑ ↓, and press ENT to save the parameters after the modification.
- 3. Please don't forget the new pass code after modification.
- 4. In any pages, press ↑ & ↓, or don't press any keys for 2 minutes that will back to measuring status.

GENERAL MODE OPERATING PROCEDURES

Block Charts	Display	Descriptions	Default
Power On		Display : "ZERO" & "SPAN" Adjustment	
	Measuring Status	Present value for measurement.	
	Display (dZEro) Adjustment (dZEro)	Press ← to select adjusting speed rate, press ↑ ↓ to modify the zero value. PS: To use this function to adjust the real zero value.	00000
	Display Span Adjustment (dSPAN)	Press ← to select adjusting speed rate, press ↑ ↓ to modify the span value. PS: To use this function to adjust the real span value.	00000
		Analog Output: "ZERO" & "SPAN" Adjustment	
	Measuring Status	Present value for measurement.	
	A/O Zero Adjustment (AZEro)	Press ← to select adjusting speed rate, press ↑ ↓ to modify the A/O zero. PS: To use this function to adjust the real A/O zero.	00000
	A/O Span Adjustment (ASPAn)	Press ← to select adjusting speed rate, press ↑ ↓ to modify the A/O span. PS: To use this function to adjust the real A/O span.	00000

## PROGRAMMING MODE OPERATING PROCEDURES

Block Charts	Display	Descriptions	Default
Power ON ↓ 10000	Measuring Status	Present value for measurement.	
Press: ENT ↓ P.Cod	Pass Code (P.Cod)	Press ◀ ▶ ↻ to enter pass code.	00000
Press: ENT ↓ P.Code Correct NO YES		Pass code is correct that will enter to parameter groups. Pass code is wrong that will back to measuring status.	
Press: ENT ↓ 5YS	System Setting Page (SYS)	Press ◀ can select A/O setting page.	
Press: ENT ↓ tYPE	Input Type Setting (tYPE)	Press ◀ ▶ to modify the input type.	
Press: ENT ↓ dP	Decimal Point Setting (dP)	Press ◀ ▶ to select decimal point (0, 1). EX: if the value shows "0.0" that means the decimal point is 1 digit.	00000
Press: ENT ↓ unit	Temperature Unit Setting (Unit)	Press ◀ ▶ to modify the unit of linear-speed (°C/°F).	°C
Press: ENT ↓ CJC	Cold Junction Compensation (CJC)	Press ◀ ▶ can switch (on) or (off) cold junction compensation.	no
Press: ENT ↓ AvG	Display Average Setting (AvG)	Press ◀ ▶ to modify display average (1~99). PS: Please use this function for stable display value when input signal is unstable.	00020
Press: ENT ↓ CodE	Pass Code Setting (CodE)	Press ◀ ▶ to modify pass code (0~19999). PS: Please don't forget the new pass code after modification.	00000
Press: ENT ↓ LoCK	Key Lock Setting (LoCK)	Press ◀ ▶ to lock the keys, using key lock function only can view the parameters, but cannot modify any values. PS: no (unlock), YES ("ENT" unlock, others lock).	no
Press: ENT ↓ AoP	A/O Setting Page (AoP)	Press ◀ can select A/O setting page.	
Press: ENT ↓ PoLAr	A/O Polarity Setting (PoLAr)	Press ◀ ▶ to modify output is positive pole or negative pole. PS: Voltage output, NO: positive pole output (0~+10V) YES: positive & negative pole output (-10~+10V)	no
Press: ENT ↓ AnLo	A/O Low Scale Setting (AnLo)	Press ◀ ▶ to adjust A/O low scale to correspond to the display value. EX: A/O is 0~10V, the display is 10.0 to output 0V, this value must be set for 10.0.	00000
Press: ENT ↓ AnHi	A/O Hi Scale Setting (AnHi)	Press ◀ ▶ to adjust A/O hi scale to correspond to the display value. EX: A/O is 0~10V, the display is 90.0 to output 10V, this value must be set for 90.0.	99999

### Error Code of Self-Diagnosis

Display	Descriptions	Display	Descriptions
coFL	Cold junction is over sensor's (PT100) measuring range (0~100°C).	doFL	Input signal is over display range (99999)
-coFL	Cold junction is under sensor's (PT100) measuring range (0~100°C).	-doFL	Input signal is under display range (-19999)
oPEr	Input signal or cold junction is disconnection.	E-00	EEPROM reading /writing suffers the interference (about 1 million times)

\*\*Please check the wiring connection is correct first, if the problem still exist, please return the meter to the factory.

### CALIBRATION OPERATING PROCEDURES

Block Charts	Display	Descriptions	Default
10000 Press: ENT & ◀ together for 3 sec	Measuring Status	Present value for measurement Press ENT & ◀ together for 3 sec will enter to calibration operating procedures.	
↓ 1nLo	Input Low Scale Calibration (inLo)	1. Input standard low scale signal. 2. Press ◀ ▶ to calibrate input low scale.	
Press: ENT ↓ 1nHi	Input Hi Scale Calibration (inHi)	1. Input standard hi scale signal. 2. Press ◀ ▶ to calibrate input hi scale.	
Press: ENT ↓ 5YS	System Setting Page (SYS)	1. Finish calibration operating procedures will enter to system setting group. 2. Press ◀ ▶ together to back to measuring status.	

**Warning: Calibration of this meter requires a standard signal with 0.01% accuracy or better and an external meter with 0.005% accuracy or better.**