

52-08 rocker pin

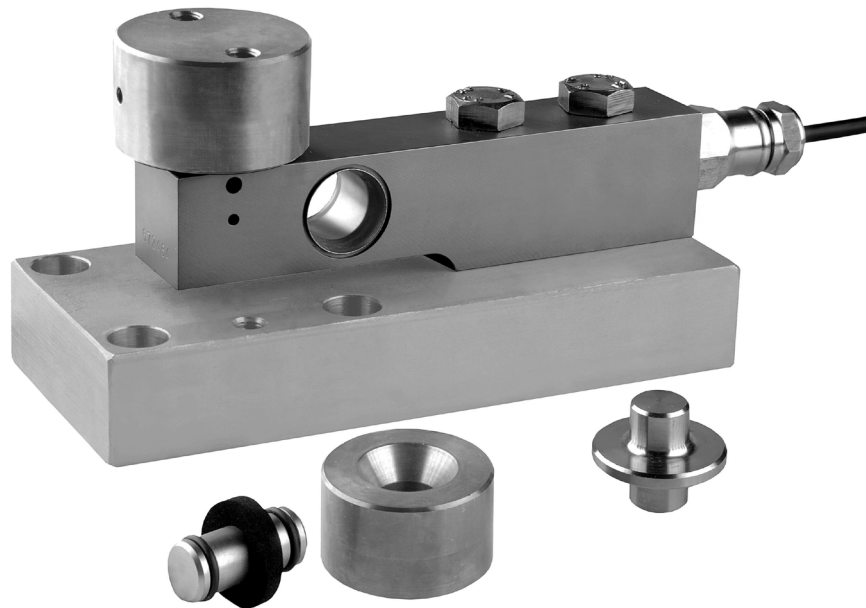

product description

The rocker pin assembly – model 52-08 – is a rugged system for ensuring optimum load introduction to a range of Flintec beam load cells. Ideal for high capacity platform scale and hopper scale applications. Constructed from stainless steel. Especially designed for the SB4, SB5, SLB, SB9 and SB14.

The image depicts the 52-08 rocker pin and SB4 load cell combined with base plate 52-00.

applications

Industrial platform scales, low capacity vessel weighing systems.

key features

Low profile

Blind hole load introduction

Stainless steel construction

Suitable for a wide range of beam load cells from 100kg to 10,000kg

W&M certified

accessories

[Installation guide pin](#)



product dimensions (mm)

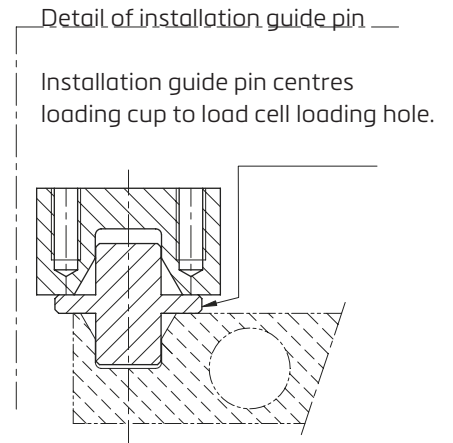
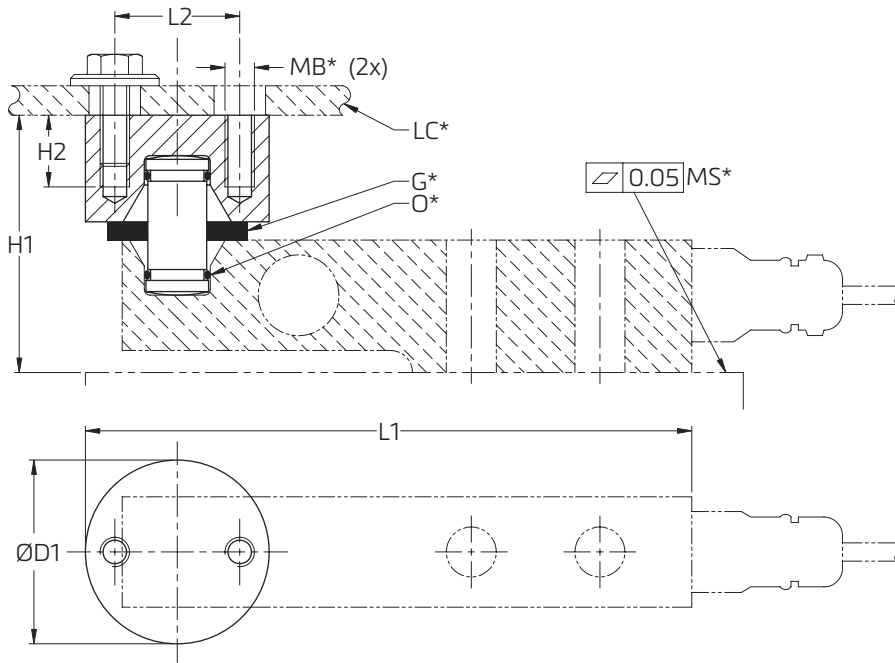

Note:
Bumper stops are required.
Gap approx. 2...3 mm.
A special part is available with
integrated bumper stops



- MB* - Mounting bolts D2
- LC* - Load carrier
- G* - Gasket
- O* - O-ring
- MS* - Load cell mounting surface

Load Cell Type	Capacity	L1	L2	H1	H2	D1	Mounting bolts D2
SLB / SB9	0.2...5 klb (91...2268 kg) / 250...2000 kg	149	34	66*	16	50	M8
SB14	0.5...1klb (227...454 kg)			65			
	2.5...5 klb (1134...2268 kg)			67*			
	10 klb (4536 kg)	189	44	85	20	60	M10
SB4 / SB5	5...20 kN (510...2039 kg)	165	34	70	16	50	M8
	50 kN (5099 kg)	199	44	90	20	60	M10
	100 kN (10197 kg)	250	50	115		68	

* Including spacer
Restoring force: approx. 3% of actual load / mm lateral displacement of load introduction.
CAD files for customer's own application drawings are available for download from the Flintec homepage.

details of SLB load cell

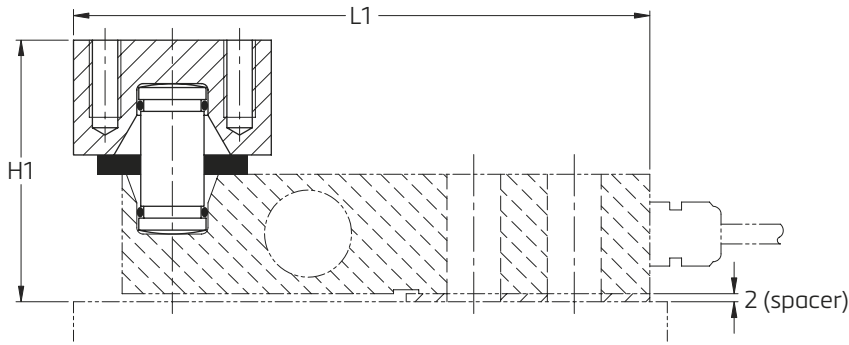

example setups

Platform or hopper scale with 4 load cells

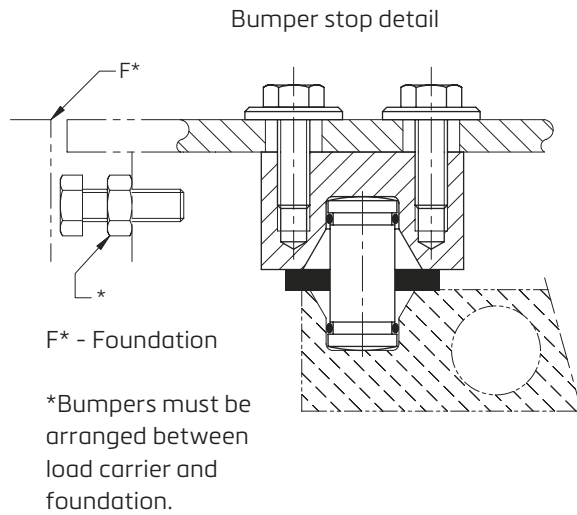
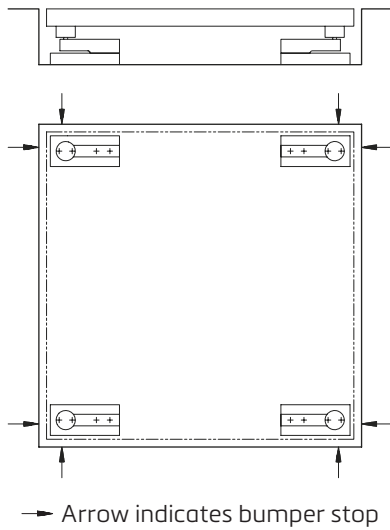

Specifications and dimensions are subject to change without notice.