

# Weigh Modul 55-20

---

## APPLICATION GUIDELINE



Flintec GmbH  
Bemannsbruch 9  
DE 74909 Meckesheim  
GERMANY

[www.flintec.com](http://www.flintec.com)



## Table of content:

1. Brief product description .....	3
2. Pre- assembled weigh module .....	3
3. Dimension [mm] .....	4
4. Datas.....	4
5. Installation .....	4
6. Additional structure with washers and spacers.....	7

# 1. Brief product description

Type 55-20 weigh modul is designed for load cell RC3 and RC3D. It is a self-aligning weigh modul with excellent load introduction and lift off protection.

The modul is especially for using in hopper, tank and silo weighing applications. The modul incorporates an integrated bumper stop eliminating the need of using check links thereby offering highest possible precision.

All moduls are identical so they can be implemented in selectable orientation.

Standard version:

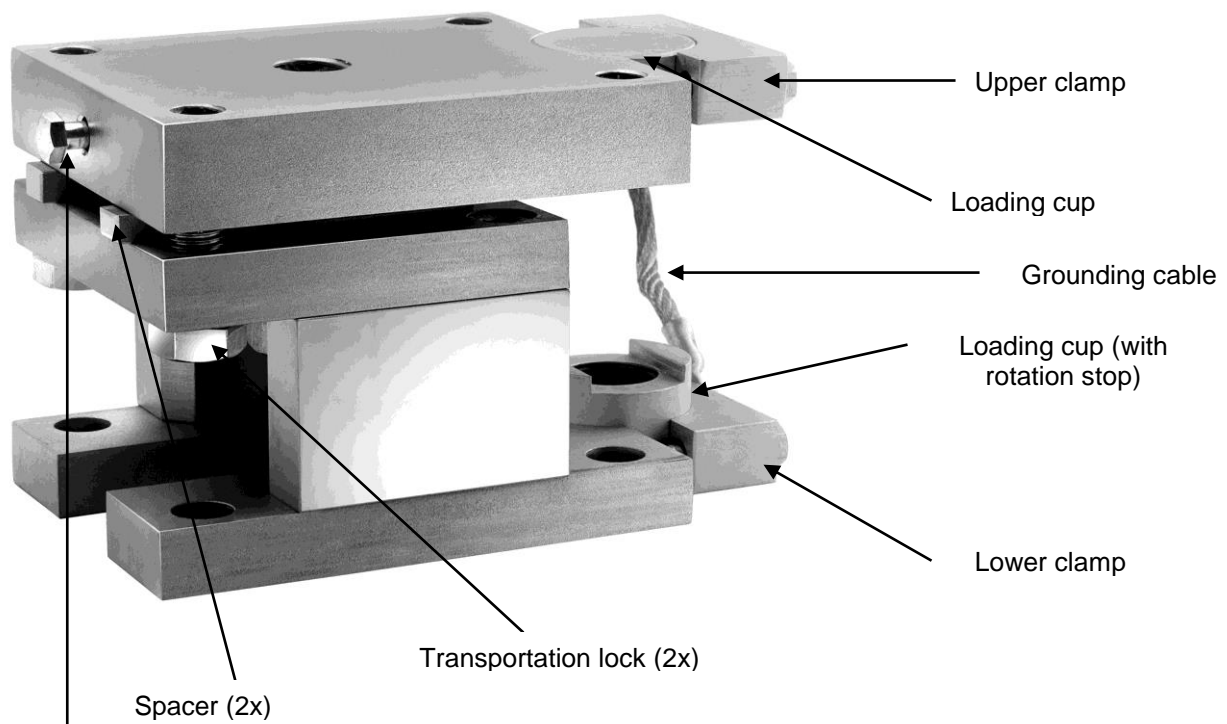
- Capacity 7,5....100 t; mild steel, zinc plated (material S355JR, No. 1.0045)
- Capacity 150...300 t; cast mild steel, painted

The modul will be shipped completely pre-assembled; ready for installation by welding or bolting\*.

55-20 can preferably be welded to tank foot and foundation plate. This eliminates problems of getting holes on top and welded on bottom.

**\*Note:** The mounting screws are not included in the scope of delivery.

# 2. Pre- assembled weigh module



Safety srew for bumpers and lift of protection

**Picture 1:** 55-20 weigh module, scope of delivery without RC3/RC3D load cell.

### 3. Dimension [mm]

Picture 2: Dimensions

Capacity	D1	D2	H1	H2	H3	H4	H5	L1	L2	L3	L4	L5	L6	L7
7,5 ... 22,5t	50	17,5	133	130	20	30	10	166	160	130	25	100	93	90
30 ... 40 t	60	22	204	200	28	40	12,5	210	210	170	30	125	120	115
50 ... 100 t	85	26	254	250	34	50	15	250	250	200	45	165	150	145
150 t	110	33	305	300	40	60	20	300	290	230	60	205	180	175
300 t	135	39	405	400	60	70	25	370	350	280	65	235	215	205

Capacity	S1	S2	S3	T1	T2	W1	W2	W3	W4	Q1 [Nm]	Q2 [Nm]	X	Y
7,5 ... 22,5t	8	5	5	M24	M16	130	130	100	80	200	15	6	4
30 ... 40 t	12	8	6	M30	M20	150	150	110	100	400	35	8	6
50 ... 100 t	12	8	7	M36	M24	200	200	150	130	700	35	12	7
150 t	15	10	8	M42	M30	260	250	190	160	1300	60	15	8
300 t	15	10	10	M56	M36	320	300	230	200	2300	140	20	10

### 4. Data

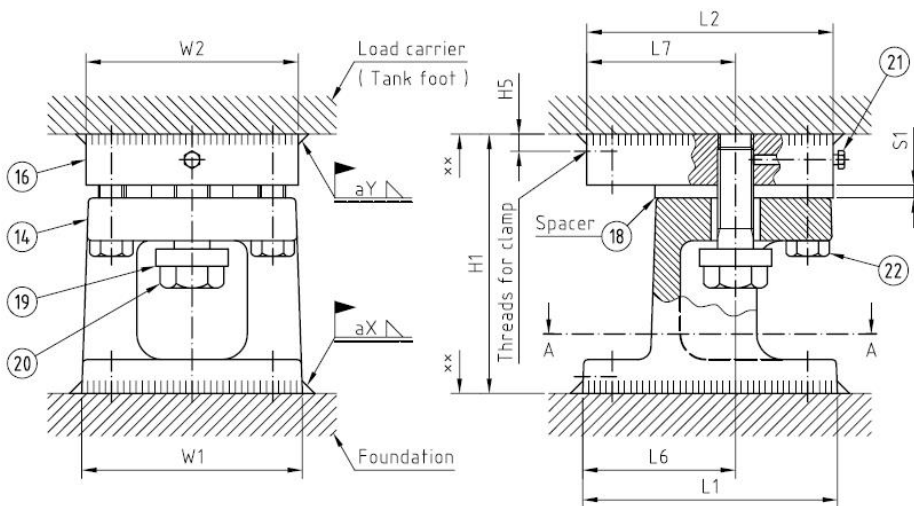
Capacity	Weight[kg] without load cell	Max. Force [kN]	
		Lift off protection 1) 3) 4)	Side bumper 2) 3) 4)
7,5 ... 22,5t	15	100	50
30 ... 40 t	33	180	90
50 ... 100 t	65	300	150
150 t	113	400	200
300 t	225	600	300

- 1) The effective lifting force is applied worst case on ONE module.
- 2) Hopper and tank weighing with 3 or 4 weighing modules installed assumes that actual lateral forces (wind) distribute evenly over at least 2 modules.
- 3) By using the optional stainless steel (No. 1.4301) version, max. forces are reduced to 60 % of given values.
- 4) For structural calculations in case of earthquake, minimum break loads are increased to 200% of lift-off forces and 250% of side bumper forces.

### 5. Installation

1. The mounting surfaces must be horizontal and flat. Only suitably prepared mounting surfaces ensures that in subsequent weighing a sufficient accuracy is achieved.
  - Maximum horizontal deviation 0,5° (8 mm / m) for industrial application
  - Maximum horizontal deviation 0,2° (4 mm / m) legal for trade application
2. All pre-assembled weighing modules are positioned on the base. The transport locks remain initially mounted.
  - **Note:** Please make sure that in the later weighing the loads are vertical and torque-free introduced into the load cells (force F, see Figure 4 and 5).
3. The load carrier is placed (see Figure 3).
4. All weighing modules are successively welded to the foundation and the load carrier (see Figure 3). Alternatively, also screwed (see Figure 5)
  - The standard weighing module to capacity 100 t is made of material S355JR (material no. 1.0045)
  - Before welding all paint and coating **must** be removed in the area of the planned weld.
  - Prior to welding, heat the material to a temperature of 150 ... to 200 ° C
  - After welding, the weld must be cleaned and primed. Then a protective varnish (RAL 1003) is applied to the affected areas.

5. For each weighing modules in sequence: Please remove the clamps and the loading cups. Than grease the O-rings and the contact surfaces in the loading cups and assemble it with the load cell. Subsequently, the load cell is inserted with the loading cups in the intended position in the weighing module. The lower clamp is mounted and screwed. The upper clamp is mounted, but still not tightens bolts.
  - **Note:** When used in vehicle scales, make sure that the cable outlet of the weighing cell ALWAYS runs transversely to the direction on the scale.
6. The transport safety screws on all weighing modules have to be removed (see Figure 3 Pos. 22). The gap between the washer (Pos. 19) and module base (Pos. 14) must be checked and adjusted to the size of about 10 mm.
7. For each weighing modules in sequence: To remove the spacer (Pos.18) lift off the load carrier 1...3mm. The lift off is preferably performed by using a hydraulic lifting device in an appropriate location in the immediate vicinity of the weighing module. Lower the load carrier on the load cell and remove the lifting device. Now the fixing bolts are tightened to the upper clamping bracket. The gap of the safety screw (item 20) must be set to 1 ... 3 mm and then to back up (see picture Pos.3 locking screw 21; Tightening torque Q2 see table in Figure 4). Step 7. perform all weighing modules sequentially.
8. For very stiff load carriers and more than 3 weighing modules it may be necessary to establish a uniform load distribution on all weighing modules by means of spacer plates. If this is required, so this step should be planned and prepared prior to installation (see also Chapter 6: Additional Propping with washers and spacers). It is recommended that you install on each weighing module the included grounding cable.



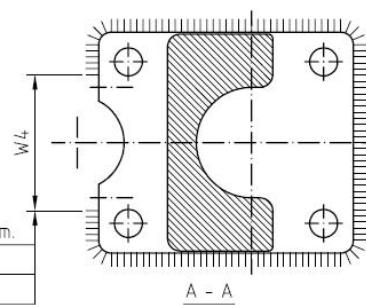
**Figure 3:**  
Pre-mounted weighing module,  
positioned on site and welded  
to the base and the load carrier

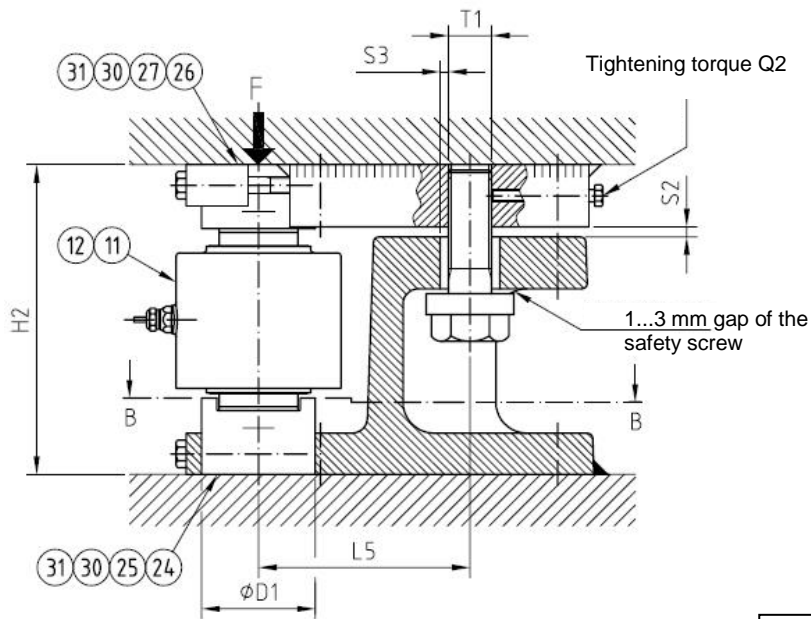
Capacity	Weld	
	X mm	Y mm
7,5...22,5t	6	4
30...40 t	8	6
50...100 t	12	7
150 t	15	8
300 t	20	10

Dimension chapter 3

NOTE:  
xx Mounting surfaces machined  $\frac{6.3}{\sqrt{}}$   
and horizontal within 0.4/100.

No weld here at top and bottom.  
Surface within dimension W4  
protected. Also see note 2.

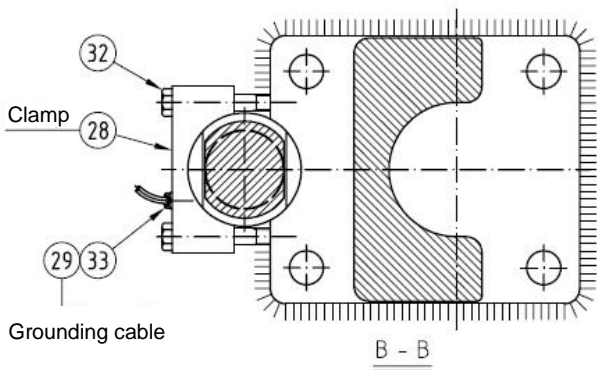




**Figure 4:**  
Weighing module already installed,  
mounting by welding

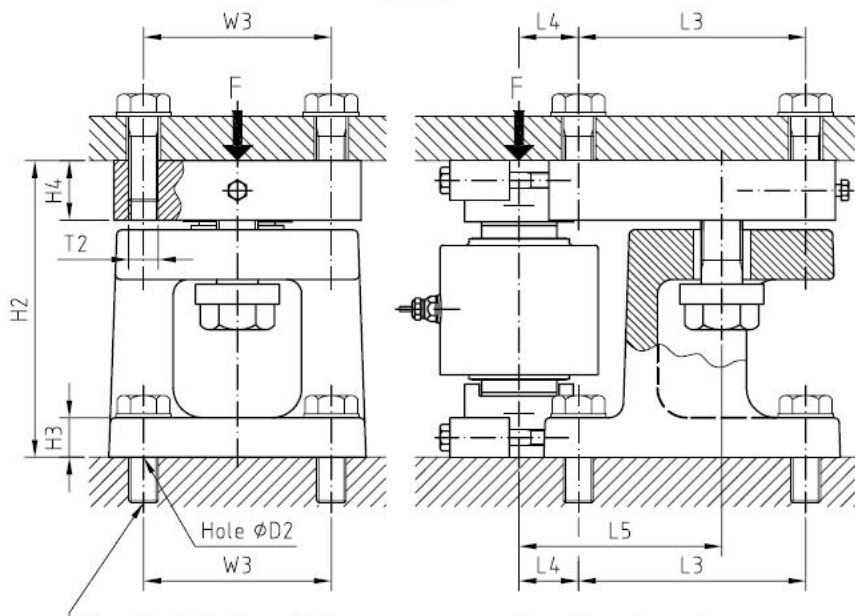
Capacity	Q2 [Nm]
7,5...22,5t	15
30...40 t	35
50...100 t	35
150 t	60
300 t	140

Dimension chapter 3



**Note:**

The weighing module must be operated under any circumstances without functioning bondage! The bondage is (see Figure 3) ensured by the proper assembly of the parts 19, 20 and 21.



**Figure 5:**  
Installed bolted weighing module,

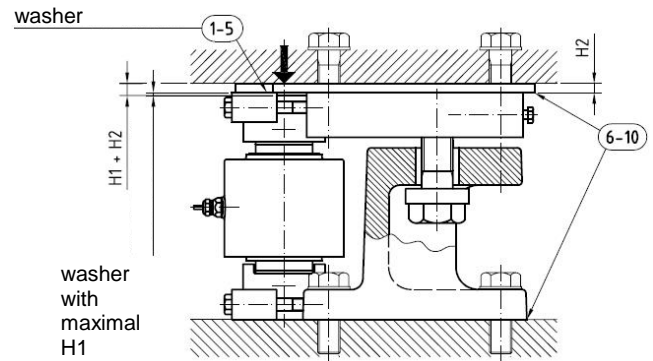
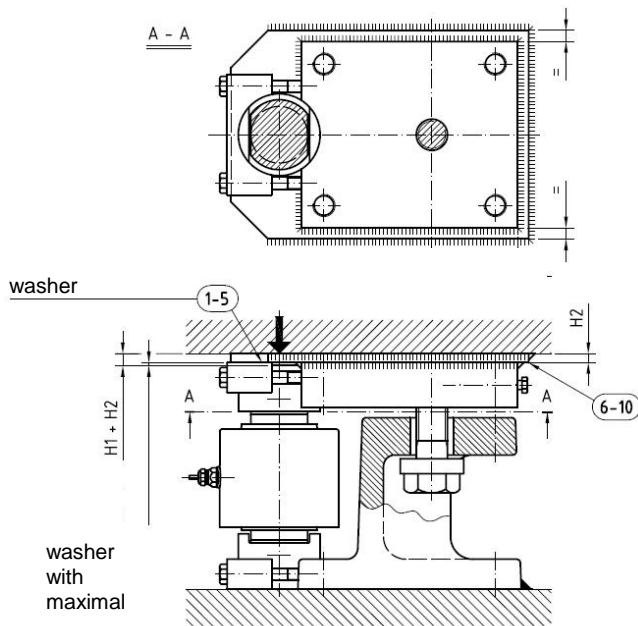
Capacity	Q1 [Nm]
7,5...22,5t	200
30...40 t	400
50...100 t	700
150 t	1300
300 t	2300

Dimension table 3

Mounting screws (4x above 4x below)  
Thread T2, quality 8.8, tightening torque Q1  
(not included in the scope of delivery)

Further dimensions see  
Figure 1 and 2

## 6. Additional structure with washers and spacers



Capacity	Max. H1 [mm]	H2 [mm]
7,5...22,5t	2	6
30...40 t	4	10
50...100 t	4	10
150 t	6	12
300 t	6	15

**Figure 6:** Welded weighing module

**Figure 7:** Bolted weighing module

1. The Propping is only for balances with more than 3 weighing modules and at the same time very stiff load carriers required so that a fine adjustment is needed to produce a uniform load distribution over all weighing modules.
2. Must be a maximum of one corner to the extent underpinned max H1; with washers (diameter slightly smaller than D1 choose not supplied). If necessary may at the diagonally opposite corner also a washer are underpinned up to the level max. H1.
3. Is the need for propping higher than the height max. H1, then (Figure 6) (not supplied) placed an additional spacer plate for welded module. If necessary may at the diagonally opposite corner also a spacer plate (not included) will be launched.
4. Additional spacer plates may in required quantity (not included) for the screw weighing module (Figure 7) above and are supplemented below.

[www.flintec.com](http://www.flintec.com)