

PC3H welded single point load cell

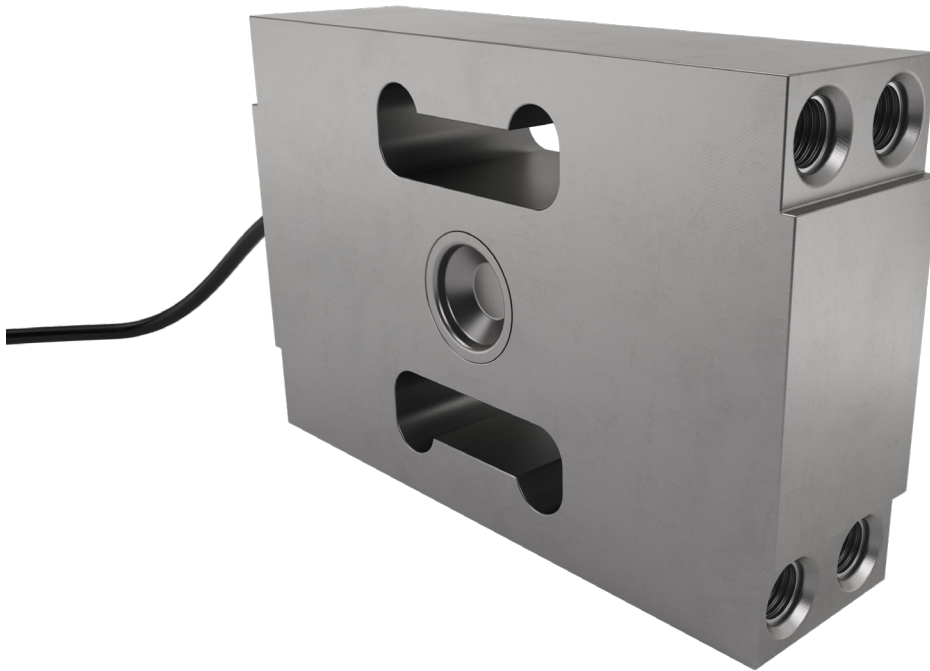

product description

The PC3H is designed for front-end bin lifting systems on waste collection vehicles. Its high capacity of 5t means that one load cell per lifting fork can be used instead of the normal arrangement of two.

Virtually shock proof, the PC3H has proven to be the most rugged single-point load cell available to designers and manufacturers of on-board weighing systems. It's fully hermetically sealed and constructed from the toughest stainless steel.

Alternative load cell sizes and bolt-hole configurations are available in the Flintec bin-lift load cell range – see our PC2H, PC5H, PC6H and PC7H single point load cells.

applications

Front end (FEL) bin lifting systems for waste collection vehicles (RCV's).

accessories

Compatible range of electronics

key features

Capacity of 5,000kg

Stainless steel construction with a bead-blasted surface

Hermetically sealed to IP68/IP69K

Very rugged construction

Off-centre load adjusted

High accuracy

approvals

OIML approval to C2.5 (Y=12,000)

NTEP approved to 2,500 intervals, Class III, single cell applications



RoHS
compliant



specifications

Maximum capacity (E_{max})	kg	5,000		
Minimum dead load	kg	0		
Accuracy class according to OIML R60	-	GP	C1	C2.5
Maximum number of verification intervals (n_{LC})	-	-	1,000	2,500
Minimum load cell verification interval (v_{min})	-	-	$E_{max}/12,000$	$E_{max}/12,000$
Temperature effect on minimum dead load output (TC_0)	% RO/10°C	±0.040	±0.016	±0.012
Temperature effect on sensitivity (TC_{RO})	% RO/10°C	±0.0500	±0.030	±0.014
Combined error	% RO	±0.0500	±0.030	±0.024
Non- linearity	% RO	±0.0500	±0.030	±0.020
Hysteresis	% RO	±0.0500	±0.030	±0.020
Creep error (30minutes)/ DR	% RO	±0.0500	±0.049	±0.020
Rated Output (RO)	mV/V	0.90 ± 0.1%		
Calibration in mV/V/Ohm	%	≤± 0.05		
Zero Balance	% RO	< ± 5		
Excitation Voltage	V	5...15		
Input Resistance (R_{LC})	Ω	1,100 ±50		
Output Resistance (R_{OUT})	Ω	1,000 ±50		
Insulation Resistance (@100v DC)	MΩ	>5,000		
Safe load limit (E_{lim})	% E_{max}	200		
Ultimate load	% E_{max}	400		
Safe side load limit	% E_{max}	100		
Maximum off centre loading effect	% RO/mm	± 0.00006		
Maximum off centre distance at maximum capacity	mm	500		
Compensated temperature range	°C	-10 ... +40		
Operating temperature range	°C	-40 ... +80		
Load cell material	-	Stainless steel 17-4PH (1.4548)		
Sealing	-	Complete hermetic sealing; cable entry sealed by glass to metal header		
Humidity class	-	CH		
Protection According to EN60 529	-	IP68 (up to 2m water depth) / IP69K		
Weight	kg	13.5 (approx)		

The limits for Non Linearity, Hysteresis and TC_{RO} are typical values.

The sum of Non Linearity, Hysteresis and TC_{RO} meet the requirements according to OIML R60 with $p_{LC} = 0.7$

product dimensions (mm)

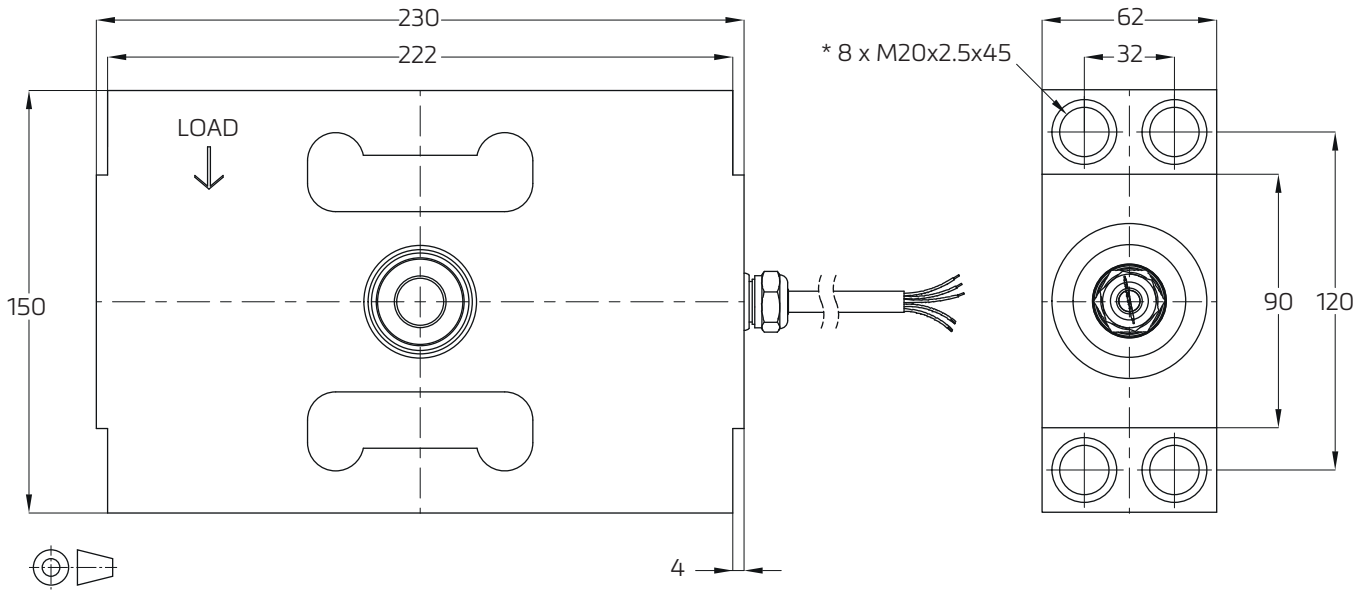

*Mounting bolts are M20 with 2.5mm pitch and 45mm deep. (x8)

We recommend a bolt class of 10.9 torqued to 570Nm.

A bolt class of 12.9 torqued to 670Nm is recommended for high dynamic loads.

(Values assumes oiled thread.)

wiring

The load cell is provided with a shielded, 4 conductor cable (AWG 20)

Cable jacket: thermoplastic rubber

Cable length: 5 m

Cable diameter: 7.6 mm

The shield is floating

* Optional grounded shield at cable gland

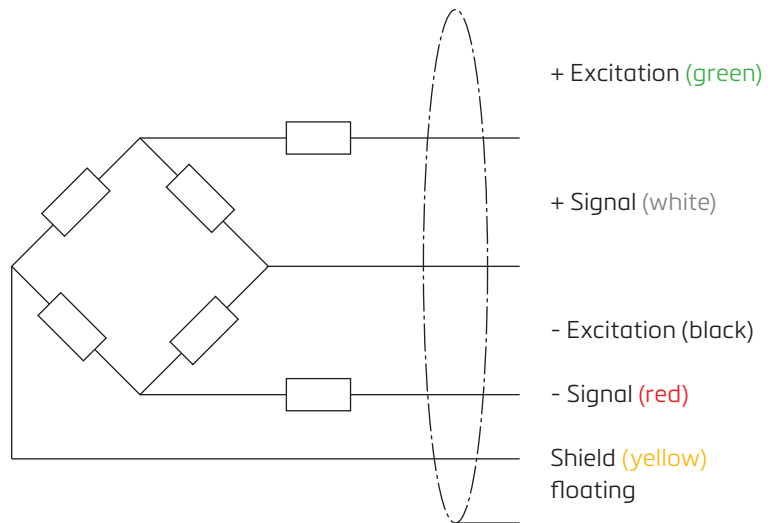

Specifications and dimensions are subject to change without notice.