

# MBC thru-hole force transducer



## product description

The MBC is a series of miniature force transducers designed for applications in general test and measurement as well as machine monitoring and control.

The low profile, small diameter design enables the MBC to be easily embedded into machinery or test equipment – ideal for packaging machinery, assembly machinery or end-of-line test equipment.

Available in a wide range of standard capacities from 100lb through to 50klb; the MBC is configured for compression force measurement acting on cylinders, bolts or shafts. A range of internal thru-hole diameters are available. Full-bridge, bonded foil strain gauge technology provides excellent long-term stability and ensures high performance even in applications requiring in excess of 1 million load cycles. Constructed from stainless steel and protected from moisture with an epoxy bonded cover.

The MBC comes with standard cable configurations or with industry standard connectors. As an additional aid to system integrators, the MBC can be supplied as a TEDS (Transducer Electronic Data Sheet) enabled smart transducer this provides an on board memory chip storing manufacturing and calibration data.

Comprehensive range of electronic modules and accessories are available.

## applications

General test and measurement as well as machine monitoring and control. Ideal for packaging machinery, assembly machinery or end-of-line test equipment.

## key features

---

Capacity range of 100lb to 50klb

---

Stainless steel construction

---

Environmental protection to IP65

---

High accuracy  $\pm 0.25\%$

---

Low profile, small diameter and low weight design

---

Temperature compensated from  $-10^{\circ}\text{C}$  to  $+40^{\circ}\text{C}$

## options

---

Range of cable lengths

---

Flying leads or cable connectors

---

TEDS IEEE 1451.4 memory chip

---

Multi-point calibration available



## specifications

Maximum Capacity ( $E_{max}$ )	lb	100/250/500/1,000/2,000/3,000/5,000/10,000/ 15,000/20,000/30,000/50,000
Rated Output (RO)	mV/V	2 Nom
Non-Linearity	%RO	$\leq \pm 0.250$
Hysteresis	%RO	$\leq \pm 0.250$
Temperature effect on minimum dead load output	%RO/°C	$\leq \pm 0.018$
Temperature effect on sensitivity	%RO/°C	$\leq \pm 0.009$
Excitation Voltage	V	5...10
Zero Balance	%/°C	$\leq \pm 5.0$
Input Resistance	$\Omega$	700 Nom
Output Resistance	$\Omega$	700 Nom
Insulation Resistance (100 V DC)	M $\Omega$	$\geq 5,000$
Compensated Temperature Range	°C	-10...+40
Operating Temperature Range	°C	-40...+90
Safe Load Limit ( $E_{lim}$ )	% $E_{max}$	150
Ultimate Load	% $E_{max}$	300
Safe Side Load	% $E_{max}$	100
Load Cell Material	-	Stainless Steel 17-4 PH
Protection according to DIN 40.050	-	IP65

## wiring

The sensor is provided with a 28AWG  
4-conductor braided shield

Standard cable jacket: grey polyurethane

Standard cable length: 3 m

Optional 30AWG 4-conductor braided shield,  
white Teflon jacket.

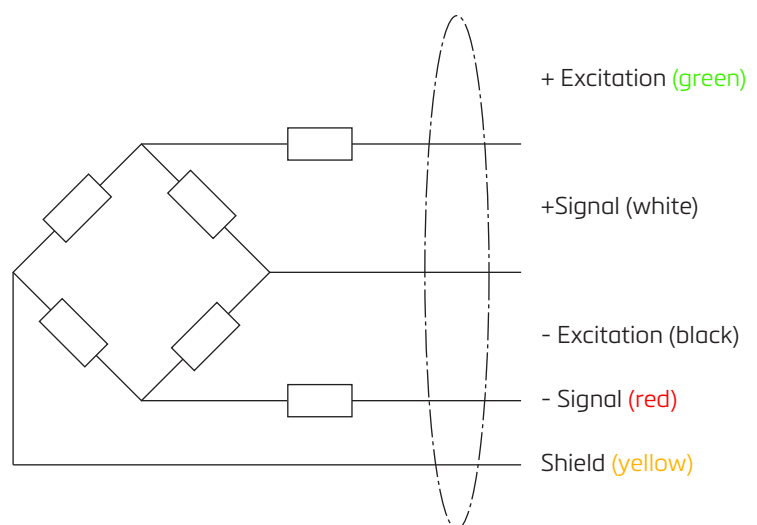

product dimensions for 100lb - 5klb models (mm)

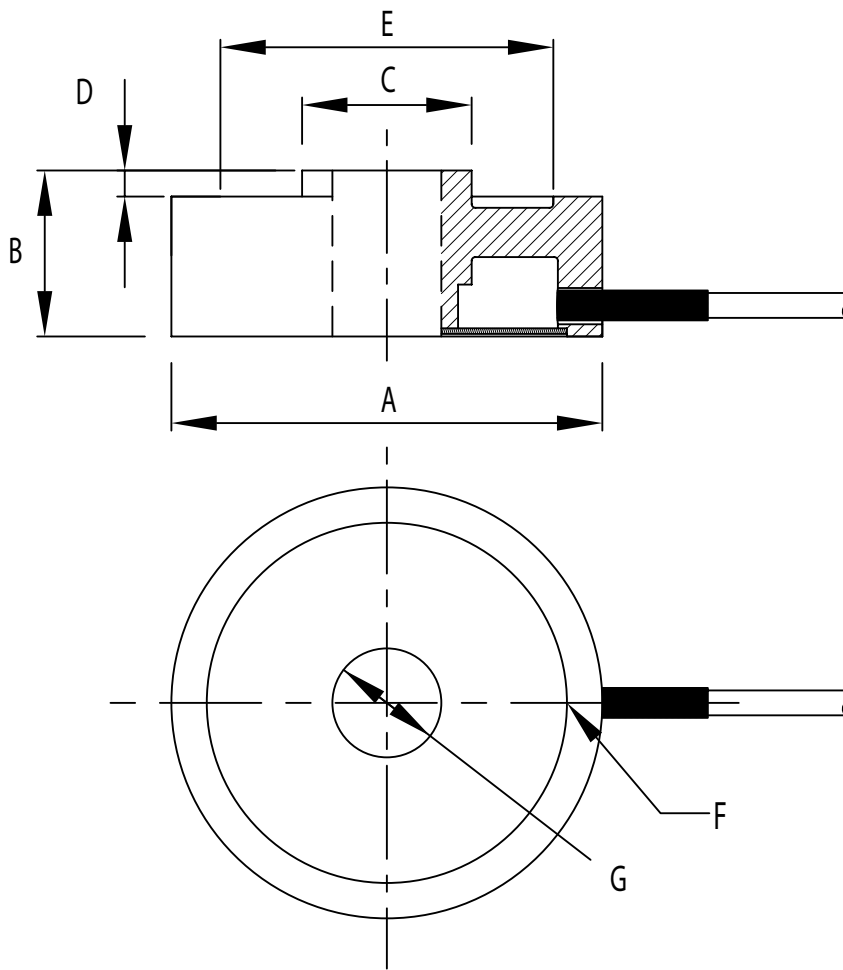

dimension \ capacity	100-2,000lb	3klb	5klb
Outer diameter - A	31.2	50.8	50.8
Load cell Height - B	10.16	16.0	16.0
Flat load button dia. - C	11.9	22.0	22.0
Load pin Height -D	1.78	2.08	2.5
Upper ring. Dia. - E	23.1	40.0	40.0
Bottom ring. Dia. - F	25.4	43.0	43.0
Hole dia. - G	4.9	13.0	13.0

Specifications and dimensions are subject to change without notice.

product dimensions for 100lb - 5klb models (mm)

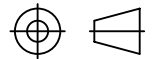
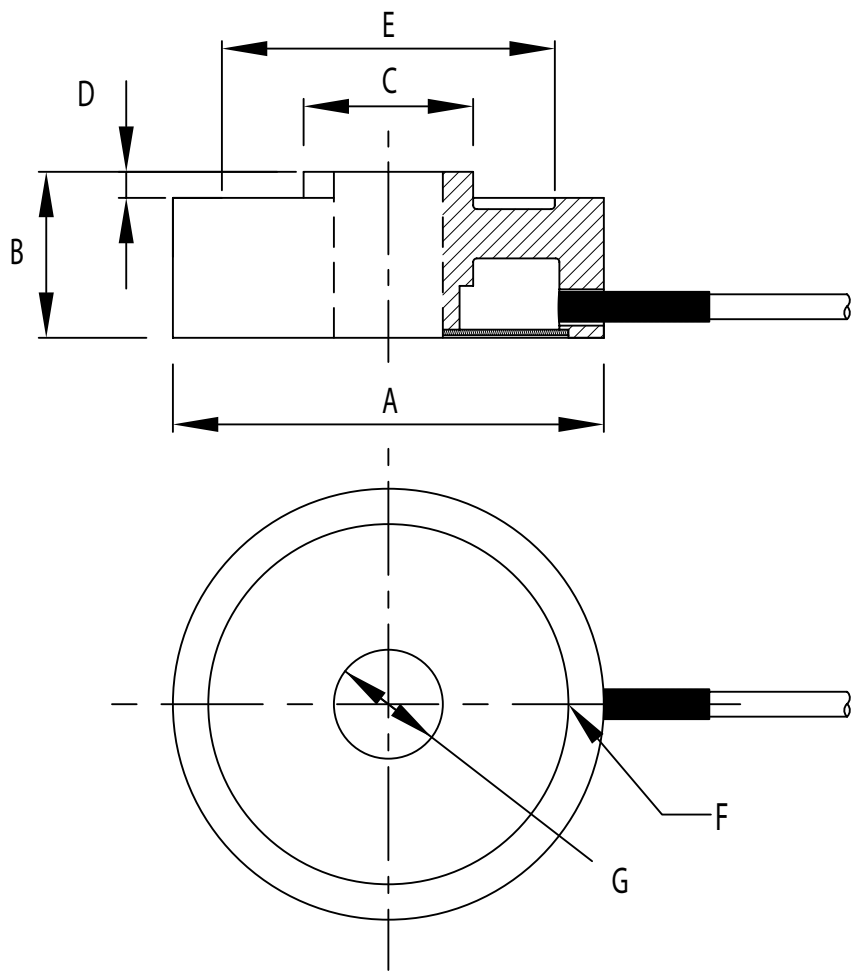

dimension \ capacity	10klb	15/20klb	30klb	50klb
Outer diameter - A	50.8	50.8	50.8	76.2
Load cell Height - B	16.0	25.4	25.4	38.1
Flat load button dia. - C	22.0	22.0	22.0	42.0
Load pin Height -D	2.0	4.0	2.5	3.0
Upper ring. Dia. - E	45.0	40.0	36.04	59.6
Bottom ring. Dia. - F	43.0	42.6	38.04	61.6
Hole dia. - G	13.0	13.0	13.0	26.0

Specifications and dimensions are subject to change without notice.