

FT-30M radio (DIN) slot kit

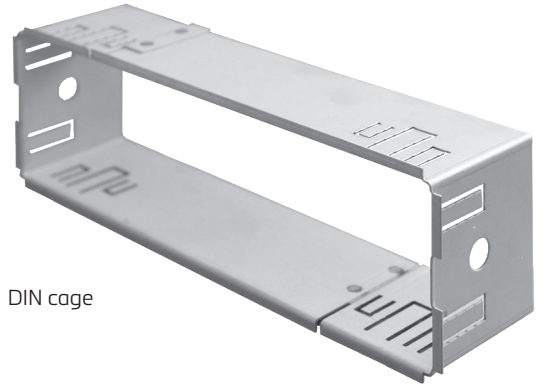

FT-30M with mounting ears



DIN cage



Mounting Ears



M3 Socket head cap screws



Extraction keys

The FT-30M is sized to fit the standard specification of a radio slot. Each radio slot kit comprises two mounting ears, a zinc plated DIN cage, extraction keys and screws.

Installation

In the truck cab, locate a suitable spare DIN radio slot. Remove the existing cover plate. The DIN cage fits snugly into the opening right up to the lip of the DIN cage. Before you push it in, pull the wiring cables through the cage.

Once in place, use a small screwdriver or similar tool to pry down on the securing tabs around the perimeter of the cage so they grip the inside the opening. This will prevent the cage from slipping out or tilting from the weight of the FT-30M.

There is no upside down. The DIN cage is symmetrical, either way, top and bottom, left and right. Some vehicles may already have an 'ISO Mounting', this means the DIN cage is not required, the FT-30M will fit snugly into the opening without the cage.

Connect the power and signal connectors to the back of the FT-30M. Screw the DIN mounting ears to the FT-30M using the M3 socket head cap screws provided.

Push the indicator in to the DIN cage until it snaps into position.

Remove the FT-30M using the two extraction tools, place the keys into the slots located in either ear and press downwards so they grip inside the ears, gently pull on the keys and the indicator pulls out.

Dimensions (mm)

Cage sizes conform to ISO 7736 (Formally DIN 75490).

Cage size: H53mm x W182mm x D45mm

