

**NEU: Erweitertes Adapterprogramm**  
**NEW: Extended adapter program**

Modulares Schnellwechselsystem  
Modular quick change system

**BENZ Solidfix**<sup>®</sup>



# BENZ Solidfix®: Bedienerfreundlich, stabil und höchst präzise

## BENZ Solidfix®: User friendly, rigid and extremely precise

### Rüstzeiten reduzieren!

Mit dem neuen modularen Schnellwechselsystem für angetriebene Werkzeuge und Wechselaggregate.

### Reduce setup time!

With the new modular quick change system for live tools and angle heads.

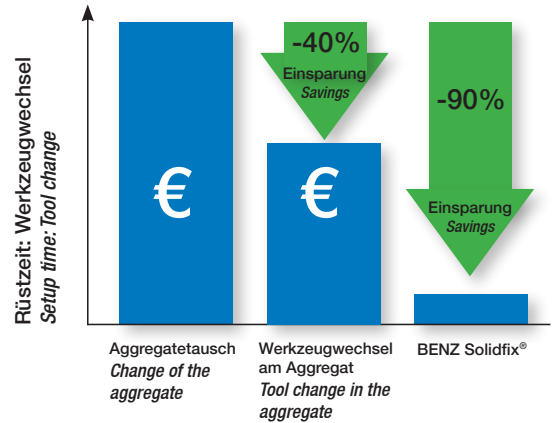

### Systemaufbau

#### System design

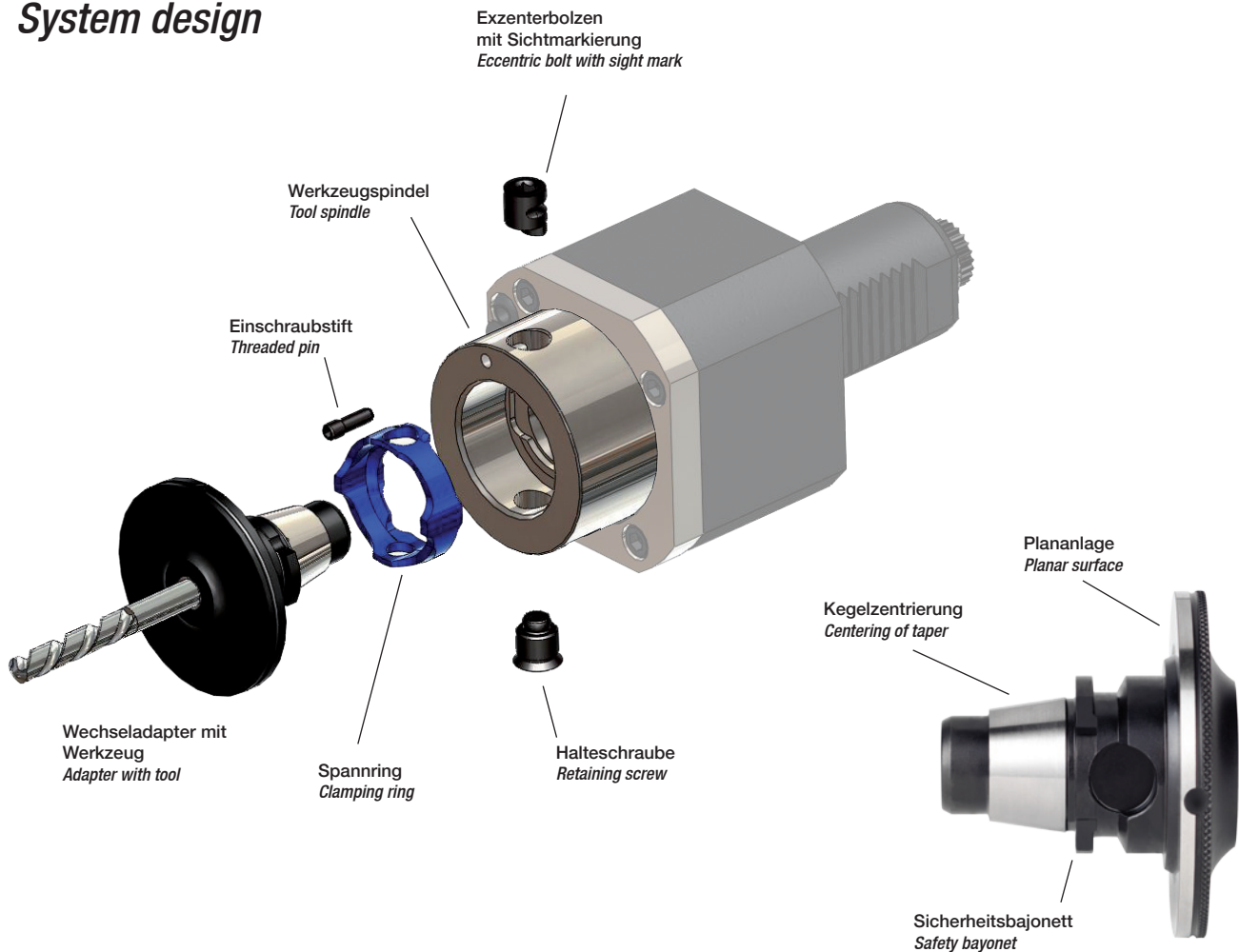

# Adapterübersicht

## Adapter overview

### Werkzeugadapter

#### Tool adapter

Spannzangenfutter 8° Typ ER  
Collet chuck 8° type ER



Weldon für Zylinderschäfte DIN 1835 B  
Weldon for parallel shanks DIN 1835 B



Whistle-Notch für Zylinderschäfte DIN 1835 E  
Whistle Notch for parallel shanks DIN 1835 E



Aufsteckfräsdorn  
Milling machine arbor



Spannzangenfutter mit TER- Schrumpfspannzange  
Collet chuck with TER Shrinking collet



Schrumpffutter  
Shrink fit chuck



Prüfdorn  
Test arbor



Rohling  
Blank



Verschlussstopfen  
Closing plug



### Zerspanungsaggregate

#### Cutting aggregates



Angetriebene Werkzeuge  
Live tools

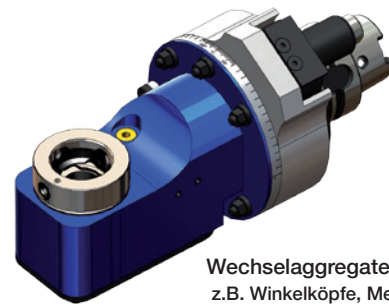

Wechselaggregate  
z.B. Winkelköpfe, Mehrspindelbohrköpfe..  
Exchangeable units  
e.g. Angle heads, multi spindle heads..

### Voreinstelladapter

#### Master shanks



VDI DIN 69880



HSK Form A  
ISO 12164

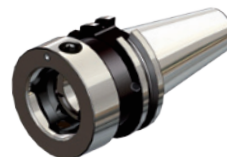

SK DIN 69871  
AD

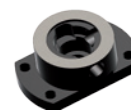

Montageblock  
Assembly block



Reduzierhülse  
Reducing sleeve

...am Ende entscheiden die besten Trümpfe!

## Leistung

- Kompakte Bauform
- Große Plananlage
- Hohe Systemsteifigkeit  $\Rightarrow$  fräsggeeignet
- Hohe Drehmomentübertragung
- Hohe Drehzahlen (wuchtneutraler Aufbau)



## Performance

- *Compact design*
- *Large planar contact surface*
- *High rigidity  $\Rightarrow$  milling capable*
- *High transmission of torque*
- *High speed (balancing-neutral design)*



## Präzision

- Sehr hohe Rundlaufgenauigkeit:  $< 5 \mu\text{m}$  auf 30 mm
- Hohe Wiederholgenauigkeit
- Zentrale, querkraftfreie Krafteinleitung
- Spielfreie Kegelzentrierung



## Precision

- *High concentricity:  $< 5 \mu\text{m}$  on 30 mm*
- *High repeatability*
- *Central, cross-force-free transmission of forces*
- *Play-free centering of taper*

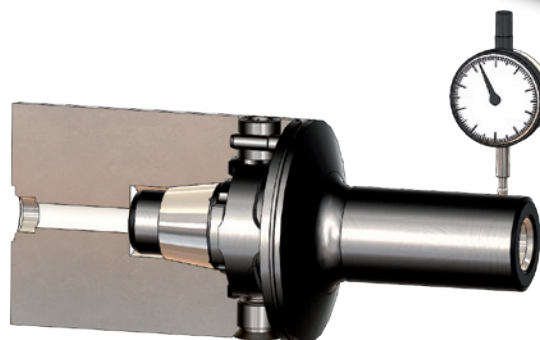

*...only the one with all four aces is guaranteed to win!*

## Handhabung

- Quick Change, Wechselzeit < 20 Sekunden
- Einhandbedienung
- Einfaches Handling ohne Spezialwerkzeug
- Weggesteuertes Spannen (180°) – Anziehen ohne Drehmomentschlüssel möglich
- Automatische Ausstoßfunktion



## Handling

- *Quick-change, change in < 20 seconds*
- *One-hand operation*
- *Simple handling without the need of special tools*
- *Resistance controlled clamping (180°) - no need to observe torque*
- *Ejection feature*



## Sicherheit

- Verliersicherung über Sicherheitsbajonett
- Selbstsichernde Spannfunktion
- Vermeidung von Fehlbedienung
- Erfüllt Maschinenrichtlinie nach 2006/42/EG



## Safety

- *Securing device via safety bayonet*
- *Self-locking clamp function*
- *Avoidance of operating errors*
- *Fullfills machinery directive 2006/42/EG*



Größe Size	T [Nm]	Größe Spannschlüssel Wrench size	Empfohlene VDI Größe Recommended VDI size	Adapter Spannanzage Adapter collet chuck	Max. Spanndurchmesser Max. clamping diameter Weldon/Whistle-Notch
S1	25	SW 3	VDI 20	ER 16	10
S2	50	SW 4	VDI 25	ER 20	12
S3	100	SW 5	VDI 30	ER 25	16
S4	200	SW 6	VDI 40	ER 32	20
S5	400	SW 6	VDI 50	ER 40	25



### Einsatz Drehtechnik: Angetriebene und Statische Werkzeuge

#### Application turning technology: Live tools and static tools

Für alle gängigen Drehmaschinen  
Siehe Katalog: Werkzeugsysteme für CNC-Drehmaschinen: [www.benz-tools.de](http://www.benz-tools.de)

For all established CNC-lathes  
Catalog: Tool systems for CNC-lathes, [www.benz-tools.de](http://www.benz-tools.de)

Baruffaldi Revolver	Gildemeister* <b>Trifix</b> ®	Mazak*	Schaublin
Boehringler	Graziano	Miyano	Spinner
Daewoo*	Haas*	Monforts	<b>TAKAMAZ*</b>
Doosan*	Hessapp	<b>MORI SEIKI*</b>	Traub
Duplomatic*	Hurco	<b>Nakamura*</b>	WEISSER
EMAG*	INDEX	<b>OKUMA*</b>	
EMCO	Laru Revolver	<b>Sauter Revolver*</b>	



\*Kernlieferprogramm | Core product range      Weitere Hersteller auf Anfrage | Additional manufacturers on request

**Trifix**®-Präzisionsschnittstelle: BENZ, lizenzierter Systempartner von DMG; siehe Seite 15  
**Trifix**® precision interface: BENZ, licensed partner of DMG; see page 15

### Einsatz Bearbeitungszentren: Winkelköpfe und Mehrspindelbohrköpfe

#### Application machining centers: Angle heads and multi spindle heads

Für alle gängigen Bearbeitungszentren  
Katalog: Werkzeugsysteme für Bearbeitungszentren: [www.benz-tools.de](http://www.benz-tools.de)

For all established machining centers  
Catalog: Tool systems for machining centers, [www.benz-tools.de](http://www.benz-tools.de)

Burkhardt + Weber	HELLER	StarragHeckert
CHIRON	Hermle	SW
DMG	Hurco	WFL
Haas	Matec	

Weitere Hersteller auf Anfrage | Additional manufacturers on request



## Spannzangenfutter 8° Typ ER | Collet chuck 8° type ER

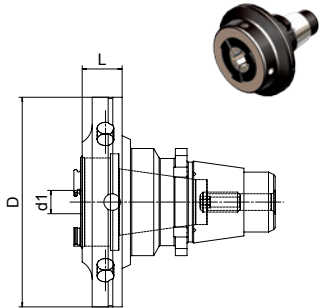

Spannzangenfutter 8° Typ ER | Collet chuck 8° type ER

Größe Size	Typ Type	D	d1	d2	L	Bestell-Nr. Order No.
S1	ER 11	32	1-7	-	9	691.130E1A09
S2	ER 16	40	1-10	-	13	692.130E3A13
S3	ER 16	50	1-10	-	10	693.130E3A10
S3	ER 20	50	2-13	-	14	693.130E4A14
S4	ER 20	63	2-13	-	12	694.130E4A12
S4	ER 25	63	2-16	-	20	694.130E5A20
S5	ER 32	75	2-20	-	22	695.130E6A22

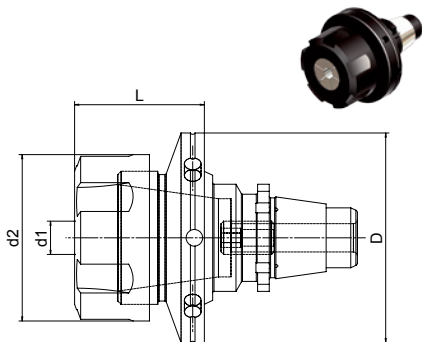

Spannzangenfutter 8° Typ ER | Collet chuck 8° type ER

Größe Size	Typ Type	D	d1	d2	L	Bestell-Nr. Order No.
S1	ER 11M	32	1-7	16	20	691.130M120
S1	ER 16M	32	1-10	22	30	691.130M230
S2	ER 20M	40	2-13	28	31	692.130M331
S2	ER 20	40	2-13	34	31	692.130E431
S3	ER 25	50	2-16	42	34	693.130E534
S4	ER 32	63	2-20	50	39	694.130E639
S5	ER 40	75	3-26	63	46	695.130E746

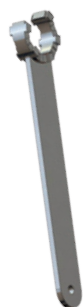

Spannschlüssel für innenliegende Spannmutter  
Clamping wrench for inside clamping nut D+E

ER	Bestell-Nr. Order No.
11	B136-E1AX
16	B136-E3AX
20	B136-E4AX
25	B136-E5AX
32	B136-E6AX



Spannschlüssel für außenliegende Spannmutter  
Clamping wrench for external clamping nut

ER	Bestell-Nr. Order No.
11M	B136-M1
16M	B136-M2
20M	B136-M3
20	B136-E4
25	B136-E5
32	B136-E6
40	B136-E7

### Weldon für Zylinderschäfte DIN 1835 B | Weldon for parallel shanks DIN 1835 B

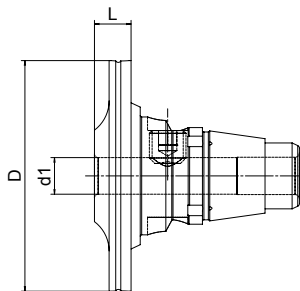

#### Weldon DIN 1835 B: Kurze Ausführung | Short design

Größe Size	D	d1	d2	L	Bestell-Nr. Order No.
S1	32	3	-	4	691.1400304
S1	32	4	-	5	691.1400405
S2	40	4	-	5	692.1400405
S2	40	6	-	7	692.1400607
S3	50	6	-	6	693.1400606
S3	50	8	-	8	693.1400808
S4	63	6	-	7	694.1400607
S4	63	8	-	8	694.1400808
S4	63	10	-	10	694.1401010
S4	63	12	-	12	694.1401212
S5	75	6	-	10	695.1400610
S5	75	8	-	10	695.1400810
S5	75	10	-	10	695.1401010
S5	75	12	-	10	695.1401210
S5	75	16	-	12	695.1401612

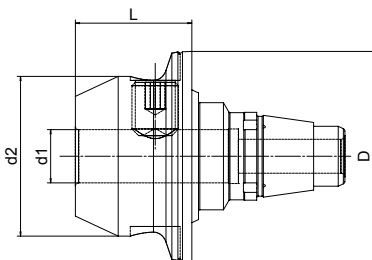

#### Weldon DIN 1835 B: Standard Ausführung | Standard design

Größe Size	D	d1	d2	L	Bestell-Nr. Order No.
S1	32	6	25	24	691.1400624
S2	40	8	28	25	692.1400825
S3	50	10	35	28	693.1401028
S3	50	12	42	32	693.1401232
S3	50	16	48	35	693.1401635
S4	63	14	48	32	694.1401432
S4	63	16	48	35	694.1401635
S4	63	20	52	38	694.1402038
S5	75	20	52	38	695.1402038
S5	75	25	65	40	695.1402540



Whistle Notch für Zylinderschäfte DIN 1835 E | Whistle Notch for parallel shanks DIN 1835 E

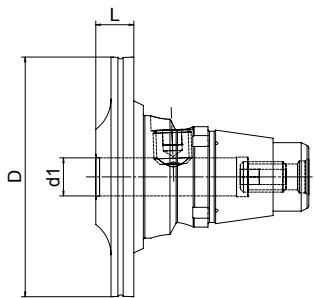

Whistle Notch DIN 1835 E: Kurze Ausführung | Short design

Größe Size	D	d1	d2	L	Bestell-Nr. Order No.
S2	40	6	-	9	692.1410609
S3	50	6	-	6	693.1410606
S3	50	8	-	8	693.1410808
S4	63	6	-	7	694.1410607
S4	63	8	-	8	694.1410808
S4	63	10	-	10	694.1411010
S4	63	12	-	12	694.1411212
S5	75	6	-	10	695.1410610
S5	75	8	-	10	695.1410810
S5	75	10	-	10	695.1411010
S5	75	12	-	10	695.1411210
S5	75	16	-	12	695.1411612

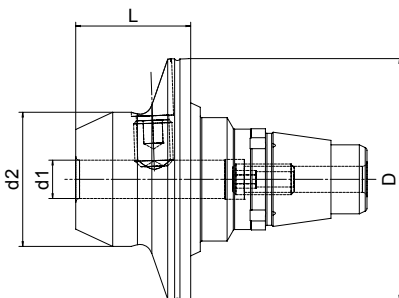

Whistle Notch DIN 1835 E: Standard Ausführung | Standard design

Größe Size	D	d1	d2	L	Bestell-Nr. Order No.
S1	32	6	25	24	691.1410624
S2	40	8	28	25	692.1410825
S3	50	10	35	28	693.1411028
S3	50	12	42	32	693.1411232
S3	50	16	48	35	693.1411635
S4	63	14	48	32	694.1411432
S4	63	16	48	35	694.1411635
S4	63	20	52	38	694.1412038
S5	75	20	52	38	695.1412038
S5	75	25	65	40	695.1412540

### Aufsteckfräsdorn | Milling machine arbor

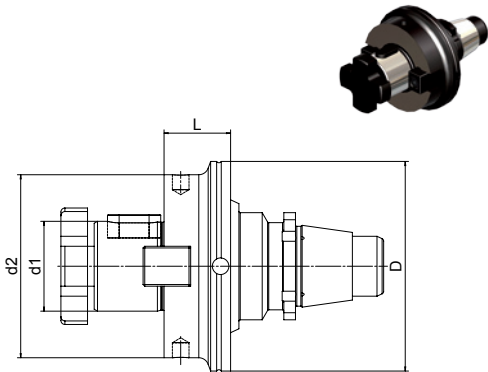

### Aufsteckfräsdorn | Milling machine arbor

Größe Size	D	d1	d2	L	Bestell-Nr. Order No.
S2	40	16	34	11	692.2311611
S3	50	16	34	12	693.2311612
S3	50	22	48	14	693.2312214
S4	63	22	48	14	694.2312214
S4	63	27	55	14	694.2312714
S5	75	22	48	12	695.2312212
S5	75	27	55	14	695.2312714
S5	75	32	62	15	695.2313215

Hinweis: Schlüssel und Mitnahmesteine verfügbar  
 Note: wrenches and keys available

### Spannzangenfutter mit TER- Schrumpfspannzange | Collet chuck with TER- Shrinking collet

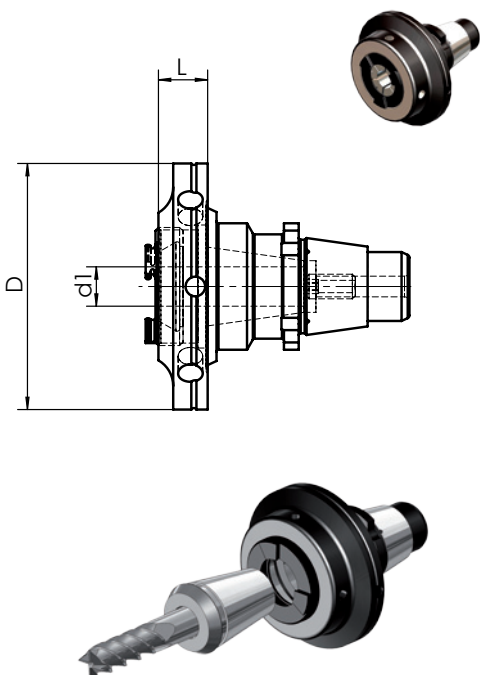

### Schrumpfen mit TER- Spannzange | Shrinking with TER- collet chuck

Größe Size	Typ Type	D	d1	L	Bestell-Nr. Order No.
S1	TER 16	32	3	30*	691.1560330
S1	TER 16	32	4	30*	691.1560430
S1	TER 16	32	6	30*	691.1560630
S2	TER 16	40	3	13	692.1560313
S2	TER 16	40	4	13	692.1560413
S2	TER 16	40	6	13	692.1560613
S2	TER 16	40	8	13	692.1560813
S3	TER 20	50	6	14	693.1560614
S3	TER 20	50	8	14	693.1560814
S3	TER 20	50	10	14	693.1561014
S4	TER 25	63	6	20	694.1560620
S4	TER 25	63	8	20	694.1560820
S4	TER 25	63	10	20	694.1561020
S4	TER 25	63	12	20	694.1561220
S5	TER 32	75	6	22	695.1560622
S5	TER 32	75	8	22	695.1560822
S5	TER 32	75	10	22	695.1561022
S5	TER 32	75	12	22	695.1561222
S5	TER 32	75	16	22	695.1561622

Lieferumfang:  
 Spannzangenadapter + TER- Schrumpfspannzange

Scope of delivery:  
 Collet chuck adapter + TER- collet chuck

\* Größe S1: Verwendung eines Spannzangen- Adapter mit aussenliegender Mininutter  
 Size S1: Utilization of a collet chuck with external mini nut

### TER- Zubehör | TER- Accessories

TER Schrumpfspannzange |  
TER Shrinking collet

Größe Size	Typ Type	d1	Bestell-Nr. Order No.
S1/ S2	TER 16	3	B134-426E-0300DS
S1/ S2	TER 16	4	B134-426E-0400DS
S1/ S2	TER 16	6	B134-426E-0600DS
S2	TER 16	8	B134-426E-0800DS
S3	TER 20	6	B134-428E-0600DS
S3	TER 20	8	B134-428E-0800DS
S3	TER 20	10	B134-428E-1000DS
S4	TER 25	6	B134-430E-0600DS
S4	TER 25	8	B134-430E-0800DS
S4	TER 25	10	B134-430E-1000DS
S4	TER 25	12	B134-430E-1200DS
S5	TER 32	6	B134-470E-0600DS
S5	TER 32	8	B134-470E-0800DS
S5	TER 32	10	B134-470E-1000DS
S5	TER 32	12	B134-470E-1200DS
S5	TER 32	16	B134-470E-1600DS

Spannzangenfutter für TER Schrumpfspannzange |  
Collet chuck for TER Shrinking collet

Größe Size	Typ Type	D	d1	L	Bestell-Nr. Order No.
S1	ER 16M	32	1-10	30	691.130M230UP
S2	ER 16	40	1-10	13	692.130E3A13UP
S3	ER 20	50	2-13	14	693.130E4A14UP
S4	ER 25	63	2-16	20	694.130E5A20UP
S5	ER 32	75	2-20	22	695.130E6A22UP

Einsatz, Grundadapter | Insert, Adapter

Größe Size	Typ Type	Bestell-Nr. Order No.
S1 / S2	Einsatz / Insert TER 16	B136-426E-DSE
S3	Einsatz/ Insert TER 20	B136-428E-DSE
S4	Einsatz/ Insert TER 25	B136-430E-DSE
S5	Einsatz/ Insert TER 32	B136-470E-DSE
S1 - S5	Grundadapter mit Längenanschlag Adapter with length adjustment	B136-4XXE-DSG



Sofern Sie weiteres Zubehör wie Diebold- Schrumpfgeräte mit fest hinterlegten Parametern zum Schrumpfen der TER-Spannzangen, den Flüssigkeitskühler FKS 03 oder Adapterringe benötigen, zögern Sie nicht, uns zu kontaktieren.  
*If you need further accessories like Diebold- shrinking devices with stored parameters for shrinking of the TER- collet chucks, the fluid cooler FSK03 or apadapter rings please do not hesitate to contact us.*

### Schrumpffutter | Shrink fit chuck

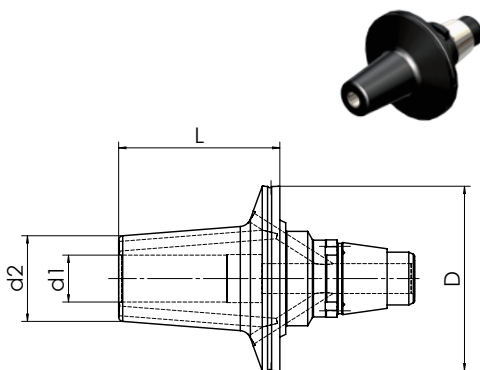

Schrumpffutter | Shrink fit chuck

Größe Size	D	d1	d2	L	Bestell-Nr. Order No.
S3	50	6	21	45	693.1520645KB
S3	50	8	21	45	693.1520845KB
S3	50	10	24	50	693.1521050KB
S3	50	12	24	55	693.1521255KB
S4	63	6	21	50	694.1520650KB
S4	63	8	21	50	694.1520850KB
S4	63	10	24	50	694.1521050KB
S4	63	12	24	55	694.1521255KB
S4	63	14	29	55	694.1521455KB
S4	63	16	29	55	694.1521655KB
S4	63	20	33	60	694.1522060KB
S5	75	20	33	65	695.1522065KB
S5	75	25	44	70	695.1522570KB

KB = Kühlmittelbohrung | coolant holes  
ohne Kühlmittelbohrung auf Nachfrage | without coolant holes on request

### Prüfdorn | Test arbor

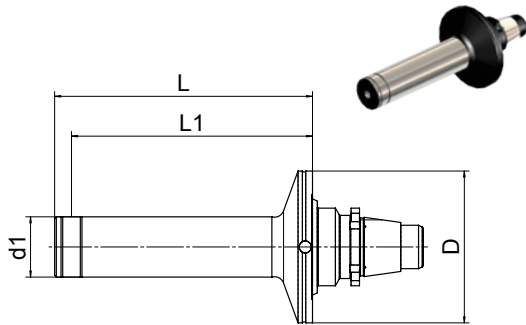

### Prüfdorn | Test arbor

Größe Size	D	d1	L	L1	Bestell-Nr. Order No.
S1	32	12	55	50	691.2471255
S2	40	16	68	63	692.2471668
S3	50	20	87	80	693.2472087
S4	63	25	107	100	694.24725107
S5	75	32	134	125	695.24732134

### Voreinstelladapter | Master shank

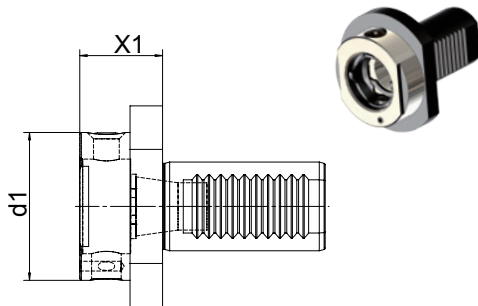

### VDI- Voreinstelladapter | VDI- Master shank

VDI	Größe Size	d1	X1	Bestell-Nr. Order No.
VDI 20	S1	32	22	112.251S1022VE
VDI 25	S2	40	25	325.251S2025VE
VDI 30	S2	40	25	113.251S2025VE
VDI 30	S3	50	28	113.251S3028VE
VDI 40	S3	50	28	114.251S3028VE
VDI 40	S4	63	30	114.251S4030VE
VDI 50	S5	75	32	115.251S5032VE

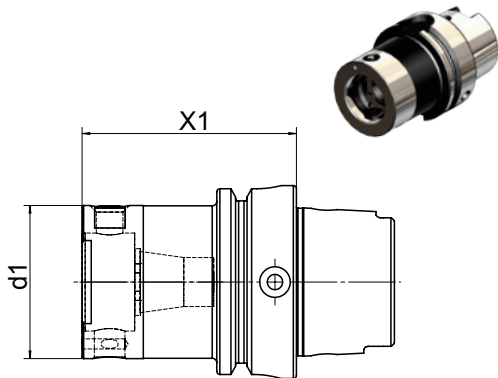

### HSK- Voreinstelladapter | HSK- Master shank

HSK	Größe Size	d1	X1	Bestell-Nr. Order No.
HSK 63	S1	32	55	711.251S1055VE
HSK 63	S2	40	62	711.251S2062VE
HSK 63	S3	50	70	711.251S3070VE
HSK 63	S4	63	75	711.251S4075VE
HSK 63	S5	75	80	711.251S5080VE
HSK 100	S4	63	80	713.251S4080VE
HSK 100	S5	75	90	713.251S5090VE

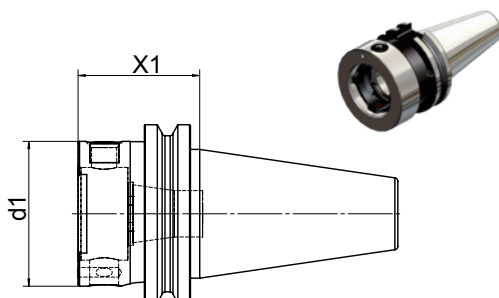

### SK- Voreinstelladapter | SK-Master shank

SK	Größe Size	d1	X1	Bestell-Nr. Order No.
SK 30	S2	40	40	090.251S2040VE
SK 40	S3	50	42	040.251S3042VE
SK 40	S4	63	55	040.251S4055VE
SK 50	S5	75	52	042.251S5052VE

### Montageblock | Assembly block

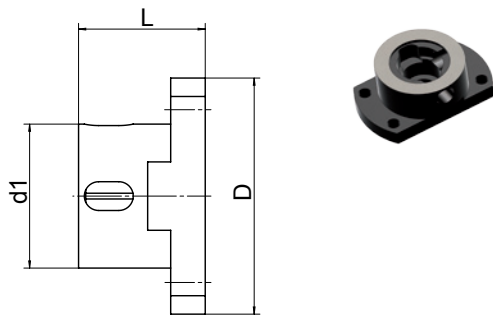

#### Montageblock | Assembly block

Größe Size	D	d1	L	Bestell-Nr. Order No.
S1	62	31	30	B300-4-S1
S2	67	40	38	B300-4-S2
S3	82	50	44	B300-4-S3
S4	96	65	50	B300-4-S4
S5	116	75	60	B300-4-S5

### Reduzierhülse | Reducing sleeve

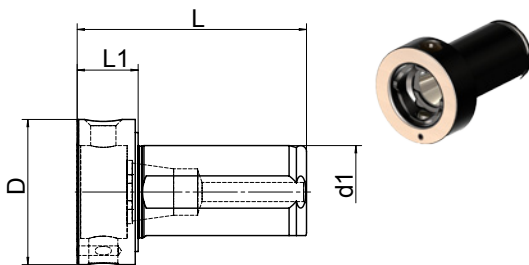

#### Reduzierhülse | Reducing sleeve

Größe Size	D	d1	L	L1	Bestell-Nr. Order No.
S2	40	25	65	17	B570-25S2
S3	50	32	79	21	B570-32S3
S4	63	40	94	22	B570-40S4

### Hartrohling | Bar blank

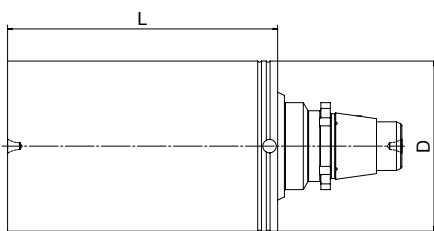

#### Rohling | Blank

Größe Size	D	L	Bestell-Nr. Order No.
S1	32	63	691.1023263
S2	40	80	692.1024080
S3	50	100	693.10250100
S4	63	125	694.10263125
S5	75	160	695.10275160

### Verschlussstopfen | Closing plug

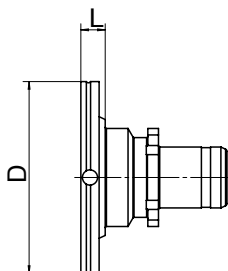

#### Verschlussstopfen | Closing plug

Größe Size	D	L	Bestell-Nr. Order No.
S1	32	3,5	691.581S
S2	40	4	692.581S
S3	50	5	693.581S
S4	63	6	694.581S
S5	75	8	695.581S



**Aufgabenstellung:**  
anspruchsvolle Fräsbearbeitung  
bei beengten Platzverhältnissen

**Maschine:** EMAG VL5  
**Kunde:** INA Schaeffler

**Task:**  
Challenging milling operation within  
confined spaces

**Machine:** EMAG VL5  
**Client:** INA Schaeffler

### Deutliche Reduzierung der Rüstzeiten:

Die Basiseinheiten der angetriebenen Werkzeuge bleiben permanent auf dem Revolver eingespannt, wodurch aufwändiges Feineinrichten der schweren und teilweise schlecht zugänglichen angetriebenen Werkzeuge entfällt.

#### Schritt 1

Parallel zum Zerspanungsprozess kann das Schneidwerkzeug im Werkzeugadapter voreingestellt werden. Dies ermöglicht einen schnellen Werkzeugwechsel und eine erhebliche Reduzierung der Stillstandzeit, da der Werkzeugadapter einsatzbereit an der Maschine zur Verfügung steht.

#### Schritt 2

Unter Verwendung eines Sechskant-Schlüssels kann der zu wechselnde Adapter von der Spindel gelöst werden. Hierbei wird die Abhebefunktion betätigt und der Adapter mit Schneidwerkzeug kann nach einer zusätzlichen Drehbewegung aus der Spindelaufnahme entnommen werden.

#### Schritt 3

Nach einer kurzen Reinigung kann der neue, voreingestellte Werkzeugadapter eingesetzt werden. Durch eine einfache Drehung der Spannschraube um 180°, (bis auf Festanschlag – keine Drehmomentangaben zu berücksichtigen) ist der neue Werkzeugadapter fixiert. Der Werkzeugwechsel kann in weniger als 20 Sekunden durchgeführt werden und bietet ideale Voraussetzungen für effizientes Arbeiten.

### Significant reduction in set-up time:

*The base holder of the live tools remain permanently clamped on the revolver, which makes complicated fine adjustment of the heavy and sometimes hard to access live tools redundant.*

#### Step 1

*Parallel to the manufacturing process the tool adapter can be preset. This enables a quick tool change while preset cutting tools can be at the ready on the machine.*

#### Step 2

*With the use of a hex wrench the adapter that needs to be changed can be loosened from the spindle. To do this, the self-clamping device is opened and the adapter with the cutting tool can – after an additional turn – be removed from the spindle.*

#### Step 3

*After a short cleaning the new, preset tool adapter can be inserted. By simply turning the clamping screw by 180 degree (simply up to locking, no torque has to be considered) the new tooling adapter is fixed. The tool change can be performed in less than 20 seconds and offers ideal conditions for efficient production.*

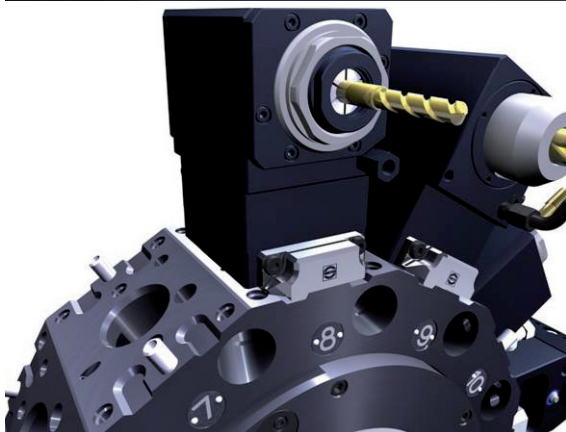
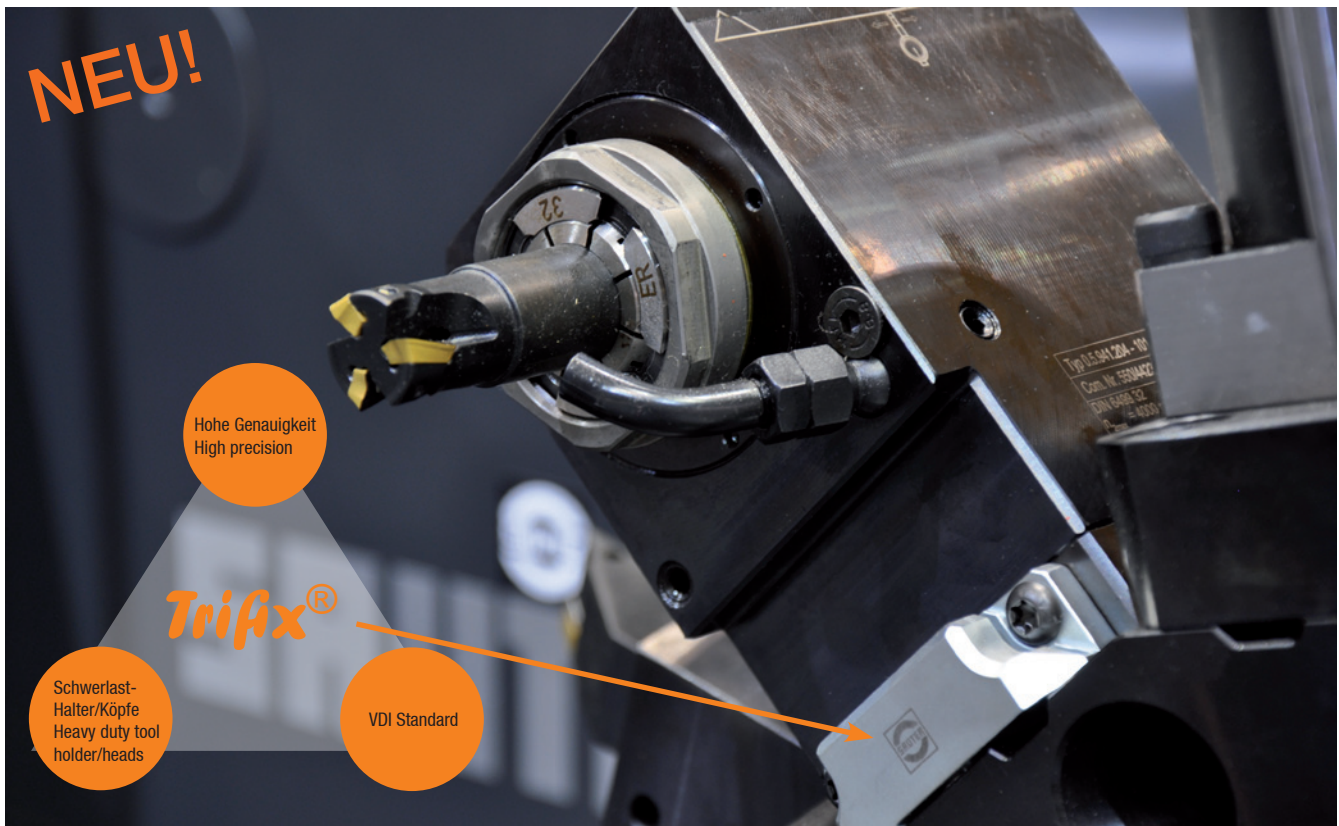

Nur für Gildemeister **Trifix®** Revolver | Only for Gildemeister **Trifix®** turret

**GILDEMEISTER**

**BENZ, lizenziertes Systempartner von DMG**

- Hohe Positioniergenauigkeit ohne Ausrichtaufwand
- Stabile Anbindung durch eine zusätzliche Ausrichtleiste
- Für Schwerzerspannung sehr gut geeignet
- Vorausgerichtet auf jedem Revolverplatz sofort einsetzbar
- Ausführungen auf Anfrage

**BENZ, licensed system partner of DMG**

- *High positioning accuracy without alignment effort*
- *Rigid connection ensured by additional alignment rail*
- *Excellently applicable for heavy duty machining*
- *Preset units can be used immediately at any turret place*
- *Additional designs on request*

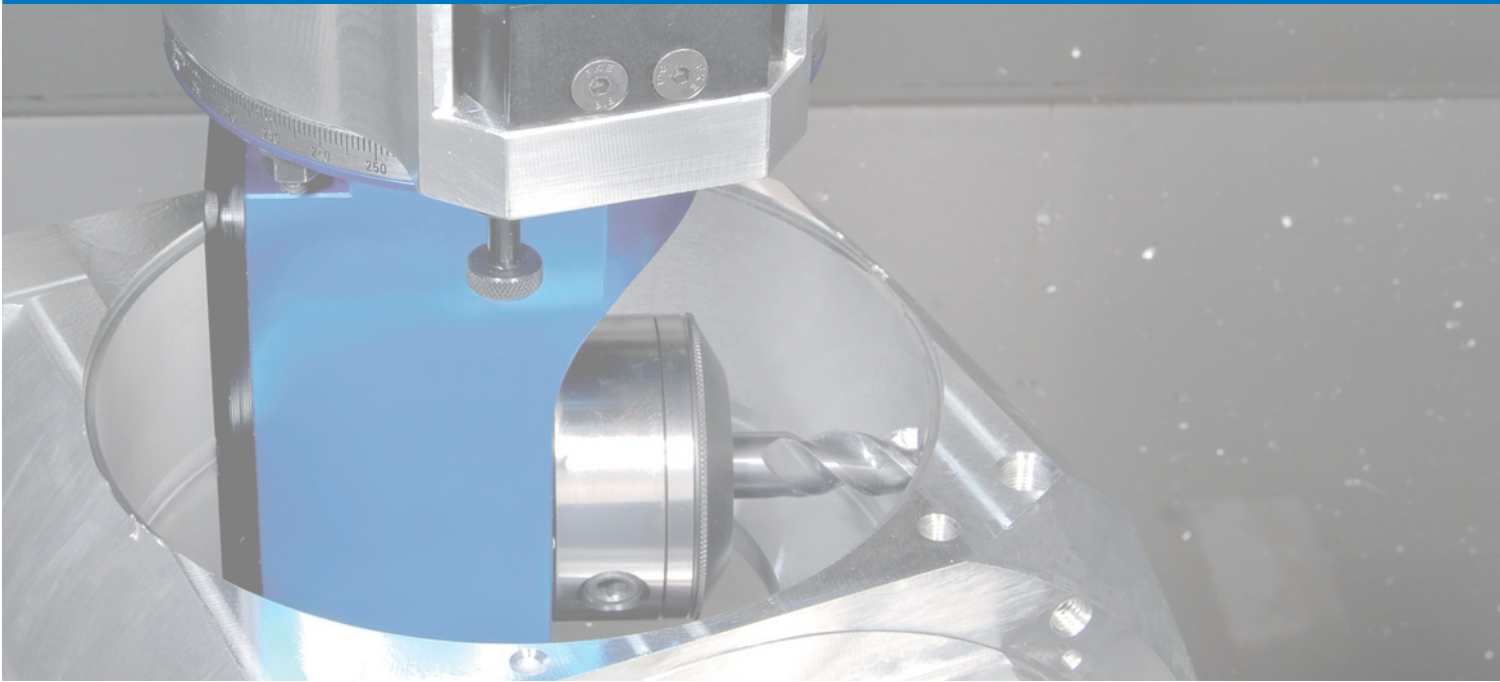

[www.benz-solidfix.de](http://www.benz-solidfix.de)

**BENZ GmbH Werkzeugsysteme**  
Im Mühlegrün 12  
77716 Haslach  
Deutschland | Germany  
Fon +49.7832.704 - 8400  
Fax +49.7832.704 - 21  
[www.benz-tools.de](http://www.benz-tools.de)  
[metal@benz-tools.de](mailto:metal@benz-tools.de)

EIN UNTERNEHMEN DER | MEMBER OF

**ZIMMER**  
G R O U P 

