



orbital

loomma



inspiration



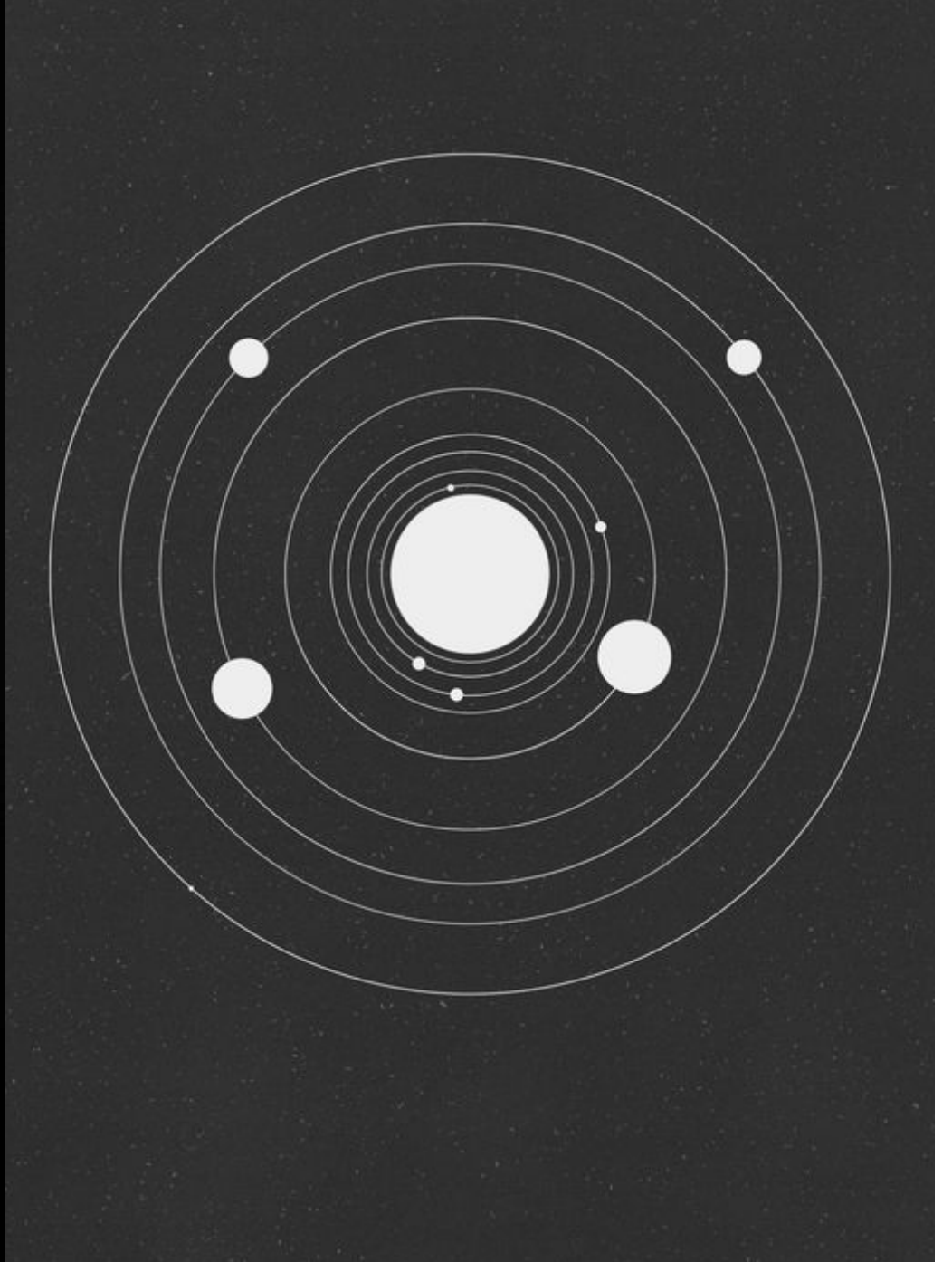



The SOLAR SYSTEM with the Orbits of 5 remarkable COMETS.

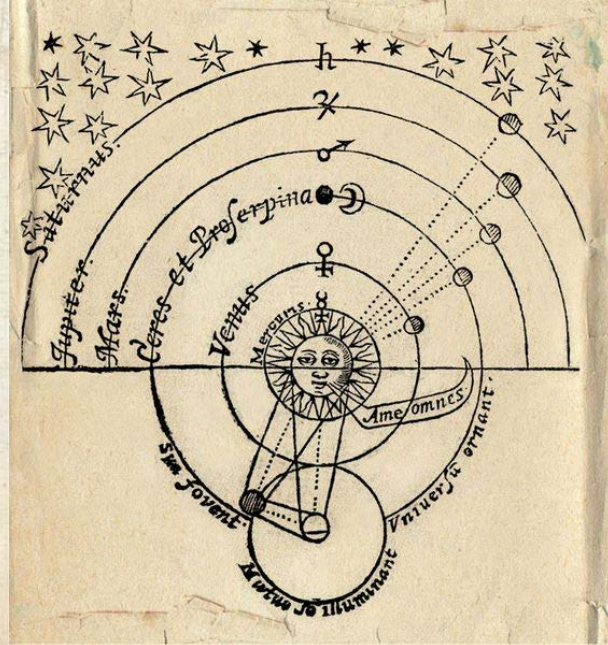
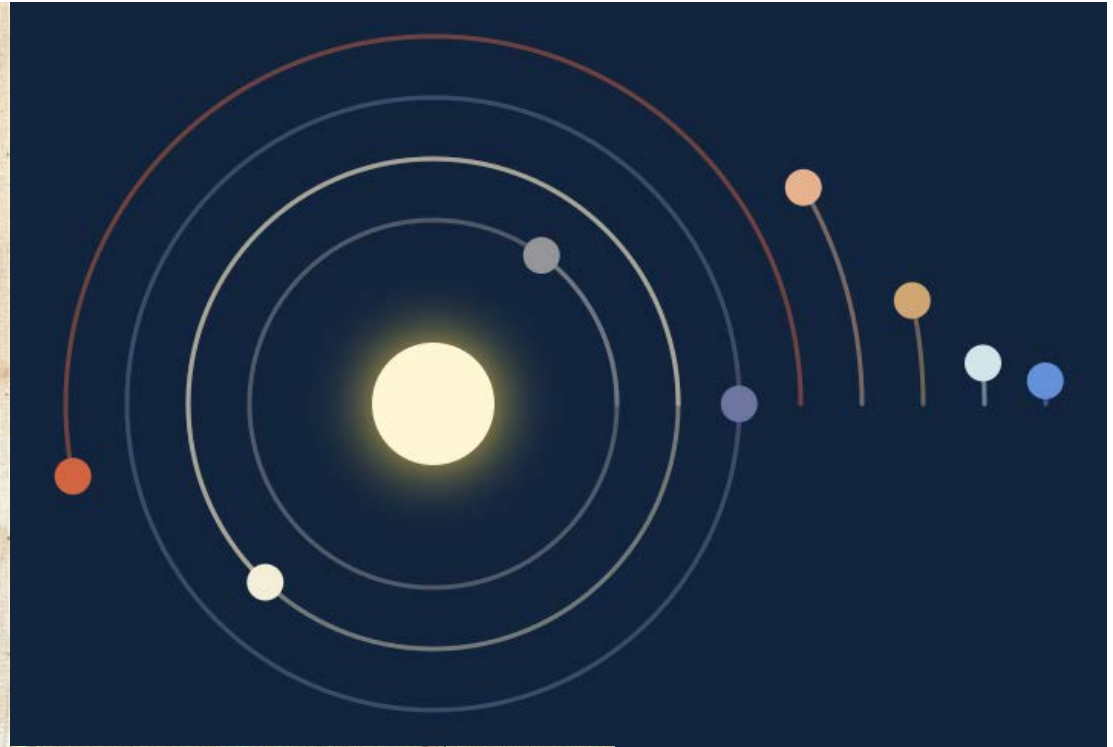
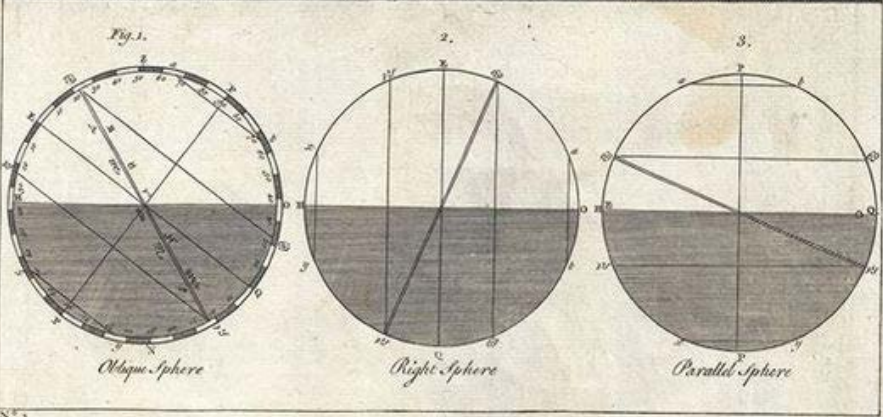
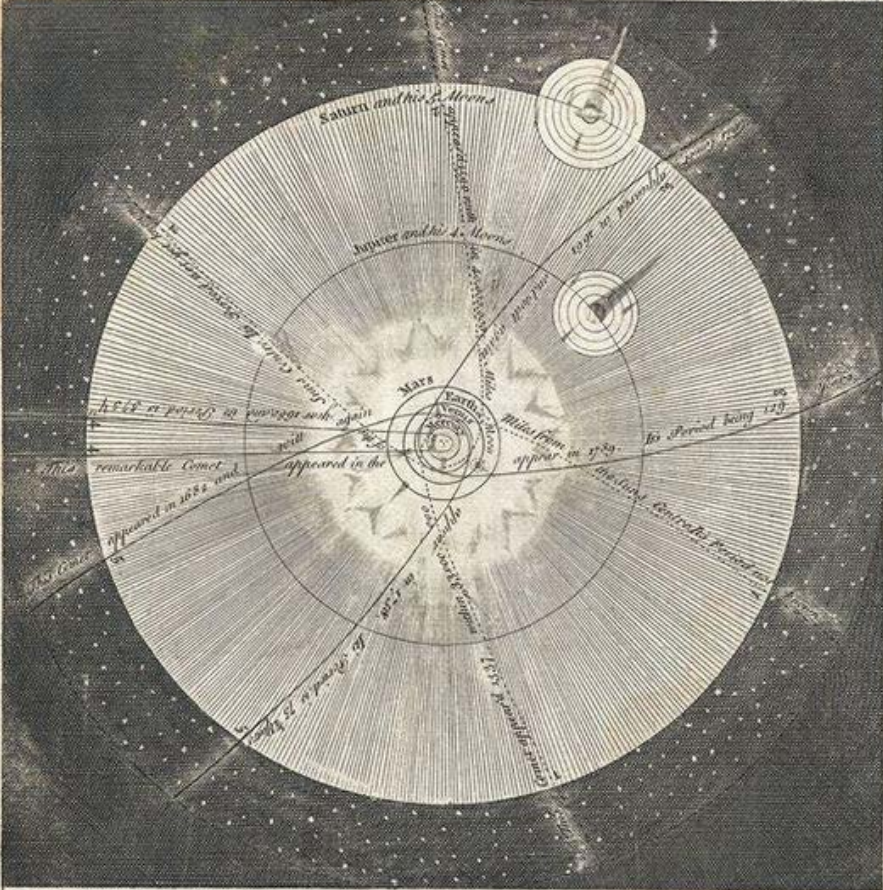

ORBITAL  
Crossing galactic paths.

Orbital paths of multicolored celestial bodies with hypnotically glowing cores. This ingenious design of hand-blown glass lenses, held together by a metal mounting, creates a fascinating visual experience from different angles.

Design by Studio deFORM

production









projects



BOMMA catalogue, 2021



BOMMA Atelier, Prague, 2021





Comforty, 2019



PalermoUno, 2019





Canape by SOFFA, 2018



Minotti catalogue, 2020



options



polaris white  
patina gold fitting



venus pink  
silver fitting



mercury black  
gold fitting



clear  
patina gold fitting

# pendant

Glass options: polaris white, venus pink,  
mercury black, clear  
Fitting options: gold, silver, patina gold

lomma





polaris white  
patina gold fitting



venus pink  
patina gold fitting



mercury black  
gold fitting



clear  
patina gold fitting

# wall & ceiling

Glass options: polaris white, venus pink,  
mercury black, clear  
Fitting options: gold, silver, patina gold

bomma



polaris white  
patina gold fitting



venus pink  
silver fitting



mercury black  
gold fitting



clear  
patina gold fitting

table

Glass options: polaris white, venus pink,  
mercury black, clear  
Fitting options: gold, silver, patina gold

lomma



polaris white + venus pink  
gold fitting



mercury black + neptune blue  
black fitting

floor

Glass options: polaris white, venus pink,  
mercury black, clear  
Fitting options: gold, silver, patina gold

lomma



technical informations

# ORBITAL pendant

Design by  
Studio deFORM

All Bomma products are hand-made from mouth-blown lead-free crystal. Therefore any small bubbles, non-melts and irregularities in the glass are both proof and a characteristic feature of this traditional craft.

The Orbital Collection is made by underlying colored glass technology. Thanks to the manual process of blowing underlay glass, each piece is an original. Individual products may vary slightly in intensity, hue or even color. This is an accompanying characteristic of the traditional underlay glass technology.

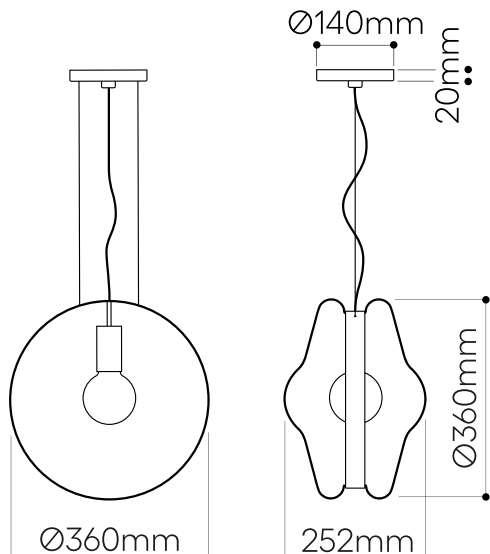

## LIGHTING DESCRIPTION

Size	360 × 254 × 360 mm 14,2 × 10 × 14,2 inch
Cable	black textile braid 2,5 m / 98,4 inch
Weigh	9 kg / 19,8 lb
Material	mouth-blown lead-free crystal with in Moon clear, Venus pink, Polaris white, Neptune blue, Mercury black and Pluto green
Mounting Materials	brushed stainless steel with titan coating / polished stainless steel / polished stainless steel with nitride titan coating / stainless steel with black powder coating
Mounting Colors	patina gold / silver
Protection	IP 20
Nominal voltage	220-230V / A.C. 50 hz (EU) 100-120 V / A.C. 60 Hz (USA)
Class	I. EU / I. USA

## LIGHT SOURCE

Type	G80, 6W LED, 510 lm
Base	E27 EU / E26 USA
Voltage	200-240V, AC / 100-140V, AC
Temperature	2700 K
Color index	RA 90+
Dimming	Dimmable with TRIAC ; on demand dimmable with DALI, RF/WIFI, for information on dimming with other systems please contact your Bomma partner.

## PACKAGING

Material	Cardboard
Size	510 × 430 × 430 mm 20,1 × 16,9 × 16,9 inch

Origin: traditionally produced in the Czech Republic  
Intellectual property license holder: Bomma Czech Republic (EU)  
represented by Bohemia Machine s.r.o.

# ORBITAL table lamp

Design by  
Studio deFORM

All Bomma products are hand-made from mouth-blown lead-free crystal. Therefore any small bubbles, non-melts and irregularities in the glass are both proof and a characteristic feature of this traditional craft.

The Orbital Collection is made by underlying colored glass technology. Thanks to the manual process of blowing underlay glass, each piece is an original. Individual products may vary slightly in intensity, hue or even color. This is an accompanying characteristic of the traditional underlay glass technology.

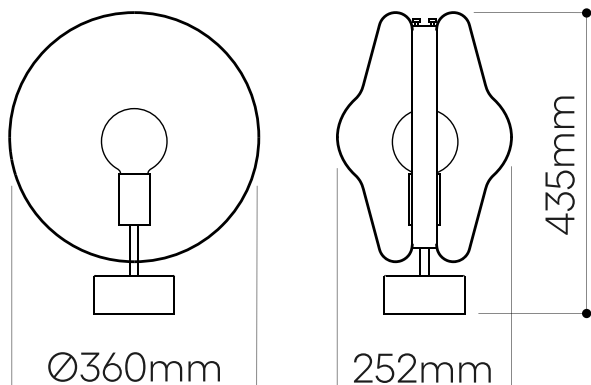

## LIGHTING DESCRIPTION

Size	360 × 435 × 252 mm 14,2 × 17,1 × 9,9 inch
Cable	black textile braid 1,8 m / 70,9 inch
Weigh	12 kg / 26,4 lb
Material	mouth-blown lead-free crystal with in Moon clear, Venus pink, Polaris white, Neptune blue, Mercury black and Pluto green
Mounting Materials	brushed stainless steel with titan coating / polished stainless steel / polished stainless steel with nitride titan coating / stainless steel with black powder coating
Mounting Colors	patina gold / silver
Protection	IP 20
Nominal voltage	220-230V / A.C. 50 hz (EU) 100-120 V / A.C. 60 Hz (USA)
Class	I. EU / I. USA

## LIGHT SOURCE

Type	G80, 6W LED, 510 lm
Base	E27 EU / E26 USA
Voltage	200-240V, AC / 100-140V, AC
Temperature	2700 K
Color index	RA 90+
Dimming	Dimmable with TRIAC ; on demand dimmable with DALI, RF/WIFI, for information on dimming with other systems please contact your Bomma partner. Dimmer within the power cable.

## PACKAGING

Material	Cardboard
Size	510 × 430 × 430 mm 20,1 × 16,9 × 16,9 inch

Origin: traditionally produced in the Czech Republic  
Intellectual property license holder: Bomma Czech Republic (EU)  
represented by Bohemia Machine s.r.o.



# ORBITAL

## wall & ceiling lighting

Design by  
Studio deFORM

All Bomma products are hand-made from mouth-blown lead-free crystal. Therefore any small bubbles, non-melts and irregularities in the glass are both proof and a characteristic feature of this traditional craft.

The Orbital Collection is made by underlying colored glass technology. Thanks to the manual process of blowing underlay glass, each piece is an original. Individual products may vary slightly in intensity, hue or even color. This is an accompanying characteristic of the traditional underlay glass technology.

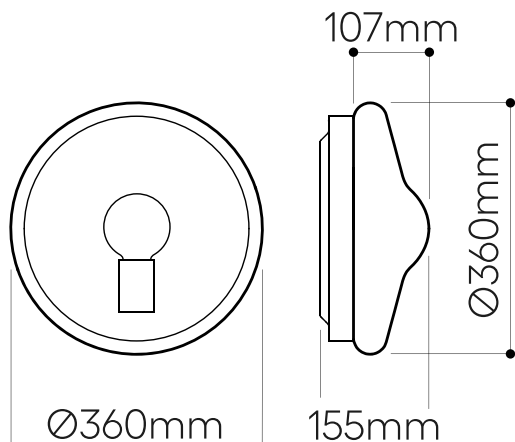

### LIGHTING DESCRIPTION

Size	360 × 155 × 360 mm 14,2 × 6,1 × 14,2 inch
Weight	6,8 kg / 15 lb
Material	mouth-blown lead-free crystal with in Moon clear, Venus pink, Polaris white, Neptune blue, Mercury black and Pluto green
Mounting Materials	brushed stainless steel with titan coating / polished stainless steel / polished stainless steel with nitride titan coating / stainless steel with black powder coating
Mounting Colors	patina gold / silver
Protection	IP 20
Nominal voltage	220-230V / A.C. 50 hz (EU) 100-120 V / A.C. 60 Hz (USA)
Class	I. EU / I. USA

### LIGHT SOURCE

Type	G80, 6W LED, 510 lm
Base	E27 EU / E26 USA
Voltage	200-240V, AC / 100-140V, AC
Temperature	2700 K
Color index	RA 90+
Dimming	Dimmable with TRIAC ; on demand dimmable with DALI, RF/WIFI, for information on dimming with other systems please contact your Bomma partner.

### PACKAGING

Material	Cardboard
Size	510 × 430 × 430 mm 20,1 × 16,9 × 16,9 inch

Origin: traditionally produced in the Czech Republic  
Intellectual property license holder: Bomma Czech Republic (EU)  
represented by Bohemia Machine s.r.o.

# ORBITAL floor lamp

Design by  
Studio deFORM

All Bomma products are hand-made from mouth-blown lead-free crystal. Therefore any small bubbles, non-melts and irregularities in the glass are both proof and a characteristic feature of this traditional craft.

The Orbital Collection is made by underlying colored glass technology. Thanks to the manual process of blowing underlay glass, each piece is an original. Individual products may vary slightly in intensity, hue or even color. This is an accompanying characteristic of the traditional underlay glass technology.

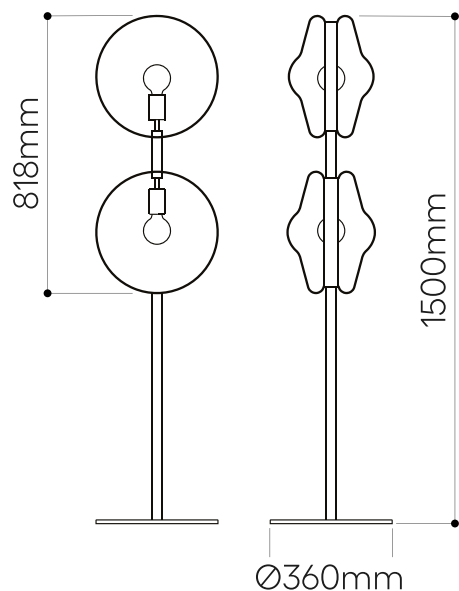

## LIGHTING DESCRIPTION

Size	360 × 1500 mm 14,2 × 59 inch
Cable	black, textile braid 3 m / 118,1 inch
Weight	35 kg / 77 lb
Material	mouth-blown lead-free crystal with in Moon clear, Venus pink, Polaris white, Neptune blue, Mercury black and Pluto green
Mounting Materials	brushed stainless steel with titan coating / polished stainless steel / polished stainless steel with nitride titan coating / stainless steel with black powder coating
Mounting Colors	black / gold
Protection	IP 20
Nominal voltage	220-230V / A.C. 50 hz (EU) 100-120 V / A.C. 60 Hz (USA)
Class	II. EU / I. USA

## LIGHT SOURCE

Type	G80, 6W LED, 510 lm
Base	E27 EU / E26 USA
Voltage	200-240V, AC / 100-140V, AC
Temperature	2700 K
Color index	RA 90+
Dimming	Dimmable with TRIAC ; on demand dimmable with DALI, RF/WIFI, for information on dimming with other systems please contact your Bomma partner. Dimmer within the power cable.

## PACKAGING

Material	Cardboard
Size	510 × 430 × 430 mm 20,1 × 16,9 × 16,9 inch 1550 × 540 × 540 mm 61 × 21,3 × 21,3 inch

BMRC Group s.r.o.  
Hvězdova 1716/2b,  
Prague 4, 140 00,  
Czech Republic

[info@bomma.cz](mailto:info@bomma.cz)

step beyond